

# Modular LED Football Scoreboards

## Installation Manual

DD2363266

Rev 2 – 5 December 2013

# DAKTRONICS

Model Series	
FB-2500	FB-2600



**DD2363266**  
**Product 1647**  
**Rev 2 – 5 December 2013**

## **DAKTRONICS, INC.**

**Copyright © 2012-2013**

All rights reserved. While every precaution has been taken in the preparation of this manual, the publisher assumes no responsibility for errors or omissions. No part of this book covered by the copyrights hereon may be reproduced or copied in any form or by any means – graphic, electronic, or mechanical, including photocopying, taping, or information storage and retrieval systems – without written permission of the publisher.

*All Sport® and PanaView® are trademarks of Daktronics, Inc. Other trademarks used in this manual are the property of their respective owners.*



# Table of Contents

---

<b>Section 1:</b>	<b>Introduction .....</b>	<b>1</b>
1.1	Scoreboard Controllers.....	1
	Sport Codes.....	1
1.2	Troubleshooting .....	2
1.3	Specifications Label.....	2
1.4	Resources.....	2
1.5	Product Safety Approval.....	2
<b>Section 2:</b>	<b>Mechanical Installation .....</b>	<b>3</b>
2.1	Lifting the Scoreboard .....	3
2.2	Scoreboard Mounting.....	4
	I-Beam Clamps .....	5
	Clamping Angles .....	6
	Mounting Tubes .....	6
2.3	Ad Panel Mounting.....	7
	Unistrut Attachment.....	7
	I-Beam Clamps .....	8
	Clamping Angles .....	9
2.4	Scoreboard Protective Devices .....	9
<b>Section 3:</b>	<b>Electrical Installation .....</b>	<b>11</b>
3.1	Power .....	11
	Grounding.....	11
	Connection.....	12
3.2	Power-On Self-Test (POST) .....	13
	Radio Settings.....	13
3.3	Signal Connection .....	13
	Fiber Optic .....	14
3.4	Power/Signal Connections Between Sections.....	14
3.5	Lightning Protection .....	16
<b>Section 4:</b>	<b>Daktronics Exchange and Repair &amp; Return Programs .....</b>	<b>17</b>
4.1	Exchange Program .....	17
	Before Contacting Daktronics.....	17
4.2	Repair & Return Program .....	18
	Shipping Address .....	18
4.3	Daktronics Warranty and Limitation of Liability .....	18
<b>Section 5:</b>	<b>Scoreboard Options .....</b>	<b>19</b>
5.1	Team Name Message Centers (TNMCs).....	19
5.2	Trumpet Horns.....	19
5.3	Radio Control.....	19
5.4	Changeable Caption Kits.....	20
<b>Appendix A:</b>	<b>Specifications.....</b>	<b>21</b>
<b>Appendix B:</b>	<b>Reference Drawings .....</b>	<b>23</b>
<b>Appendix C:</b>	<b>Daktronics Warranty and Limitation of Liability.....</b>	<b>25</b>



# Section 1: Introduction

---

This manual explains the installation of Daktronics Modular LED Football Scoreboards (Product 1647). For additional information regarding the safety, installation, operation, or service of this system, refer to the telephone numbers listed in **Section 5**. This manual is not specific to a particular installation.

## **IMPORTANT SAFEGUARDS:**

- Please read and understand all instructions before beginning the installation process.
- Do not drop control equipment or allow it to get wet.
- Do not disassemble control equipment or electronic controls of the display; failure to follow this safeguard will make the warranty null and void.
- Disconnect display power when not in use or when servicing.
- Disconnect display power before servicing power supplies to avoid electrical shock. Power supplies run on high voltage and may cause physical injury if touched while powered.
- Do not modify the scoreboard structure or attach any panels or coverings to the scoreboard without the express written consent of Daktronics, Inc.

Project-specific information takes precedence over any other general information found in this manual. Such information may include:

- **Shop Drawings** – describe mounting methods and locations of display components and structural elements
- **System Risers** – describe power and signal connections between display components and the control location; may also include control room layout and schematic

Ensure all applicable material has been gathered before beginning the installation. Contact a Daktronics sales coordinator or project manager.

## 1.1 Scoreboard Controllers

Daktronics outdoor scoreboards are designed for use with the All Sport® 5000 series control consoles. This console uses keyboard overlays (sport inserts) to control numerous sports and scoreboard models. Refer to the following manual for operating instructions:

- **All Sport 5000 Series Control Console Operation Manual (ED-11976)**

The scoreboard controller manual is available online at [www.daktronics.com/manuals](http://www.daktronics.com/manuals).

### **Sport Codes**

At right is a table of common sport codes for the multiple modes of the football scoreboards in this manual. Refer to the Operation Manuals for a complete listing of sport codes.

Sport	Common Code(s)
	<i>All Sport 5000</i>
Baseball	5601 (with clock) 5602 (without clock)
Football	6601
Lacrosse/ Field Hockey	4601
Soccer	7601
Track	8601 (manual timing)

## 1.2 Troubleshooting

For an extensive troubleshooting guide and instructions on how to replace scoreboard components, refer to the following manual:

- **Outdoor LED Scoreboards Service Manual (DD2124597)**

The service manual is available online at [www.daktronics.com/manuals](http://www.daktronics.com/manuals).

## 1.3 Specifications Label

Power specifications as well as serial and model number information can be found on an ID label on the display, similar to the one shown in **Figure 1**.

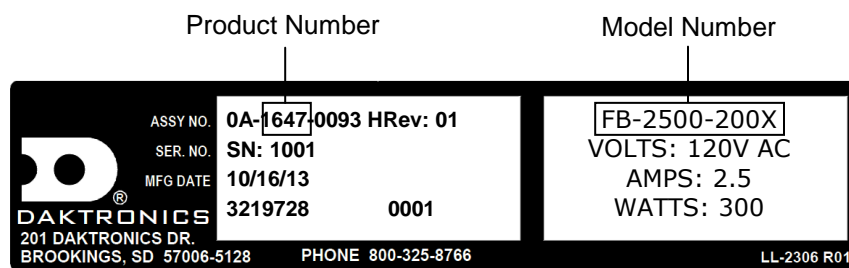

**Figure 1:** Specifications Label

Please have the assembly number, model number, and the date manufactured on hand when calling Daktronics customer service to ensure the request is serviced as quickly as possible. Knowing the facility name and/or job number will also be helpful. Note that the Product Number(s) are sometimes used to distinguish different generations of the scoreboards having the same model number.

## 1.4 Resources

**Figure 2** illustrates a Daktronics drawing label. The drawing number is located in the lower-right corner of a drawing. This manual refers to drawings by listing the last set of digits and the letter preceding them. In the example, the drawing would be referred to as **Drawing C-325405**.

THE CONCEPTS EXPRESSED AND DETAILS SHOWN IN THIS DRAWING ARE CONFIDENTIAL AND PROPRIETARY. DO NOT REPRODUCE BY ANY MEANS, INCLUDING ELECTRONICALLY, WITHOUT THE EXPRESSED WRITTEN CONSENT OF DAKTRONICS, INC. COPYRIGHT 2008 DAKTRONICS, INC.			
DAKTRONICS, INC. BROOKINGS, SD 57006			
PROJ: DAKTRONICS UNIVERSITY			
TITLE: SYSTEM RISER DIAGRAM			
DES. BY: AORMESH		DRAWN BY: AORMESH	DATE: 15 JAN 08
REVISION	APPR BY:	14963-R01	
00	SCALE: NONE	C-325405	

Drawing Number

**Figure 2:** Daktronics Drawing Label

Daktronics identifies manuals by the DD or ED number located on the cover page of each manual. For example, this manual would be referred to as **DD2363266**.

## 1.5 Product Safety Approval

Daktronics outdoor scoreboards are ETL listed and tested to CSA standard for outdoor use. Contact Daktronics with any questions regarding testing procedures.



## Section 2: Mechanical Installation

Mechanical installation consists of installing concrete footing and steel beams and mounting the scoreboard and accompanying ad panels to the beams. Refer to site-specific diagrams for proper placement and mounting method of display pieces. These drawings may be requested from a Daktronics sales coordinator or project manager.

Be sure that the installation complies with local building codes and is suitable for the particular soil and wind conditions. The columns, footings, and all connection details must be designed and certified by a professional engineer licensed to practice in the state of the scoreboard installation.

**Note:** Daktronics does not assume any liability for any installation derived from the information provided in this manual or installations designed and installed by others.

### 2.1 Lifting the Scoreboard

Larger scoreboard sections and message centers are shipped equipped with eyebolts used to lift them. The eyebolts are located along the top of the cabinet for each scoreboard or scoreboard section. Daktronics scoreboards use  $1/2$ " and  $5/8$ " shoulder-type eyebolts mounted to the top of each scoreboard section.

**Daktronics strongly recommends using a spreader bar, or lifting bar, to lift the display.** Spreader bars ensure the force on the eyebolts remains straight up, minimizing lifting stress.

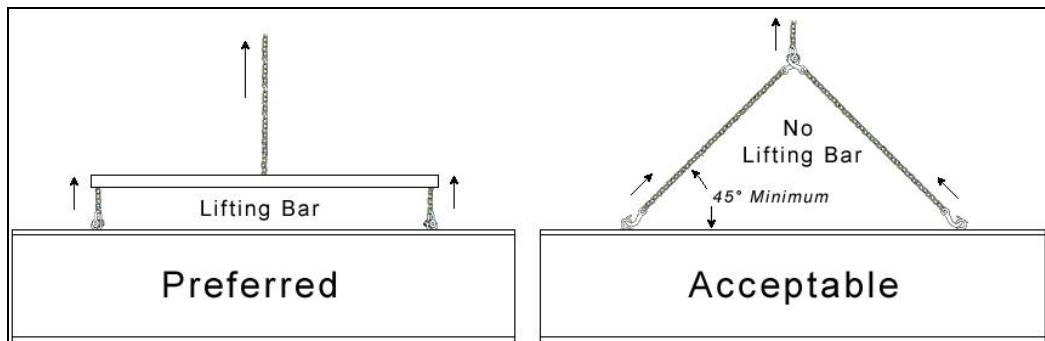

**Figure 3:** Lifting Methods

**Figure 3** illustrates the preferred scoreboard lifting method on the left and an acceptable alternative lifting method on the right. When lifting the display:

- Use a spreader bar if possible.
- Use every lifting point provided.

Cables and chains attached to the eyebolts and directly to a center lifting point, as shown in the right-hand example in **Figure 3**, can create a dangerous lateral force on the eyebolts and may cause the eyebolts to fail. The smaller the angle between the cable and the top of the display, the lighter the sign must be to safely lift it. If this method must be used, ensure a minimum angle between the chain and scoreboard of at least 45°.

Do NOT attempt to lift the display if the angle is less than 45°. Exceeding load angles or weight limits could cause the bolts in the scoreboard cabinet to buckle, resulting in serious damage to the scoreboard or injury to personnel. Also, loads should be applied directly in the plane of the eyebolt as shown in **Figure 4**.

**Note:** Daktronics assumes no liability for damages resulting from incorrect setup or lifting methods. Eyebolts are intended for lifting only. Do not attempt to permanently support the display by the eyebolts.

In typical multi-section installations, the lower scoreboard is installed first and secured to the support beams. The upper section is then placed atop or above the lower section and attached to the beams. Refer to **Section 3.4** for more information on the power/signal connections between sections.

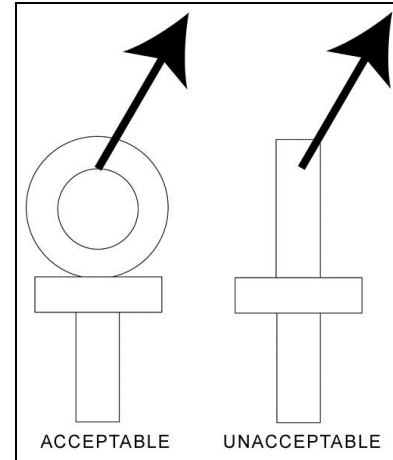

**Figure 4:** Eyebolt Plane Load

If installers remove the eyebolts, plug the holes with bolts and the rubber washers that are used with the eyebolts. Apply silicone or another waterproof sealant to the eyebolt openings. Also inspect the top and sides of the display for any other holes or openings that may allow moisture to enter the display and plug and seal those openings.

## 2.2 Scoreboard Mounting

Three standard mounting methods are available for Daktronics modular football scoreboards. Each method requires spring nuts to be inserted into the rear channel of the scoreboard:

1. Insert spring nuts into the top and bottom scoreboard channels. Twist the spring nuts until they are perpendicular to the scoreboard channel (**Figure 5**).

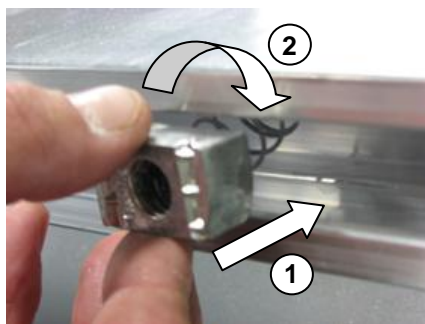

**1) Insert into channel    2) Twist**



**Correct spring nut position**

**Figure 5:** Spring Nut Insertion

**Note:** Each scoreboard section require four spring nuts per beam (two at the top and two at the bottom).

2. Measure the beam spacing and position a spring nut on either side of the beams.

Once the spring nuts are in place, refer to the appropriate section below for the type of mounting hardware provided with the scoreboard.

## I-Beam Clamps

This mounting method is used to mount a scoreboard to I-beams with a flange thickness of  $\frac{1}{4}$ " -  $\frac{3}{4}$ ". If flange thickness is greater than  $\frac{3}{4}$ ", longer bolts will be required at additional expense.

Mounting hardware includes I-beam clamps,  $\frac{1}{2}$ -13 x 3" bolts,  $\frac{1}{2}$ " flat washers, and  $\frac{1}{2}$ " lock washers. Refer to **Figure 6** and **Drawing A-1052565** in **Appendix B**.

1. Position a scoreboard section at the front of the beams, and lift it to the desired height.
2. Slide a lock washer, flat washer, and I-beam clamp onto the bolt, and loosely screw the bolt into the spring nut.
3. Position each I-beam clamp assembly as close to the I-beam flanges as possible.
4. Make final adjustments in the positioning of the scoreboard section to ensure it is flush and level, and firmly tighten all of the bolts.
5. Repeat steps 1-4 with all scoreboard sections.

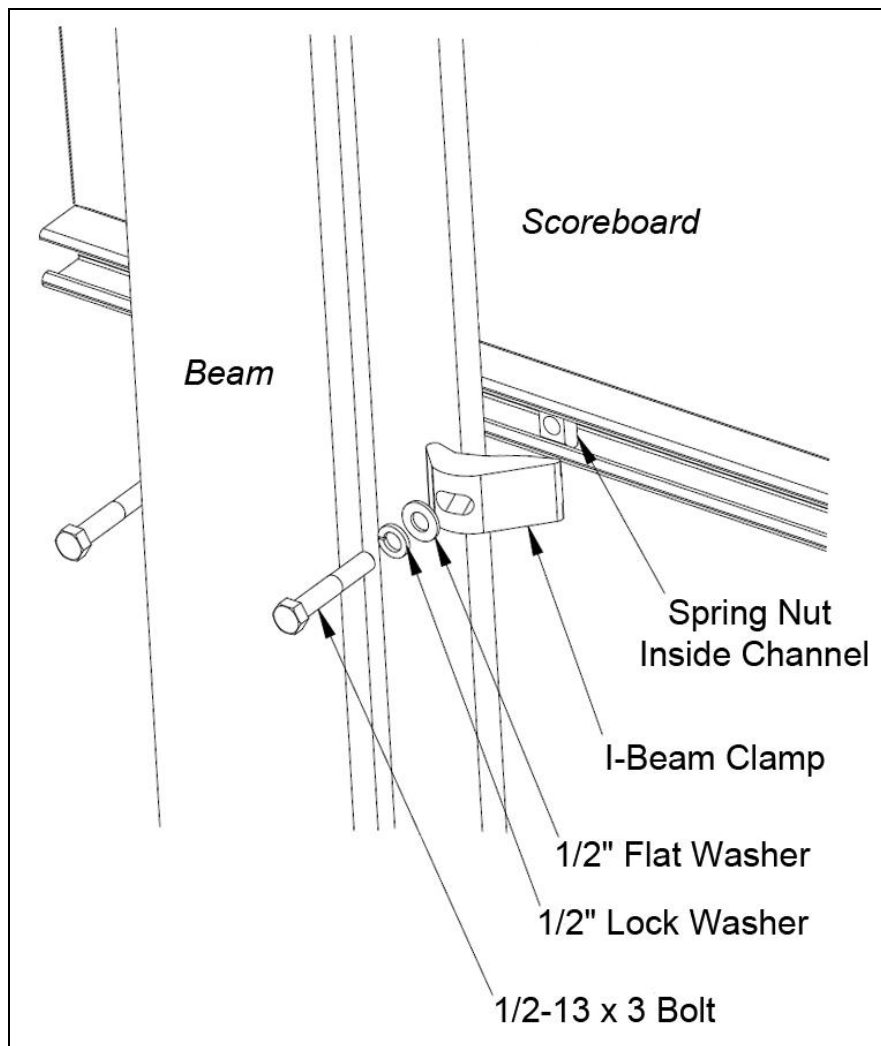

**Figure 6:** I-beam Clamp Mounting Method, Rear Isometric View

## Clamping Angles

This mounting method may be used to mount a scoreboard to I-beams or any beam/pole that does not have flanges.

Mounting hardware includes rear clamping angles; 1/2-13 x 24" threaded rods; and 1/2" nuts, flat washers, and lock washers. Refer to **Figure 7** and **Drawing A-1048184** in **Appendix B**.

**Note:** The threaded rods do not pass through the beams; they run along both sides.

1. Screw a threaded rod into each of the spring nuts as far as it will go.
2. Position a scoreboard section at the front of the beams with the threaded rods extending from the rear of the spring nuts, straddling the beams.
3. Lift the scoreboard section to the desired height.
4. Slide clamping angles over the ends of the rods and loosely install the washers and nuts.
5. Make final adjustments in the positioning of the scoreboard section to ensure it is flush and level, and firmly tighten all of the 1/2" hex nuts.
6. Repeat steps 1-5 for all scoreboard sections.

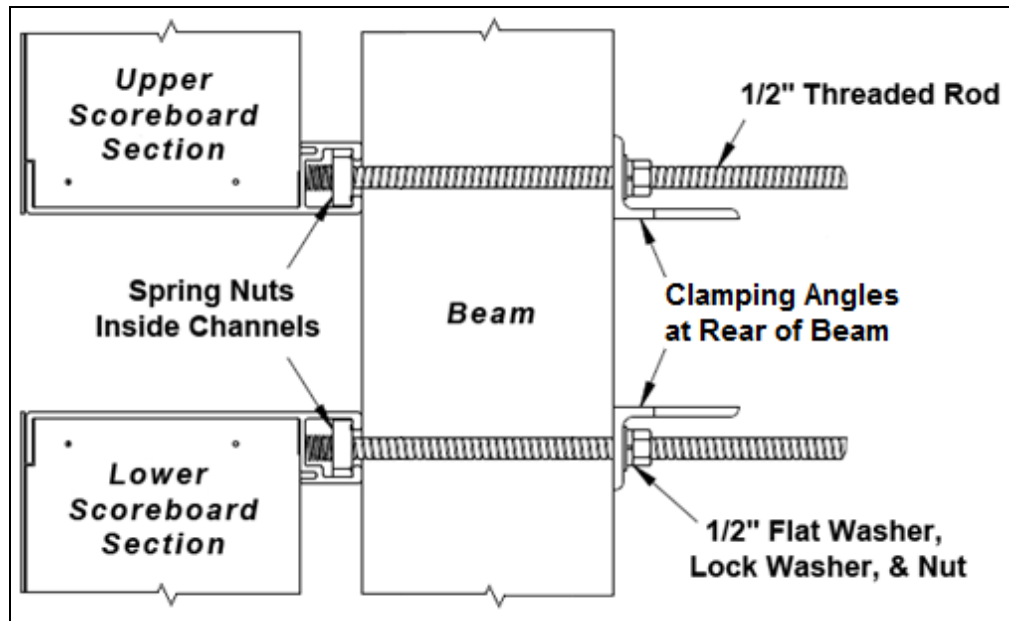

**Figure 7:** Clamping Angle Mounting Method, Side View

## Mounting Tubes

This mounting method may be used to mount a scoreboard to horizontal beams. The mounting tubes are attached to the scoreboard using spring nuts and 1/2" hardware as described above; this may be done during manufacturing or on-site. Refer to **Figure 8** and **Drawing A-1048268** in **Appendix B** for mounting tube assembly. The clip angles can be adjusted vertically before they are bolted or welded to the horizontal beams. Recommended attachment method and positioning of display pieces are provided in site-specific diagrams.

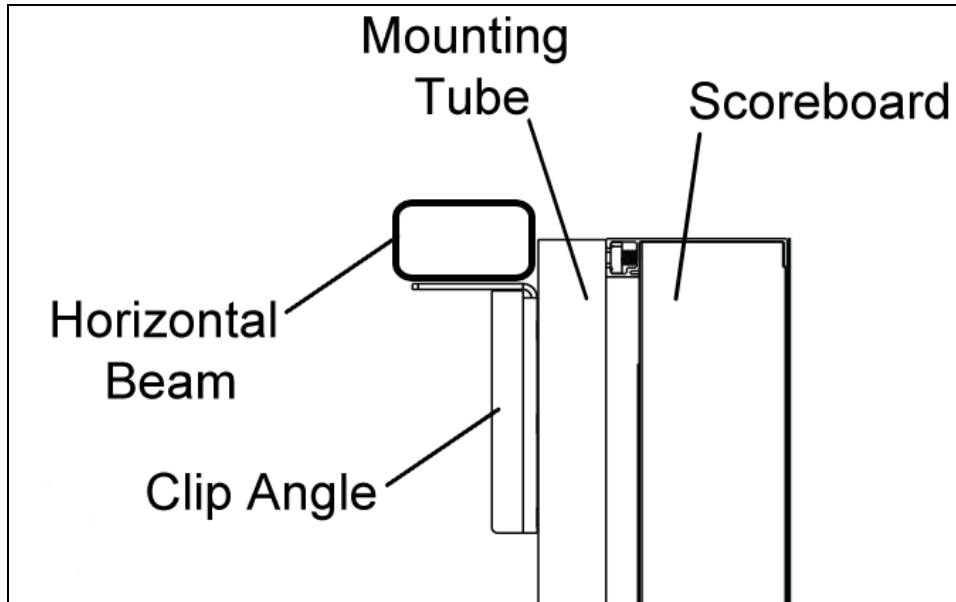

Figure 8: Mounting Tube Attachment, Side View

## 2.3 Ad Panel Mounting

### Unistrut Attachment

1. Using the backup channel as a template, drill four  $\frac{7}{16}$ " holes in the upper and lower rear flanges of the ad panel where the beams will be located.

**Note:** Try to ensure that the two center holes will be within the width of the beam.

2. If the ad panel has backsheets, remove them as needed to access the ad panel interior.
3. Attach the piece of unistrut to the ad panel with the included hardware, as shown in **Figure 9**.
4. If any backsheets were removed, put them back on at this time.
5. Place spring nuts into the unistrut. Twist the spring nuts until they are perpendicular to the unistrut channel (refer to **Figure 5** from **Section 2.2**).

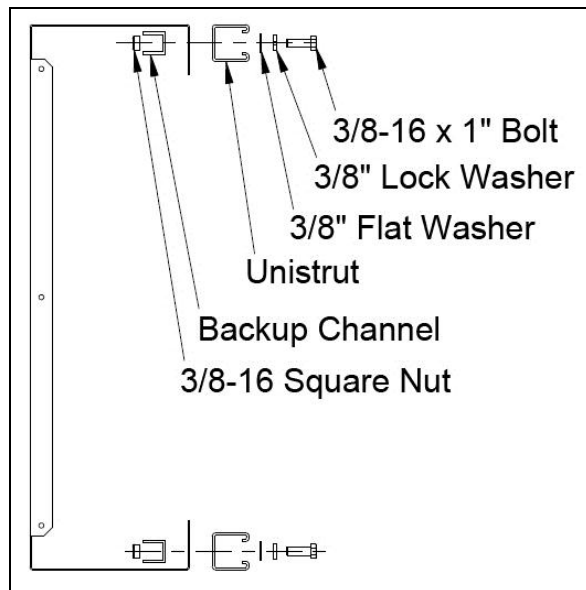

Figure 9: Unistrut Attachment, Side View

Once the unistrut is attached and the spring nuts are in place, refer to the appropriate section below for the type of mounting hardware provided with the ad panel.

## I-Beam Clamps

Mounting hardware includes I-beam clamps,  $1/2$ -13 x 3" bolts,  $1/2$ " flat washers, and  $1/2$ " lock washers. Refer to **Figure 10** and **Drawing A-1052539** in **Appendix B**.

**Note:** I-beams must have a flange thickness of  $1/4$ " -  $3/4$ ". If flange thickness is greater than  $3/4$ ", longer bolts will be required at added expense.

1. Position the ad panel at the front of the beams, and lift it to the desired height.
2. Slide a lock washer, flat washer, and I-beam clamp onto the bolt, and loosely screw the bolt into the spring nut.
3. Position each I-beam clamp assembly as close to the I-beam flanges as possible.
4. Make final adjustments in the positioning of the ad panel to ensure it is flush and level, and firmly tighten all of the bolts.

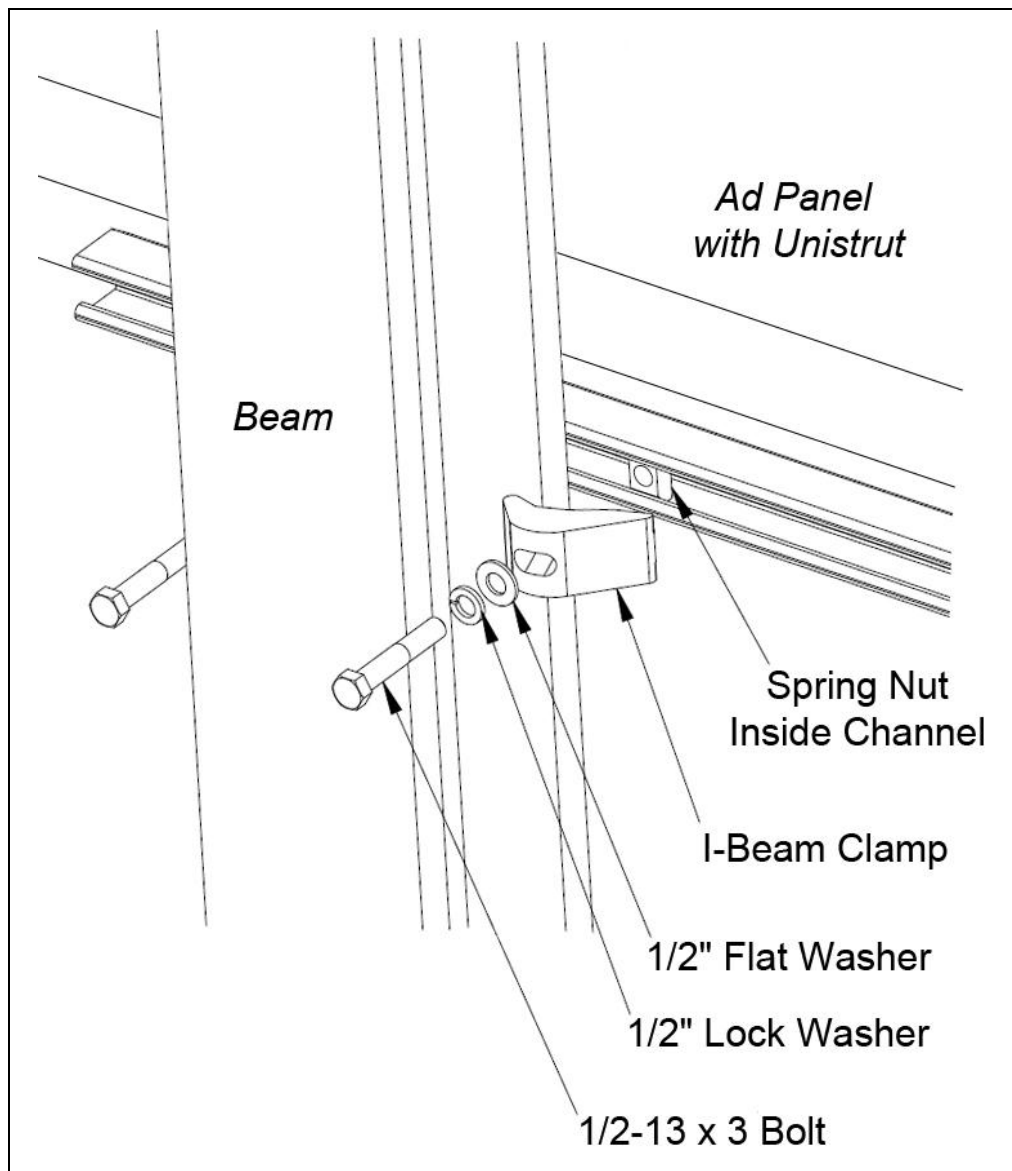

**Figure 10:** Ad Panel Mounting with I-beam Clamps, Rear Isometric View

## Clamping Angles

Mounting hardware includes rear clamping angles; 1/2-13 x 24" threaded rods; and 1/2" nuts, flat washers, and lock washers. Refer to **Figure 11** and **Drawing A-1052388** in **Appendix B**.

**Note:** The threaded rods do not pass through the beams; they run along both sides.

1. Screw a threaded rod into each of the spring nuts as far as it will go.
2. Position the scoreboard at the front of the beams, and lift it to the desired height.
3. Slide clamping angles over the ends of the rods and loosely install the washers and nuts.
4. Make final adjustments in the positioning of the ad panel to ensure it is flush and level, and firmly tighten all of the 1/2" hex nuts.

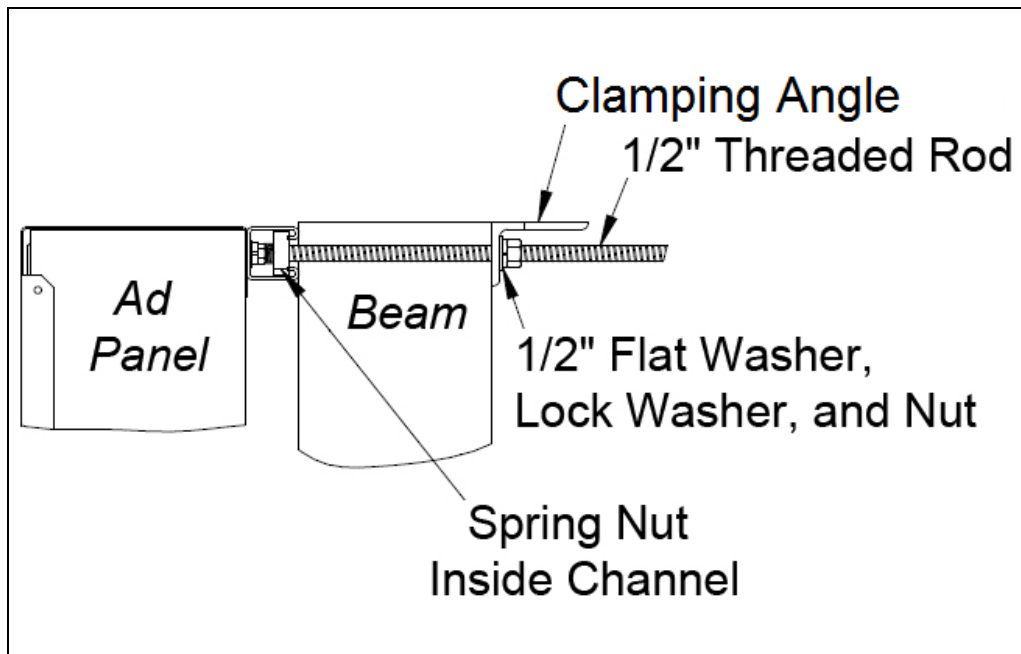

**Figure 11:** Ad Panel Mounting with Clamping Angles, Side View

## 2.4 Scoreboard Protective Devices

Daktronics makes optional protective devices, including screens and netting, to help prevent damage to the scoreboard due to normal ball impacts.

**Note:** Some users install devices to protect the scoreboard from projectiles. Scoreboard protection devices not provided by Daktronics must be approved by Daktronics prior to installation. Failure to follow this approval procedure will void the scoreboard warranty.





## Section 3: Electrical Installation

---

**CAUTION:** Only qualified individuals should terminate power and signal cable and access the electrical components of the display and its associated equipment. It is the responsibility of the electrical contractor to ensure that all electrical work meets or exceeds local and national codes.

Daktronics engineering staff must approve all changes or the warranty will be void.

### 3.1 Power

Correct power installation is imperative for proper display operation. The subsections that follow give details of display power installation. Only qualified individuals should attempt to complete the electrical installation; untrained personnel should not attempt to install these displays or any of the electrical components. Improper installation could result in serious damage to the equipment or injury to personnel.

Multi-section outdoor scoreboards require a dedicated 120 V (or 240 V for international use) circuit for incoming power (refer to **Appendix A**). The display itself has no breakers or fuses.

**WARNING:** It is critical that 120 V scoreboard circuits be fused at 20 A and that all conductors used must be designed to pass a 20 A current in normal operation. For 240 V scoreboards, consult local electrical codes. Failure to meet wiring and overcurrent protection device requirements will void the scoreboard warranty.

#### Grounding

The display must be properly grounded according to local and national codes or the warranty will be void. Proper grounding is necessary for reliable equipment operation and protects the equipment from damaging destructive disturbances and lightning.

Daktronics recommends a resistance-to-ground of 10 ohms or less. The electrical contractor performing the electrical installation can verify ground resistance. Daktronics Sales and Service personnel can also provide this service.

The display system must be earth-ground. The material for an earth-ground electrode differs from region to region and may vary according to conditions present at the site. Consult local and national electrical codes.

Daktronics does not recommend using the support structure as an earth-ground electrode; concrete, primer, corrosion, and other factors make the support structure a poor ground.

**Note:** The support structure may be used as an earth-ground electrode only if designed to do so. A qualified inspector must approve the support structure and grounding methods.

There are two types of power installation: installation with ground and neutral conductors provided, and installation with only a neutral conductor provided. These two power installations differ slightly, as described in the following paragraphs:

### *Installation with Ground and Neutral Conductors Provided*

For this type of installation, the power circuit must contain an isolated earth-ground conductor. In this circumstance, do not connect neutral to ground at the disconnect or at the display as this would violate electrical codes and void the warranty.

Use a disconnect so that all ungrounded lines can be disconnected. The National Electrical Code requires the use of a lockable power disconnect within sight of or at the display.

### *Installation with Only a Neutral Conductor Provided*

Installations where no grounding conductor is provided must comply with Article 250-32 of the National Electrical Code. If the installation in question meets all of the requirements of Article 250-32, the following guidelines must be observed:

- Connect the grounding electrode cable at the local disconnect, never at the display driver/power enclosure.
- Use a disconnect that opens all of the ungrounded phase conductors.

## Connection

Both power and signal cables are routed into the scoreboard from the rear via conduit. All power and signal wiring terminates at the master driver enclosure.

Look for a warning label similar to **Figure 12** to locate the access panel to the driver enclosure. Remove the screws or loosen the latches to open the access door panel. Remove the metal cover of the driver enclosure to expose the driver components (**Figure 13**).



**Figure 12:** Power Warning Label

Connect the appropriate wires coming through the rear of the scoreboard to the main terminal block, as shown in **Figure 13**. Note that SIGNAL OUT connects here as well.

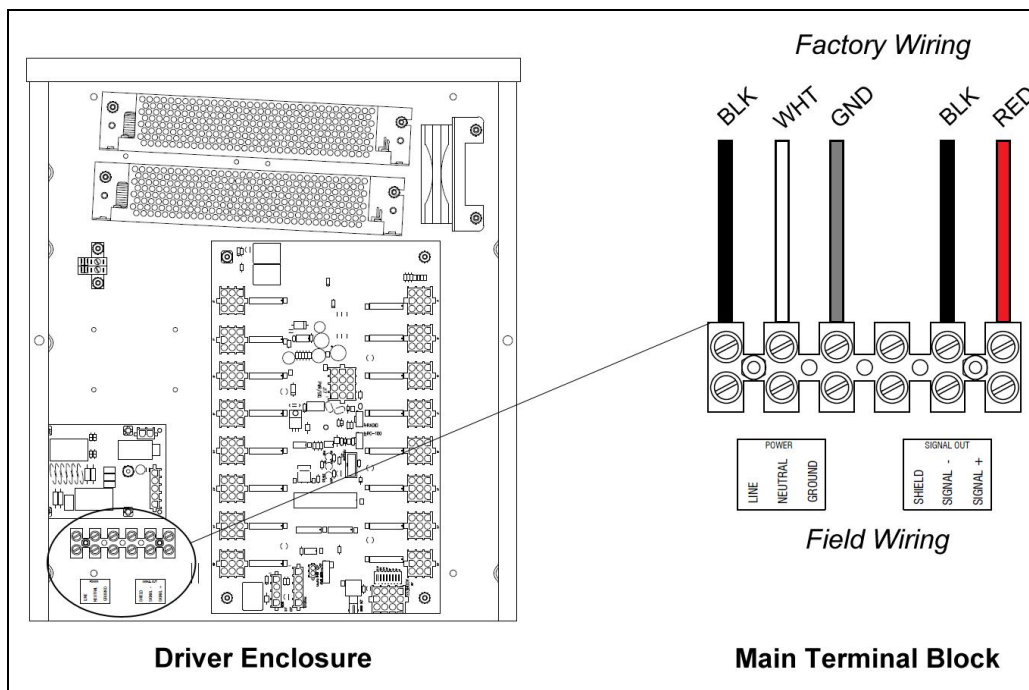

**Figure 13:** Driver Enclosure & Main Terminal Block

Certain scoreboard sections do not receive power via terminal block. Instead, an interconnect harness routes from the nearest scoreboard section. Refer to **Section 3.4**.

**Note:** If a power receptacle is needed to operate the control console at the scoreboard for troubleshooting, Daktronics recommends that an installation electrician provides a 120 V outlet close to the disconnect box specifically for this purpose.

### 3.2 Power-On Self-Test (POST)

The scoreboard performs a self-test each time that power is turned on and the control console is powered off or not attached to the scoreboard. If the control console is attached and powered on, the self-test does not run, and data from the control console is displayed on the scoreboard after a brief period of time. Each scoreboard self-test pattern will vary depending on the scoreboard model, the number of drivers and types of digits. **Figure 14** shows an example of the LED bar test pattern that each digit performs.

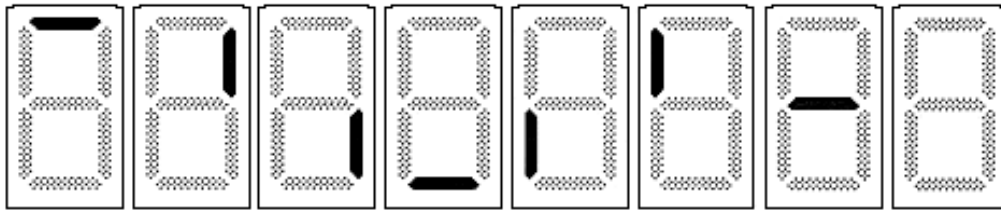

**Figure 14:** Digit Segment POST

### Radio Settings

If a radio receiver is installed, the radio Broadcast settings (“b1”) and Channel settings (“C1”) will be displayed in the clock digits during the POST. These values must match the settings in the control console (refer to the manual listed in **Section 1.1**).

### 3.3 Signal Connection

For wired setups, route signal cable from the control location into the conduit knockout on the rear of the scoreboard to the signal surge arrestor card (**Figure 15**), located just above the main termination block in the driver enclosure.

At the SIGNAL IN terminal block, connect red signal wire to positive (+) and black signal wire to negative (-).

**Note:** Be sure to properly connect the shield (silver) wire to the SHIELD terminal.

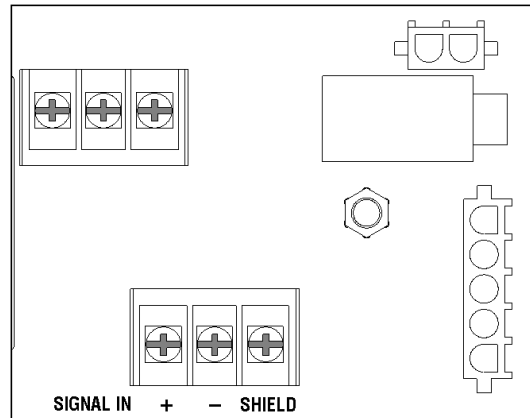

**Figure 15:** Signal Surge Arrestor Card

To connect signal to additional scoreboard sections, route signal wire from SIGNAL OUT on the main terminal block (**Figure 13**) of one section to SIGNAL IN on the signal card of another.

For signal cable, Daktronics recommends, as a minimum, single-pair, shielded cable, 22 AWG (part # W-1077). Two-pair shielded cable (part # W-1234) is preferred.

## Fiber Optic

Another common signal communication method is fiber optic cabling. A minimum cabling of multi-mode, 62.5/125 um, and 2-core fiber cable is recommended (part # W-1242). The fiber optic cable is terminated to a male ST-type connector and plugged into the mating J26 FIBER jack on the driver (**Figure 16**). This method requires a signal converter between the All Sport console's scoreboard output and the fiber optic cable (not provided by Daktronics).

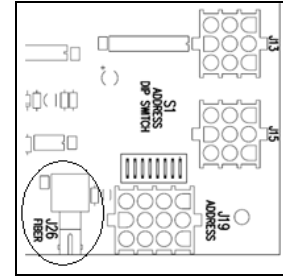

**Figure 16:** Driver Fiber Connection Location

## 3.4 Power/Signal Connections Between Sections

The table below lists the scoreboard sections that do not receive main power or signal:

Information Shown	Model #	Driver/Power Supply Location	Power/Signal Connections*
T.O.L. (HOME)	FB-2531, FB-2533, FB-2536, FB-2538, FB-2540, FB-2545	HOME Score	A1 J1 PS1 J1 A1 J50
T.O.L. (GUEST)	FB-2571, FB-2573, FB-2575, FB-2577, FB-2579, FB-2583	GUEST Score	A1 J10 PS1 J10 A1 J50
DOWN	FB-2618, FB-2628, FB-2658	TO GO	A1 J3 PS1 J3 A1 J42B Mod 1 J2
QTR (quarter)	FB-2621, FB-2631, FB-2661	BALL ON	A1 J8 PS1 J8 A1 J42B Mod 4 J1

\* For HOME T.O.L. sections built prior to September 2013, the digit connects to J14 on A1/PS1. For GUEST T.O.L. sections, the digit connects to J15 on A1/PS1. Backlit/electronic captions for either section connect to J42B.

### The T.O.L., DOWN, and QTR sections may have up to four connections:

- Route the 9-pin plug into the adjacent section and connect to the appropriate jack on the primary (A1) driver.
- Route the 2-pin plug into the adjacent section and connect to the appropriate jack on the Power Supply (**24" + white LED digits or 36" + red/amber LED digits only**).
- If the section includes a backlit or electronic caption, a 5-pin plug must be connected to the power/signal interconnect cable coming from the primary (A1) driver.
- A ribbon cable must be connected between the last mod of the DOWN and BALL ON electronic captions to the first mod of the TO GO and QTR electronic captions.

Refer to **Figure 17** for internal power/signal connection guidelines between a T.O.L. section and its mating HOME/GUEST section.

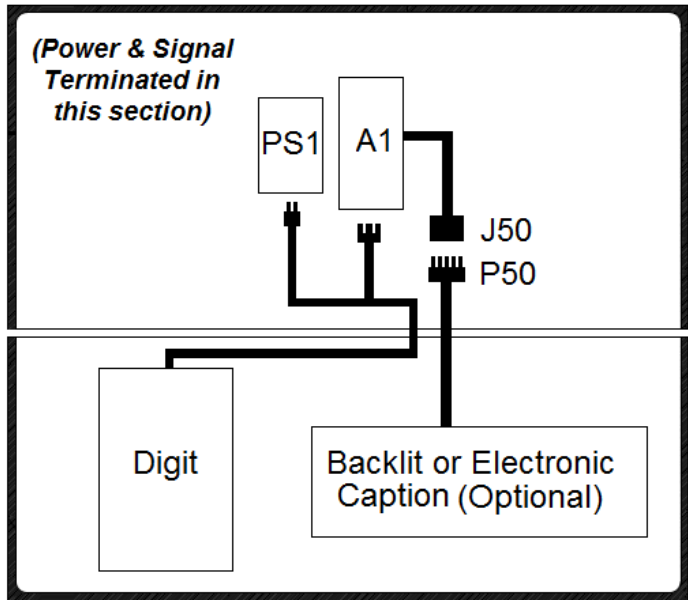

**Figure 17:** T.O.L. Power/Signal Interconnections (Front View)

Refer to **Figure 18** for internal power/signal connection guidelines between DOWN/TO GO and BALL ON/QTR sections.

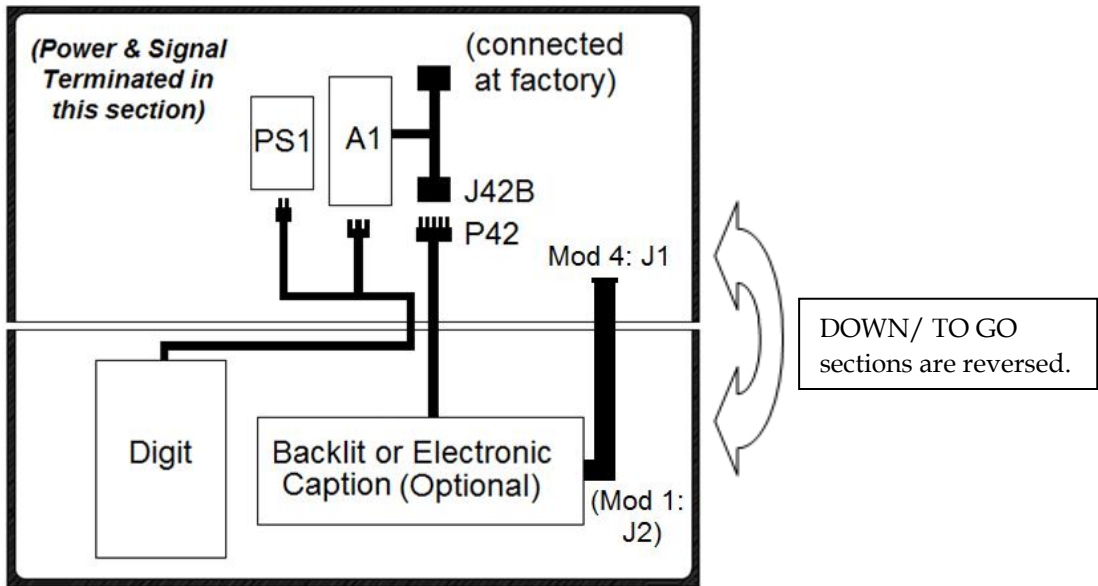

**Figure 18:** BALL ON/QTR Power/Signal Interconnections (Front View)

For sections that are too far apart to use internal interconnects, the signal may be re-driven, or “daisy-chained”. Typically, the Game Clock section would receive primary signal from the control location, and signal cable could then branch out to the HOME score and GUEST score sections. From there, signal can be re-driven once more to the DOWN/TO GO and BALL ON/QTR sections. Refer to **Figure 19** for an example of re-driving signal.

**Note:** For radio-controlled systems, the radio receiver may be located in one section, while signal cable is routed to the other sections as needed.

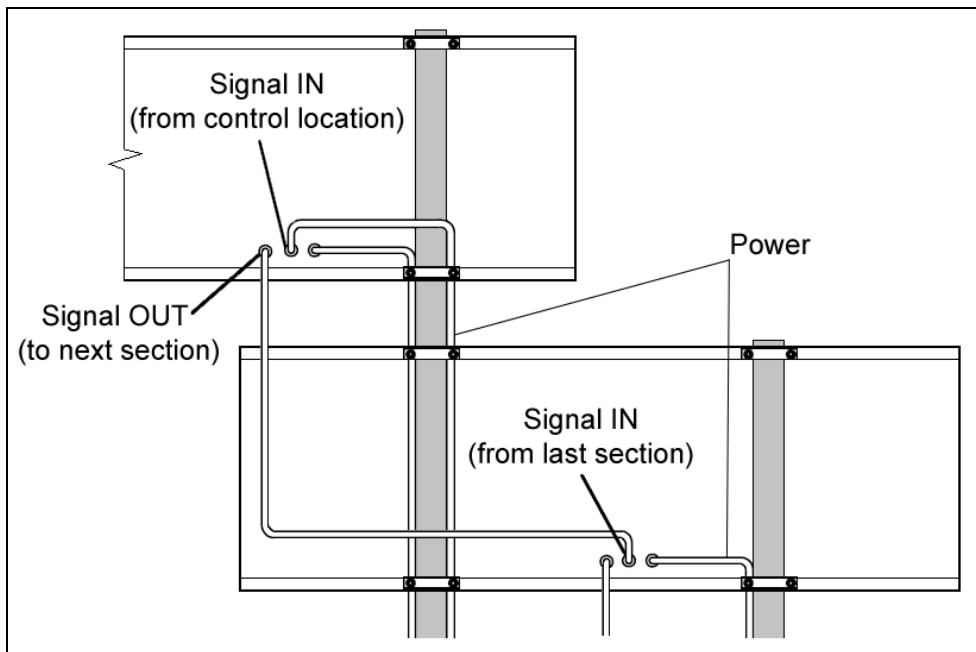

**Figure 19:** Re-driving Signal (Rear View)

### 3.5 Lightning Protection

The use of a disconnect near the scoreboard to completely cut all current-carrying lines significantly protects the circuits against lightning damage. In order for this system to provide protection, the power must be disconnected when the scoreboard is not in use.

The control console should also be disconnected from power and from the signal junction box when the system is not in use. The same surges that may damage the scoreboard’s driver can also damage the console’s circuitry.

# Section 4: Daktronics Exchange and Repair & Return Programs

---

## 4.1 Exchange Program

The Daktronics Exchange Program is a service for quickly replacing key components in need of repair. If a component fails, Daktronics sends a replacement part to the customer who, in turn, returns the failed component to Daktronics. This decreases equipment downtime. Customers who follow the program guidelines explained below will receive this service.

### Before Contacting Daktronics

Identify these important numbers:

Display Serial Number: \_\_\_\_\_  
Display Model Number: \_\_\_\_\_  
Job/Contract Number: \_\_\_\_\_  
Date Installed: \_\_\_\_\_  
Daktronics Customer ID Number: \_\_\_\_\_

To participate in the Exchange Program, follow these steps:

**1. Call Daktronics Customer Service.**

Market Description	Customer Service Number
Schools (including community/junior colleges), religious organizations, municipal clubs and community centers	877-605-1115
Universities and professional sporting events, live events for auditoriums and arenas	866-343-6018

**2. When the exchange part is received, mail the old part to Daktronics.**

If the replacement part fixes the problem, send in the problem part being replaced.

- a. Package the old part in the same shipping materials in which the replacement part arrived.
- b. Fill out and attach the enclosed UPS shipping document.
- c. Ship the part to Daktronics.

**3. The defective or unused parts must be returned to Daktronics within 5 weeks of initial order shipment.**

If any part is not returned within five (5) weeks, a non-refundable invoice will be presented to the customer for the costs of replenishing the exchange parts inventory with a new part.

Daktronics reserves the right to refuse parts that have been damaged due to acts of nature or causes other than normal wear and tear.

## 4.2 Repair & Return Program

For items not subject to exchange, Daktronics offers a Repair & Return Program. To send a part for repair, follow these steps:

- 1. Call or fax Daktronics Customer Service:**  
Refer to the appropriate market phone number in the chart on the previous page.  
**Fax:** 605-697-4444
- 2. Receive a case number before shipping.**  
This expedites repair of the part.
- 3. Package and pad the item carefully to prevent damage during shipment.**  
Electronic components, such as printed circuit boards, should be placed in an antistatic bag before boxing. Daktronics does not recommend using packing 'peanuts' when shipping.
- 4. Enclose:**
  - name
  - address
  - phone number
  - the case number
  - a clear description of symptoms

### Shipping Address

Daktronics Customer Service  
[Case #]  
201 Daktronics Drive, Dock E  
Brookings, SD 57006

## 4.3 Daktronics Warranty and Limitation of Liability

The Daktronics Warranty and Limitation of Liability is located in **Appendix C**. The Warranty is independent of Extended Service agreements and is the authority in matters of service, repair, and display operation.



## Section 5: Scoreboard Options

---

### 5.1 Team Name Message Centers (TNMCs)

Team Name Message Centers (TNMCs) are programmable LED displays that allow users to show custom Home and Guest names. TNMCs are typically ordered factory-installed but can be field-mounted after the scoreboard is in place.

For more information about TNMCs, contact a Daktronics representative or refer to the service manual listed in **Section 1.2**.

### 5.2 Trumpet Horns

Trumpet horn options are available for installation only on scoreboards that have clocks. There are two types of optional trumpet horns:

- Internally mounted 120 V trumpet horn
- Externally mounted 12 VDC trumpet horn

A 120 V trumpet horn cannot be installed on a 240 V model scoreboard. For more information about trumpet horns, contact a Daktronics representative or refer to the **Trumpet Horn Installation Manual (ED-10006)**, available online at [www.daktronics.com/manuals](http://www.daktronics.com/manuals).

### 5.3 Radio Control

Radio control is an option for all Daktronics outdoor LED scoreboards. The system provides scoreboard control via a 2.4 GHz, extra-high frequency FM signal.

The radio transmitter and receiver are not standard. This setup requires a control console equipped with radio output as well as a radio receiver plugged into the primary driver and mounted internally to the front panel of the scoreboard.

For additional information about this option, contact a Daktronics representative; for complete information on setting up radio communication control, refer to the **Gen V Radio Installation Manual (ED-13831)** or the **Gen VI Radio Installation Manual (DD2362277)**, both available online at [www.daktronics.com/manuals](http://www.daktronics.com/manuals).

## 5.4 Changeable Caption Kits

Caption kits contain hardware for one caption only and consist of an upper caption retainer, a lower caption retainer, a changeable caption panel and screws.

The standard HOME and GUEST captions are applied directly to the face of the scoreboard. Team name captions are on changeable panels that fit into retainers mounted above and below the HOME and GUEST captions. If these retainers are not already present, attach the retainers included with the caption kit.

Other caption kits are available to show different information for different sports.

To install a changeable panel:

1. Insert the screws on the caption changing pole (Daktronics part # 0F-1091-0099) into the keyholes on the panel.
2. Lift the panel all the way up into the upper retainer and then insert the bottom of the panel into the lower retainer (**Figure 20**).
3. Take the screws on the caption changing pole out of the keyholes.

Reverse this procedure to remove the caption panel.

The caption changer pole is extendable. Loosen the ring tightener and extend the pole to the desired length, and then tighten the ring before lifting the caption.

**CAUTION:** The aluminum caption changer can conduct electricity. Do not use it within 20-feet of power lines. Also be careful when using the caption changer in high or gusting winds. Wind may catch the panel and unhook it from the changer or make it difficult to maintain a grip on the pole. Hold the pole tightly in windy conditions.

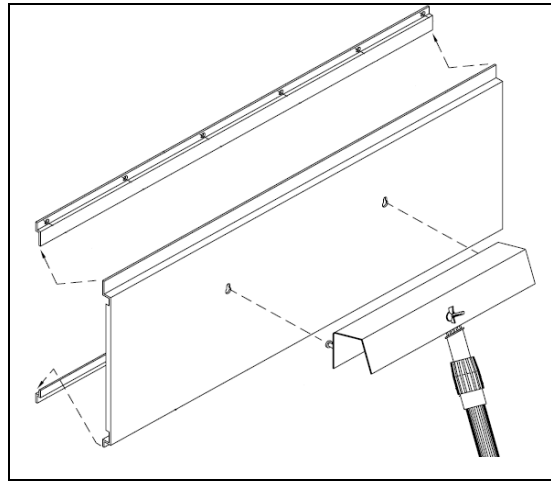

**Figure 20:** Changing Scoreboard Captions

# Appendix A: Specifications

---

<i>Document Title</i>	<i>Document Number</i>
FB-2500 & FB-2600 Series Modular Football Scoreboards Specifications .....	<b>DD2216211</b>



# MODULAR FB SCOREBOARDS PRODUCT SPECIFICATIONS



Designed to accompany Daktronics standard outdoor LED video displays, the FB-2500 and FB-2600 series of modular football scoreboards provides an endless variety of layout possibilities. They may also be used independently of a video display, such as for auxiliary scoreboards along a section of narrow fascia. Select from numerous clock, home score, guest score, and game information sections to complement the video display and create a unique scoring system.

These football scoreboards feature amber, red, or white LED digits to display period time to 99:59, HOME and GUEST scores to 99, T.O.L. (time outs left) to nine and DOWN/TO GO/BALL ON/QTR (quarter) information. Six-digit clocks can display race time to 99:59.99. An arrow- or diamond-shaped group of LEDs indicates possession. When period time is less than one minute, scoreboard displays time to 1/10 of a second. Scoreboards shown with optional striping, Team Name Message Centers (TNMCs), and amber PanaView® digits.

## DIGITS

- Digit sizes vary per model (see tables on following pages)
- Scoreboard features robust weather-sealed digits (see [DD2495646](#)).
- Digits may be dimmed for night viewing.

## DISPLAY COLOR

Choose from 150+ colors (from Martin Senour® paint book) at no additional cost.

## CONSTRUCTION

Alcoa aluminum alloy 5052 for excellent corrosion resistance

## PRODUCT SAFETY APPROVAL

ETL listed to UL 48, tested to CSA standards, and CE labeled

## OPERATING TEMPERATURES

- Display: -22° to 122° Fahrenheit (-30° to 50° Celsius)
- Console: 32° to 130° Fahrenheit (0° to 54° Celsius)

## CAPTIONS

- HOME and GUEST captions are available in three different sizes, depending on the model: 14" (356 mm), 15" (381 mm), and 18" (457 mm) high. All other captions are 12" (305 mm) high. Models FB-2610 & FB-2611 use 8" (203 mm) captions.
- Standard captions are vinyl. Track captions are on changeable panels. All other captions are applied directly to the display face.
- Optional backlit captions feature white letters on a black background for increased readability in low-light conditions.
- Optional electronic captions automatically change according to the sport mode, eliminating the need for caption panels.

[WWW.DAKTRONICS.COM](http://WWW.DAKTRONICS.COM) E-MAIL: [SALES@DAKTRONICS.COM](mailto:SALES@DAKTRONICS.COM)

201 Daktronics Drive, PO Box 5128, Brookings, SD 57006  
 Phone: 1-800-325-8766 or 605-692-0200 Fax: 605-697-4746  
 DD2216211 071015 Page 1 of 12



# MODULAR FB SCOREBOARDS PRODUCT SPECIFICATIONS

CLOCKS	DIMENSIONS (HEIGHT, WIDTH, DEPTH)	UNCRATED WEIGHT	POWER* (WATTS)	DIGIT SIZE
FB-2500	H 3'-7.2", W 7'-2.4", D 8" (1.1 m, 2.2 m, 203 mm)	130 lb (59 kg)	R/A = 300 W = 250	24" (610 mm)
FB-2501	H 3'-7.2", W 9'-7.2", D 8" (1.1 m, 2.93 m, 203 mm)	173 lb (79 kg)	R/A = 300 W = 350	30" (762 mm)
FB-2502	H 3'-7.2", W 10'-9.6", D 8" (1.1 m, 3.29 m, 203 mm)	195 lb (89 kg)	R/A = 200 W = 400	36" (914 mm)
FB-2503	H 4'-9.6", W 7'-2.4", D 8" (1.46 m, 2.2 m, 203 mm)	173 lb (79 kg)	R/A = 300 W = 250	24" (610 mm)
FB-2504	H 4'-9.6", W 9'-7.2", D 8" (1.46 m, 2.93 m, 203 mm)	231 lb (105 kg)	R/A = 300 W = 350	30" (762 mm)
FB-2505	H 4'-9.6", W 10'-9.6", D 8" (1.46 m, 3.29 m, 203 mm)	260 lb (118 kg)	R/A = 200 W = 400	36" (914 mm)
FB-2506	H 3'-7.2", W 10'-9.6", D 8" (1.1 m, 3.29 m, 203 mm)	195 lb (89 kg)	R/A = 300 W = 250	24" (610 mm)
FB-2507	H 3'-7.2", W 14'-4.8", D 8" (1.1 m, 4.39 m, 203 mm)	260 lb (118 kg)	R/A = 300 W = 350	30" (762 mm)
FB-2508	H 3'-7.2", W 15'-7.2", D 8" (1.1 m, 4.76 m, 203 mm)	281 lb (128 kg)	R/A = 350 W = 650	36" (914 mm)
FB-2509	H 4'-9.6", W 10'-9.6", D 8" (1.46 m, 3.29 m, 203 mm)	260 lb (118 kg)	R/A = 300 W = 250	24" (610 mm)
FB-2510	H 4'-9.6", W 14'-4.8", D 8" (1.46 m, 4.39 m, 203 mm)	346 lb (157 kg)	R/A = 300 W = 350	30" (762 mm)
FB-2511	H 4'-9.6", W 15'-7.2", D 8" (1.46 m, 4.76 m, 203 mm)	375 lb (170 kg)	R/A = 350 W = 650	36" (914 mm)
FB-2513	H 4'-9.6", W 14'-4.8", D 8" (1.46 m, 4.39 m, 203 mm)	346 lb (157 kg)	R/A = 350 W = 650	48" (1.22 m)



FB-2500



FB-2501



FB-2502



FB-2503\*



FB-2504



FB-2505

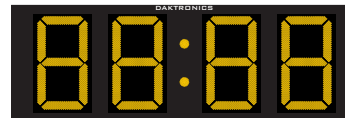

FB-2513



FB-2506



FB-2507



FB-2508



FB-2509\*



FB-2510\*



FB-2511\*

\*Sections with 30" or smaller digits are shown with a max of 300 W. Sections with 36" or larger digits and all sections with white digits include a 1000 W power supply and actual digit power consumption is shown.

[WWW.DAKTRONICS.COM](http://WWW.DAKTRONICS.COM) E-MAIL: [SALES@DAKTRONICS.COM](mailto:SALES@DAKTRONICS.COM)

201 Daktronics Drive, PO Box 5128, Brookings, SD 57006  
 Phone: 1-800-325-8766 or 605-692-0200 Fax: 605-697-4746  
 DD2216211 071015 Page 2 of 12



# MODULAR FB SCOREBOARDS PRODUCT SPECIFICATIONS

HOME SCORE	DIMENSIONS (HEIGHT, WIDTH, DEPTH)	UNCRATED WEIGHT	POWER* (WATTS)	DIGIT SIZE	OPTIONAL TNMC SIZE
FB-2530	H 4'-9.6", W 7'-2.4", D 8" (1.46 m, 2.2 m, 203 mm)	173 lb (79 kg)	R/A = 300 W = 150	24" (610 mm)	8x48-34mm
FB-2531	H 3'-7.2", W 7'-2.4", D 8" (1.1 m, 2.2 m, 203 mm)	130 lb (59 kg)	(power from score section)	18" (457 mm)	N/A
FB-2532	H 4'-9.6", W 7'-2.4", D 8" (1.46 m, 2.2 m, 203 mm)	173 lb (79 kg)	R/A = 300 W = 150	30" (762 mm)	8x48-34mm
FB-2533	H 3'-7.2", W 7'-2.4", D 8" (1.1 m, 2.2 m, 203 mm)	130 lb (59 kg)	(power from score section)	24" (610 mm)	N/A
FB-2535	H 3'-7.2", W 9'-7.2", D 8" (1.1 m, 2.93 m, 203 mm)	173 lb (79 kg)	R/A = 200 W = 350	36" (914 mm)	N/A
FB-2536	H 3'-7.2", W 9'-7.2", D 8" (1.1 m, 2.93 m, 203 mm)	173 lb (79 kg)	(power from score section)	30" (762 mm)	N/A
FB-2537	H 4'-9.6", W 9'-7.2", D 8" (1.46 m, 2.93 m, 203 mm)	231 lb (105 kg)	R/A = 300 W = 150	24" (610 mm)	8x48-46mm
FB-2538	H 3'-7.2", W 9'-7.2", D 8" (1.1 m, 2.93 m, 203 mm)	173 lb (79 kg)	(power from score section)	18" (457 mm)	N/A
FB-2539	H 4'-9.6", W 9'-7.2", D 8" (1.46 m, 2.93 m, 203 mm)	231 lb (105 kg)	R/A = 300 W = 150	30" (762 mm)	8x48-46mm
FB-2540	H 3'-7.2", W 9'-7.2", D 8" (1.1 m, 2.93 m, 203 mm)	173 lb (79 kg)	(power from score section)	24" (610 mm)	N/A
FB-2542	H 4'-9.6", W 9'-7.2", D 8" (1.46 m, 2.93 m, 203 mm)	231 lb (105 kg)	R/A = 200 W = 350	36" (914 mm)	N/A
FB-2544	H 4'-9.6", W 9'-7.2", D 8" (1.46 m, 2.93 m, 203 mm)	231 lb (105 kg)	R/A = 250 W = 500	48" (1.22 mm)	N/A
FB-2545	H 3'-7.2", W 9'-7.2", D 8" (1.1 m, 2.93 m, 203 mm)	173 lb (79 kg)	(power from score section)	36" (914 mm)	N/A
FB-2546	H 4'-9.6", W 8'-4.8", D 8" (1.46 m, 2.56 m, 203 mm)	202 lb (92 kg)	R/A = 300 W = 150	24" (610 mm)	8x48-34mm
FB-2547	H 3'-7.2", W 8'-4.8", D 8" (1.1 m, 2.56 m, 203 mm)	152 lb (69 kg)	(power from score section)	18" (457 mm)	N/A
FB-2560	H 4'-9.6", W 14'-4.8", D 8" (1.46 m, 4.39 m, 203 mm)	346 lb (157 kg)	R/A = 300 W = 150	24" (610 mm) 18" (457 mm)	8x48-34mm
FB-2561	H 4'-9.6", W 14'-4.8", D 8" (1.46 m, 4.39 m, 203 mm)	346 lb (157 kg)	R/A = 300 W = 150	30" (762 mm) 24" (610 mm)	8x48-34mm
FB-2562	H 4'-9.6", W 16'-9.6", D 8" (1.46 m, 5.12 m, 203 mm)	404 lb (184 kg)	R/A = 300 W = 150	24" (610 mm) 18" (457 mm)	8x48-46mm
FB-2563	H 4'-9.6", W 16'-9.6", D 8" (1.46 m, 5.12 m, 203 mm)	404 lb (184 kg)	R/A = 300 W = 150	30" (762 mm) 24" (610 mm)	8x48-46mm
FB-2564	H 4'-9.6", W 28'-9.6", D 8" (1.46 m, 8.78 m, 203 mm)	692 lb (314 kg)	R/A = 200 W = 300	36" (914 mm) 30" (762 mm)	16x80-34mm
FB-2565	H 3'-7.2", W 28'-9.6", D 8" (1.1 m, 8.78 m, 203 mm)	519 lb (236 kg)	R/A = 200 W = 300	36" (914 mm) 30" (762 mm)	8x48-46mm
FB-2566	H 3'-7.2", W 16'-9.6", D 8" (1.1 m, 5.12 m, 203 mm)	303 lb (138 kg)	R/A = 300 W = 150	24" (610 mm) 18" (457 mm)	8x48-34mm

\*Sections with 30" or smaller digits are shown with a max of 300 W. Sections with 36" or larger digits and all sections with white digits include a 1000 W power supply and actual digit power consumption is shown.

[WWW.DAKTRONICS.COM](http://WWW.DAKTRONICS.COM) E-MAIL: [SALES@DAKTRONICS.COM](mailto:SALES@DAKTRONICS.COM)

201 Daktronics Drive, PO Box 5128, Brookings, SD 57006  
Phone: 1-800-325-8766 or 605-692-0200 Fax: 605-697-4746  
DD2216211 071015 Page 3 of 12



# MODULAR FB SCOREBOARDS PRODUCT SPECIFICATIONS

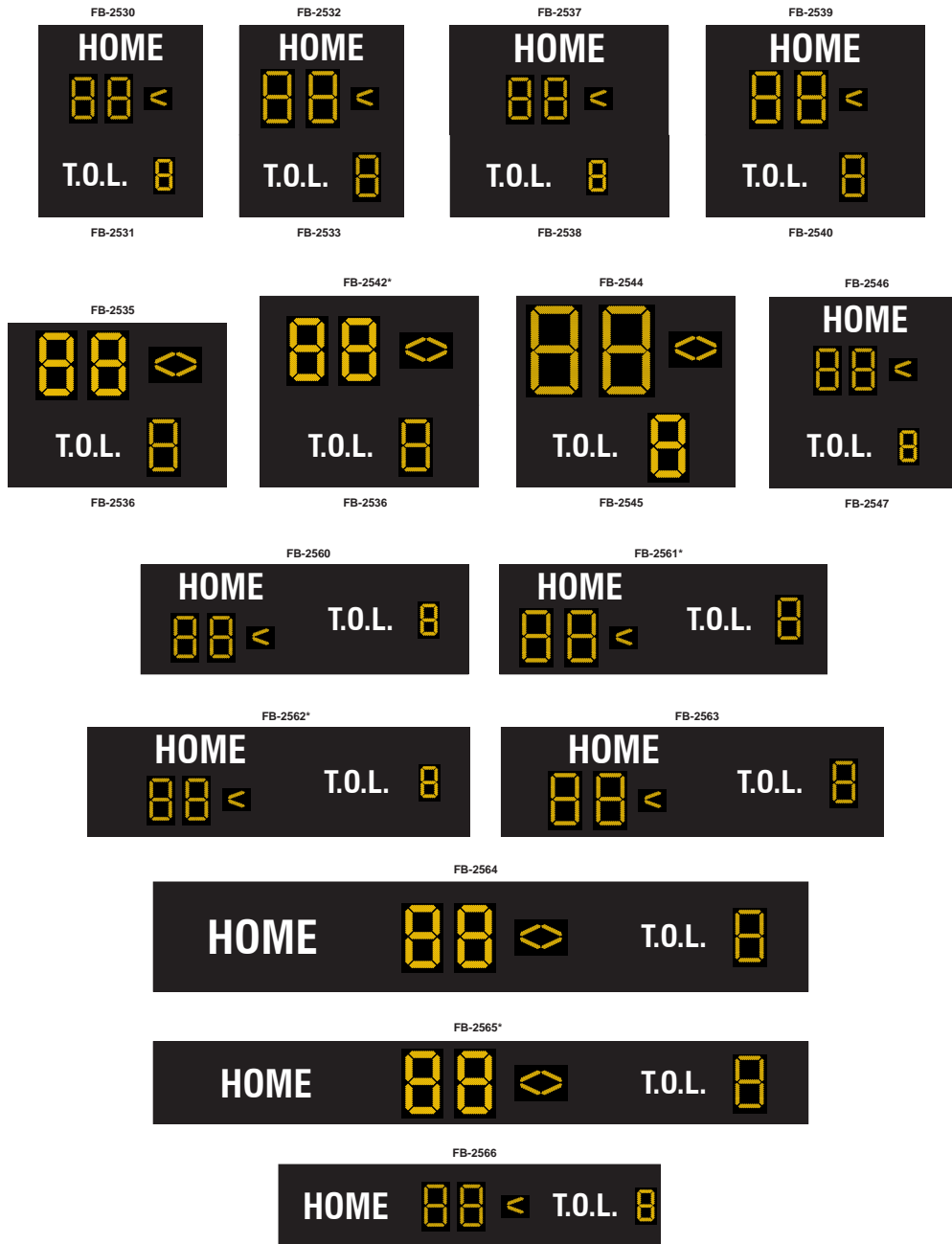

FB-2536 is shown twice to demonstrate how it can work with different scoring sections.

All Home score models come with choice of vinyl, backlit, or electronic captions.



[WWW.DAKTRONICS.COM](http://WWW.DAKTRONICS.COM) E-MAIL: [SALES@DAKTRONICS.COM](mailto:SALES@DAKTRONICS.COM)

201 Daktronics Drive, PO Box 5128, Brookings, SD 57006  
 Phone: 1-800-325-8766 or 605-692-0200 Fax: 605-697-4746  
 DD2216211 071015 Page 4 of 12





# MODULAR FB SCOREBOARDS PRODUCT SPECIFICATIONS

GUEST SCORE	DIMENSIONS (HEIGHT, WIDTH, DEPTH)	UNCRATED WEIGHT	POWER* (WATTS)	DIGIT SIZE	OPTIONAL TNMC SIZE
FB-2570	H 4'-9.6", W 7'-2.4", D 8" (1.46 m, 2.2 m, 203 mm)	173 lb (79 kg)	R/A = 300 W = 150	24" (610 mm)	8x48-34mm
FB-2571	H 3'-7.2", W 7'-2.4", D 8" (1.1 m, 2.2 m, 203 mm)	130 lb (59 kg)	(power from score section)	18" (457 mm)	N/A
FB-2572	H 4'-9.6", W 7'-2.4", D 8" (1.46 m, 2.2 m, 203 mm)	173 lb (79 kg)	R/A = 300 W = 150	30" (762 mm)	8x48-34mm
FB-2573	H 3'-7.2", W 7'-2.4", D 8" (1.1 m, 2.2 m, 203 mm)	130 lb (59 kg)	(power from score section)	24" (610 mm)	N/A
FB-2574	H 3'-7.2", W 9'-7.2", D 8" (1.1 m, 2.93 m, 203 mm)	173 lb (79 kg)	R/A = 200 W = 350	36" (914 mm)	N/A
FB-2575	H 3'-7.2", W 9'-7.2", D 8" (1.1 m, 2.93 m, 203 mm)	173 lb (79 kg)	(power from score section)	30" (762 mm)	N/A
FB-2576	H 4'-9.6", W 9'-7.2", D 8" (1.46 m, 2.93 m, 203 mm)	231 lb (105 kg)	R/A = 300 W = 150	24" (610 mm)	8x48-46mm
FB-2577	H 3'-7.2", W 9'-7.2", D 8" (1.1 m, 2.93 m, 203 mm)	173 lb (79 kg)	(power from score section)	18" (457 mm)	N/A
FB-2578	H 4'-9.6", W 9'-7.2", D 8" (1.46 m, 2.93 m, 203 mm)	231 lb (105 kg)	R/A = 300 W = 150	30" (762 mm)	8x48-46mm
FB-2579	H 3'-7.2", W 9'-7.2", D 8" (1.1 m, 2.93 m, 203 mm)	173 lb (79 kg)	(power from score section)	24" (610 mm)	N/A
FB-2580	H 4'-9.6", W 9'-7.2", D 8" (1.46 m, 2.93 m, 203 mm)	231 lb (105 kg)	R/A = 200 W = 350	36" (914 mm)	N/A
FB-2582	H 4'-9.6", W 9'-7.2", D 8" (1.46 m, 2.93 m, 203 mm)	231 lb (105 kg)	R/A = 250 W = 500	48" (1.22 mm)	N/A
FB-2583	H 3'-7.2", W 9'-7.2", D 8" (1.1 m, 2.93 m, 203 mm)	173 lb (79 kg)	(power from score section)	36" (914 mm)	N/A
FB-2584	H 4'-9.6", W 8'-4.8", D 8" (1.46 m, 2.56 m, 203 mm)	202 lb (92 kg)	R/A = 300 W = 150	24" (610 mm)	8x48-34mm
FB-2585	H 3'-7.2", W 8'-4.8", D 8" (1.1 m, 2.56 m, 203 mm)	152 lb (69 kg)	(power from score section)	18" (457 mm)	N/A
FB-2600	H 4'-9.6", W 14'-4.8", D 8" (1.46 m, 4.39 m, 203 mm)	346 lb (157 kg)	R/A = 300 W = 150	24" (610 mm) 18" (457 mm)	8x48-34mm
FB-2601	H 4'-9.6", W 14'-4.8", D 8" (1.46 m, 4.39 m, 203 mm)	346 lb (157 kg)	R/A = 300 W = 150	30" (762 mm) 24" (610 mm)	8x48-34mm
FB-2602	H 4'-9.6", W 16'-9.6", D 8" (1.46 m, 5.12 m, 203 mm)	404 lb (184 kg)	R/A = 300 W = 150	24" (610 mm) 18" (457 mm)	8x48-46mm
FB-2603	H 4'-9.6", W 16'-9.6", D 8" (1.46 m, 5.12 m, 203 mm)	404 lb (184 kg)	R/A = 300 W = 150	30" (762 mm) 24" (610 mm)	8x48-46mm
FB-2604	H 4'-9.6", W 28'-9.6", D 8" (1.46 m, 8.78 m, 203 mm)	692 lb (314 kg)	R/A = 200 W = 300	36" (914 mm) 30" (762 mm)	16x80-34mm
FB-2605	H 3'-7.2", W 28'-9.6", D 8" (1.1 m, 8.78 m, 203 mm)	519 lb (236 kg)	R/A = 200 W = 300	36" (914 mm) 30" (762 mm)	8x48-46mm
FB-2606	H 3'-7.2", W 16'-9.6", D 8" (1.1 m, 5.12 m, 203 mm)	303 lb (138 kg)	R/A = 300 W = 150	24" (610 mm) 18" (457 mm)	8x48-34mm

\*Sections with 30" or smaller digits are shown with a max of 300 W. Sections with 36" or larger digits and all sections with white digits include a 1000 W power supply and actual digit power consumption is shown.

[WWW.DAKTRONICS.COM](http://WWW.DAKTRONICS.COM) E-MAIL: [SALES@DAKTRONICS.COM](mailto:SALES@DAKTRONICS.COM)

201 Daktronics Drive, PO Box 5128, Brookings, SD 57006  
Phone: 1-800-325-8766 or 605-692-0200 Fax: 605-697-4746  
DD2216211 071015 Page 5 of 12



# MODULAR FB SCOREBOARDS PRODUCT SPECIFICATIONS

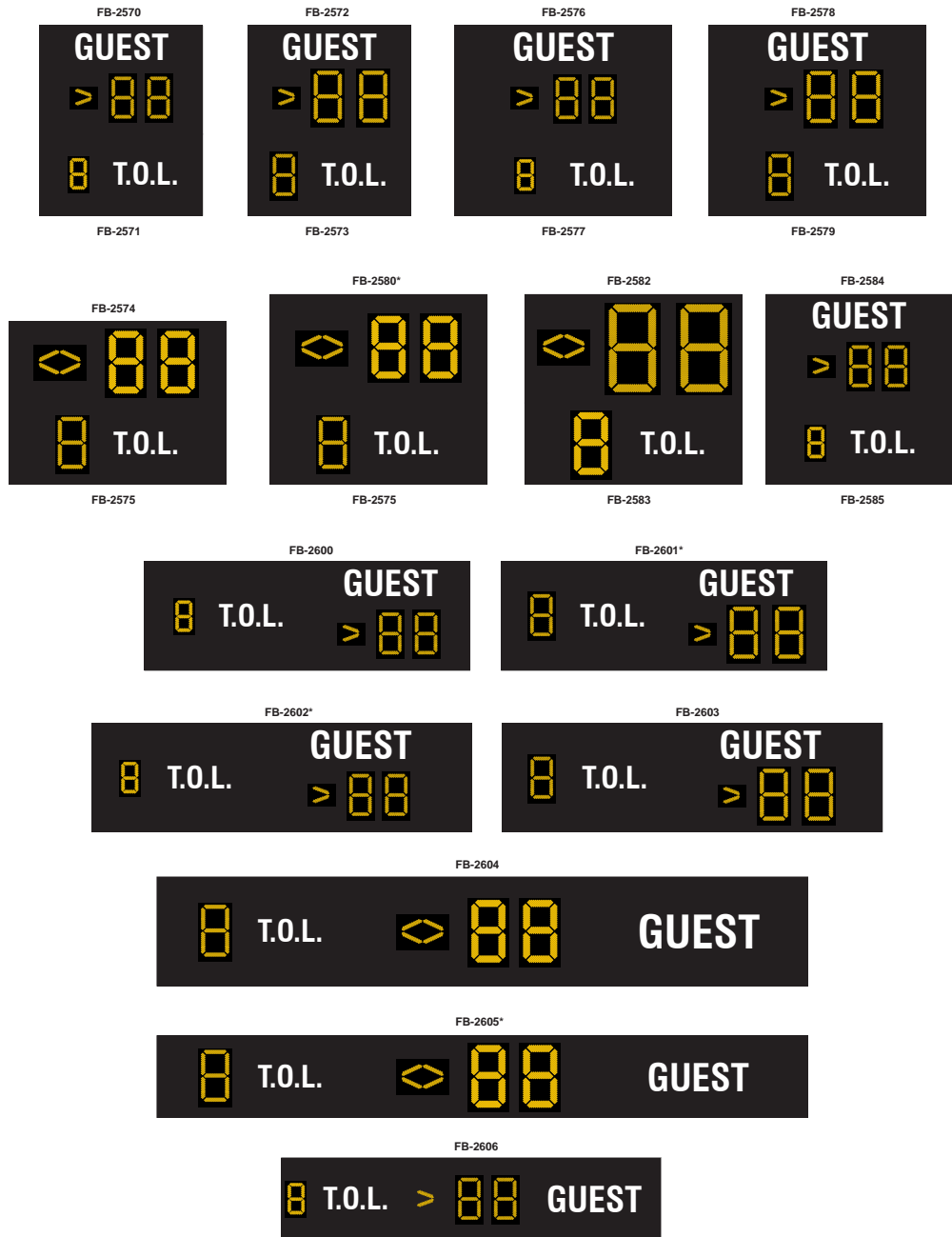

FB-2575 is shown twice to demonstrate how it can work with different scoring sections.

All Guest score models come with choice of vinyl, backlit, or electronic captions.



# MODULAR FB SCOREBOARDS PRODUCT SPECIFICATIONS

All HOME & GUEST T.O.L. sections are available with backlit captions or electronic captions:

- One backlit caption adds 20 lb (9 kg) to overall weight and 150 W to overall power.
- One 8x32-34mm electronic caption adds 40 lb (18 kg) to overall weight and 150 W to overall power.
- Electronic caption LEDs are typically the same color as the LED digits on the other scoreboard sections.

TNMCs are available in three different sizes, depending on the model as noted in the previous tables:

- One 8x48-34mm TNMC adds 60 lb (27 kg) to overall weight and 150 W (300 W for white) to overall power.
- One 8x48-46mm TNMC adds 70 lb (32 kg) to overall weight and 150 W (300 W for white) to overall power.
- One 16x80-34mm TNMC adds 100 lb (45 kg) to overall weight and 300 W (450 W for white) to overall power.
- TNMC LEDs are typically the same color as the LED digits on the other scoreboard sections.

Backlit captions for team names are available in three different sizes:

- One small team name backlit caption adds 32 lb (15 kg) to overall weight and 250 W to overall power.
- One medium team name backlit caption adds 45 lb (21 kg) to overall weight and 300 W to overall power.
- One large team name backlit caption adds 65 lb (30 kg) to overall weight and 350 W to overall power.

When sections are stacked one on top of the other, the T.O.L. sections will always be directly below the scoring sections.

TEAM NAME	DIMENSIONS (HEIGHT, WIDTH, DEPTH)	UNCRATED WEIGHT	POWER	OPTIONAL TNMC SIZE
FB-2534	H 3'-7.2", W 9'-7.2", D 8" (1.1 m, 2.93 m, 203 mm)	173 lb (79 kg)	(see below)	8x48-46mm
FB-2541	H 3'-7.2", W 9'-7.2", D 8" (1.1 m, 2.93 m, 203 mm)	173 lb (79 kg)	(see below)	16x80-34mm

- One 8x48-46mm TNMC adds 70 lb (32 kg) to overall weight and requires 150 W (300 W white) power.
- One 16x80-34mm TNMC adds 100 lb (45 kg) to overall weight and requires 150 W (red), 300 W (amber), or 450 W (white) power.
- TNMC LEDs are typically the same color as the LED digits on the other scoreboard sections.

Backlit captions for team names are available in two different sizes:

- One medium team name backlit caption adds 45 lb (21 kg) to overall weight and 300 W to overall power.
- One large team name backlit caption adds 65 lb (30 kg) to overall weight and 350 W to overall power.

When sections are stacked one on top of the other, the team name sections will always be directly above the scoring sections.

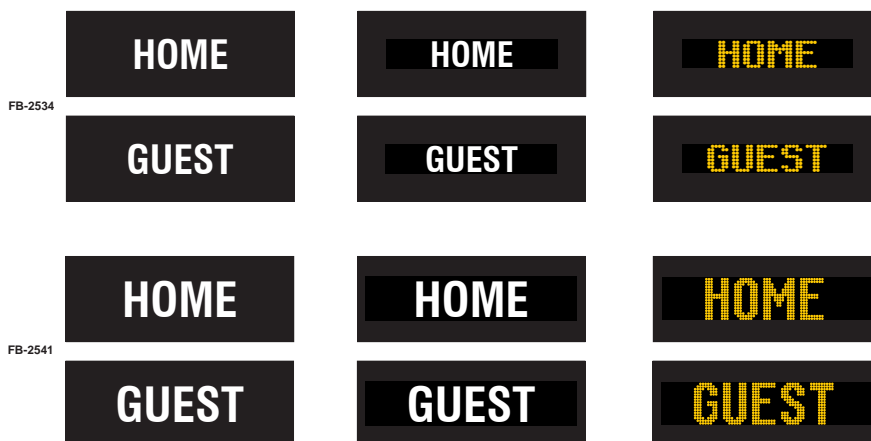

# MODULAR FB SCOREBOARDS PRODUCT SPECIFICATIONS

DOWN/TO GO & BALL ON/QTR	DIMENSIONS (HEIGHT, WIDTH, DEPTH)	UNCRATED WEIGHT	POWER* (WATTS)	DIGIT SIZE
FB-2610	H 3'-7.2", W 7'-2.4", D 8" (1.1 m, 2.2 m, 203 mm)	130 lb (59 kg)	R/A = 300 W = 150	24" (610 mm)
FB-2611	H 3'-7.2", W 7'-2.4", D 8" (1.1 m, 2.2 m, 203 mm)	130 lb (59 kg)	R/A = 300 W = 150	24" (610 mm)
FB-2612	H 3'-7.2", W 16'-9.6", D 8" (1.1 m, 5.12 m, 203 mm)	303 lb (138 kg)	R/A = 300 W = 150	24" (610 mm)
FB-2613	H 3'-7.2", W 16'-9.6", D 8" (1.1 m, 5.12 m, 203 mm)	303 lb (138 kg)	R/A = 300 W = 150	24" (610 mm)
FB-2614	H 3'-7.2", W 16'-9.6", D 8" (1.1 m, 5.12 m, 203 mm)	303 lb (138 kg)	R/A = 300 W = 150	30" (762 mm)
FB-2615	H 3'-7.2", W 16'-9.6", D 8" (1.1 m, 5.12 m, 203 mm)	303 lb (138 kg)	R/A = 300 W = 150	30" (762 mm)
FB-2616	H 3'-7.2", W 16'-9.6", D 8" (1.1 m, 5.12 m, 203 mm)	303 lb (138 kg)	R/A = 150 W = 300	36" (914 mm)
FB-2617	H 3'-7.2", W 16'-9.6", D 8" (1.1 m, 5.12 m, 203 mm)	303 lb (138 kg)	R/A = 150 W = 300	36" (914 mm)
FB-2618	H 3'-7.2", W 9'-7.2", D 8" (1.1 m, 2.93 m, 203 mm)	173 lb (79 kg)	(power from FB-2620)	36" (914 mm)
FB-2619	H 3'-7.2", W 9'-7.2", D 8" (1.1 m, 2.93 m, 203 mm)	173 lb (79 kg)	R/A = 150 W = 350	36" (914 mm)
FB-2620	H 3'-7.2", W 9'-7.2", D 8" (1.1 m, 2.93 m, 203 mm)	173 lb (79 kg)	R/A = 150 W = 350	36" (914 mm)
FB-2621	H 3'-7.2", W 9'-7.2", D 8" (1.1 m, 2.93 m, 203 mm)	173 lb (79 kg)	(power from FB-2619)	36" (914 mm)
FB-2622	H 4'-9.6", W 8'-4.8", D 8" (1.46 m, 2.56 m, 203 mm)	202 lb (92 kg)	R/A = 300 W = 150	24" (610 mm)
FB-2623	H 4'-9.6", W 8'-4.8", D 8" (1.46 m, 2.56 m, 203 mm)	202 lb (92 kg)	R/A = 300 W = 150	24" (610 mm)
FB-2624	H 4'-9.6", W 9'-7.2", D 8" (1.46 m, 2.93 m, 203 mm)	231 lb (105 kg)	R/A = 300 W = 150	30" (762 mm)
FB-2625	H 4'-9.6", W 9'-7.2", D 8" (1.46 m, 2.93 m, 203 mm)	231 lb (105 kg)	R/A = 300 W = 150	30" (762 mm)
FB-2626	H 4'-9.6", W 16'-9.6", D 8" (1.46 m, 5.12 m, 203 mm)	404 lb (184 kg)	R/A = 150 W = 300	36" (914 mm)
FB-2627	H 4'-9.6", W 16'-9.6", D 8" (1.46 m, 5.12 m, 203 mm)	404 lb (184 kg)	R/A = 150 W = 300	36" (914 mm)
FB-2628	H 4'-9.6", W 9'-7.2", D 8" (1.46 m, 2.93 m, 203 mm)	231 lb (105 kg)	(power from FB-2630)	36" (914 mm)
FB-2629	H 4'-9.6", W 9'-7.2", D 8" (1.46 m, 2.93 m, 203 mm)	231 lb (105 kg)	R/A = 150 W = 350	36" (914 mm)
FB-2630	H 4'-9.6", W 9'-7.2", D 8" (1.46 m, 2.93 m, 203 mm)	231 lb (105 kg)	R/A = 150 W = 350	36" (914 mm)
FB-2631	H 4'-9.6", W 9'-7.2", D 8" (1.46 m, 2.93 m, 203 mm)	231 lb (105 kg)	(power from FB-2629)	36" (914 mm)
FB-2632	H 4'-9.6", W 9'-7.2", D 8" (1.46 m, 2.93 m, 203 mm)	231 lb (105 kg)	R/A = 300 W = 150	24" (610 mm)
FB-2633	H 4'-9.6", W 9'-7.2", D 8" (1.46 m, 2.93 m, 203 mm)	231 lb (105 kg)	R/A = 300 W = 150	24" (610 mm)

# MODULAR FB SCOREBOARDS PRODUCT SPECIFICATIONS

DOWN/TO GO & BALL ON/QTR	DIMENSIONS (HEIGHT, WIDTH, DEPTH)	UNCRATED WEIGHT	POWER* (WATTS)	DIGIT SIZE
FB-2656	H 4'-9.6", W 19'-2.4", D 8" (1.46 m, 5.85 m, 203 mm)	461 lb (210 kg)	R/A = 250 W = 500	48" (1.22 m)
FB-2657	H 4'-9.6", W 19'-2.4", D 8" (1.46 m, 5.85 m, 203 mm)	461 lb (210 kg)	R/A = 250 W = 500	48" (1.22 m)
FB-2658	H 4'-9.6", W 10'-9.6", D 8" (1.46 m, 3.29 m, 203 mm)	260 lb (118 kg)	(power from FB-2660)	48" (1.22 m)
FB-2659	H 4'-9.6", W 10'-9.6", D 8" (1.46 m, 3.29 m, 203 mm)	260 lb (118 kg)	R/A = 300 W = 700	48" (1.22 m)
FB-2660	H 4'-9.6", W 10'-9.6", D 8" (1.46 m, 3.29 m, 203 mm)	260 lb (118 kg)	R/A = 300 W = 700	48" (1.22 m)
FB-2661	H 4'-9.6", W 10'-9.6", D 8" (1.46 m, 3.29 m, 203 mm)	260 lb (118 kg)	(power from FB-2659)	48" (1.22 m)

\*Sections with 30" or smaller digits are shown with a max of 300 W. Sections with 36" or larger digits and all sections with white digits include a 1000 W power supply and actual digit power consumption is shown.

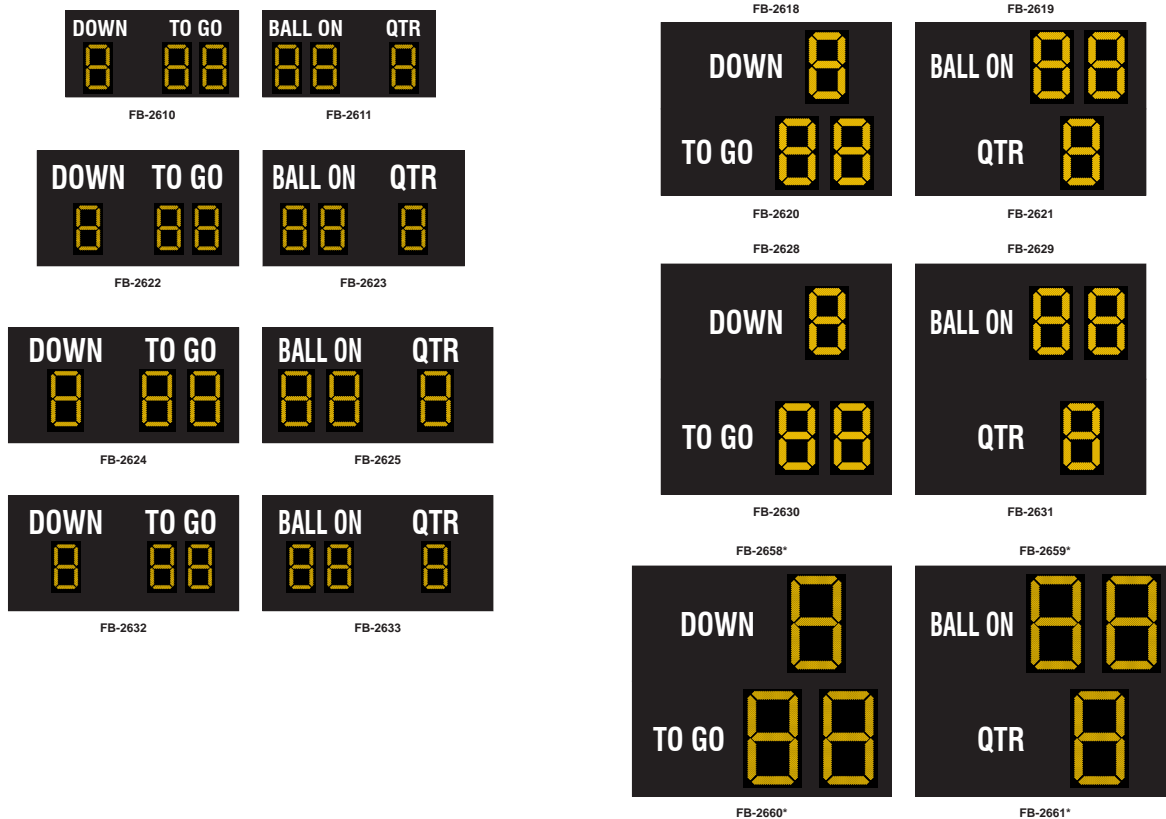

# MODULAR FB SCOREBOARDS PRODUCT SPECIFICATIONS



FB-2612



FB-2613



FB-2614



FB-2615



FB-2616



FB-2617



FB-2626



FB-2627



FB-2656\*



FB-2657\*

All DOWN/TO GO and BALL ON/QTR models come with choice of vinyl, backlit, or electronic captions.  
*(FB-2610 & FB-2611 not offered with electronic captions)*

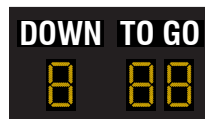

All sections are available with backlit or electronic captions in place of vinyl captions:

- One backlit caption adds 20 lb (9 kg) to overall weight and 150 W to overall power.
- One 8x32-34mm electronic caption adds 40 lb (18 kg) to overall weight and 150 W to overall power.
- Electronic caption LEDs are typically the same color as the LED digits on the other scoreboard sections.

With side-by-side DOWN/TO GO sections, DOWN will always be to the left of to go and they will both be incorporated into one cabinet. When sections are stacked one on top of the other, the DOWN section will always be above the to go section.

With side-by-side BALL ON/QTR sections, BALL ON will always be to the left of QTR and they will both be incorporated into one cabinet. When sections are stacked one on top of the other, the BALL ON section will always be above the QTR section.

# MODULAR FB SCOREBOARDS PRODUCT SPECIFICATIONS

CONTROL CONSOLE	CONTROL OPTIONS
<b>All Sport® 5000</b> (see <a href="#">SL-03991</a> )	<b>Wired (standard):</b> One-pair shielded cable of 22 AWG minimum is required. A cover plate with mounted connector and standard 2" x 4" x 2" (51 mm x 102 mm x 51 mm) outlet box is provided. Connector mates with signal cable from control console. ----- <b>Wireless (optional):</b> 2.4 GHz spread spectrum radio features 64 non-interfering channels and 8 broadcast groups (see <a href="#">SL-04370</a> ).
<b>OmniSport® 2000</b> (see <a href="#">SL-05408</a> )	<b>Optional</b> controller for semi-automatic push-button track timing only. An All Sport 5000 is still required for primary sport scoring functions.

## SEGMENT TIMER MODE

The segment timer mode is ideal for keeping practices on schedule. The horn at the end of a segment allows coaches and athletes to focus on the practice and to listen for the horn when it is time to change drills (see [SL-04004](#)).

## MOUNTING

Scoreboard is typically mounted on horizontal beams. Standard mounting uses I-beam clamps. Optional mounting method using angle brackets is also offered.

## SERVICE ACCESS

Digit panels and electronics are serviced from the front or rear of the scoreboard.

## GENERAL INFORMATION

Scoreboard provides scoring capabilities for two teams. 100% solid state electronics are housed in an all aluminum cabinet. Scoreboard is shipped in multiple sections. Specifications and pricing are subject to change without notice.

## OPTIONS & ACCESSORIES

- Scoreboard border striping
- Multiple caption and striping colors (see [DD2101644](#))
- Team name caption in place of HOME \*
- Programmable Team Name Message Centers (see [DD1696958](#))
- Backlit or electronic captions
- Lacrosse/field hockey, soccer, and track captions on changeable panels
- Horn
- Standalone Time of Day – scoreboard acts as a clock when control console is unplugged/off
- Advertising/Identification panels (see [SL-03761](#))
- Decorative accents
- Electronic message centers and video displays in multiple sizes

\* Only for scoreboard without Team Name Message Centers

## FOR ADDITIONAL INFORMATION

- Architectural Specifications: See [DD2216201](#)

# MODULAR FB SCOREBOARDS PRODUCT SPECIFICATIONS

## ALTERNATE CAPTIONS & SCORING MODES



Football Mode – vinyl, backlit & electronic captions shown

Track Mode, EVENT/HEAT – vinyl, backlit & electronic captions shown

Track Mode, GUEST 2/GUEST 3 – vinyl, backlit & electronic captions shown



Soccer Mode – vinyl, backlit & electronic captions shown (SHOTS displayed with electronic captions)

Lacrosse/Field Hockey Mode – vinyl, backlit & electronic captions shown (SHOTS & PER displayed with electronic captions)





## Appendix B: Reference Drawings

---

<i>Drawing Title</i>	<i>Drawing Number</i>
P1647; Pole Mounting Options .....	<b>A-1048184</b>
P1647 MTG Tube Assembly Detail .....	<b>A-1048268</b>
Ad Panel Pole Mounting .....	<b>B-1052388</b>
Ad Panel I-beam Clamp Mounting.....	<b>B-1052539</b>
P1647; I-beam Clamp Mounting.....	<b>A-1052565</b>



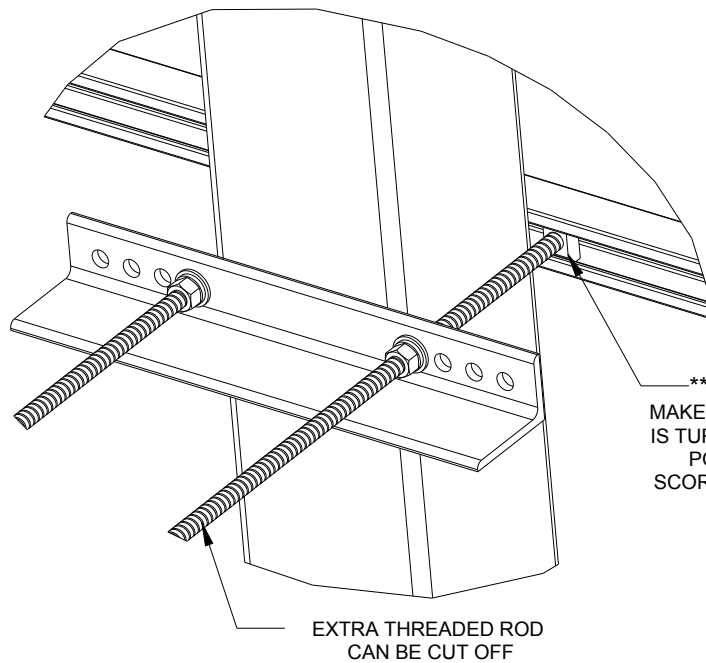
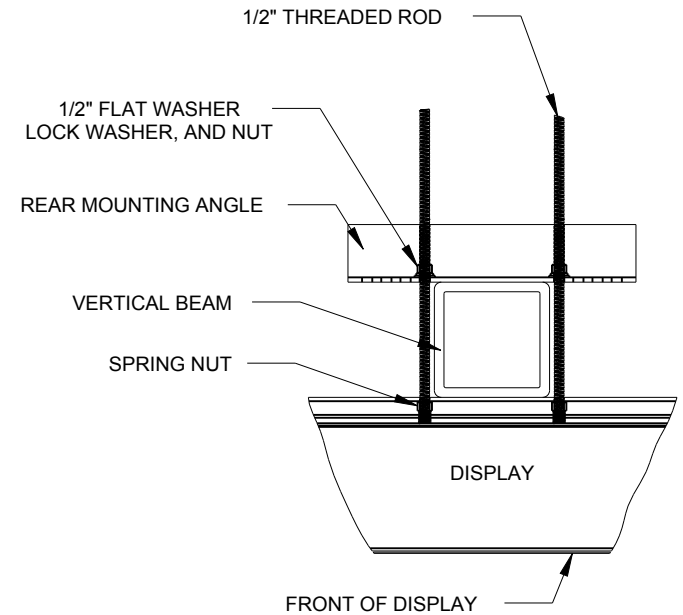
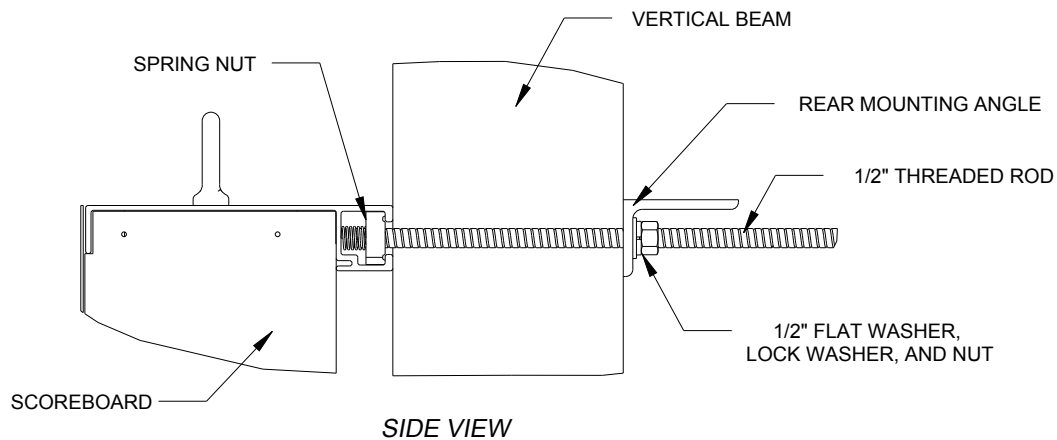

**\*\*\*CRITICAL\*\*\***  
 MAKE SURE SPRING NUT IS TURNED TO VERTICAL POSITION INSIDE SCOREBOARD CHANNEL

TOP VIEW  
 SCALE 1/10

**\*\*\*CRITICAL\*\*\***  
 DO NOT USE ANY LUBRICANT ON ANY MOUNTING HARDWARE OR WARRANTY WILL BE VOIDED

**STRUCTURAL NOTES:**  
 - BOLT TORQUE: 30 FT-LB

**NOTES:**  
 - THREADED RODS RUN ALONG BOTH SIDES OF BEAM  
 - RODS DO NOT PASS THROUGH THE FLANGES OF THE BEAM  
 - NO DRILLING NECESSARY  
 - MAKE SURE SPRING NUT IS PERPENDICULAR TO CHANNEL OPENING ON SCOREBOARD

04	22 DEC 15	ADDED LUBRICANT WARNING	PJS
03	03 JULY 13	ADDED STRUCTURAL NOTE	TTF
02	20 SEP 12	PER EC-7114; REMOVED CHAMFER FROM 0M-133259	LMG
01	06 OCT 11	REPLACED VERTICAL I-BEAM WITH 6" X 6" SQUARE TUBE	JAVA
REV	DATE:		BY:



THE CONCEPTS EXPRESSED AND DETAILS SHOWN ON THIS DRAWING ARE CONFIDENTIAL AND PROPRIETARY. DO NOT REPRODUCE BY ANY MEANS WITHOUT THE EXPRESS WRITTEN CONSENT OF DAKTRONICS, INC. OR ITS WHOLLY OWNED SUBSIDIARIES. COPYRIGHT 2016 DAKTRONICS, INC. (USA)

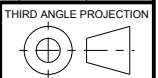

PROJECT: OUTDOOR SCOREBOARDS			
TITLE: P1647; POLE MOUNTING OPTIONS			
DATE: 22-DEC-15	DIM UNITS: INCHES [MILLIMETERS]	SHEET	REV
SCALE: 1/5	DO NOT SCALE DRAWING	1 OF 1	04
DESIGN: DOPPELT	JOB NO. P1647	FUNC - TYPE - SIZE E - 10 - A	1048184
DRAWN: DOPPELT			

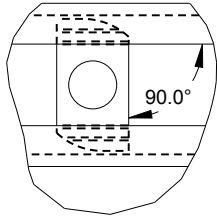

**REAR VIEW**  
 EXTRUSION W/SPRING NUT  
 MAKE SURE NUT IS AT ANGLE  
 TO EXTRUSION

INDEX	NAME	QTY	DESCRIPTION
1	HC-1095	4	WASHER, 1/2 FLAT, ZN PLTD, SAE
2	HC-1101	8	WASHER, 1/2 SPLIT LOCK, ZN PLTD, MEDIUM
3	HC-1152	8	Bolt; 1/2-13x1 1/2 Hex Head, Plated, Grade 5 Fully Threaded
4	HC-1575	4	WASHER, 1/2" USS FLAT ZINC PLATED
5	HS-1459	10	NUT INSERT; 1/2 - 13 OPEN END FOR 11/16 HOLE
6	HS-2098	2	CLIP ANGLE; DVX PLATFORM, 139.7MM X 279.4MM
7	HS-2194	4	SPRING NUT; 1/2"-13 THREAD; ZINC PLATED

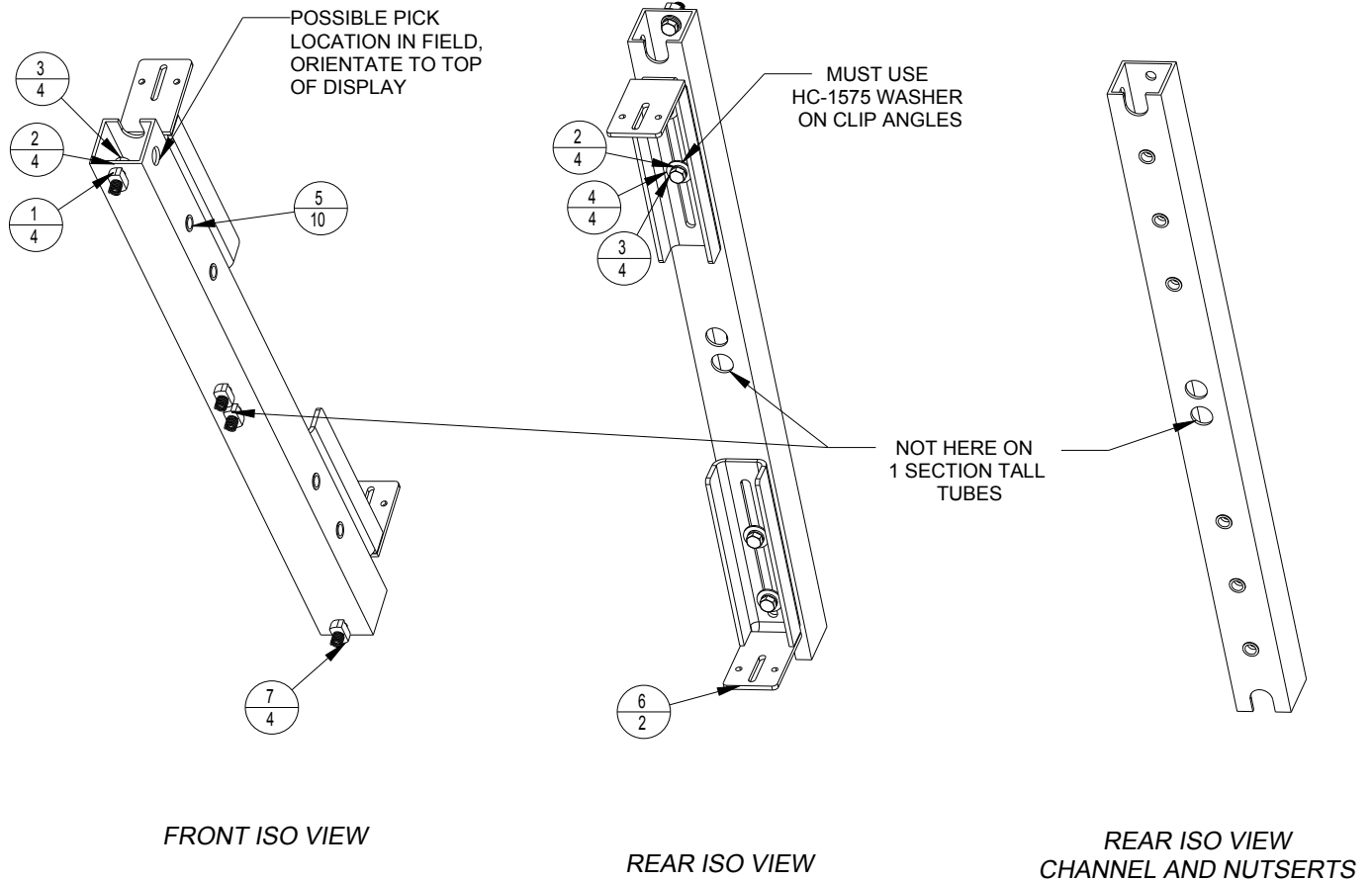

**NOTES:**  
 INSERT HS-1459 NUTSERTS @10 INTO TUBE  
 ATTACH HARDWARE AS SHOWN

MIDDLE CONNECTIONS INTO SCOREBOARDS  
 ONLY USED ON 2 SECTION TALL SCOREBOARDS

		DAKTRONICS, INC. BROOKINGS, SD 57006 DO NOT SCALE DRAWING		THE CONCEPTS EXPRESSED AND DETAILS SHOWN ON THIS DRAWING ARE CONFIDENTIAL AND PROPRIETARY. DO NOT REPRODUCE BY ANY MEANS WITHOUT THE EXPRESSED WRITTEN CONSENT OF DAKTRONICS, INC. COPYRIGHT 2011 DAKTRONICS, INC.	
PROJ: OUTDOOR SCOREBOARDS					
TITLE: P1647 MTG TUBE ASSEMBLY DETAIL					
DESIGN: DOPPELT		DRAWN: DOPPELT		DATE: 28-OCT-11	
SCALE: 1/10					
SHEET: 1 OF 1		REV: 01		JOB NO: P 1647	
				FUNC-TYPE-SIZE: E - 07 - A	
<b>1048268</b>					

01	28 OCT 11	ADDED NOTES	DRO
REV	DATE:		BY:

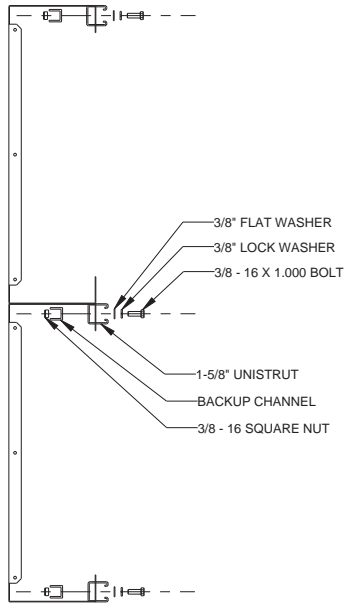

EXPLODED SIDE VIEW  
UNISTRUT ATTACHMENT

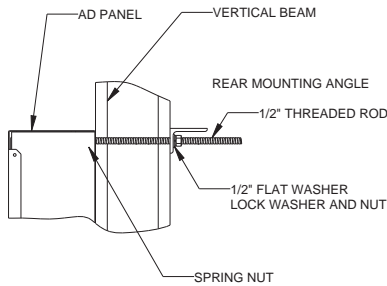

SIDE VIEW  
AD PANEL ATTACHMENT

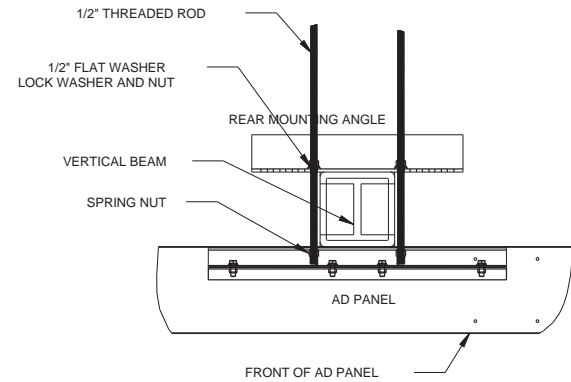

TOP VIEW  
AD PANEL ATTACHMENT

**\*\*\*CRITICAL\*\*\***  
DO NOT USE ANY LUBRICANT  
ON ANY MOUNTING HARDWARE  
OR WARRANTY WILL BE VOIDED

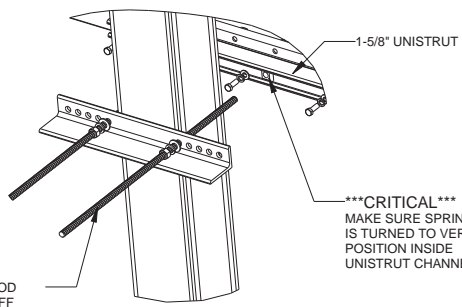

EXTRA THREADED ROD  
CAN BE CUT OFF

REAR ISOMETRIC VIEW

**MOUNTING INSTRUCTIONS:**

1. USING THE BACKUP CHANNEL AS A TEMPLATE, DRILL  $\varnothing 7/16"$  HOLES IN THE UPPER AND LOWER REAR FLANGE OF THE AD PANEL WHERE THE VERTICAL BEAMS WILL BE LOCATED.
2. IF AD PANEL HAS BACKSHEETS, REMOVE BACKSHEETS NECESSARY AT THIS TIME TO ACCESS HARDWARE FOR UNISTRUT ATTACHMENT
3. ATTACH UNISTRUT TO AD PANEL THROUGH HOLES DRILLED IN STEP 1 AS SHOWN IN UNISTRUT ATTACHMENT SIDE VIEW
4. REPLACE BACKSHEETS REMOVED IN STEP 2
5. PLACE SPRING NUTS INTO UNISTRUT IN APPROXIMATE LOCATION OF VERTICAL BEAMS
6. THREAD THE 1/2" THREADED ROD INTO THE SPRING NUTS
7. LIFT AD PANEL INTO POSITION
8. PLACE REAR MOUNTING ANGLES OVER EACH PAIR OF THREADED RODS AND SECURE AS SHOWN IN SIDE AND TOP VIEW AD PANEL ATTACHMENT
9. MAKE SURE THE THREADED ROD IS AS CLOSE TO THE VERTICAL BEAM AS POSSIBLE
10. WHEN AD PANEL IS ADJUSTED TO FINAL DESIRED POSITION, TIGHTEN NUTS FIRMLY

**NOTES:**

- THREADED RODS RUN ALONG BOTH SIDES OF BEAM
- RODS DO NOT PASS THROUGH THE FLANGE OF THE BEAM
- NO DRILLING REQUIRED
- MAKE SURE THE SPRING NUT IS PERPENDICULAR TO CHANNEL OPENING ON UNISTRUT

		<small>THE CONCEPTS EXPRESSED AND DETAILS SHOWN ON THIS DRAWING ARE CONFIDENTIAL AND PROPRIETARY. DO NOT REPRODUCE BY ANY MEANS WITHOUT THE EXPRESS WRITTEN CONSENT OF DAKTRONICS, INC. OR ITS WHOLLY OWNED SUBSIDIARIES. COPYRIGHT 2016 DAKTRONICS, INC. (USA)</small>			
<b>PROJECT: OUTDOOR SCOREBOARDS</b>					
<b>TITLE: AD PANEL POLE MOUNTING</b>					
DATE: 22-DEC-15		DIM UNITS: INCHES [MILLIMETERS]		SHEET 1 OF 1	
SCALE: 1/10		DO NOT SCALE DRAWING		REV 02	
DESIGN: MCARSRU	JOB NO. P1647	FUNC - TYPE - SIZE E - 10 - B		1052388	
DRAWN: MCARSRU					

02	22 DEC 15	ADDED LUBRICANT WARNING	PJS
01	18 SEP 12	REMOVED CHAMFER FROM 0M-133259 PER EC-7114	LMG
REV	DATE:		BY:

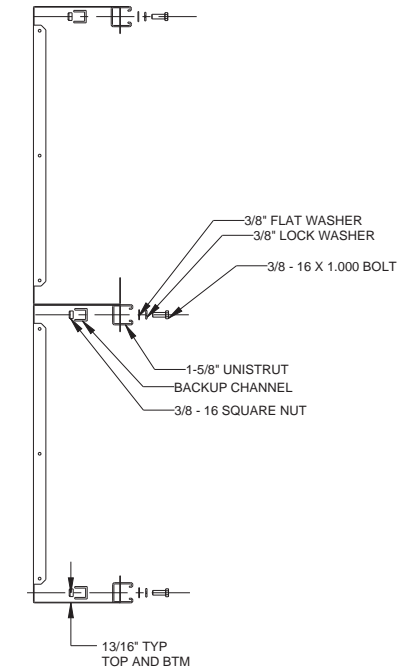

EXPLODED SIDE VIEW  
UNISTRUT ATTACHMENT

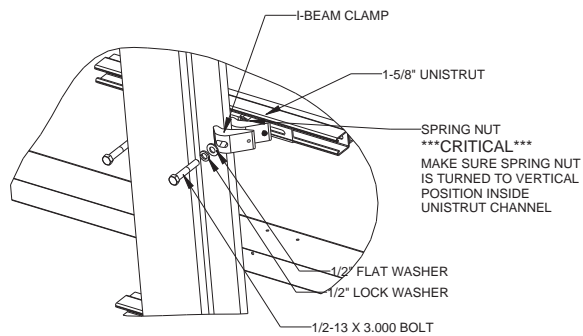

EXPLODED REAR ISOMETRIC VIEW  
AD PANEL ATTACHMENT

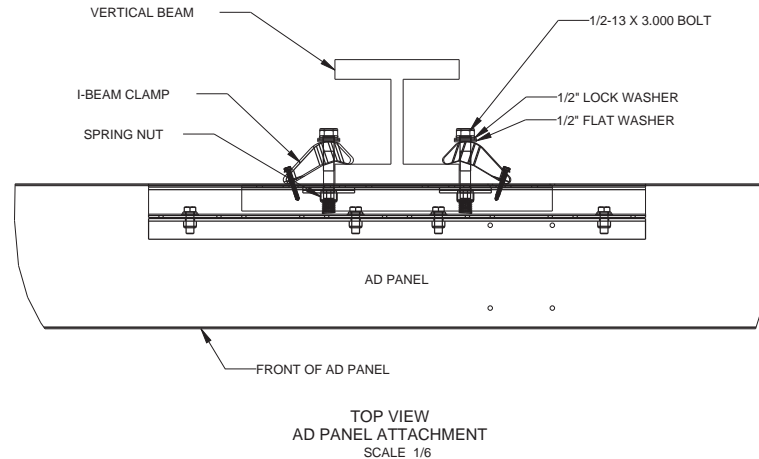

TOP VIEW  
AD PANEL ATTACHMENT  
SCALE 1/6

STRUCTURAL NOTES:

ALLOWABLE LOADS PER COLUMN CONNECTION

MAX ALLOWABLE WIND LOAD: 2,400 LBS  
 MAX ALLOWABLE PANEL WEIGHT: 158 LBS  
 COEFFICIENT OF FRICTION: 0.03  
 BOLT TORQUE: 50 FT-LB  
 MIN-MAX I-BEAM FLANGE THICKNESS: 0.25"-0.75"

**\*\*\*CRITICAL\*\*\***  
**DO NOT USE ANY LUBRICANT**  
**ON ANY MOUNTING HARDWARE**  
**OR WARRANTY WILL BE VOIDED**

MOUNTING INSTRUCTIONS:

1. USING THE BACKUP CHANNEL AS A TEMPLATE, DRILL  $\varnothing 7/16$ " HOLES IN THE UPPER AND LOWER REAR FLANGE OF THE AD PANEL WHERE THE VERTICAL BEAMS WILL BE LOCATED.
2. IF AD PANEL HAS BACKSHEETS, REMOVE BACKSHEETS NECESSARY AT THIS TIME TO ACCESS HARDWARE FOR UNISTRUT ATTACHMENT
3. ATTACH UNISTRUT TO AD PANEL THROUGH HOLES DRILLED IN STEP 1 AS SHOWN IN UNISTRUT ATTACHMENT SIDE VIEW
4. REPLACE BACKSHEETS REMOVED IN STEP 2
5. PLACE SPRING NUTS INTO UNISTRUT IN APPROXIMATE LOCATION OF VERTICAL BEAMS
7. LIFT AD PANEL INTO POSITION
8. ATTACH I-BEAM CLAMPS WITH 1/2" HARDWARE AS SHOWN IN TOP AND REAR ISOMETRIC VIEW AD PANEL ATTACHMENT
9. MAKE SURE THE 1/2-13 BOLTS ARE AS CLOSE TO THE I-BEAM FLANGES AS POSSIBLE
10. WHEN AD PANEL IS ADJUSTED TO FINAL DESIRED POSITION, TIGHTEN BOLTS FIRMLY

04	22 DEC 15	ADDED LUBRICANT WARNING	PJS		
03	17 APR 12	ADDED STACKED AD PANEL MOUNTING INSTRUCTIONS	JLR		
02	28 FEB 12	ADDED STRUCTURAL NOTES	MBC		
01	23 FEB 12	CHANGED ROCKER CLAMP/STOP TO I-BEAM CLAMP/STOP	KDD		
REV	DATE:		BY:		

  

		<small>THE CONCEPTS EXPRESSED AND DETAILS SHOWN ON THIS DRAWING ARE CONFIDENTIAL AND PROPRIETARY. DO NOT REPRODUCE BY ANY MEANS WITHOUT THE EXPRESS WRITTEN CONSENT OF DAKTRONICS, INC. OR ITS WHOLLY OWNED SUBSIDIARIES. COPYRIGHT 2016 DAKTRONICS, INC. (USA)</small>		<small>THIRD ANGLE PROJECTION</small>	
<b>PROJECT: OUTDOOR SCOREBOARDS</b>					
<b>TITLE: AD PANEL I-BEAM CLAMP MOUNTING</b>					
DATE: 22-DEC-15		DIM UNITS: INCHES [MILLIMETERS]		SHEET 1 OF 1	
SCALE: 1/10		DO NOT SCALE DRAWING		REV 04	
DESIGN: MCARSRU	JOB NO. P1647	FUNC - TYPE - SIZE	1052539		
DRAWN: MCARSRU		E - 07 - B			

VERTICAL BEAM - FLANGE THICKNESS MUST BE 1/4" - 3/4"  
 1/2-13 X 3.000 BOLT - BOLT THREAD MUST ENGAGE ENTIRE DEPTH OF SPRING NUT. BOLT MUST BE TIGHTENED TO 40FT-LB TORQUE  
 1/2" LOCK WASHER  
 1/2" FLAT WASHER  
 I-BEAM CLAMP - ASSURE CLAMP IS TIGHTLY ENGAGED TO I-BEAM AND NUT

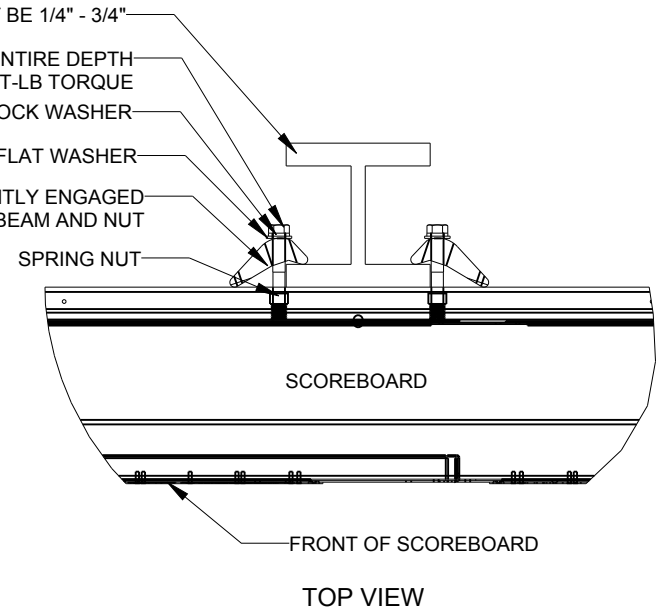

**\*\*\*CRITICAL\*\*\***  
 DO NOT USE ANY LUBRICANT ON ANY MOUNTING HARDWARE OR WARRANTY WILL BE VOIDED

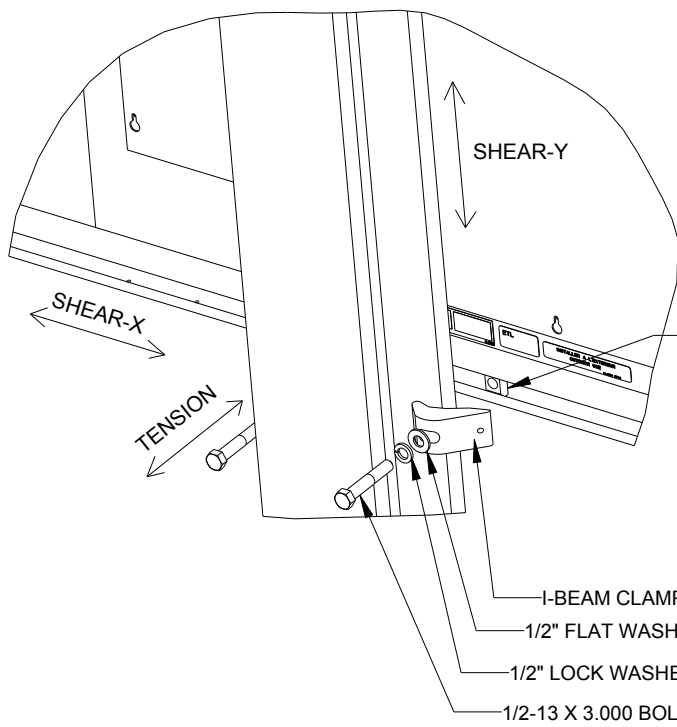

SPRING NUT  
**\*\*\*CRITICAL\*\*\***  
 MAKE SURE SPRING NUT IS TURNED TO VERTICAL POSITION INSIDE SCOREBOARD CHANNEL

EXPLODED REAR ISOMETRIC VIEW

05	22 DEC 15	ADDED LUBRICANT WARNING	PJS
04	06 JAN 14	ADDED ALLOWABLE TENSION AND SHEAR CAPACITY DETAILS	JAVA
03	23 OCT 13	PER EC-12382; CHANGED BOLT TORQUE FROM 30 FT-LB TO 40 FT-LB	NJM
02	07 MAR 12	ADDED STADNARD MOUNTING METHOD NOTES	KDD
01	21 FEB 12	CHANGED ROCKER TO I-BEAM	KDD
REV	DATE:		BY:

**DAKTRONICS**

THE CONCEPTS EXPRESSED AND DETAILS SHOWN ON THIS DRAWING ARE CONFIDENTIAL AND PROPRIETARY. DO NOT REPRODUCE BY ANY MEANS WITHOUT THE EXPRESS WRITTEN CONSENT OF DAKTRONICS, INC. OR ITS WHOLLY OWNED SUBSIDIARIES. COPYRIGHT 2016 DAKTRONICS, INC. (USA)

THIRD ANGLE PROJECTION

PROJECT: **OUTDOOR SCOREBOARD**

TITLE: **P1647; I-BEAM CLAMP MOUNTING**

DATE: **22-DEC-15** DIM UNITS: **INCHES [MILLIMETERS]** SHEET **1 OF 1** REV **05**

SCALE: **1/8** DO NOT SCALE DRAWING

DESIGN: **MCARSRU** JOB NO. **P1647** FUNC - TYPE - SIZE **E - 07 - A**

DRAWN: **MCARSRU** **1052565**

## STANDARD MOUNTING METHOD

- MOUNTING INSTRUCTIONS:
1. PLACE SPRING NUTS INTO SCOREBOARD CHANNEL IN APPROXIMATE LOCATION OF VERTICAL BEAMS
  2. LIFT SCOREBOARD INTO POSITION
  3. MAKE SURE THE 1/2-13 BOLTS ARE AS CLOSE TO THE I-BEAM FLANGES AS POSSIBLE
  4. WHEN SCOREBOARD IS ADJUSTED TO FINAL DESIRED POSITION, TIGHTEN BOLTS FIRMLY
  5. IF FLANGE THICKNESS IS MORE THAN 3/4" THICK LONGER BOLTS WILL BE REQUIRED AT THE CUSTOMER'S EXPENSE.

## STRUCTURAL NOTES

ALLOWABLE CAPACITY PER EACH CLAMP:  
 SHEAR = 160 LBS  
 TENSION = 2300 LBS

SHEAR AND TENSION LOAD DIRECTION ARE AS INDICATED ON REAR ISOMETRIC VIEW





## **Appendix C: Daktronics Warranty and Limitation of Liability**

---



**DAKTRONICS  
WARRANTY AND LIMITATION OF LIABILITY**

This Warranty and Limitation of Liability (the "Warranty") sets forth the warranty provided by Daktronics with respect to the Equipment. By accepting delivery of the Equipment, Purchaser agrees to be bound by and accept these terms and conditions. All defined terms within the Warranty shall have the same meaning and definition as provided elsewhere in the Agreement.

DAKTRONICS WILL ONLY BE OBLIGATED TO HONOR THE WARRANTY SET FORTH IN THESE TERMS AND CONDITIONS UPON RECEIPT OF FULL PAYMENT FOR THE EQUIPMENT.

**1. Warranty Coverage**

A. Daktronics warrants to the original end-user that the Equipment will be free from Defects (as defined below) in materials and workmanship for a period of one (1) year (the "Warranty Period"). The warranty period shall commence on the earlier of: (i) four weeks from the date that the equipment leaves Daktronics' facility; or (ii) Substantial Completion as defined herein. The warranty period shall expire on the first anniversary of the commencement date.

"Substantial Completion" means the operational availability of the Equipment to the Purchaser in accordance with the Equipment's specifications, without regard to punch-list items, or other non-substantial items which do not affect the operation of the Equipment.

B. Daktronics' obligation under this Warranty is limited to, at Daktronics' option, replacing or repairing, any Equipment or part thereof that is found by Daktronics not to conform to the Equipment's specifications. Unless otherwise directed by Daktronics, any defective part or component shall be returned to Daktronics for repair or replacement. Daktronics may, at its option, provide on-site warranty service. Daktronics shall have a reasonable period of time to make such replacements or repairs and all labor associated therewith shall be performed during regular working hours. Regular working hours are Monday through Friday between 8:00 a.m. and 5:00 p.m. at the location where labor is performed, excluding any holidays observed by either Purchaser or Daktronics.

C. Daktronics shall pay ground transportation charges for the return of any defective component of the Equipment. If returned Equipment is repaired or replaced under the terms of this warranty, Daktronics will prepay ground transportation charges back to Purchaser; otherwise, Purchaser shall pay transportation charges to return the Equipment back to the Purchaser. All returns must be pre-approved by Daktronics before shipment. Daktronics shall not be obligated to pay freight for any unapproved return. Purchaser shall pay any upgraded or expedited transportation charges.

D. Any replacement parts or Equipment will be new or serviceably used, comparable in function and performance to the original part or Equipment, and warranted for the remainder of the Warranty Period. Purchasing additional parts or Equipment from the Seller does not extend this Warranty Period.

E. Defects shall be defined as follows. With regard to the Equipment (excepting LEDs), a "Defect" shall refer to a material variance from the design specifications that prohibit the Equipment from operating for its intended use. With respect to LEDs, "Defects" are defined as LED pixels that cease to emit light. The limited warranty provided by Daktronics does not impose any duty or liability upon Daktronics for partial LED pixel degradation. Nor does the limited warranty provide for the replacement or installation of communication methods including but not limited to, wire, fiber optic cable, conduit, trenching, or for the purpose of overcoming local site interference radio equipment substitutions.

THIS LIMITED WARRANTY IS THE ONLY WARRANTY APPLICABLE TO THE EQUIPMENT AND REPLACES ALL OTHER WARRANTIES OR CONDITIONS, EXPRESS OR IMPLIED, INCLUDING, BUT NOT LIMITED TO, THE IMPLIED WARRANTIES OR CONDITIONS OF MERCHANTABILITY AND FITNESS FOR A PARTICULAR PURPOSE. SPECIFICALLY, EXCEPT AS PROVIDED HEREIN, THE SELLER UNDERTAKES NO RESPONSIBILITY FOR THE QUALITY OF THE EQUIPMENT OR THAT THE EQUIPMENT WILL BE FIT FOR ANY PARTICULAR PURPOSE FOR WHICH PURCHASER MAY BE BUYING THE EQUIPMENT. ANY IMPLIED WARRANTY IS LIMITED IN DURATION TO THE WARRANTY PERIOD. NO ORAL OR WRITTEN INFORMATION, OR ADVICE GIVEN BY THE COMPANY, ITS AGENTS OR EMPLOYEES, SHALL CREATE A WARRANTY OR IN ANY WAY INCREASE THE SCOPE OF THIS LIMITED WARRANTY.

THIS LIMITED WARRANTY IS NOT TRANSFERABLE.

**2. Exclusion from Warranty Coverage**

The limited warranty provided by Daktronics does not impose any duty or liability upon Daktronics for:

A. Any damage occurring, at any time, during shipment of Equipment unless otherwise provided for in the Agreement. When returning Equipment to Daktronics for repair or replacement, Purchaser assumes all risk of loss or damage, and agrees to use any shipping containers that might be provided by Daktronics and to ship the Equipment in the manner prescribed by Daktronics;

B. Any damage caused by the unauthorized adjustment, repair or service of the Equipment by anyone other than personnel of Daktronics or its authorized repair agents;



C. Damage caused by the failure to provide a continuously suitable environment, including, but not limited to: (i) neglect or misuse, (ii) a failure or sudden surge of electrical power, (iii) improper air conditioning or humidity control, or (iv) any other cause other than ordinary use;

D. Damage caused by fire, flood, earthquake, water, wind, lightning or other natural disaster, strike, inability to obtain materials or utilities, war, terrorism, civil disturbance or any other cause beyond Daktronics' reasonable control;

E. Failure to adjust, repair or replace any item of Equipment if it would be impractical for Daktronics personnel to do so because of connection of the Equipment by mechanical or electrical means to another device not supplied by Daktronics, or the existence of general environmental conditions at the site that pose a danger to Daktronics personnel;

F. Any statements made about the product by salesmen, dealers, distributors or agents, unless such statements are in a written document signed by an officer of Daktronics. Such statements as are not included in a signed writing do not constitute warranties, shall not be relied upon by Purchaser and are not part of the contract of sale;

G. Any damage arising from the use of Daktronics products in any application other than the commercial and industrial applications for which they are intended, unless, upon request, such use is specifically approved in writing by Daktronics; or

H. Any performance of preventive maintenance.

### 3. **Limitation of Liability**

Daktronics shall be under no obligation to furnish continued service under this Warranty if alterations are made to the Equipment without the prior written approval of Daktronics.

It is specifically agreed that the price of the Equipment is based upon the following limitation of liability. In no event shall Daktronics (including its subsidiaries, affiliates, officers, directors, employees, or agents) be liable for any special, consequential, incidental or exemplary damages arising out of or in any way connected with the Equipment or otherwise, including but not limited to damages for lost profits, cost of substitute or replacement equipment, down time, lost data, injury to property or any damages or sums paid by Purchaser to third parties, even if Daktronics has been advised of the possibility of such damages. The foregoing limitation of liability shall apply whether any claim is based upon principles of contract, tort or statutory duty, principles of indemnity or contribution, or otherwise.

In no event shall Daktronics be liable to Purchaser or any other party for loss, damage, or injury of any kind or nature arising out of or in connection with this Warranty in excess of the purchase price of the Equipment actually delivered to and paid for by the Purchaser. The Purchaser's remedy in any dispute under this Warranty shall be ultimately limited to the Purchase Price of the Equipment to the extent the Purchase Price has been paid.

### 4. **Assignment of Rights**

The Warranty contained herein extends only to the original end-user (which may be the Purchaser) of the Equipment and no attempt to extend the Warranty to any subsequent user-transferee of the Equipment shall be valid or enforceable without the express written consent of Daktronics.

### 5. **Dispute Resolution**

Any dispute between the parties will be resolved exclusively and finally by arbitration administered by the American Arbitration Association ("AAA") and conducted under its rules, except as otherwise provided below. The arbitration will be conducted before a single arbitrator. The arbitration shall be held in Brookings, South Dakota. Any decision rendered in such arbitration proceedings will be final and binding on each of the parties, and judgment may be entered thereon in any court of competent jurisdiction. This arbitration agreement is made pursuant to a transaction involving interstate commerce, and shall be governed by the Federal Arbitration Act.

### 6. **Governing Law**

The rights and obligations of the parties under this warranty shall not be governed by the provisions of the United Nations Convention on Contracts for the International Sales of Goods of 1980. Both parties consent to the application of the laws of the State of South Dakota to govern, interpret, and enforce all of Purchaser and Daktronics rights, duties, and obligations arising from, or relating in any manner to, the subject matter of this Warranty, without regard to conflict of law principles.

### 7. **Availability of Extended Service Agreement**

For Purchaser's protection, in addition to that afforded by the warranties set forth herein, Purchaser may purchase extended warranty services to cover the Equipment. The Extended Service Agreement, available from Daktronics, provides for electronic parts repair and/or on-site labor for an extended period from the date of expiration of this warranty. Alternatively, an Extended Service Agreement may be purchased in conjunction with this warranty for extended additional services. For further information, contact Daktronics Customer Service at 1-800-DAKTRONics (1-800-325-8766).