

Single-Section Outdoor Generation IV LED Scoreboards

Display Manual

ED-16959

Rev 3 – 14 April 2009

DAKTRONICS

Models					
BA-515	BA-2016	FB-824	MS-2012	TI-418	
BA-518	BA-2017	FB-2005		TI-2003	
BA-618	BA-2019	FB-2410	RO-2010	TI-2010	
BA-624	BA-2022		RO-2011	TI-2012	
BA-718	BA-2023	MS-915		TI-2015	
BA-1018	BA-2024	MS-918	SO-918	TI-2019	
BA-2003		MS-2002	SO-2008	TI-2024	
BA-2004	CR-2002	MS-2003	SO-2013		
BA-2005	CR-2003	MS-2004			
BA-2010		MS-2006	TI-215		
BA-2011	CT-2001	MS-2011	TI-218		
BA-2014					

Please fill in the information below for your display; use it for reference when calling Daktronics for assistance.

Display Serial No. _____

Display Model No. _____

Date Installed _____

DAKTRONICS, INC.

Copyright © 2007-09

All rights reserved. While every precaution has been taken in the preparation of this manual, the publisher assumes no responsibility for errors or omissions. No part of this book covered by the copyrights hereon may be reproduced or copied in any form or by any means – graphic, electronic, or mechanical, including photocopying, taping, or information storage and retrieval systems – without written permission of the publisher.

All Sport® and PanaView® are trademarks of Daktronics, Inc. Other trademarks used in this manual are the property of their respective owners.

Table of Contents

Section 1:	Introduction.....	1
1.1	How To Use This Manual.....	1
1.2	Daktronics Nomenclature.....	2
1.3	Manual Overview.....	3
1.4	Product Overview.....	4
1.5	Model Names.....	5
1.6	Product Safety Approval.....	5
Section 2:	Model Identification.....	7
Section 3:	Specifications.....	9
3.1	Single-Section Scoreboards.....	9
Section 4:	Component Locations.....	22
Section 5:	Schematics.....	25
Section 6:	Mechanical Installation.....	29
6.1	Scoreboard Protective Devices.....	29
6.2	Footings and Beams.....	29
6.3	Scoreboard Mounting.....	34
	Mounting Method 1.....	34
	Mounting Method 2.....	35
	Scoreboard Mounting Using Spacers.....	36
	Ad Panel Mounting.....	37
	Models BA-515-11 and BA-518-11.....	38
Section 7:	Electrical Installation.....	39
7.1	Power.....	39
	Grounding.....	40
	Power Installation.....	40
7.2	Power and Signal Connection.....	41
	Fiber Optic.....	42
	Multiple Driver Connections.....	43
Section 8:	Scoreboard Maintenance and Troubleshooting.....	45
8.1	Cabinet Specifications.....	45
8.2	Component Location and Access.....	45
	Replacing a Digit.....	46
	Replacing a Digit Segment.....	47
	Replacing a Driver.....	48

8.3	Schematic.....	48
8.4	LED Drivers	49
8.5	Segmentation and Digit Designation	50
8.6	Lightning Protection.....	50
8.7	Replacement Parts.....	51
8.8	Troubleshooting	53
8.9	Daktronics Exchange and Repair & Return Programs	54
	Exchange Program.....	54
	Before Contacting Daktronics	54
	Repair & Return Program.....	55
	Shipping Address	55
Section 9:	Team Name Message Center Maintenance	57
9.1	Team Name Message Center System Overview	57
9.2	Maintenance and Troubleshooting Overview	57
9.3	Signal Summary	58
9.4	Power Summary.....	59
9.5	Service and Diagnostics	59
	TNMC Controller.....	60
	Modules and Drivers.....	64
	Power Supplies.....	65
	Weatherstripping	66
9.6	TNMC Display Maintenance.....	66
9.7	Troubleshooting	67
9.8	Initialization Information at Startup	67
9.9	Replacement Parts List	68
Section 10:	Scoreboard Options	69
10.1	Changeable Team Name Captions	69
10.2	Trumpet Horn.....	70
	Trumpet Horn Part Numbers.....	70
10.3	Radio Control	70
10.4	Portable Power Pack	71
Appendix A:	Reference Drawings	73
Appendix B:	Eyebolts	77

List of Figures

Figure 1: Daktronics Drawing Label.....	1
Figure 2: Scoreboard ID Label.....	2
Figure 3: Lifting the Display	32
Figure 4: Clamp Mounting Method, Side View	35
Figure 5: Mounting with C-channel, Side View	36
Figure 6: Mounting with Spacers	37
Figure 7: Power Terminal Block	42
Figure 8: Signal Surge Arrestor Card.....	42
Figure 9: Driver Fiber Connection Location	42
Figure 10: LED Digit Panel.....	45
Figure 11: Digit Assembly	46
Figure 12: Segmented Digit Panel (Rear View).....	47
Figure 13: 16-column driver enclosure	48
Figure 14: Digit Designation	50
Figure 15: 8x48 Team Name Message Center	57
Figure 16: TNMC Controller Assembly.....	60
Figure 17: TNMC Internal Components (Modules Removed).....	62
Figure 18: TNMC Rear Access	63
Figure 19: TNMC Module (Rear View).....	64
Figure 20: Removing a Module.....	65

Section 1: Introduction

This manual explains the installation of **Daktronics Single-Section Outdoor LED Scoreboards** and provides details for display maintenance. With questions regarding the safety, installation, operation, or service of these systems, contact Daktronics. For more information on Daktronics Customer Service see **Section 8.9** of this manual.

1.1 How To Use This Manual

Important Safeguards:

1. Read and understand these instructions before installing the display.
2. Do not drop the control console or allow it to get wet.
3. Properly ground the scoreboard with a grounding electrode at the scoreboard location.
4. **Disconnect power when the scoreboard is not in use.**
5. **Disconnect power when servicing the scoreboard.**
6. Do not modify the scoreboard structure or attach any panels or coverings to the scoreboard without the express written consent of Daktronics, Inc.

Figure 1 illustrates the Daktronics drawing numbering system. Daktronics identifies individual engineering drawings by their drawing number (7087-P08A-69945 in the example), which is located in the lower right corner of the drawing. This manual refers to drawings by their last set of numbers and the letter preceding them. The example would be **Drawing A-69945**.

Reference drawings are grouped and inserted in alphanumeric order in the

Appendix A: Reference Drawings.

Listed below are drawing types commonly used by Daktronics, along with the information that each provides.

- **System riser diagrams:** overall system layout from control room to display, power and phase requirements
- **Shop drawings:** fan locations, transformer locations, mounting information, power and signal entrance points and access method (front or rear)
- **Schematics:** power wiring, signal wiring, panelboard or power termination panel assignments, signal termination panel assignments and transformer assignments

DAKTRONICS, INC. BROOKINGS, SD 57006		
PROJ: BASKETBALL		
TITLE: SEGMENTATION, 7 SEG BAR DIGIT		
DES. BY: BPETERSON	DRAWN BY: TNELSON	DATE: 8 JUL 02
APPR. BY: AVB	7087-P08A-69945	
SCALE: 1 = 4		

Figure 1: Daktronics Drawing Label

- **Final assembly:** component locations, part numbers, display dimensions and assembly/disassembly instructions

All references to drawing numbers, appendices, figures, or other manuals are presented in **bold** typeface, as in this example: “Refer to **Drawing A-69945** for the location of the driver enclosure.” Additionally, any drawings referenced within a particular subsection are listed at the beginning of that subsection in the following manner:

Reference Drawing:

Segmentation, 7 Seg Bar Digit..... **Drawing A-69945**

Daktronics identifies manuals by their engineering document (ED) number, which is located on the cover page of the manual. For example, this manual would be referred to as **ED-16959**.

The serial and model numbers of a Daktronics scoreboard can be found on the ID label on the display. The label will be similar to the one shown in **Figure 2**. When calling Daktronics Customer Service, please have this information available to ensure quick service. For future reference, note the scoreboard model number, serial number and installation date on the second page of this manual.

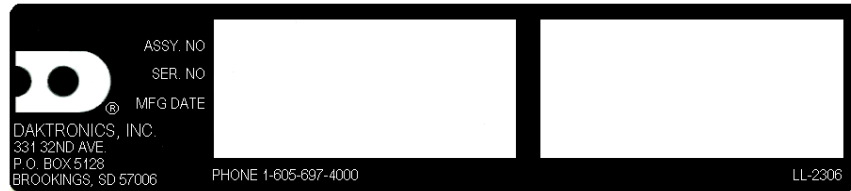

Figure 2: Scoreboard ID Label

Daktronics displays are built for long life and require little maintenance. However, from time to time, certain display components will have to be replaced. The Replacement Parts List in **Section 8.7** provides the names and part numbers of components that may require replacement during the life of this display.

Following the Replacement Parts List is an explanation of Daktronics exchange and repair and return programs. Refer to these instructions if replacing or repairing any display component.

1.2 Daktronics Nomenclature

To fully understand Daktronics drawings, it is necessary to know how various components are labeled in drawings. This information is useful when trying to communicate maintenance or troubleshooting efforts.

The label “A” on a drawing item typically denotes an assembly. An assembly can be a single circuit board or a collection of components that function together, usually mounted on a single plate or in a single enclosure.

In addition, the following labeling formats might be found on various Daktronics drawings:

- “TB _ _” denotes a termination block for power or signal cable.

- “F __” denotes a fuse.
- “E __” denotes a grounding point.
- “J __” denotes a power or signal jack.
- “P __” denotes a power or signal plug for the opposite jack.

Finally, Daktronics part numbers are commonly found on drawings. Those part numbers can be used when requesting replacement parts from Daktronics Customer Service. Take note of the following part number formats. (Not all possible formats are listed here.)

- “0P- _____ - _____” denotes an individual circuit board, such as a driver board.
- “0A- _____ - _____” denotes an assembly, such as a circuit board and the plate or bracket to which it is mounted. A collection of circuit boards working as a single unit may also carry an assembly label.
- “W- _____” denotes a wire or cable. Cables may also carry the assembly numbering format in certain circumstances. This is especially true for ribbon cables.
- “F- _____” denotes a fuse.
- “T- _____” denotes a transformer.
- “PR- _____ - _” denotes a specially ordered part.
- “M- _____” denotes a metal part, and “0S- _____” typically denotes a fabricated metal assembly.

1.3 Manual Overview

This manual details outdoor, single-section scoreboards with LED digits and characters. It is divided into the following sections:

- Section 1:** Provides an overview of the product, product safety information and labeling and numbering descriptions.
- Section 2:** Lists the drawing or drawings needed to determine scoreboard model numbers.
- Section 3:** Contains tables that show all of the mechanical specifications, circuit specifications and power requirements for each model.
- Section 4:** Lists drawings needed to determine the location of scoreboard components.
- Section 5:** Lists the electrical schematic drawing and drivers for each model.
- Section 6:** Contains mechanical installation information for each model.
- Section 7:** Contains electrical installation information for each model.
- Section 8:** Contains scoreboard service information and explains the Daktronics Exchange and Repair and Return Programs.
- Section 9:** Contains information for installation and maintenance of team name message centers (TNMCs).
- Section 10:** Contains descriptions and installation instructions for scoreboard options.
- Appendix A:** Contains all drawings referenced in this manual.
- Appendix B:** Contains [ED-7244](#), a detailed instruction on scoreboard lifting and eyebolts.

1.4 Product Overview

The Daktronics outdoor LED scoreboards are part of a family of scoring and timing displays designed to offer easy installation, readability and reliability. Microprocessor control assures consistent operation and accuracy.

Featuring large, highly visible PanaView® digits 10" to 60" tall, the boards use light emitting diodes, or LEDs, to illuminate the display. LEDs are tiny, solid-state components that use a semiconductor chip to transform electrical current into light; they are high-intensity, low-energy lighting units. Scoreboards in this series typically use red or amber LEDs for optimum outdoor readability.

Because of their LED technology, the scoreboards consume little power – barely more than a single household lamp. Power usage for displays in this series ranges from 150 W to a maximum of 1500 W.

Each of the sections in this manual contains model-specific information, including physical dimensions, digit configuration and power requirements. The scoreboard engineering drawings, located in **Appendix A**, also list dimensions, weight and mounting instructions for each display. Additionally, the scoreboard model number and electrical requirements can be found on a label on the scoreboard entrance panel.

Cabinets for the displays are constructed of heavy-gauge aluminum. Digit and indicator faceplates are black and are set directly into the scoreboard surface. Permanent captions and optional striping are white vinyl.

Note: Some drawings and text in this manual refer to team name message centers or TNMCs. Team name message centers are scoreboard-mounted, matrix LED units which electronically display home and guest team names.

TNMCs are available as a standard scoreboard option with several of the models in this series, and the message centers are also available for retrofit on existing scoreboards. **Section 9** of this manual offers step-by-step information on TNMC maintenance and troubleshooting.

The outdoor LED scoreboards are designed for use with the All Sport® 5000 series control console. Both consoles use All Sport keyboard overlays (sport inserts) for game control, and the boards operate without modification on All Sport 5000 signal protocol. Refer to the following controller manuals for operating instructions:

- [ED-11976](#): All Sport 5000 Series Control Console Operation Manual

1.5 Model Names

Reference Drawings:

Single-Section LED Scoreboard Models	Drawing A-142912
Single-Section LED Scoreboard Models	Drawing A-152950

Daktronics scoreboards are differentiated by their model numbers: *BA-1018*, for example, designates a specific baseball scoreboard. The two-letter prefixes for scoreboards in this manual include the following: **BA** – baseball; **CR** – cricket; **FB** – football; **MS** – multisport; **RO** – rodeo; **SO** – soccer; and **TI** – timer.

Most Daktronics scoreboards carry a two-number suffix that refers to indoor-outdoor status, power supply and digit color: -11 are outdoor scoreboards, 120 V, and feature red digits; -21 are outdoor scoreboards, 120 V, and feature amber digits.

1.6 Product Safety Approval

Daktronics outdoor scoreboards are ETL listed and tested to CSA standard for outdoor use. Contact Daktronics with any questions regarding testing procedures.

Section 2: Model Identification

Use the following drawings to determine the model number of your scoreboard. The drawings listed here are located in **Appendix A: Reference Drawings**; where they are inserted in alphanumeric order by drawing number.

Reference Drawings:

Single-Section LED Scoreboard Models	Drawing A-142912
Single-Section LED Scoreboard Models	Drawing A-152950

Note: Not all models are listed in these two drawings.

Section 3: Specifications

The table on the following pages shows all of the mechanical specifications, circuit specifications and maximum power requirements for each model in this manual. Models are listed in alphanumeric order.

3.1 Single-Section Scoreboards

Notes: Driver address setting can be configured using the J19 address plug. Also, the S1 dip switch is found in all Gen IV drivers. For more details see **Section 8.4**.

Signal wires must be a minimum of 22 AWG with shield. Daktronics recommends using W-1234 or W-1614. Models with an –11 or –12 suffix feature red digits and indicators; suffixes –21 and –22 indicate amber digits.

Model	Dimensions Height, Width, Depth	Weight	Digit Size Digit Color	Maximum Wattage	Power	Amps per Line (Single Phase)	Driver Number and Address
		Uncrated Crated					
BA-515-11/21	H3'-0", W6'-0", D6" (914 mm, 1829 mm, 152 mm)	92 lb (42 kg) 175 lb (79 kg)	15" (381 mm) -11: red -21: amber	150 W	120 V AC	1.3 A	A1 61
BA-518-11/21	H4'-0", W9'-0", D6" (1219 mm, 2743 mm, 152 mm)	96 lb (44 kg) 182 lb (83 kg)	18" (457 mm) -11: red -21: amber	150 W	120 V AC	1.3 A	A1 61

Model	Dimensions Height, Width, Depth	Weight	Digit Size Digit Color	Maximum Wattage	Power	Amps per Line (Single Phase)	Driver Number and Address
		Uncrated Crated					
BA-518-12/22	H4'-0", W9'-0", D6" (1219 mm, 2743 mm, 152 mm)	96 lb (44 kg) 182 lb (83 kg)	18" (457 mm) -11: red -21: amber	150 W	240 V AC	.65 A	A1 61
BA-618-11/21	H5'-0", W14'-0", D6" (1524 mm, 4267 mm, 152 mm)	200 lb (91 kg) 380 lb (172 kg)	18" (457 mm) -11: red -21: amber	150 W	120 V AC	1.3 A	A1 61
BA-624-11/21	H6'-0", W16'-0", D6" (1829 mm, 4877 mm, 152 mm)	300 lb (136 kg) 570 lb (259 kg)	24" (610 mm) -11: red -21: amber	150 W	120 V AC	1.3 A	A1 61
BA-718-11/21	H4'-0", W12'-0", D6" (1219 mm, 3658 mm, 152 mm)	128 lb (58 kg) 243 lb (110 kg)	18" (457 mm) -11: red -21: amber	150 W	120 V AC	1.3 A	A1 62
BA-1018-11/21	H6'-0", W14'-0", D6" (1829 mm, 4267 mm, 152 mm)	216 lb (98 kg) 410 lb (186 kg)	18" (457 mm) -11: red -21: amber	300 W	120 V AC	2.5 A	A1 12
BA-2003-11/21	H4'-6", W10'-0", D8" (1372 mm, 3048 mm, 203 mm)	200 lb (91 kg) 380 lb (172 kg)	36" (914 mm) -11: red -21: amber	150 W	120 V AC	1.3 A	A1 11

Model	Dimensions Height, Width, Depth	Weight	Digit Size Digit Color	Maximum Wattage	Power	Amps per Line (Single Phase)	Driver Number and Address
		Uncrated Crated					
BA-2004-11/21	H6'-6", W20'-0", D6" (1981 mm, 6096 mm, 152 mm)	600 lb (272 kg) 1,140 lb (517 kg)	<ul style="list-style-type: none"> ▪ Time, ball, strike, out: 18" (457 mm) ▪ Inning, runs: 15" (381 mm) -11: red -21: amber	900 W	120 V AC	7.5 A	A1 67 A2 68 A3 69
BA-2004-11/21 w/TNMC	H6'-6", W20'-0", D6" (1981 mm, 6096 mm, 152 mm)	720 lb (327 kg) 1,368 lb (621 kg)	<ul style="list-style-type: none"> ▪ Time, ball, strike, out: 18" (457 mm) ▪ Inning, runs: 15" (381 mm) -11: red -21: amber	1100 W (w/red TNMC) 1200 W (w/amber TNMC)	120 V AC	9.2 A 10.0 A	A1 67 A2 68 A3 69
BA-2005-11/21	H6'-6", W20'-0", D6" (1981 mm, 6096 mm, 152 mm)	600 lb (272 kg) 1,140 lb (517 kg)	<ul style="list-style-type: none"> ▪ Time, ball, strike out: 18" (457 mm) ▪ Inning, runs: 15" (381 mm) -11: red -21: amber	900 W	120 V AC	7.5 A	A1 67 A2 68 A3 69
BA-2005-11/21 w/TNMC	H6'-6", W20'-0", D6" (1981 mm, 6096 mm, 152 mm)	680 lb (08 kg) 1292 lb (586 kg)	<ul style="list-style-type: none"> ▪ Time, ball, strike, out: 18" (457 mm) ▪ Inning, runs: 15" (381 mm) -11: red -21: amber	1100 W (w/red TNMC) 1200 W (w/amber TNMC)	120 V AC	9.2 A 10.0 A	A1 67 A2 68 A3 69

Model	Dimensions Height, Width, Depth	Weight	Digit Size Digit Color	Maximum Wattage	Power	Amps per Line (Single Phase)	Driver Number and Address
		Uncrated Crated					
BA-2010-11/21	H6'-0", W8'-0", D6" (1829 mm, 2438 mm, 152 mm)	180 lb (82 kg) 342 lb (155 kg)	<ul style="list-style-type: none"> ▪ Digits: 18" (457 mm) ▪ H/E indicators: circular -11: red -21: amber 	300 W	120 V AC	2.5 A	A1 61
BA-2011-11/21	H6'-6", W20'-0", D6" (1981 mm, 6096 mm, 152 mm)	620 lb (281 kg) 1,178 lb (534 kg)	<ul style="list-style-type: none"> ▪ Time, ball, strike, out: 18" (457 mm) ▪ Inning, runs: 15" (381 mm) -11: red -21: amber 	1200 W	120 V AC	10.0 A	A1 67 A2 68 A3 69 A4 11
BA-2011-11/21 w/TNMC	H6'-6", W20'-0", D6" (1981 mm, 6096 mm, 152 mm)	720 lb (327 kg) 1368 lb (621 kg)	<ul style="list-style-type: none"> ▪ Time, ball, strike, out: 18" (457 mm) ▪ Inning, runs: 15" (381 mm) -11: red -21: amber 	1100 W (w/red TNMC) 1500 W (w/amber TNMC)	120 V AC	9.2 A 12.5 A	A1 67 A2 68 A3 69 A4 11
BA-2014-11/21	H6'-6", W20'-0", D6" (1981 mm, 6096 mm, 152 mm)	600 lb (272 kg) 1,140 lb (517 kg)	<ul style="list-style-type: none"> ▪ Ball, strike, out, H/E: 18" (457 mm) ▪ Inning, runs, hits, errors: 15" (381 mm) -11: red -21: amber 	900 W	120 V AC	7.5 A	A1 67 A2 68 A3 69

Model	Dimensions Height, Width, Depth	Weight Uncrated Crated	Digit Size Digit Color	Maximum Wattage	Power	Amps per Line (Single Phase)	Driver Number and Address
BA-2016-11/21	H6'-0", W14'-0", D6" (1829 mm, 4267 mm, 152 mm)	216 lb (98 kg) 410 lb (186 kg)	<ul style="list-style-type: none"> ▪ SOP, ball, strike, out ▪ Inning, runs: 18" (457 mm) -11: red -21: amber	600 W	120 V AC	5.0 A	A1 12 A2 11
BA-2017-11/21	H6'-0", W14'-0", D6" (1829 mm, 4267 mm, 152 mm)	216 lb (98 kg) 410 lb (186 kg)	<ul style="list-style-type: none"> ▪ Time, ball, strike, out ▪ Inning, runs: 18" (457 mm) -11: red -21: amber	300 W	120 V AC	5.0 A	A1 61
BA-2019-11/21	H6'-0", W20'-0", D6" (1829 mm, 6096 mm, 152 mm)	500 lb (227 kg) 950 lb (431 kg)	<ul style="list-style-type: none"> ▪ Time, ball, strike out: 15" (457 mm) ▪ Inning, runs: 10" (381 mm) -11: red -21: amber	900 W	120 V AC	7.5 A	A1 67 A2 68 A3 69
BA-2019-11/21 w/TNMC	H6'-0", W20'-0", D6" (1829 mm, 6096 mm, 152 mm)	580 lb (263 kg) 1102 lb (2094 kg)	<ul style="list-style-type: none"> ▪ Time, ball, strike out: 15" (457 mm) ▪ Inning, runs: 10" (381 mm) -11: red -21: amber	1100 W (w/red TNMC) 1200 W (w/amber TNMC)	120 V AC	9.2 A 10.0 A	A1 67 A2 68 A3 69

Model	Dimensions Height, Width, Depth	Weight	Digit Size Digit Color	Maximum Wattage	Power	Amps per Line (Single Phase)	Driver Number and Address	
		Uncrated						
BA-2022-11/21	H7'-0", W16'-0", D6" (2134 mm, 4877 mm, 152 mm)	275 lb (125 kg)	15" (381 mm)	600 W	120 V AC	5.0 A	A1	64
		500 lb (2274 kg)	-11: red -21: amber				A2	701
BA-2023-11/21	H2'-0", W9'-0", D6" (609 mm, 2743 mm, 152 mm)	50 lb (23 kg)	■ PITCH COUNT 15" (381 mm)	150 W	120 V AC	1.3 A	A1	3
		85 lb (39 kg)	-11: red -21: amber					
BA-2024-11/21	H1'-6", W2'-0", D6" (457 mm, 610 mm, 152 mm)	15 lb (7 kg)	15" (381 mm)	150 W	120 V AC	1.3 A	A1	2
		29 lb (13 kg)	-11: red -21: amber					
CR-2002-11/21	H5'-7", W5'-7", D6" (1702 mm, 1702 mm, 152 mm)	200 lb (91 kg)	15" (381 mm)	300 W	120 V AC	2.5 A	A1	12
		380 lb (172 kg)	-11: red -21: amber					
CR-2003-11/21	H6'-9", W10'-0", D6" (2058 mm, 3048 mm, 152 mm)	250 lb (113 kg)	15" (381 mm)	600 W	120 V AC	5.0 A	A1	12
		475 lb (216 kg)	-11: red -21: amber				A2	13

Model	Dimensions Height, Width, Depth	Weight	Digit Size Digit Color	Maximum Wattage	Power	Amps per Line (Single Phase)	Driver Number and Address
		Uncrated Crated					
CT-2001-11/21	H2'-0", W6'-0", D6" (610 mm, 1829 mm, 152 mm)	40 lb (18 kg) 76 lb (34 kg)	18" (457 mm) -11: red -21: amber	150 W	120 V AC	1.3A	A1 1
FB-824-11/21	H4'-0", W14'-0", D6" (1219 mm, 4267 mm, 152 mm)	200 lb (91 kg) 380 lb (172 kg)	24" (610 mm) -11: red -21: amber	300 W	120 V AC	2.5 A	A1 11
FB-2005-11/21	H5'-0", W10'-0", D6" (1524 mm, 3048 mm, 152 mm)	180 lb (82 kg) 342 lb (155 kg)	18" (457 mm) -11: red -21: amber	300 W	120 V AC	2.5 A	A1 11
FB-2410-11/21	H8'-0", W20'-0", D8" (2438 mm, 6096 mm, 203 mm)	600 lb (272 kg) 1200 lb (544 kg)	60" (1524 mm) -11: red -21: amber	1000 W	120 V AC	8.5 A	A1 1
MS-915-11/21	H4'-0", W8'-0", D6" (1219 mm, 2438 mm, 279 mm)	88 lb (40 kg) 167 lb (76 kg)	15" (381 mm) -11: red -21: amber	300 W	120 V AC	2.5 A	A1 11

Model	Dimensions Height, Width, Depth	Weight Uncrated Crated	Digit Size Digit Color	Maximum Wattage	Power	Amps per Line (Single Phase)	Driver Number and Address
MS-918-11/21	H5'-0", W14'-0", D6" (1524 mm, 4267 mm, 152 mm)	220 lb (100 kg) 418 lb (190kg)	<ul style="list-style-type: none"> ▪ Clock, scores: 18" (457 mm) ▪ Inning: 15" (381 mm) -11: red -21: amber	300 W	120 V AC	2.5 A	A1 11
MS-2002-11/21	H4'-6", W16'-0", D6" (1372 mm, 4877 mm, 152 mm)	200 lb (91 kg) 380 lb (172 kg)	24" (610 mm) -11: red -21: amber	300 W	120 V AC	2.5 A	A1 11
MS-2002-11/21 w/TNMC	H4'-6", W16'-0", D6" (1372 mm, 4877 mm, 152 mm)	320 lb (145 kg) 608 lb (276 kg)	24" (610 mm) -11: red -21: amber	500 W (w/red TNMC) 600 W (w/amber TNMC)	120 V AC	4.2 A 5.0 A	A1 11
MS-2003-11/21	H4'-0", W15'-0", D6" (1219 mm, 4572 mm, 152 mm)	175 lb (80 kg) 332 lb (151 kg)	18" (457 mm) -11: red -21: amber	300 W	120 V AC	2.5 A	A1 11

Model	Dimensions Height, Width, Depth	Weight	Digit Size Digit Color	Maximum Wattage	Power	Amps per Line (Single Phase)	Driver Number and Address
		Uncrated Crated					
MS-2003-11/21 W/TNMC	H4'-0", W15'-0", D6" (1219 mm, 4572 mm, 152 mm)	295 lb (134 kg) 561 lb (254 kg)	18" (457 mm) -11: red -21: amber	500 W (w/red TNMC) 600 W (w/amber TNMC)	120 V AC	4.2 A 5.0 A	A1 11
MS-2004-11/21	H5'-0", W18'-0", D6" (1524 mm, 5486 mm, 152 mm)	300 lb (136 kg) 570 lb (259 kg)	18" (457 mm) -11: red -21: amber	600 W	120 V AC	5.0 A	A1 74 A1 75
MS-2006-11/21	H7'-0", W25'-0", D8" (2134 mm, 7620 mm, 203 mm)	560 lb (254 kg) 1,064 lb (483 kg)	<ul style="list-style-type: none"> ▪ Clock, scores: 30" (762 mm) ▪ Period: 24" (610 mm) -11: red -21: amber	300 W	120 V AC	2.5 A	A1 11
MS-2006-11/21 w/TNMC	H7'-0", W25'-0", D8" (2134 mm, 7620 mm, 203 mm)	680 lb (308 kg) 1,292 lb (586 kg)	<ul style="list-style-type: none"> ▪ Clock, scores: 30" (762 mm) ▪ Period: 24" (610 mm) -11: red -21: amber	500 W (w/red TNMC) 900 W (w/amber TNMC)	120 V AC	47.5 A	A1 11

Model	Dimensions Height, Width, Depth	Weight Uncrated Crated	Digit Size Digit Color	Maximum Wattage	Power	Amps per Line (Single Phase)	Driver Number and Address
MS-2011-11/21	H4'-6", W20'-0", D6" (1372 mm, 6096 mm, 152 mm)	208 lb (129 kg) 532 lb (241 kg)	<ul style="list-style-type: none"> ▪ Clock, scores: 24" (10 mm) ▪ Period: 18" (457 mm) -11: red -21: amber	300 W	120 V AC	2.5 A	A1 11
MS-2011-11/21 w/TNMC	H4'-6", W20'-0", D6" (1372 mm, 6096 mm, 152 mm)	400 lb (181 kg) 760 lb (345 kg)	<ul style="list-style-type: none"> ▪ Clock, scores: 24" (610 mm) ▪ Period: 18" (457 mm) -11: red -21: amber	500 W (w/red TNMC) 600 W (w/amber TNMC)	120 V AC	4.2 A 5.0 A	A1 11
MS-2012-11/21	H5'-0", W25'-0", D6" (1524 mm, 7620 mm, 152 mm)	400 lb (181 kg) 760 lb (345 kg)	18" (457 mm) -11: red -21: amber	600 W	120 V AC	5.0 A	A1 74 A1 75
RO-2010-11/21	H2'-7", W9'-0", D6" (787 mm, 2743 mm, 152 mm)	200 lb (91 kg) 380 lb (172 kg)	24" (610 mm) -11: red -21: amber	150 W	120 V AC	1.25 A	A1 12

Model	Dimensions Height, Width, Depth	Weight	Digit Size Digit Color	Maximum Wattage	Power	Amps per Line (Single Phase)	Driver Number and Address
		Uncrated					
RO-2011-11/21	H2'-0", W6'-0", D6" (610 mm, 1828 mm, 152 mm)	80 lb (18 kg)	18", (457 mm)	150 W	120 V AC	1.25 A	A1 12
		152 lb (69 kg)	-11: red -21: amber				
SO-918-11/21	H4'-0", W12'-0", D6" (1219 mm, 3658 mm, 152 mm)	180 lb (82 kg)	18" (457 mm)	300 W	120 V AC	2.5 A	A1 11
		156 lb (71 kg)	-11: red -21: amber				
SO-2008-11/21	H5'-6", W16'-0", D6" (1676 mm, 4877 mm, 152 mm)	240 lb (109 kg)	18" (457 mm)	300 W	120 V AC	2.5 A	A1 17
		456 lb (207 kg)	-11: red -21: amber				
SO-2008-11/21 w/TNMC	H5'-6", W16'-0", D6" (1676 mm, 4877 mm, 152 mm)	240 lb (109 kg)	18" (457 mm)	500 W (w/red TNMC)	120 V AC	4.2 A	A1 17
		456 lb (207 kg)	-11: red -21: amber	600 W (w/amber TNMC)		5.0 A	

Model	Dimensions Height, Width, Depth	Weight Uncrated Crated	Digit Size Digit Color	Maximum Wattage	Power	Amps per Line (Single Phase)	Driver Number and Address
SO-2013-11/21	H6'-0", W16'-0", D6" (1829 mm, 4877 mm, 152 mm)	450 lb (204 kg) 825 lb (374 kg)	<ul style="list-style-type: none"> ▪ Clock: 24" (610 mm) ▪ Scores/Stats: 18" (457 mm) -11: red -21: amber	600 W	120 VAC	5.0	A1 13 A2 14
TI-215-11/21	H1'-6", W2'-0", D6" (457 mm, 610 mm, 152 mm)	15 lb (7 kg) 29 lb (13 kg)	<ul style="list-style-type: none"> ▪ 15" (381 mm) -11: red -21: amber	150 W	120 V AC	1.3 A	A1 2
TI-218-11/21	H2'-0", W3'-0", D6" (610 mm, 914 mm, 152 mm)	16 lb (7 kg) 53 lb (24 kg)	18" (457 mm) -11: red -21: amber	150 W	120 V AC	1.3 A	A1 2
TI-418-11/21	H2'-0", W6'-0", D6" (610 mm, 1829 mm, 152 mm)	40 lb (18 kg) 76 lb (34 kg)	18" (457 mm) -11: red -21: amber	150 W	120 V AC	1.25 A	A1 1
TI-2003-11/21	H3'-0", W4'-0", D6" (914 mm, 1219 mm, 152 mm)	65 lb (29 kg) 124 lb (56 kg)	30" (762 mm) -11: red -21: amber	150 W	120 V AC	1.25 A	A1 2

Model	Dimensions Height, Width, Depth	Weight	Digit Size Digit Color	Maximum Wattage	Power	Amps per Line (Single Phase)	Driver Number and Address
		Uncrated Crated					
TI-2010-11/21	H2'-0", W3'-0", D6" (610 mm, 914 mm, 152 mm)	30 lb (14 kg) 57 lb (26 kg)	18" (457 mm) -11: red -21: amber	150 W	120 V AC	1.25 A	A1 2
TI-2012-11/21	H3'-6", W5'-0", D6" (1067 mm, 1524 mm, 152 mm)	130 lb (59 kg) 247 lb (112 kg)	<ul style="list-style-type: none"> ▪ Clock: 15" (381 mm) ▪ All other 18" (457 mm) -11: red -21: amber	150 W	120 V AC	1.25 A	A1 1
TI-2015-11/21	H2'-4", W3'-4", D6" (711 mm, 1016 mm, 152 mm)	36 lb (16 kg)	24" (610 mm) -11: red -21: amber	150 W	120 V AC	1.25 A	A1 2
TI-2019-11/21	H2'-0", W6'-0", D6" (610 mm, 1829 mm, 152mm)	40 lb (18 kg) 77 lb (35 kg)	18" (457 mm) -11: red -21: amber	150 W	120 V AC	1.25 A	A1 1
TI-2024-11/21	H4'-6", W6'-0", D8" (1219 mm, 1829 mm, 203 mm)	140 lb (64 kg) 260 lb (118 kg)	36" (914 mm) -11: red -21: amber	300 W	120 V AC	2.5 A	A1 2

Section 4: Component Locations

Use the following drawings to determine the location of scoreboard components. The drawings are listed below by model number; they are located in **Appendix A: Reference Drawings**, where they are inserted in alphanumeric order by drawing number.

Model	Drawing Title	Drawing
BA-515	Component Locations; BA-515-11/-21,	A-178600
BA-518	Component Locations; BA-518-11/-21	A-178696
BA-618	Component Locations; BA-618-11/-21	A-227949
BA-624	Component Locations; BA-624-11/-21	A-227767
BA-718	Component Locations; BA-718-11/-21	A-178784
BA-1018	Component Locations; BA-1018-11/-21	A-227184
BA-2003	Component Locations, BA-2003-11/-21	A-180362
BA-2004	Component Locations; BA-2004-11/-21	A-228668
BA-2004 TNMC	Component Locations; BA-2004-11/-21	A-228668
BA-2005	Component Locations; BA-2005-11/-21	A-234592
BA-2005 TNMC	Component Locations; BA-2005-11/-21	A-234592
BA-2010	Component Locations, BA-2010-11/-21	A-237102
BA-2011	Component Locations, BA-2011-11/-21	A-237108
BA-2011 TNMC	Component Locations, BA-2011-11/-21	A-237108
BA-2014	Component Locations, BA-2014-11/-21	A-237118
BA-2016	Component Locations, BA-2016-11/-21	A-237124
BA-2017	Component Locations, BA-2017-11/21	A-239729
BA-2019	Component Locations, BA-2019-11/2	A-260481
BA-2019 TNMC	Component Locations, BA-2019-11/2	A-260481
BA-2022	Component Locations, BA-2022-11/21	A-329456
BA-2023	Component Location: BA-2023	A-331219

Model	Drawing Title	Drawing
BA-2024	Component Location: BA-2024	A-825868
CR-2002	Component Locations; CR-2002-11/21	A-235279
CR-2003	Component Locations; CR-2003-11/21	A-248722
CT-2001	Component Locations; CT-2001-11/-21, G4	A-578903
FB-824	Component Locations; FB-824-11/-21	A-182543
FB-2005	Component Locations; FB-2005-11/-21	A-228192
FB-2410	Component Locations; FB-2410-11/21	A-274863
MS-915	Component Locations; MS-915-11/-21	A-180365
MS-918	Component Locations; MS-918-11/-21	A-227840
MS-2002	Component Locations; MS-2002-11/-21	A-235932
MS-2002 TNMC	Component Locations; MS-2002-11/-21	A-235932
MS-2003	Component Locations; MS-2003-11/-21	A-189593
MS-2003 TNMC	Component Locations; MS-2003-11/-21	A-189593
MS-2004	Component Locations; MS-2004-11/-21	A-229758
MS-2006	Component Locations; MS-2006-11/-21	A-189213
MS-2006 TNMC	Component Locations; MS-2006-11/-21	A-189213
MS-2011	Component Locations; MS-2011-11/-21	A-229459
MS-2011 TNMC	Component Locations; MS-2011-11/-21	A-193823
MS-2012	Component Locations; MS-2012-11/-21	A-246786
RO-2010	Component Locations; RO-2010-11/-21	A-182293
RO-2011	Component Locations; RO-2011-11/-21	A-182296

Model	Drawing Title	Drawing
SO-918	Component Locations; SO-918-11/-21	A-180835
SO-2008	Component Locations, SO-2008-11/-21	A-236233
SO-2008 TNMC	Component Locations, SO-2008-11/-21	A-236233
SO-2013	Component Locations; SO-2013-11/-21	A-228598
TI-215	Component Locations, TI-215-11/-21	A-201607
TI-218	Component Locations; TI-218-11/-21	A-181701
TI-418	Component Locations; TI-418-11/-21	A-181177
TI-2003	Component Locations; TI-2003-11/-21	A-182702
TI-2010	Component Locations; TI-2010-11/-21	A-182110
TI-2012	Component Locations; TI-2012-11/-21	A-182081
TI-2015	Component Locations; TI-2015-11/-21	A-182176
TI-2019	Component Locations; TI-2019-11/-21	A-182090
TI-2024	Component Locations; TI-2024-11/21	A-236131

Section 5: Schematics

Reference Drawings:

Schematic, Multipurpose LED Driver	Drawing A-165028
Schematic; Gen III & IV, OD LED, 3 Drvr Display	Drawing A-179541
Schematic; Gen III & IV, OD LED, 1 Drv w/TNMC	Drawing A-179790
Schematic; Gen III & IV, OD LED, 3 Drv w/TNMC	Drawing A-180081
Schematic; Gen III & IV, O.D. LED, 2 Drvr Display	Drawing A-180637
Driver; Gen IV Outdoor LED, 16 Col Master	Drawing A-284920
Driver; Gen IV Outdoor LED, 8 Col Master	Drawing A-284922
Schematic; Gen IV Outdoor LED, 16 Column Drvr	Drawing A-285779
Schematic, Gen IV Outdoor Driver, 8 Column Driver	Drawing A-285881
Schematic; 240 GEN IV Outdoor LED, 16 COL Driver.....	Drawing A-324504
Component Location; BA-2022-11/-21, G4	Drawing A-329456
Enclosed Driver; 4-Col MASC.....	Drawing B-179349
Schematic; Baseball w/S.O.P. GEN IV, Optional TNMC	Drawing B-204725
Schematic; GEN III & IV OD LED, 1 DRVR W/S.O.P.....	Drawing B-210454

Use the following table to determine the correct driver and schematic for your scoreboard model. Individual 8- and 16-column drivers are illustrated in **Drawings A-284920** and **A-285881**. Wiring diagrams for both drivers, in master and slave configurations, are shown on the schematics, **Drawings A-285779, A-285881, A-179541, A-179790, A-180081, A-180637, A-324504, and B-210454.**

Model	Driver	Driver Drawing	Schematic Drawing
BA-515	8-column driver	A-284922	A-285881
BA-518	8-column driver	A-284922	A-285881 A-324504 for 240 V AC model
BA-618	8-column driver	A-284922	A-285881
BA-624	8-column driver	A-284922	A-285881
BA-718	8-column driver	A-284922	A-285881
BA-1018	16-column driver	A-284920	A-285779
BA-2003	8-column driver	A-284922	A-285881
BA-2004	16-column driver/slaves	A-284920	A-179541
BA-2004 TNMC	16-column driver/slaves	A-284920	A-180081
BA-2005	16-column driver/slaves	A-284920	A-179541
BA-2005 TNMC	16-column driver/slaves	A-284920	A-180081
BA-2010	16-column driver	A-284920	A-285779
BA-2011	16-column driver/slaves	A-284920	B-204264
BA-2011 TNMC	16-column driver/slaves	A-284920	B-204264
BA-2014	16-column driver/slaves	A-284920	A-179541

Model	Driver	Driver Drawing	Schematic Drawing
BA-2016	16-column driver/SOP	A-284920	B-210454
BA-2017	16-column driver	A-284920	A-285779
BA-2019	16 column driver/slaves	A-284920	A-179541
BA-2019 TNMC	16 column driver/slaves	A-284920	A-180081
BA-2022	16 column driver/slaves	A-284920	A-180637
BA-2023	16 column driver	A-284920	A-285779
BA-2024	4 column MASC driver	B-179349	A-165028
CR-2002	16 column driver	A-284920	A-285779
CR-2003	16 column driver	A-284920	A-180637
CT-2001	8 column driver	A-248922	A-285881
FB-824	16-column driver	A-284920	A-285779
FB-2005	16-column driver	A-284920	A-285779
FB-2410	16-column driver	A-284920	A-285779
MS-915	16-column driver	A-284920	A-285779
MS-918	16-column driver	A-284920	A-285779
MS-2002	16-column driver	A-284920	A-285779
MS-2002 TNMC	16-column driver	A-284920	A-179790
MS-2003	16-column driver	A-284920	A-285779
MS-2003 TNMC	16-column driver	A-284920	A-179790
MS-2004	16-column driver	A-284920	A-180637
MS-2006	16-column driver	A-284920	A-285779
MS-2006 TNMC	16-column driver	A-284920	A-179790
MS-2011	16-column driver	A-284920	A-285779
MS-2011 TNMC	16-column driver	A-284920	A-179790
MS-2012	16-column driver	A-284920	A-180637
RO-2010	8-column driver	A-284922	A-285881
RO-2011	8-column driver	A-284922	A-285881

Model	Driver	Driver Drawing	Schematic Drawing
SO-918	16-column driver	A-284920	A-285779
SO-2008	16-column driver	A-284920	A-285779
SO-2008 TNMC	16-column driver	A-284920	A-179790
SO-2013	16-column driver	A-284920	A-285779
TI-215	4-column MASC driver	B-179349	A-165028
TI-218	8-column driver	A-284922	A-285881
TI-2010	8-column driver	A-284922	A-285881
TI-2012	8-column driver	A-284922	A-285881
TI-2015	8-column driver	A-284922	A-285881
TI-2019	8-column driver	A-284922	A-285881
TI-2024	16-column driver	A-284920	A-285779

Section 6: Mechanical Installation

Mechanical installation consists of installing concrete footing and steel beams, mounting the scoreboard and accompanying ad panels to the beams.

6.1 Scoreboard Protective Devices

Daktronics makes available optional devices, including screens and netting, to help protect the scoreboard from damage due to normal ball impacts.

Note: Some users install devices to protect the scoreboard from projectiles. Scoreboard protection devices not provided by Daktronics must be approved by Daktronics prior to installation. Failure to follow this approval procedure will void the scoreboard warranty.

6.2 Footings and Beams

Use the following drawings to determine the correct installation drawing for your scoreboard. The drawings are listed below by model number; they are located in **Appendix A: Reference Drawings**, where they are inserted in alphanumeric order by drawing number.

Model	Drawing Title	Drawing
BA-515	Installation Specifications, BA-515	A-55003
BA-518	Installation Specifications, BA-518	A-55004
BA-518 w/ 2 ad panels	Installation Specifications, BA-518 w/ 2 ads	A-211376
BA-618	Installation Specifications, BA-618	A-55006
BA-624	Installation Specifications, BA-624/SO-2013	A-55007
BA-718	Installation Specifications, BA-718	A-55005
BA-1018	Installation Specifications, BA-1018	A-61904
BA-2003	Installation Specifications, BA-2003	A-158322
BA-2004	Installation Specifications; BA-2004/2005/2011/2014	A-152777
BA-2004 TNMC	Installation Specifications; BA-2004/2005/2011/2014	A-152777
BA-2005	Installation Specifications; BA-2004/2005/2011/2014	A-152777
BA-2005 TNMC	Installation Specifications; BA-2004/2005/2011/2014	A-152777
BA-2010	Installation Specifications, BA-2010-11	A-179304
BA-2011	Installation Specifications; BA-2004/2005/2011/2014	A-152777

Model	Drawing Title	Drawing
BA-2011 TNMC	Installation Specifications; BA-2004/2005/2011/2014	A-152777
BA-2014	Installation Specifications; BA-2004/2005/2011/2014	A-152777
BA-2016	Installation Specifications; BA-2016	A-61904
BA-2017	Installation Specifications; BA-2017	A-61904
BA-2019	Installation Specifications; BA-2019-11/21	A-233487
BA-2019 TNMC	Installation Specifications; BA-2019-11/21	A-233487
BA-2022	Installation Specifications; BA-20-11/21	TBD
BA-2023	TBD	TBD
BA-2024	Installation Specifications; TI-215/BA-2024	A-201655
CR-2002	Installations Specifications CR-2002	A-235517
CR-2003	Installations Specifications CR-2003	A-248966
CT-2001	Installation Specs; TI-418/RO-2011/CT- 2001/TI-2019	A-169380
FB-824	Installation Specifications, FB-824 & SO-824	A-127287
FB-2005	Installation Specifications; FB-2005-11	A-162886
FB-2410	Installation Specifications; FB-2410-11	Pending
MS-915	Installation Specifications, MS-915	A-113568
MS-918	Installation Specifications, MS-918	A-55009
MS-2002	Installation Specifications, MS-2002	A-127195
MS-2002 TNMC	Installation Specifications, MS-2002	A-127195
MS-2003	Installation Specifications; MS-2003	A-191730
MS-2003 TNMC	Installation Specifications; MS-2003	A-191730
MS 2004	Installation Specifications, MS-2004	A-176286
MS-2006	Installation Specifications, MS-2006	A-135575
MS-2006 TNMC	Installation Specifications, MS-2006	A-135575
MS-2011	Installation Specifications, MS-2011	A-135414
MS-2011 TNMC	Installation Specifications, MS-2011	A-135414

Model	Drawing Title	Drawing
MS-2012	Installation Specifications; MS-2012	A-152790
RO-2010	Installation Specs; RO-2010	A-185216
RO-2011	Installation Specs; TI-418/RO-2011/ CT-2001/TI-2019	A-169380
SO-918	Installation Specifications, SO-918, SO-2009, SO-2010	A-55010
SO-2008	Installation Specifications, SO-2008	A-149074
SO-2008 TNMC	Installation Specifications, SO-2008	A-149074
SO-2013	Installation Specifications, BA-624/SO-2013	A-55007
TI-215	Installation Specifications, TI-215	A-201655
TI-218	Installation Specifications, TI-218	A-169376
TI-418	Installation Specs; TI-418/RO-2011/ CT-2001/TI-2019	A-169380
TI-2003	Installation Specifications, TI-2003	A-169367
TI-2010*	Installation Specifications; RO-2010 (may be used for TI-2010)	A-185216
TI-2012*	Installation Specifications; TI-2012	A-185698
TI-2015*	Installation Specs; TI-2015	A-173484
TI-2019	Installation Specs; TI-418/RO-2011/ CT-2001/TI-2019	A-169380
TI-2024	Installation Specs; TI-2024	A-236147

**These are portable timing/counting models, and no fixed installation is required; the drawings show options for permanent mounting.*

Refer to the installation specification drawings listed in the chart on the previous pages for the rear view of each of the models. These drawings specify the number of beams and the recommended spacing between them. The drawings also indicate the size of beams required to support the scoreboard at different heights and under various wind speed conditions. All of the beam specifications illustrate W-shape steel beams (wide-flange I-beams). The first number indicates the front-to-rear depth of the beam and the second number indicates the weight in pounds per foot of length.

The column and footing size dimensions provided assist with estimating installation costs. They are estimates only and are not intended for construction purposes. Be sure that the installation complies with local building codes and is suitable for the particular soil and wind conditions.

The columns, footings and all connection details must be designed and certified by a professional engineer licensed to practice in the state in which the scoreboard will be installed.

Note: Daktronics does not assume any liability for any installation derived from the information provided in this manual or installations designed and installed by others.

Lifting the Scoreboard

Reference Drawings:

Lifting Scoreboard	Drawing A-44548
Lifting Small Baseball Scoreboard	Drawing A-58668

Small Daktronics scoreboards are not equipped with eyebolts. Refer to **Drawing A-58668** for lifting details.

Larger scoreboard sections and message centers are shipped equipped with eyebolts that are used to lift the displays. The eyebolts are located along the top of the cabinet for each scoreboard or scoreboard section.

Daktronics strongly recommends using a spreader bar, or lifting bar, to lift the display. Using a spreader bar ensures that the force on the eyebolts is straight up, minimizing lifting stress. Lifting methods are shown in **Figure 3** and in **Drawing A-44548**.

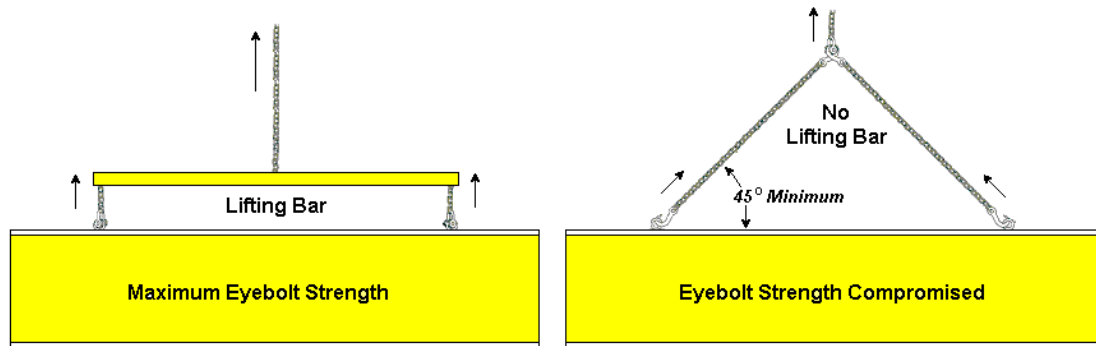

Figure 3: Lifting the Display

Figure 3 illustrates both the preferred method (left example) and an alternative method (right example) for lifting a scoreboard. When lifting the display:

- Use a spreader bar.
- Use every lifting point provided.

Take special care not to exceed the rated load of the eyebolts. Refer to [ED-7244](#), **Eyebolts**, to determine allowable loads and load angles for the lifting hardware. [ED-7244](#) is located in **Appendix B** of this manual.

Avoid using other lifting methods. Cables and chains attached to the eyebolts and directly to a center lifting point, as shown in the right-hand example in **Figure 3**, can create a dangerous

lateral force on the eyebolts and may cause the eyebolts to fail. Daktronics scoreboards use $\frac{1}{2}$ " and $\frac{5}{8}$ " shoulder-type eyebolts mounted to a $\frac{1}{8}$ " aluminum plate or steel nut plate, but exceeding load angles or weight limits could cause the bolts to pull out of the scoreboard cabinet to buckle. In either circumstance, there could be serious damage to the scoreboard. If you must use this method, ensure a minimum angle between the chain and scoreboard of at least 45 degrees.

Note: Daktronics assumes no liability for scoreboard damage resulting from incorrect setup or incorrect lifting methods.

Eyebolts are intended for lifting only. Do not attempt to permanently support the display by the eyebolts.

In installations in which an ad panel or some other scoreboard section may be added to the base display, the lower scoreboard section is installed first and secured to the support beams, and then the upper section is placed atop or above the lower section and attached to the beams. There may be cables extending from the top of the lower section. Guide these cables into the hole in the bottom of the upper section for later connection.

If installers remove the lift eyebolts, plug the holes with bolts and the rubber sealing washers used with the eyebolts. Apply silicone or another waterproof sealant to the eyebolt openings. Inspect the top and sides of the display for any other holes or openings that may allow moisture to enter the display and plug and seal those openings as well.

6.3 Scoreboard Mounting

There are two basic styles for mounting Daktronics single-section outdoor scoreboards. Installation procedures are detailed later in this section. Use the following tables to determine the mounting method required for each scoreboard:

Method 1		
BA-618	BA-2016	MS-2004
BA-624	BA-2017	MS-2011
BA-1018	BA-2019	MS-2012
BA-2004	BA-2022	SO-918
BA-2005	CR-2003	SO-2008
BA-2010	FB-824	SO-2013
BA-2011	MS-2002	
BA-2014	MS-2003	
Method 2		
BA-515	MS-2006	TI-2015
BA-518	RO-2010	TI-2019
BA-718	RO-2011	TI-2024
BA-2003	TI-215	
BA-2023	TI-218	
BA-2024	TI-418	
CR-2002	TI-2003	
CT-2001	TI-2010	
MS-915	TI-2012	

Mounting Method 1

Reference Drawings:

Display Mounting	Drawing A-44412
Ad Panel Mounting	Drawing A-52187

Drawing A-44412 shows the hardware used for mounting the scoreboard to the beams. Mounting hardware includes inner and outer mounting clamps, clip angles, $1/2$ -13 x 15" threaded rods, $3/8$ -16 x 2" bolts, hex nuts and split lockwashers, and $1/2$ " square nuts, hex nuts, and split lockwashers. Each section of the scoreboard attaches at the top and the bottom to all the beams. The drawing also shows top and side views of the scoreboard secured to the beams.

Note: The threaded rods do not pass through the flanges of the beams, but instead run along both sides of each beam.

Refer to the installation specifications drawing for your scoreboard model (listed in **Section 6.2**) to determine the center-to-center distance of the poles for each model. Review the illustration of the mounting hardware in **Drawing A-44412**, or refer to **Figure 4**, and then use the following procedure for each section.

1. Using $3/8$ " bolts, loosely attach the inner and outer mounting clamps to the rear flanges of the scoreboard horizontal frame members. Measure the beam spacing and position the clamps to fit on either side of the beams.
2. Insert a $1/2$ " square nut into each mounting clamp. Screw a threaded rod into each of the nuts from the rear.
3. Position the scoreboard at the front of the beams with the threaded rods extending from the rear of the clamps, straddling the beams. Raise the scoreboard section to the desired height.
4. Slide clamping angles over the ends of the rods and loosely install the washers and nuts.
5. Make final adjustments in the positioning of the scoreboard. Tighten the $3/8$ " bolts in the mounting clamps.
6. Make sure that the threaded rods are perpendicular to the scoreboard and tighten all of the $1/2$ " nuts.

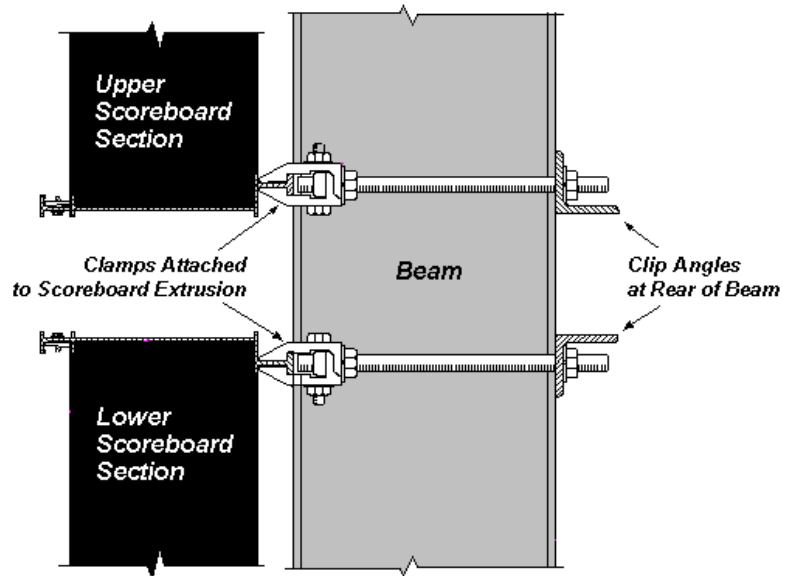

Figure 4: Clamp Mounting Method, Side View

Mounting Method 2

Reference Drawing:

Scoreboard Mounting **Drawing A-55101**

These scoreboard models use an inverted channel mounting, illustrated in **Drawing A-55101**. Refer to any installation specifications drawing (listed in **Section 6.2**) for your model to determine the center-to-center distance of the poles.

The installation uses C-channel; mounting angles, $\frac{1}{2}$ -13" threaded rod, and $\frac{1}{2}$ " square nuts, hex nuts and lockwashers. Mount the scoreboard as follows:

1. Place the C-channel against the upper and lower rear flanges of the scoreboard cabinet, as shown in **Drawing A-55101** and **Figure 5**.

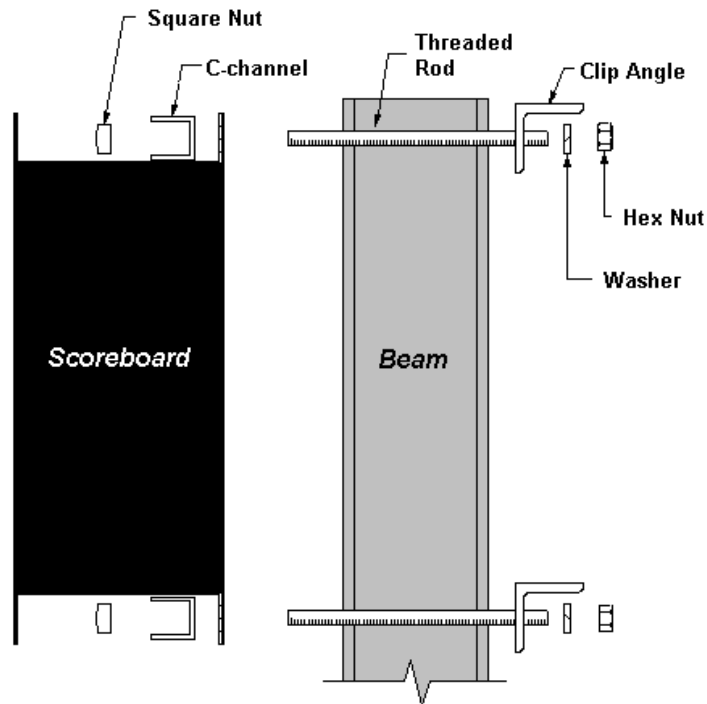

Figure 5: Mounting with C-channel, Side View

2. Use the mounting channel to determine the appropriate hole combination to use. Be sure to keep the bolts as close to the beam as possible.
3. Using the mounting channel as a template, drill $\frac{9}{16}$ " holes in the upper and lower rear flanges of the scoreboard where the supports will be placed.
4. Place the $\frac{1}{2}$ " square nuts inside the C-channel and thread the $\frac{1}{2}$ -13" bolts through the channel and the back flange of the display cabinet.
5. Lift the scoreboard into position with the bolts still in place. Position the scoreboard at the front of the beams with the threaded rods extending from the rear flanges of the display.
6. With the threaded rod straddling the beams, place mounting angles over each pair of bolts and secure with $\frac{1}{2}$ " lockwashers and hex nuts.
7. Make final adjustments in the position of the scoreboard, and after verifying that the threaded rods are perpendicular to the display, firmly tighten all of the $\frac{1}{2}$ " hex nuts.

Scoreboard Mounting Using Spacers

Reference Drawing:

Scoreboard Mtg; Scoreboard with Spacers **Drawing A-182909**

Many Daktronics customers add message centers or advertising panels to the top or bottom of their scoreboards, and in some cases the depth of the add-on component may not match the depth of the scoreboard. (Scoreboards in this series are typically 6" or 11" deep.)

To create a uniform appearance for the overall display, Daktronics recommends using spacers behind the scoreboard so that the front face of the display lines up evenly with the front face of the added component. The concept is illustrated in **Figure 6**.

Drawing A-182909 provides complete details for inserting spacers. During the installation, spacers are placed between the mounting beams and the back of the scoreboard cabinet. Spacer size is determined by the height and the extra depth required for the front surface of the scoreboard to match that of the optional message center or ad panel.

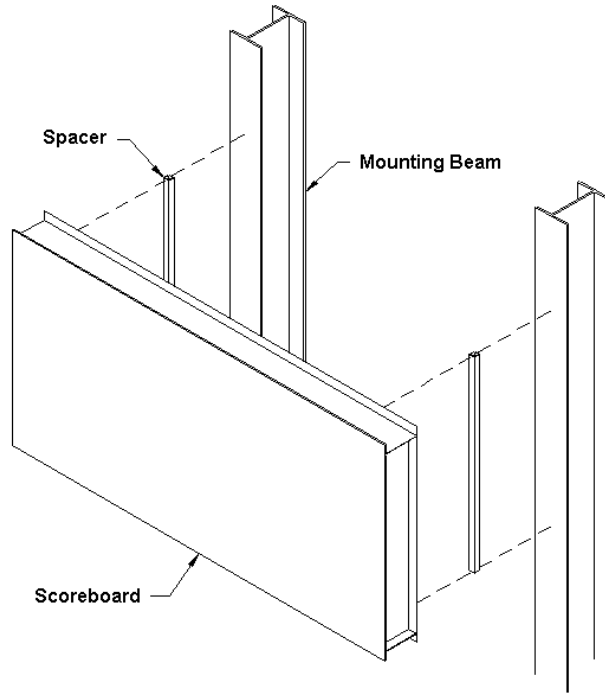

Figure 6: Mounting with Spacers

Note: Daktronics does not provide these spacers.

Ad Panel Mounting

Reference Drawings:

Ad Panel Mounting.....	Drawing A-52187
Assembly, Ad Panel, BA-515.....	Drawing A-52585
Ad Panel Mounting, BA-518.....	Drawing A-52811

Refer to **Drawing A-52187** for mounting details. The installation uses C-channel, mounting angles, 1/2-13" threaded rod, and 1/2" square nuts, hex nuts, and lockwashers.

Mount the ad panel or panels in the following manner:

1. Use the mounting channel to determine which hole combination to use. Be sure to keep the bolts as close to the beam as possible.
2. Using the mounting channel as a template, drill 9/16" holes in the upper and lower rear flange of the ad panel where the C-channel supports will be placed.
3. Position the C-channel *inside* the ad panel cabinet along the upper and lower back flanges.
4. Place square nuts inside the channel and thread the long rods through both the C-channel and the flange.
5. Lift the ad panel into position with the rods still in place.
6. With the threaded rod straddling the beams, place mounting angles over each pair of bolts and secure with 1/2" lockwashers and hex nuts.
7. When the panel is adjusted to the final desired position, tighten hex nuts firmly.

Some ad panels have back sheets that must be removed before the display can be installed. After marking and drilling holes in the upper and lower rear flanges of the ad panel, remove the back sheets above and below the hole locations. Position the C-channel inside the cabinet and attach the square nuts to the threaded rods as described above. Be sure to replace the back sheets after placing the square nuts inside the channel and threading the rods through the holes in the upper and lower flanges.

Models BA-515-11 and BA-518-11

With Models BA-515-11 and BA-518-11, ad panels can be mounted directly to the end of the scoreboard. Refer to **Drawings A-52585** and **A-52811** for mounting details.

Section 7: Electrical Installation

Electrical installation consists of the following processes:

- Providing power and ground to a disconnect near the scoreboard.
- Routing power and ground from the main disconnect to the scoreboard driver/power enclosure.
- Connecting the scoreboard ground to a grounding electrode at the scoreboard location.
- Routing the control signal cable from the control location to the scoreboard location.

Note: Only qualified individuals should perform power routing and termination to the display. It is the responsibility of the electrical contractor to ensure that all electrical work meets or exceeds local and national codes.

7.1 Power

Reference Drawings:

Schematic, Multipurpose LED Driver.....	Drawing A-165028
Schematic; Gen III & IV OD LED, 3 Drvr Display	Drawing A-179541
Schematic; Gen III & IV, OD LED, 1 Drv w/TNMC	Drawing A-179790
Schematic; Gen III & IV, OD LED, 3 Drv w/TNMC	Drawing A-180081
Schematic; Gen III & IV, O.D. LED, 2 Drvr Display	Drawing A-180637
Schematic; Gen IV Outdoor LED, 16 Column Drvr	Drawing A-285779
Schematic, Gen IV Outdoor Driver, 8 Column Driver.....	Drawing A-285881
Schematic; Baseball w/S.O.P. GEN IV, optional TNMC	Drawing B-204725
Schematic; GEN III & IV OD LED, 1 DRVR W/S.O.P.....	Drawing B-210454

Daktronics outdoor LED scoreboards have been designed for easy access to components, and the power and control signal hookup has been simplified. Front panels are removable to allow access to the digits, cabling, and other electronic components.

Correct power installation is imperative for proper display operation. The subsections that follow give details of display power installation. Only qualified individuals should attempt to complete the electrical installation; untrained personnel should not attempt to install these displays or any of the electrical components. Improper installation could result in serious damage to the equipment and could be hazardous to personnel.

The single-section outdoor scoreboards require a dedicated, 120 V circuit for incoming power. The display itself has no breakers or fuses.

WARNING: It is critical that the scoreboard circuit be fused at 15 A and that all conductors used must be designed to pass a 15 A current in normal operation. Failure to meet wiring and overcurrent protection device requirements is a violation of the National Electrical Code® and will void the scoreboard warranty.

All power conductors are 14 AWG, except where 18 AWG wiring is called out on the schematic. All signal conductors are 18 AWG.

Refer to the outdoor scoreboard schematics listed at the beginning of this section and to the tables in **Section 3** to determine circuit specifications and maximum power requirements for the models described in this manual.

Grounding

Reference Drawings:

Schematic; Multipurpose LED DRVR.....	Drawing A-165028
Schematic; Gen III & IV OD LED, 3 Drvr Display	Drawing A-179541
Schematic; Gen III & IV, OD LED, 1 Drv w/TNMC.....	Drawing A-179790
Schematic; Gen III & IV, OD LED, 3 Drv w/TNMC.....	Drawing A-180081
Schematic; Gen III & IV, O.D. LED, 2 Drvr Display	Drawing A-180637
Schematic; Gen IV Outdoor LED, 16 Column Drvr	Drawing A-285779
Schematic, Gen IV Outdoor Driver, 8 Column Driver.....	Drawing A-285881
Schematic; Baseball w/S.O.P. GEN IV, optional TNMC	Drawing B-204725
Schematic; GEN III & IV OD LED, 1 DRVR W/S.O.P.	Drawing B-210454

Note: Displays **MUST** be grounded according to the provisions outlined in Article 250 of the National Electrical Code and according to the specifications in this manual. Daktronics recommends a resistance-to-ground of 10 ohms or less.

The electrical contractor performing the electrical installation can verify ground resistance. Daktronics Sales and Service personnel can also provide this service.

The display system *must* be connected to an earth electrode installed at the display. Proper grounding is necessary for reliable equipment operation. It also protects the equipment from damaging electrical disturbances and lightning.

Note: The display must be properly grounded, or the warranty will be void.

Refer to the schematics listed at the beginning of this section for information about ground wire connection. The connection is illustrated in the “Pwr In” detail on each of the schematics.

The material for an earth-ground electrode differs from region to region and may vary according to conditions present at the site. Consult the National Electrical Code and any local electrical codes that may apply. The support structure of the display cannot be used as an earth-ground electrode. The support is generally embedded in concrete, and if it is in earth, the steel is usually primed or it corrodes, making it a poor ground in either case.

Power Installation

There are two types of power installation: installation with ground and neutral conductors provided, and installation with only a neutral conductor provided.

These two power installations differ slightly, as described in the following paragraphs:

Installation with Ground and Neutral Conductors Provided

For this type of installation, the power circuit *must* contain an isolated earth-ground conductor. In this circumstance, *do not* connect neutral to ground at the disconnect or at the display.

Note: This would violate electrical codes and void the warranty.

Use a disconnect so that all hot lines are neutral can be disconnected. The National Electrical Code requires the use of a lockable power disconnect within sight of or at the display.

Installation with Only a Neutral Conductor Provided

Installations where no grounding conductor is provided must comply with Article 250-32 of the National Electrical Code. If the installation in question meets all of the requirements of Article 250-32, the following guidelines must be observed:

- Connect the grounding electrode cable at the local disconnect, never at the display driver/power enclosure.
- Use a disconnect that opens all of the ungrounded phase conductors.

7.2 Power and Signal Connection

Reference Drawings:

Schematic, Multipurpose LED Driver	Drawing A-165028
Schematic; Gen III & IV OD LED, 3 Drvr Display	Drawing A-179541
Schematic; Gen III & IV, OD LED, 1 Drv w/TNMC	Drawing A-179790
Schematic; Gen III & IV, OD LED, 3 Drv w/TNMC	Drawing A-180081
Schematic; Gen III & IV, O.D. LED, 2 Drvr Display	Drawing A-180637
Driver Assy; Gen III & IV Outdoor LED, 8 Col Master	Drawing A-284922
Driver; Gen III & IV Outdoor LED, 16 Col Master	Drawing A-284920
Schematic; Gen IV Outdoor LED, 16 Column Drvr	Drawing A-285779
Schematic, Gen IV Outdoor Driver, 8 Column Driver	Drawing A-285881
Schematic; Baseball w/S.O.P. GEN IV, Optional TNMC	Drawing B-204725
Schematic; GEN III & IV OD LED, 1 DRVR W/S.O.P.	Drawing B-210454

Route power and signal cables into the scoreboard from the rear. There are two plastic plugs for conduit connection in the back. All power and signal wiring terminates at the driver enclosure. **Drawings A-284920** and **A-284922** illustrate the 16- and 8-column drivers used in Daktronics outdoor LED scoreboards.

To gain access to the driver enclosure, open the access door or digit panel and remove the cover from the enclosure. Refer to the component locations drawings for the access location for the scoreboard.

Connect power and signal cables at the appropriate locations on the driver enclosure panel, shown in **Drawings A-284920** and **A-284922**.

The conventional power termination panel has been eliminated from Daktronics outdoor scoreboards; the power feeder circuit connects directly to a terminal block in the driver enclosure, as shown in **Figure 7**. The terminal block is located in the lower right corner of the enclosure. Connect the power wires as shown in the illustration. Refer to the driver engineering drawings and to the schematics listed at the beginning of this section for additional wiring details. The schematics include a detailed illustration of the power termination.

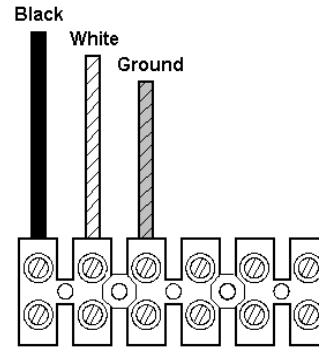

Figure 7: Power Terminal Block

Note: If a power receptacle is needed to operate the control console at the scoreboard for troubleshooting, Daktronics recommends that an installation electrician provides a 120 V outlet close to the disconnect box specifically for this purpose.

Route signal cabling to the signal surge arrester card in the upper left corner of the driver enclosure. The connections are labeled to permit easy installation. At the Signal In terminal block on the PCB, connect the red signal wire to the positive terminal, the black to the negative terminal, and the shield (silver) wire to the shield terminal.

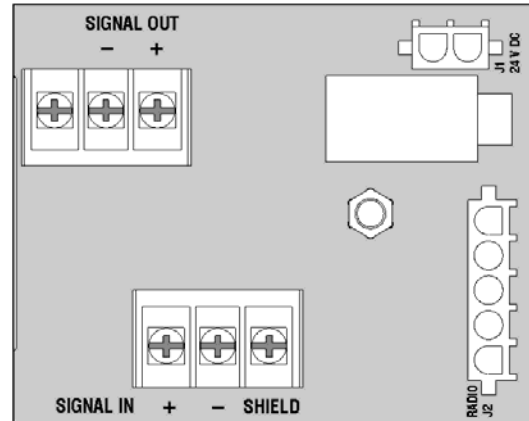

Figure 8: Signal Surge Arrester Card

Note: It is important that the shield wire is properly connected to the shield terminal on the signal surge arrester card. **Figure 8** illustrates the signal surge arrester card and connectors.

For signal cable, Daktronics recommends, as a minimum, single-pair, shielded cable, 22 AWG (Daktronics part number W-1077). Two-pair shielded cable (Daktronics part W-1614) is preferred.

Fiber Optic

Another common signal communication method is using fiber optic cabling. A minimum cabling of multi-mode; 62.5/125 μm ; and 2-core fiber cable is recommended. (Daktronics part number is W-1242.) See **Figure 9** for the location of fiber connector on the LED driver. (See **Drawing A-288137** for the complete image of the LED driver.)

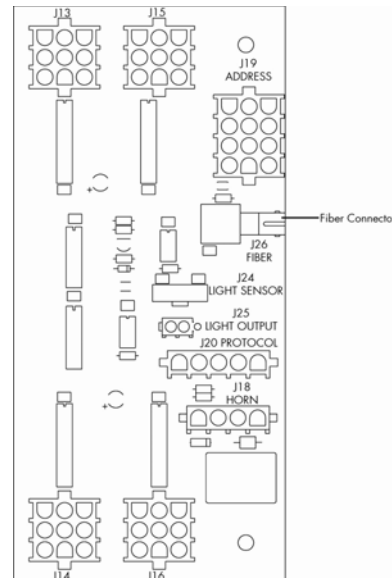

Figure 9: Driver Fiber Connection Location

For additional information on signal connection, refer to the All Sport 5000 Series control console operation manual, [ED-11976](#).

Multiple Driver Connections

Some models in the single-section outdoor scoreboard line require multiple drivers, and those models have been configured to operate with a master/slave driver system. Master and slave drivers function identically, but slave units lack the power termination block and signal surge suppression card. The two drivers have been designed to simply plug into one another via an interconnect harness, the slave receiving power and redriven signal from the master driver enclosure. Larger boards can add as many driver slaves as they require.

All driver interconnect harnesses are factory-installed. No additional connection is necessary. (The harness emerges from the bottom of the master driver enclosure, and the J42 jack from the master is connected to the slave's P43 plug.) Likewise, signal cables from drivers to digits have also been factory-installed and no additional connection is necessary.

Refer to the scoreboard drawings to determine driver location and other model-specific information.

Section 8: Scoreboard Maintenance and Troubleshooting

IMPORTANT NOTES:

1. Disconnect power before doing any repair or maintenance work on the scoreboard.
2. Permit only qualified service personnel to access internal display electronics.
3. Disconnect power when not using the scoreboard.

Note: For assistance in the maintenance of team name message centers or other optional scoreboard message centers, please refer to **Section 9** or the service manual that accompanies those units.

8.1 Cabinet Specifications

Cabinets for the Daktronics outdoor LED scoreboards are constructed of heavy-gauge aluminum. Exact dimensions and weights for each model are listed in the chart in **Section 3**. Removable panels for digits and indicators and for component access are detailed in each model's component locations drawing, listed in **Section 4**.

8.2 Component Location and Access

For front-access scoreboards, all internal electronic components and digits can be reached by opening a face panel, an access door or a digit panel on the front of the display.

Digit panels have been simplified on the outdoor LED scoreboards. They are held in place on the scoreboard face by an offset flange across the top and by three screws at the bottom, as shown in **Figure 10**. (Very large digits may have additional screws across the bottom.) Open the scoreboard with care. Hold the digit panel in place by putting hand pressure on it while removing the screws, and carefully lift it from the board, sliding it out and down.

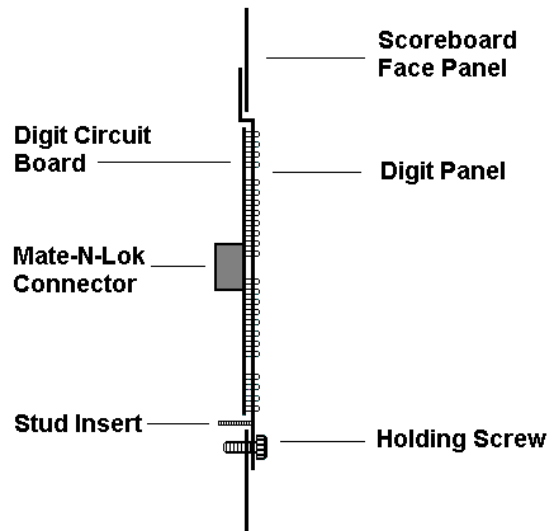

Figure 10: LED Digit Panel

If the panel is not held in place, it could drop immediately when the screw is removed, possibly damaging LEDs or the digit harness. (A stud insert on the back of the digit panel is designed to minimize damage from dropping.)

Component location varies with each scoreboard model, but drivers, power and signal components are typically mounted inside the scoreboard behind an access panel or a digit.

With a non-digit access panel, simply remove the top, side and bottom screws holding it in place. Some panels are hinged and swing open when the screws are removed or loosened.

Note: Disconnect power before servicing the display. Power should also be disconnected when the display is not in use. Prolonged power-on may shorten the life of some electronic components.

Replacing a Digit

The digit circuit board, the platform for the LEDs, is mounted to the back of the digit panel. See **Figure 11** below. Do not attempt to remove individual LEDs. In the case of a malfunctioning board, replace the entire digit panel.

To remove a scoreboard digit, follow these steps:

1. Open the digit panel as described in the preceding section.
2. Disconnect the power/signal connector from the back of the digit. Release the connector by squeezing together the locking tabs as you pull the connector free.
3. The digits are secured to the inside of the panel with fixed machine screws, spacers, and push nuts. Remove the nuts and lift the digit off the standoff screws. (The push nuts can be removed in several ways, but Daktronics recommends using a $9/32$ " nut driver.)
4. Position a new digit over the screws and tighten the nuts.
5. Reconnect the power/signal connector.

Note: This is a keyed connector B it will attach in one way only. Do not attempt to force the connection!

6. Close and secure the digit panel and test the scoreboard.

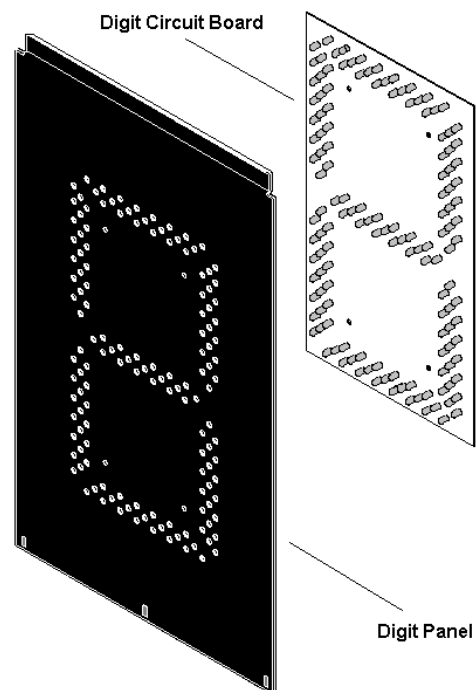

Figure 11: Digit Assembly

Replacing a Digit Segment

Reference Drawing:

Digit Assemblies; LED Digits **Drawing B-177679**

When a digit malfunctions, in most cases it is necessary to replace the entire digit circuit board. Some larger digits (24", 30", 36", 60"), however, are constructed in segments, as shown in **Figure 12**, and it may be possible to make repairs by removing only the defective segment. As with smaller digits, the digit segment circuit boards are mounted to the back of the digit panel.

Note: Do not attempt to remove individual LEDs.

Refer to **Drawing B-177679**.

To remove a digit segment, follow these steps:

1. Open the digit panel as described above.
2. Disconnect the 2-pin power/signal connector from the back of the individual segment. Release the connector by squeezing together the locking tabs as you pull the connector free.
3. The individual segments are secured to the inside of the panel with fixed machine screws, spacers and push nuts. Remove the nuts and lift the segment off the standoff screws.
4. Position a new segment over the screws and tighten the nuts.
5. Reconnect the power/signal connector.

Note: This is a keyed connector B it will attach in one way only. Do not attempt to force the connection!

6. Close and secure the digit panel and test the scoreboard.

Note: Replace a malfunctioning colon, decimal or indicator assembly in the same manner.

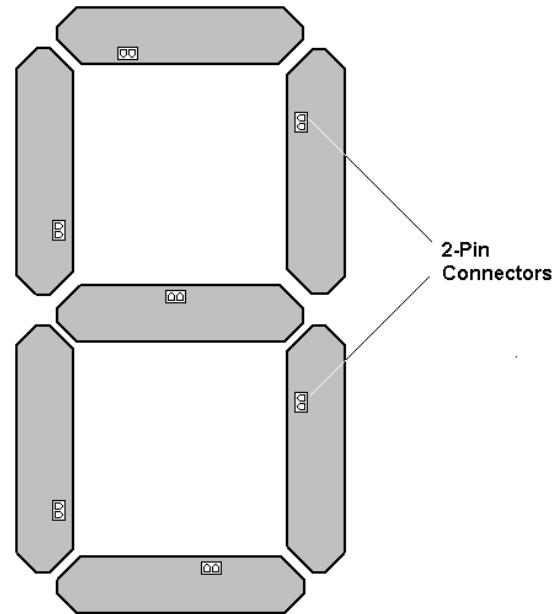

Figure 12: Segmented Digit Panel (Rear View)

Replacing a Driver

Drivers are typically mounted inside the scoreboard and immediately behind a digit, but location and mounting varies with the model of the scoreboard. Refer to the component locations drawings in **Section 4** for the location of the scoreboard driver. All scoreboards in this manual are front-accessible. Each driver is enclosed with a power supply and signal terminal block. Before a failed driver can be reached, the enclosure must be accessed. Follow these steps:

1. Open the digit panel or scoreboard face panel as described in **Section 8.2**.
2. Remove the cover from the driver enclosure.
3. Disconnect all connectors from the driver. Release each connector by squeezing together the locking tabs as you pull the connector free.

Note: This is a keyed connector and will attach in one way only. Do not attempt to force the connections!

4. Remove the screws, nuts or wing nuts securing the driver to the inside of the enclosure. Refer to **Figure 13**.
5. Carefully lift the driver from the display and place it on a clean, flat surface.
6. Follow steps 1 through 5 in reverse order to attach a new driver.

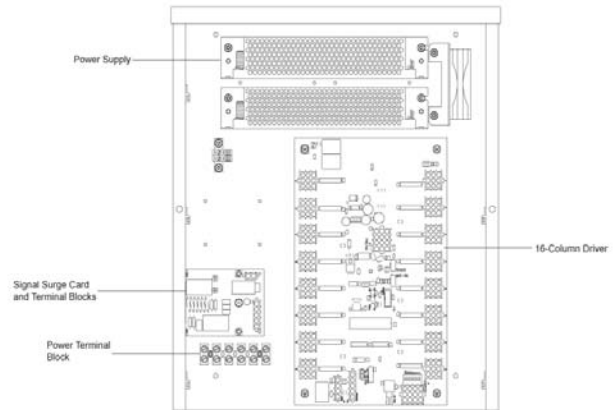

Figure 13: 16-column driver enclosure

8.3 Schematic

Reference Drawings:

Schematic, Multipurpose LED Driver	Drawing A-165028
Schematic; Gen III & IV OD LED, 3 Drvr Display.....	Drawing A-179541
Schematic; Gen III & IV, OD LED, 1 Drv w/TNMC.....	Drawing A-179790
Schematic; Gen III & IV, OD LED, 3 Drv w/TNMC.....	Drawing A-180081
Schematic; Gen III & IV, O.D. LED, 2 Drvr Display.....	Drawing A-180637
Harness Assembly Diagram; 60" Digit.....	Drawing A-232925
Schematic; 60" LED Clock	Drawing A-273885
Schematic; Gen IV Outdoor LED, 16 Column Drvr.....	Drawing A-285779
Schematic, Gen IV Outdoor Driver, 8 Column Driver	Drawing A-285881
Schematic; Baseball w/S.O.P. GEN IV, Optional TNMC	Drawing B-204725
Schematic; GEN III & IV OD LED, 1 DRVR W/S.O.P.	Drawing B-210454

Drawings A-285881, A-285779, A-179790, A-179541, A-180081, A-180637, B-204725 and B-210454 are the schematic diagrams for the 8- and 16-column drivers used in Daktronics outdoor single-section scoreboards. The schematics include power and signal inputs and all wiring for the models described in this manual. Refer to **Section 5** for a complete listing of scoreboards, their drivers and the appropriate schematic.

8.4 LED Drivers

Reference Drawings:

Address Table, 1 Through 128	Drawing A-115078
Driver; Gen IV Outdoor LED, 16 Col Master	Drawing A-284920
Driver; GEN IV Outdoor LED, 8 Col Master.....	Drawing A-284922
Specifications; LED Driver IV, 16 Col	Drawing A-288137
Specifications; LED Driver IV, 8 Col	Drawing A-288138
Address Table 1; GEN IV Driver Address Dip Switch.....	Drawing A-290261

The LED drivers are located inside of a driver enclosure. The driver enclosures are found on **Drawings A-284920** and **A-284922**.

In the scoreboard, the LED drivers perform the task of switching digits on and off. To view the LED drivers, refer to **Drawings A-284137** and **A-284138**. Each driver has up to 26 connectors providing power and signal inputs to the circuit and outputs to the digits and indicators. The connectors function as follows:

8-Column LED Driver	
<i>Connector No.</i>	<i>Function</i>
1 – 8	Output to digits and indicators
17	Controls power/signal
16-Column LED Driver	
<i>Connector No.</i>	<i>Function</i>
1 – 16	Output to digits and indicators
17	Controls power/signal

Output connectors 1 through 16 each have nine pins. Pin 7 provides power (hot) to the digit or indicators wired to that connector. The other eight pins provide switching connections.

For the scoreboard to receive signal and function properly, the driver must be set to the correct address. This address is set with jumper wires in a 12-pin plug which mates with a jack on the driver. **Drawings A-288137** and **A-288138** detail the specifications for both the 16- and the 8-column drivers.

Address settings can be configured by using the SI dip switch. See **Drawing A-290261** for more information. The older method using the J19 address plug is still available. Refer to **Drawing A-115078** for a listing of the wire/ pin connections for driver addresses 1 – 128.

8.5 Segmentation and Digit Designation

Reference Drawing:

Segmentation, 7 Segment Bar Digit	Drawing A-38532
60" Digit Assy.....	Drawing A-197586
Harness Assembly Diagram; 60" Digit	Drawing A-232925

In each digit, certain LEDs always go on and off together. These groupings of LEDs are referred to as *segments*. **Drawing A-38532** illustrates digit segmentation. It also details which connector pin is wired to each digit segment and the wiring color code used throughout the display.

The component locations drawings in **Section 4** specify the driver connectors controlling the digits. Numbers displayed in hexagons in the upper half of each digit, as shown in **Figure 14**, indicate which connector is wired to that digit. (The lower number in the square indicates nominal digit size.)

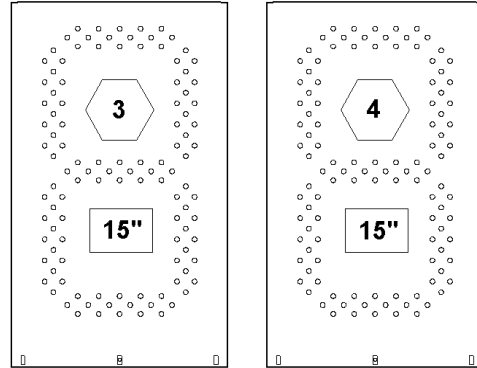

Figure 14: Digit Designation

For 60" digit assembly and wiring for the FB-2410 refer to **Drawings A-197586** and **A-232925**.

8.6 Lightning Protection

The use of a disconnect near the scoreboard to completely cut all current-carrying lines significantly protects the circuits against lightning damage. The National Electrical Code also requires the disconnect. In order for this system to provide protection, the power *must* be disconnected when the scoreboard is not in use. The control console should also be disconnected from power and from the signal junction box when the system is not in use. The same surges that may damage the scoreboard's driver can also damage the console's circuit.

8.7 Replacement Parts

Refer to the following table for Daktronics scoreboard replacement parts.

Description	Location	Daktronics Part No.
J-Box, 1/4" phone, Indoor	Signal	0A-1009-0038
J-Box, 1/4" Phone, outdoor	Signal	0A-1091-0227
12V DC trumpet horn, AS5000; Outdoor	Scoreboard	0A-1091-1213
Signal surge arrestor	Driver enclosure	0P-1110-0011
Driver, 4 col MASC, outdoor, LED	Driver enclosure	0P-1192-0068
Digit, 15", 7-seg outdoor LED, red	Scoreboard	0P-1192-0200
Digit, 18", 7-seg outdoor LED, red	Scoreboard	0P-1192-0202
Digit, 18" ones, 7-seg outdoor LED, red	Scoreboard	0P-1192-0203
Digit segment, 24" outdoor LED, red (vertical)	Scoreboard	0P-1192-0204
Digit segment, 24" outdoor LED, red (horizontal)	Scoreboard	0P-1192-0205
Digit segment, 30" outdoor LED, red (vertical)	Scoreboard	0P-1192-0206
Digit segment, 30" outdoor LED, red (horizontal)	Scoreboard	0P-1192-0207
Digit segment, 36" outdoor LED, red (vertical)	Scoreboard	0P-1192-0208
Digit segment, 36" outdoor LED, red (horizontal)	Scoreboard	0P-1192-0209
Digit, 15", 7-seg outdoor LED, amber	Scoreboard	0P-1192-0214
Digit, 18", 7-seg outdoor LED, amber	Scoreboard	0P-1192-0216
Digit, 18" ones, 7-seg outdoor LED, amber	Scoreboard	0P-1192-0217
Digit segment, 24" outdoor LED, amber (vertical)	Scoreboard	0P-1192-0218
Digit segment, 24" outdoor LED, amber (horizontal)	Scoreboard	0P-1192-0219
Digit segment, 30" outdoor LED, amber (vertical)	Scoreboard	0P-1192-0220
Digit segment, 30" outdoor LED, amber (horizontal)	Scoreboard	0P-1192-0221
Digit segment, 36" outdoor LED, amber (vertical)	Scoreboard	0P-1192-0222
Digit segment, 36" outdoor LED,	Scoreboard	0P-1192-0223

Description	Location	Daktronics Part No.
amber (horizontal)		
Indicator, 2" circular, outdoor LED, red	Scoreboard	0P-1192-0228
Indicator, 2" circular, outdoor LED, amber	Scoreboard	0P-1192-0229
Indicator, 4" circular, outdoor LED red	Scoreboard	0P-1192-0244
Indicator, 4" circular outdoor LED amber	Scoreboard	0P-1192-0245
Digit, 10", 7-seg outdoor LED, red	Scoreboard	0P-1192-0255
Digit, 10", 7-seg outdoor LED, amber	Scoreboard	0P-1192-0256
60" Red Hor Half Seg	FB-2410	0P-1192-0280
60" Red Vert Half Seg	FB-2410	0P-1192-0281
60" Amber Hor Half Seg	FB-2410	0P-1192-0282
60" Amber Vert Half Seg	FB-2410	0P-1192-0283
8 Segment Breakout Board	FB-2410	0P-1192-0326
Driver, 16 col, outdoor, LED	Driver enclosure	0P-1192-0383
Driver, 8 col, outdoor, LED	Driver enclosure	0P-1192-0391
4" Red DOT for Colon	FB-2410	0A-1192-3274
4" Amber DOT for Colon	FB-2410	0A-1192-3275
Assy; 100 Watt Power/Signal enclosure	FB-2410	0A-1192-3316
Power supply, 24 V, 150W, 86-132 V input	Driver enclosure	A-1720
Fan, 32 cfm, 24 V DC, 3.15 sq. in	Driver enclosure	B-1030
Plug, 1/4" phone	Signal	P-1003
Signal cord; 1/4" phone 20'	Signal	W-1236
Signal cord; 1/4" phone 50'	Signal	W-1237
Signal cord; 1/4" phone 30'	Signal	W-1238

8.8 Troubleshooting

This section lists potential problems with the scoreboard and indicates possible causes and corrective actions. This list does not include every possible problem, but does represent some of the more common situations that may occur.

Symptom/Condition	Possible Cause
Scoreboard will not light	<ul style="list-style-type: none">▪ Console not connected or poor connection▪ No power to control console▪ No power to the scoreboard
Garbled display	<ul style="list-style-type: none">▪ Internal driver logic malfunction▪ Control console malfunction
Digit will not light	<ul style="list-style-type: none">▪ Black wire to digit broken▪ Poor contact at driver connection.▪ Driver malfunction
Segment will not light	<ul style="list-style-type: none">▪ Broken LED or connection▪ Driver output failure▪ Broken wire between driver and digit▪ Poor contact at driver connector
Segment stays lit	<ul style="list-style-type: none">▪ Driver output failure▪ Short circuit on digit
Date appears in the wrong place on the scoreboard	<ul style="list-style-type: none">▪ Incorrect address settings on drivers (consult tables and set correct addresses)

8.9 Daktronics Exchange and Repair & Return Programs

To serve customers' repair and maintenance needs, Daktronics offers both an Exchange Program and a Repair & Return Program.

Exchange Program

Daktronics unique Exchange Program is a quick service for replacing key parts in need of repair. If a part requires repair or replacement, Daktronics sends the customer a replacement, and the customer sends the defective part to Daktronics. This decreases display downtime.

Before Contacting Daktronics

Identify these important part numbers:

Display Serial Number: _____

Display Model Number: _____

Contract Number: _____

Date Installed: _____

Daktronics Customer ID Number: _____

To participate in the Exchange Program, follow these steps.

1. Call Daktronics Customer Service.

Market Description	Customer Service Number
Schools (primary through community/junior colleges), religious organizations, municipal clubs and community centers	877-605-1115
Universities and professional sporting events, live events for auditoriums and arenas	866-343-6018
Financial institutions, petroleum, sign companies, gaming, wholesale/retail establishments	866-343-3122
Department of Transportation, mass transits, airports, parking facilities	800-833-3157

2. When the new exchange part is received, mail the old part to Daktronics.

If the replacement part fixes the problem, send in the problem part which is being replaced.

- a. Package the old part in the same shipping materials in which the replacement part arrived.
- b. Fill out and attach the enclosed UPS shipping document.
- c. Ship the part to Daktronics.

3. A charge will be made for the replacement part immediately, unless a qualifying service agreement is in place.

In most circumstances, the replacement part will be invoiced at the time it is shipped.

- 4. If the replacement part does not solve the problem, return the part within 30 working days or the full purchase price will be charged.**

If, after the exchange is made the equipment is still defective, please contact Customer Service immediately. Daktronics expects *immediate return* of an exchange part if it does not solve the problem. The company also reserves the right to refuse parts that have been damaged due to acts of nature or causes other than normal wear and tear.

Repair & Return Program

For items not subject to exchange, Daktronics offers a Repair & Return Program. To send a part for repair, follow these steps:

- 1. Call or fax Daktronics Customer Service:**
Refer to the appropriate market number in the chart listed on the previous page.
- 2. Receive a Return Materials Authorization (RMA) number before shipping.**
This expedites repair of the part.
- 3. Package and pad the item carefully to prevent damage during shipment.**
Electronic components, such as printed circuit boards, should be placed in an antistatic bag before boxing. Daktronics does not recommend using packing peanuts when shipping.
- 4. Enclose:**
 - your name
 - address
 - phone number
 - the RMA number
 - a clear description of symptoms

Shipping Address

Daktronics Customer Service

RMA #

PO Box 5128

331 32nd Ave

Brookings, SD 57006

Fax: 605-697-4444

Daktronics Warranty and Limitation of Liability

The Daktronics Warranty and Limitation of Liability is located in **Appendix C**. The Warranty is independent of Extended Service agreements and is the authority in matters of service, repair, and display operation.

Section 9: Team Name Message Center Maintenance

IMPORTANT NOTES:

1. Disconnect power before doing any repair or maintenance work on the message centers.
2. Permit only qualified service personnel to access the internal electronics of the display.
3. Disconnect power when the scoreboard is not in use.

9.1 Team Name Message Center System Overview

Team name message centers (TNMCs) are available in two sizes: an 8 x 32 matrix model with four 8 x 8-pixel modules, and an 8x48 model comprised of six 8 x 8 modules. **Figure 15**, below, illustrates the larger unit. Light emitting diodes (LEDs) – tiny, solid-state lighting units – illuminate the displays.

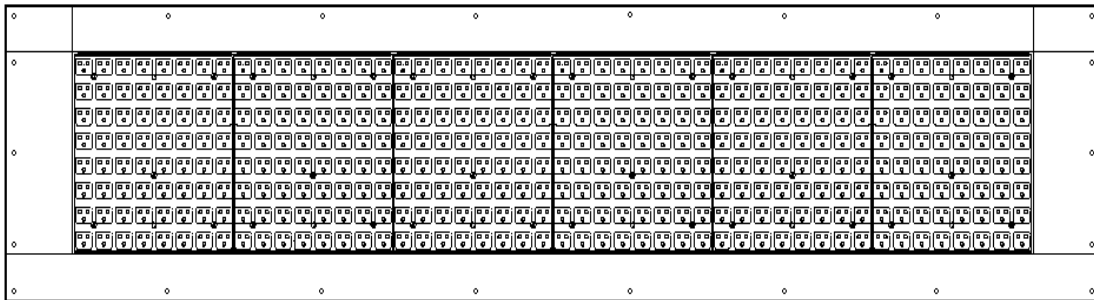

Figure 15: 8x48 Team Name Message Center

The message centers feature an array of red or amber LEDs, and are capable of displaying characters up to 10" high. Pixels in the red TNMC consist of a three-LED cluster, while amber TNMCs use four-LEDs per pixel.

The four-module TNMC measures approximately 1' - 4" tall by 4' wide, while the six-module TNMC measures approximately 1' - 4" by 6' wide; both have an in-cabinet depth of about 5". The smaller units weigh about 80 pounds per pair, and the larger TNMC sets add about 120 pounds to scoreboard weight.

TNMCs are typically installed in pairs. Although the message centers customarily are used for team names (home and guest), they are programmable and can display any type of caption. Characters are shown on a single line and either single- or double-stroke fonts may be used for the caption or name.

9.2 Maintenance and Troubleshooting Overview

Standard Daktronics outdoor LED scoreboards typically are front-accessible, but some models may be ordered with rear service access. For that reason, Daktronics team name

message centers have been designed so that they may be accessed from both the front *and* rear for easy maintenance and repair of internal components.

This section provides the following TNMC information:

- **Signal routing summary:** provides a basic explanation of signal travel through the TNMC display.
- **Power routing summary:** provides a basic explanation of power travel through the display.
- **Service and diagnostics:** provides instructions for removing various display components and explains the functions of circuit board connectors as well as the meanings of diagnostic LEDs.
- **Maintenance:** lists a number of steps to take to keep the team name message centers in safe, working order.
- **Troubleshooting:** lists possible display malfunctions and suggests a number of causes and corrections for each malfunction.
- **Replacement parts list:** includes the part description and number of display components that may have to be replaced during the life of this display.

9.3 Signal Summary

Reference Drawings:

Schematic, Amber TNMC, Gen IV	Drawing A-252645
Schematic, Red TNMC, Gen IV	Drawing A-252681
Component Locations; 832/848 Red/Amb Led TNMC, G-4.....	Drawing A-257029

Refer to your schematic, **Drawings A-252645 or A-252681**, for complete information on TNMC signal routing. **Drawing A-257029** indicates the locations of the internal electronic components. From signal input from the All Sport controller, routing can be summarized as follows:

1. Data from the display controller travels via cable harness into the scoreboard.
2. The signal then travels through the driver/power enclosure to the J1 connector on the current loop interface card.
3. Data exits at J42 via current loop harness, and connects with P43 at the TNMC controller assembly. An interconnect harness carries the signal to the first module, and the signal relays from module to module, in daisy-chain style, until it reaches the last module on the message center.

9.4 Power Summary

Reference Drawings:

Schematic, Amber TNMC, GEN IV	Drawing A-252645
Schematic, Red TNMC, Gen IV	Drawing A-252681
Component Locations; 832/848 Red/Amb Led TNMC, G-4	Drawing A-257029

Refer to your schematic, **Drawings A-252645 or A-252681**, for complete information on TNMC power routing. **Drawing A-187987 A-257029** indicates the locations of the internal electronic components. Note that amber TNMCs always contain two power supplies, while red TNMCs require only a single power supply.

Power routing for the display can be summarized as follows:

1. Incoming power terminates at the terminal block in the scoreboard driver enclosure. Using the same harness and J42-P43 connections as signal, power is then routed to the TNMC controller where it then travels to both the power supply assembly and to a transformer on the controller tray.
2. From the power supply assembly, power is relayed to the first module, and then from module to module.
3. While the modules draw their power directly from the power supply assemblies (6.5 V for red LED modules, 9 V for amber), the TNMC controller itself receives 16 V power from the transformer.

9.5 Service and Diagnostics

The following subsections address servicing of these display components:

- TNMC Controller
- Modules and Drivers
- Power Supplies

The subsections also address diagnostic LEDs and signal/power connectors found on the TNMC controller.

Remember: Disconnect power before servicing internal components!

TNMC Controller

Reference Drawings:

- 4 Column MASC LED Driver Specifications **Drawing A-166216**
- Component Locations; 832/848 Red/Amb LED TNMC, G4 **Drawing A-257029**

The TNMC controller, located on the rear-access panel, receives signal directly from the control console and sends data to the modules. Refer to the signal summary in **Section 9.3** for more information and to **Drawing A-257029** for the location of the controller board in the TNMC. The controller itself is detailed in **Drawing A-166216**, and **Figure 16** below illustrates a typical controller assembly. The card and transformer are mounted to a tray, which in turn is mounted to the back panel of the TNMC cabinet.

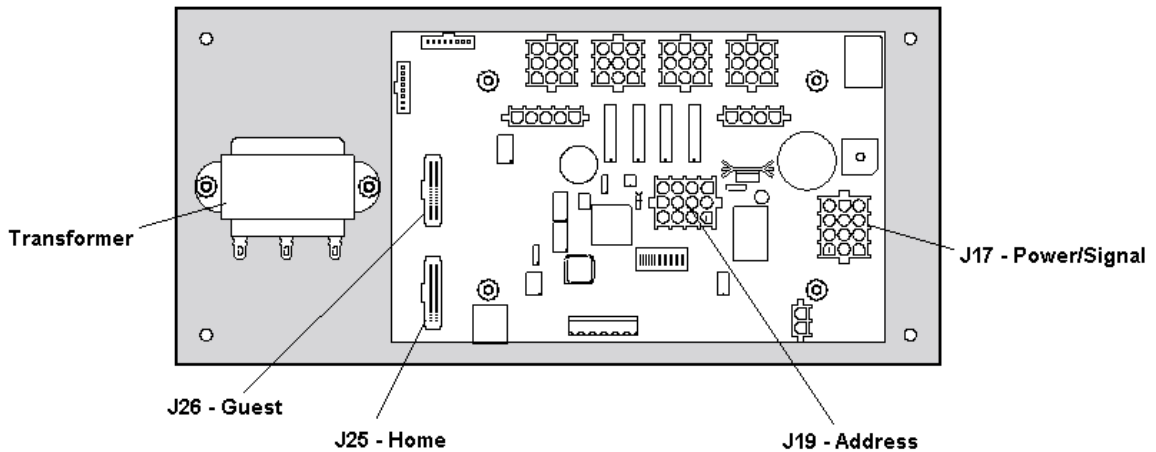

Figure 16: TNMC Controller Assembly

Note that connectors J25 and J26 control Home and Guest display. When the ribbon cable is plugged into J25, the TNMC sends home team information to the matrix display. In the opposite message center, the signal cable would be plugged into the J26 connector, and guest information would be displayed. (Switching the cables reverses the information each message center receives.)

J19 is the connector for the address plug. The address setting for TNMCs will always be 221. (There may be other settings if the TNMCs are used to display messages other than team names.)

Diagnostic LEDs

Reference Drawing:

4 Column MASC LED Driver Specifications.....**Drawing A-166216**

There are seven diagnostic LEDs located on the TNMC controller, six indicating when the controller is receiving signal, and the seventh indicating power status. Four of the LEDs, those indicating CAN and RS-232 signal functions, are not used with the TNMC controller.

The following table explains the operation and functions of each of the diagnostic LEDs.

LED	Color	Function	Operation	Summary
DS1	Red	CL signal RX	Steady on or blinking	DS1 will be on or blinking when the driver is receiving signal and off when there is no signal.
DS2	Green	CL signal TX	Steady on or blinking	DS2 will be on or blinking when the driver is transmitting and off when there is no signal.
DS3 (Not used with TNMC functions)	Red	CAN signal	Steady on or blinking	DS3 will be blinking when the driver is receiving signal and on when there is no signal with CAN (controller area network). If there is no CAN device connected to TB1, both DS3 and DS4 will be on and steady.
DS4 (Not used with TNMC functions)	Green	CAN signal	Steady on or blinking	DS4 will be blinking when the driver is receiving signal and on when there is no signal with CAN (controller area network). If there is no CAN device connected to TB1, both DS3 and DS4 will be on and steady.
DS5 (Not used with TNMC functions)	Red	RS-232 signal	Steady on or blinking	DS5 will be on or blinking when the driver is receiving signal and off when there is no signal with RS-232.

LED	Color	Function	Operation	Summary
DS6 (Not used with TNMC functions)	Green	RS-232 signal	Steady on or blinking	DS6 will be on or blinking when the driver is receiving signal and off when there is no signal with RS-232.
DS7	Green	Power	Steady on	DS7 will be on and steady indicating the driver has power.

Removing/Changing the Controller

Reference Drawings:

Component Locations; 832/848 Red/AMB LED, TNMC, G4 **Drawing A-257029**

Exploded Front View; Single Panel Module **Drawing B-126111**

Exploded Rear View; Single Panel Module..... **Drawing B-126112**

Drawing A-257029 indicates the location of the TNMC controller for each of the TNMC models. **Figure 17** below illustrates a typical TNMC layout. Complete the following steps to remove the controller from the display.

1. To access the controller from the front, unlatch the latch fasteners on the front face the LED module. Refer to **Drawings B-126111** and **B-126112**. (The fasteners are referred to as “latch plugs” on the drawings). One latch fastener is centered below the top row of pixels and one is centered above the bottom row. They may be slightly hidden by the louvers.

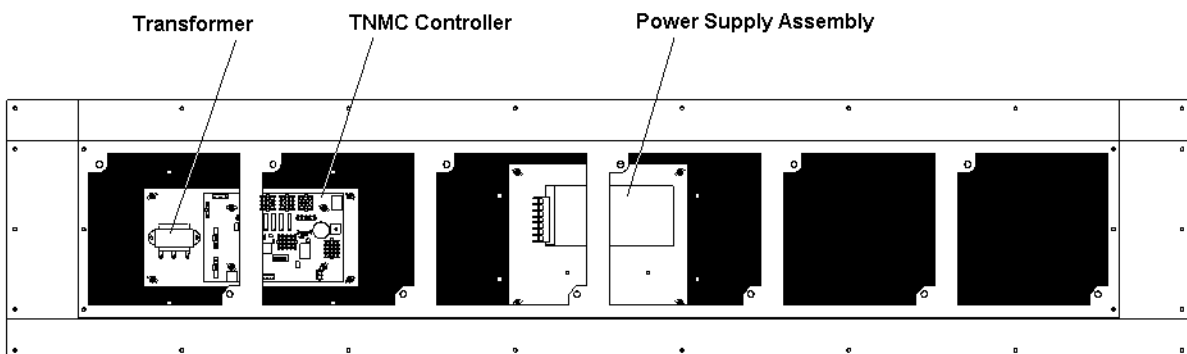

Figure 17: TNMC Internal Components (Modules Removed)

2. Using a $\frac{7}{32}$ " nut driver, turn each fastener a quarter-turn. Turn the top latch clockwise and the bottom latch counterclockwise. Carefully remove the module and detach the ribbon cables. It may be helpful to label the cables so you will know which cable goes to which connector when reattaching.

Note: To access the controller from the rear of the TNMC, as shown in **Figure 18**, remove the appropriate rear-access panel from the TNMC by loosening all four of the screws. Slide the access panel sideways to the larger part of the keyhole and carefully lift it off the TNMC. Take care not to drop the panel, and remember that the module controller is attached to the panel.

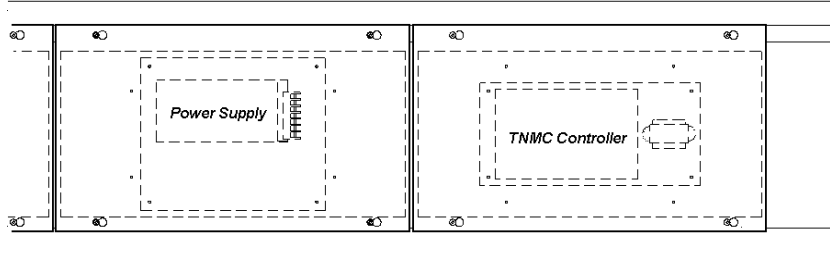

Figure 18: TNMC Rear Access

3. Disconnect power from J17
4. Remove all power and signal connections from the board. Release “locked” connectors by squeezing together the tabs, and then carefully pulling them from the jack. Label the cables, indicating which cable was removed from which connector; the labeling will be helpful when you replace the board.
5. Remove the four nuts holding the board in place.
6. Follow the previous steps in reverse order to install a new controller board.

Modules and Drivers

Reference Drawings: (for displays installed Prior to 11/29/05)

Exploded Front View; Single Panel Module	Drawing B-126111
Exploded Rear View; Single Panel Module.....	Drawing B-126112

The module and driver board are a single, functional unit. To remove a module, complete the following steps:

1. The modules are attached to an internal frame called the module mounting panel. Find the latch-access fasteners (referred to as "latch plugs" on the drawings) on the front of the module. One is centered below the top row of pixels and one is centered above the bottom row. (They may be slightly hidden by the louvers.)
2. Unlatch the latch fasteners, illustrated in **Figure 19**, by turning them a quarter-turn using a $\frac{7}{32}$ " nut driver. Turn the top latch clockwise and the bottom latch counterclockwise. Carefully remove the module and detach the ribbon cables. Label the cables, indicating which cable was removed from which connector; the labeling will be helpful when you replace the board.

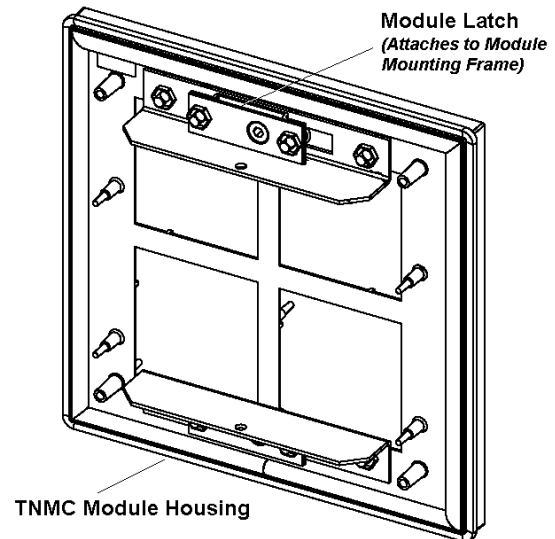

Figure 19: TNMC Module (Rear View)

Note: If you are accessing the unit from the rear, follow this procedure: First, remove the rear access panel (explained in preceding subsection.): While holding onto the module, push it out and turn it in such a manner (generally a sideways, diagonal turn) that it will fit through the frame opening; then pull the module back through the opening in the frame. Carefully disconnect the ribbon cables. Once again, label the cables, indicating which cable was removed from which connector; the labeling will be helpful when reconnecting.

When installing a module, reverse the previous steps and take note of the following points:

- Weatherstripping on the back edge of the module must be intact and in good condition to prevent water from seeping into the display.
- Module latches must be fully engaged to create a watertight seal around the edge of the module. The module should be firmly seated against the display when the latches are fully engaged.

Each module assembly contains a module housing (containing LEDs and the driver board) and a louver assembly. **Drawings B-126111** and **B-126112** illustrate the various module components.

Individual components such as louvers can be removed for service, but Daktronics recommends that the module be kept intact and that the entire assembly be sent in for repair or replacement.

For displays installed after 11/29/05

The module and driver are a single functional unit. Each module assembly is made up of a module housing (containing LEDs and the driver) and a louver assembly.

1. Locate the latch access fasteners on the module (one is centered below the second row of pixels and one is centered above the bottom two rows)
2. With a 1/8" hex wrench, turn both latch access fasteners a quarter turn counter-clockwise to open as shown in **Figure 20** – and the clockwise to close.
3. Gently pull the module far enough forward to reach behind the back and disconnect the power and ribbon cables

When installing a module, reverse the previous steps and take note of the following points.

- The weather-stripping on the back edge of the module must be intact and in good condition if it is to prevent water from seeping into the display.
- The module latches must be fully engaged to create a watertight seal around the edge of the module. The module should be firmly seated against the display when the latches are fully engaged.

Power Supplies

Reference Drawings:

Schematic, Amber TNMC, GEN IV	Drawing A-252645
Schematic, Red TNMC, GEN IV	Drawing A-252681

The red-LED TNMC uses a single power supply assembly to power all modules in the 8x32 and 8x48 models. The amber TNMC uses a dual power supply assembly to power all modules in the 8x32 or 8x48 models. Refer to **Drawings A-252645 or A-252681**.

Removing/Changing a Power Supply

Complete the following steps to remove a power supply from the display:

1. See the directions in the preceding **Module and Drivers** subsection for information on how to access the component from the front or rear.
2. Disconnect all the wires connected to the power supply.
3. Remove the hardware holding the power supply in place to free the unit.
4. Follow these steps in reverse order to install a new power supply.



Figure 20: Removing a Module

Weatherstripping

To ensure that the display is waterproof, weatherstripping has been installed around the entire display and around each module. It is important that the weatherstripping is attached properly at all times, or water may leak into the display and damage the components.

9.6 TNMC Display Maintenance

Complete a yearly inspection to maintain safe and dependable display operation. This inspection should address the following issues:

- **Loose Hardware**
Verify that fasteners, such as bolts and rivets, have not come loose. Check and tighten or replace fasteners as required.
- **Excessive Dust Buildup**
Occasionally, it may be necessary to vacuum the inside of the display cabinet to remove dust/dirt buildup that may interfere with airflow.
- **Water Intrusion - Water stain marks**
Water can enter the display where weatherstripping has come loose or deteriorated; where fasteners have come loose, allowing gaps in the panels; or where moisture may be entering around hardware. Check electronic components for corrosion.
- **Corrosion**
Check the paint, and look for possible corrosion, especially at footings, structural tie points, and ground rods and other types of grounding electrodes.

Note: If you notice any of the preceding conditions, make repairs or take corrective action immediately.

9.7 Troubleshooting

This subsection contains some symptoms that may be encountered in the displays. This list does not include every possible symptom, but does represent common situations that may occur.

Symptom/Condition	Possible Cause/Remedy
One or more LEDs on a single module fails to light.	<ul style="list-style-type: none"> ▪ Check/replace the ribbon cables on the module. ▪ Replace the module.
One or more LEDs on a single module fails to turn off.	<ul style="list-style-type: none"> ▪ Check/replace the ribbon cables on module. ▪ Replace the module.
A section of the display is not working; the section extends all the way to the right side of the display.	<ul style="list-style-type: none"> ▪ Replace the first module/driver on the left side of the first module that is not working. ▪ Replace the second module that is not working. ▪ Replace the power supply assembly on the first module that is not working. ▪ Replace the ribbon cable.
One row of modules does not work or is garbled.	<ul style="list-style-type: none"> ▪ Replace the first module. ▪ Replace the controller.
A group of modules that share the same power supply assembly fails to work.	<ul style="list-style-type: none"> ▪ Replace the power supply assembly.
Entire display fails to work.	<ul style="list-style-type: none"> ▪ Check for proper line voltage into the power termination panel. ▪ Check/replace the ribbon cable from the controller to the modules. ▪ Check the voltage settings on the power supplies. ▪ Check/replace the signal cable to the controller. ▪ Replace the controller.

9.8 Initialization Information at Startup

Every time the display is powered up, the display will run through an initialization during which it will test all LEDs and addresses. First, the message center will display the proper address number. When completed, the initialization test will display Home and Guest in the appropriate location. If the entire TNMC display fails at startup, signal may not be properly connected, or the address plug may not be connected to the J17 jack on the TNMC controller card. Check both connections in the event of a failure.

9.9 Replacement Parts List

The following table contains some of the TNMC components that may have to be replaced over the life of a display. Many of the components within the display itself also have attached part number labels.

Part Description	Part Number
Controller assy; 832/848, LED TNMC, G3	0A-1152-2549
▪ Driver (only); MASC, 4-col, LED, coated	0A-1192-0068
▪ Transformer; 115/230 V pri, 16 V sec @ 2 A	T-1063
Module, TNMC; amber LED (4A, 8x8, coated, Type 2)	0A-1208-4001
Module, TNMC; red LED (3R, 8x8, coated, Type 2)	0A-1208-4000
Power supply assy; amber LED TNMC	0A-1192-3161
Power supply (only); amber LED TNMC	A-1591
Power supply assy; red LED TNMC	0A-1192-3160
▪ Power supply (only); red LED TNMC	0A-1192-3160
Cable assy; 20-pos ribbon, 18", dual row (module to module)	0A-1192-3160
Cable assy; 20-pos ribbon, 30" (TNMC controller to first module)	0A-1192-3160
Electrical contact cleaner/lubricant (CaiLube®)	0A-1192-3160

*Effective in Fall 2003, Daktronics Part Number 0A-1208-3005 was replaced with Part Number 0A-1208-3018. Contact Daktronics Customer Service for specific replacement part numbers.

Part numbers for each complete team name message center assembly are as follows:

Assembly	Part Number
F. ASSY; 832 RED LED TNMC, G4	0A-1192-3164
F. ASSY ; 832 AMB LED TNMC, G4	0A-1192-3165
F. ASSY ; 848 RED LED TNMC, G4	0A-1192-3166
F. ASSY ; 848 AMB LED TNMC, G4	0A-1192-3167

To prevent theft, Daktronics recommends purchasing a lockable cabinet to store manuals and replacement and spare parts.

Refer to **Section 8.9** for information on the Daktronics Exchange and Repair and Return programs.

Section 10: Scoreboard Options

The following options are available for the Daktronics single-section scoreboards to make them more adaptable to individual scoring and timing needs:

- Team name caption kits for certain models
- Trumpet horn for football and soccer
- Radio control
- Portable power pack

10.1 Changeable Team Name Captions

Reference Drawing:

Caption Changing **Drawing A-44549**

The team name caption kit contains hardware for one caption only and consists of an upper caption retainer, a lower caption retainer, a changeable caption panel and screws. The standard HOME and GUEST captions are applied directly to the face of the scoreboard. Team name captions are on changeable panels that fit into retainers mounted above and below the HOME and GUEST captions. If retainers are not already present on your scoreboard, attach the retainers included with the caption kit as shown on **Drawing A-44549**.

To install a changeable panel:

1. Insert the top of the panel into the upper retainer.
2. Lift the panel all the way up into the retainer.
3. Insert the bottom of the panel into the lower retainer.

Reverse this procedure to remove the caption panel.

An optional caption changer is available for installing and removing panels from the ground. Each caption panel is punched with keyholes. Screw heads on the crossbar of the caption changer fit into the keyholes. The caption changer pole is extendable, with a ring tightener to adjust the length. Loosen the ring to extend the pole to the desired length; tighten the ring for pole use.

CAUTION
<p>Note: The aluminum caption changer can conduct electricity. Do not use it within 20-feet of power lines.</p> <p>Be careful when using the caption changer in high or gusting winds. Wind may catch the panel and unhook it from the changer. The surface area of the caption panel could also act as a sail, making it difficult to maintain a grip on the pole. Hold the pole tightly, and be careful to maintain your balance when using the caption changer in windy situations.</p>

10.2 Trumpet Horn

Trumpet horn options are available for installation only on scoreboards that have clocks. There are two types of trumpet horns:

- Internally mounted 120 V trumpet horn
- Externally mounted 12 V DC trumpet horn

For additional information on the Trumpet Horn please refer to the **Trumpet Horn: Installation Manual**, [ED-10006](#).

Reference Drawings:

Schematic, Outdoor SCBD 12 V DC Trumpet Horn AS5K	Drawing A-128938
Schematic; 120 V AC Trumpet Horn	Drawing A-132173
120 V DC Horn Mounting	Drawing A-162100
F.ASSY; LED, 12V DC Horn Mounting	Drawing B-242731

Trumpet Horn Part Numbers

Part Description	Part Number	Typical Model Usage
120 V AC Trumpet Horn Bottom Extrusion Mounting, See Drawing A-162100 Left most illustration	0A-1091-0469	BA-718, FB-824, FB-2005, FB-2410, MS-915, MS-918, MS-2002, MS-2003, MS- 2004, MS-2006, MS-2011, MS-2012, SO-918, SO-2008, SO-2013
Note: 0A-1192-1112 is also a 120 VAC horn assembly, but is not mountable for the products listed above.		
12 V DC Trumpet Horn, AS5000; Outdoor See Drawing A-242731 for mounting details	0A-1091-1213	TI-2019 & All models listed above
Compact 12 V DC Horn Assy.	0A-1192-0093	TI-2010, TI-2012, TI-2015

10.3 Radio Control

Radio control is an option with all Daktronics outdoor LED scoreboards, the system providing scoreboard control via a 2.4 GHz, extra-high frequency FM signal.

The radio transmitter and receiver are not standard equipment. This setup requires a control console such as the All Sport, equipped with radio output. The display receives control signal via a radio receiver mounted internally to the front panel. The receiver plugs into the power terminal block in the driver/power enclosure.

For additional information about this option, contact your Daktronics representative; for complete information on radio communications, refer to the All Sport 5000 Series Control Console Operation Manuals, [ED-11976](#).

10.4 Portable Power Pack

Reference Drawing:

Installation, Portable Powered Scoreboards**Drawing A-166787**

Another option is the portable power pack, which permits operation of the scoreboard via battery. The power pack, self-contained and mounted on a wheeled cart, includes batteries, charger, and a 120 V AC power inverter. Refer to Drawing **A-166787** for information on installation procedures.

Appendix A: Reference Drawings

A Drawings

Segmentation, 7 Segment Bar Digit	Drawing A-38532
Display Mounting	Drawing A-44412
Lifting Scoreboard	Drawing A-44548
Caption Changing.....	Drawing A-44549
Ad Panel Mounting	Drawing A-52187
Assembly, Ad Panel, BA-515	Drawing A-52585
Ad Panel Mounting, BA-518	Drawing A-52811
Installation Specifications, BA-515.....	Drawing A-55003
Installation Specifications, BA-518.....	Drawing A-55004
Installation Specifications, BA-718.....	Drawing A-55005
Installation Specifications, BA-618 & SO-2013.....	Drawing A-55006
Installation Specifications, BA-624.....	Drawing A-55007
Installation Specifications, MS-918	Drawing A-55009
Installation Specs, SO-918, SO-2009 and SO-2010.....	Drawing A-55010
Scoreboard Mounting	Drawing A-55101
Lifting Small Baseball Scoreboard	Drawing A-58668
Installation Specifications, BA-1018, BA-2016, BA-2017.....	Drawing A-61904
Installation Specifications, MS-915	Drawing A-113568
Address Table, 1 Through 128.....	Drawing A-115078
Installation Specifications; MS-2002	Drawing A-127195
Installation Specifications, FB-824 & SO-824	Drawing A-127287
Schematic, Outdoor Scbd 12VDC Trumpet Horn, AS5K.....	Drawing A-128938
Schematic; 120VAC Trumpet Horn	Drawing A-132173
Installation Specifications; MS-2011 w/TNMC	Drawing A-135414
Installation Specifications, MS-2006	Drawing A-135575
Single Section LED Scoreboard Models	Drawing A-142912
Installation Specifications; SO-2008.....	Drawing A-149074
Installation Specifications; BA-2004/2005/2011.....	Drawing A-152777
Installation Specifications; MS-2012	Drawing A-152790
Single Section LED Scoreboard Models	Drawing A-152950
Installation Specifications, BA-2003.....	Drawing A-158322
Horn Mounting; 120 V DC	Drawing A-162100
Installation Specifications; FB-2005-11	Drawing A-162886
Schematic, Multipurpose LED DRVR.....	Drawing A-165028
4 Column MASC LED Driver Specifications.....	Drawing A-166216
Installation, Portable Powered Scoreboards	Drawing A-166787
Installation Specifications; TI-2003.....	Drawing A-169367
Installation Specifications; TI-218.....	Drawing A-169376
Installation Specs; TI-418/RO-2011/CT-2001/TI-2019.....	Drawing A-169380
Installation Specs; TI-2015.....	Drawing A-173484
Installation Specifications	Drawing A-176286
Component Locations; BA-515-11/-21, G3.....	Drawing A-178600
Component Locations; BA-518-11/-21, G3.....	Drawing A-178696
Component Locations; BA-718-11/-21, G3.....	Drawing A-178784

Installation Specifications, BA-2010.....	Drawing A-179304
Schematic; Gen III, OD LED, 3 DRVR Display.....	Drawing A-179541
Schematic; Gen III, OD LED, 1 DRV w/TNMC	Drawing A-179790
Schematic; Gen III, OD LED, 3 DRV w/TNMC	Drawing A-180081
Component Locations; BA-2003-11/-21, G3.....	Drawing A-180362
Component Locations; MS-915-11/-21, G3	Drawing A-180365
Schematic; Gen III, O.D. LED, 2 DRVR Display	Drawing A-180637
Component Locations; SO-918-11/-21, G3	Drawing A-180835
Component Locations; TI-418-11/-21, G3	Drawing A-181177
Component Locations; TI-218-11/-21, G3	Drawing A-181701
Component Locations; TI-2012-11/-21, G3	Drawing A-182081
Component Locations; TI-2019-11/-21, G3	Drawing A-182090
Component Locations; TI-2010-11/-21, G3	Drawing A-182110
Component Locations; TI-2015-11/-21, G3	Drawing A-182176
Component Locations; RO-2010-11/-21, G3.....	Drawing A-182293
Component Locations; RO-2011-11/-21, G3.....	Drawing A-182296
Component Locations; FB-824-11/-21, G3.....	Drawing A-182543
Component Locations; TI-2003-11/-21, G3	Drawing A-182702
Scoreboard MTG; Scoreboard with Spacers	Drawing A-182909
Installation Specs; RO-2010	Drawing A-185216
Installation Specifications; TI-2012	Drawing A-185698
Component Locations; 832/842 Red/AMB LED TNMC, G3.....	Drawing A-187987
Component Locations; MS-2006-11/-21, G3	Drawing A-189213
Component Locations; MS-2003-11/-21, G3.....	Drawing A-189593
Installation Specifications; MS-2003.....	Drawing A-191730
Component Location; MS-2011-11/-21, G3.....	Drawing A-193823
60" Digit ASSY	Drawing A-197586
Component Locations, TI-215-11/-21, G3	Drawing A-201607
Installation Specifications, TI-215	Drawing A-201655
Installation Specifications; BA-518.....	Drawing A-211376
Component Locations; BA-1018-11/21, G3.....	Drawing A-227184
Component Locations; BA-624-11/21, G3.....	Drawing A-227767
Component Locations; MS-918-11/21 G3	Drawing A-227840
Component Locations; BA-618-11/21, G3.....	Drawing A-227949
Component Locations; FB-2005-11/21, G3	Drawing A-228192
Component Locations; SO-2013-11/21, G3	Drawing A-228598
Component Locations; BA-2004-11/21, G3.....	Drawing A-228668
Component Locations; MS-2011-11/21, G3	Drawing A-229459
Component Locations; MS-2004-11/21, G3	Drawing A-229758
Harness Assembly Diagram; 60" Digit.....	Drawing A-232925
Installation Specifications; BA-2019-11/12	Drawing A-233487
Component Locations; BA-2005-11/21	Drawing A-234592
Component Locations; CR-2002.....	Drawing A-235279
Installation Specifications; CR-2002	Drawing A-235517
Component Locations; MS-2002-11/21, G3	Drawing A-235932
Component Locations; TI-2024-11/21, 36", Dog Clock	Drawing A-236131
Installation Specifications; TI-2024	Drawing A-236147
Component Location; SO-2008-11/21, G3, FD	Drawing A-236233
Component Locations; BA-2010-11/21, G3.....	Drawing A-237102
Component Locations; BA-2011-11/21, G3.....	Drawing A-237108

Component Locations; BA-2014-11/21, G3	Drawing A-237118
Component Locations; BA-2016-11/21, G3	Drawing A-237124
Component Locations, BA-2017-11/12, FD, G3	Drawing A-239729
Component Locations, MS-2012-11/12, FD.....	Drawing A-246786
Component Locations, CR-2003-11/12.....	Drawing A-248722
Installation Specification, CR-2003	Drawing A-248966
Schematic; Amber TNMC GEN IV	Drawing A-252645
Schematic; Red TNMC GEN IV	Drawing A-252681
Component Locations; 832/842 RED/AMB LED TNMC, G4	Drawing A-257029
Components Locations; BA-2019-11/21	Drawing A-260481
Schematic; 60" LED Clock.....	Drawing A-273885
Component Location; FB-2410	Drawing A-274863
Driver; GEN IV Outdoor LED, 16 Col Master	Drawing A-284920
Driver; GEN IV Outdoor LED, 8 Col Master	Drawing A-284922
Schematic; GEN IV Outdoor LED, 16 Col Driver	Drawing A-285779
Schematic; GEN IV Outdoor LED 8 Col. Driver ASSY.....	Drawing A-285881
Specifications; LED Driver IV, 16 Col.....	Drawing A-288137
Specifications; LED Driver IV, 8 Col.....	Drawing A-288138
Address Table 1; GEN IV Driver Address Dip Switch	Drawing A-290261
Component Location; BA-2023	Drawing A-331219
Schematic: 240V GEN IV Outdoor LED- 16 COL Driver.....	Drawing A-324504
Component Location; BA-2022-11/-21, G4.....	Drawing A-329456
Component Locations; CT-2001-11/-21, G4	Drawing A-578903
Component Location; BA-2024-11/-21, G4.....	Drawing A-825868

B Drawings

Exploded Front View; Single Panel Module	Drawing B-126111
Exploded Rear View, Single Panel Module.....	Drawing B-126112
Digit Assemblies; Gen III LED Digits	Drawing B-177679
Enclosed Driver, 4-Col MASC	Drawing B-179349
Schematic; Baseball w/S.O.P., GEN III, Optional TNMC.....	Drawing B-204264
Schematic, Baseball w/ S.O.P GEN IV, Optional TNMC	Drawing B-204725
Schematic; Gen III & IV OD LED, 1DRVR W/S.O.P	Drawing B-210454
F.ASSY; LED, 12V DC Horn Mounting	Drawing B-242731
F. ASSY; BA-2023-11/-21, G4.....	Drawing B-331009

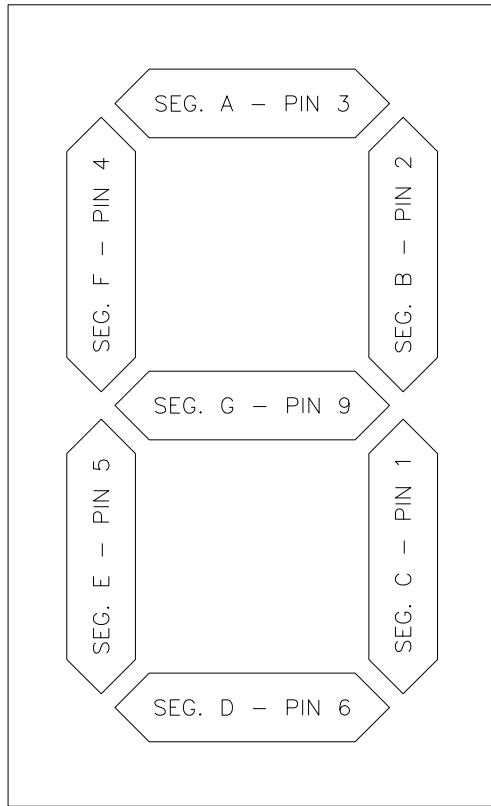

7 SEGMENT BAR DIGIT
FRONT VIEW

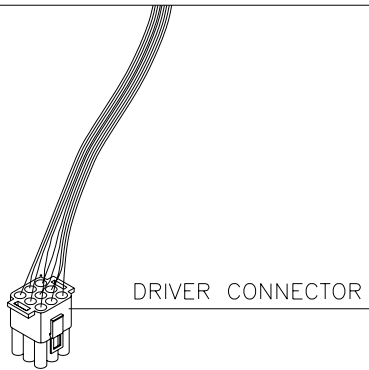

COLOR CODE		
PIN NO.	WIRE COLOR	DRIVER SEGMENT
1	ORN	C
2	RED	B
3	BRN	A
4	BLU	F
5	PNK	E
6	TAN	D
7	BLK	COM.
8	GRY	H
9	VIO	G

CONNECTOR PIN NUMBERING
NOTE SPLINE NEAR NO. 1

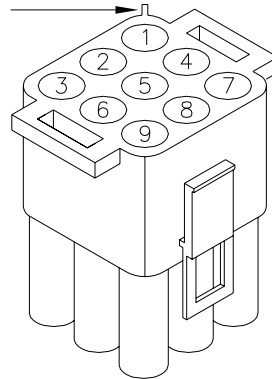

NOTE: "H" SEGMENT, GRAY WIRE IS NOT USED ON 7 SEGMENT BAR DIGIT.

THE CONCEPTS EXPRESSED AND DETAILS SHOWN ON THIS DRAWING ARE CONFIDENTIAL AND PROPRIETARY. DO NOT REPRODUCE BY ANY MEANS, INCLUDING ELECTRONICALLY WITHOUT THE EXPRESSED WRITTEN CONSENT OF DAKTRONICS, INC. COPYRIGHT 2003 DAKTRONICS, INC.

DAKTRONICS, INC. BROOKINGS, SD 57006

PROJ: BASKETBALL
TITLE: SEGMENTATION, 7 SEGMENT BAR DIGIT
DES. BY: HEIDERSCHIEDT DATE: 5 JUN 89

REVISION 02 APPR. BY: AVB SCALE: 1=4 1009-R04A-38532

REV.	DATE	DESCRIPTION	BY	APPR.
2	30 APR 97	ADDED SEGMENT DESIGNATIONS TO DIGIT FIGURE.	AVB	AVB
1	2 JAN 92	CHANGED FROM B-SIZE TO A-SIZE DWG.	C FICK	

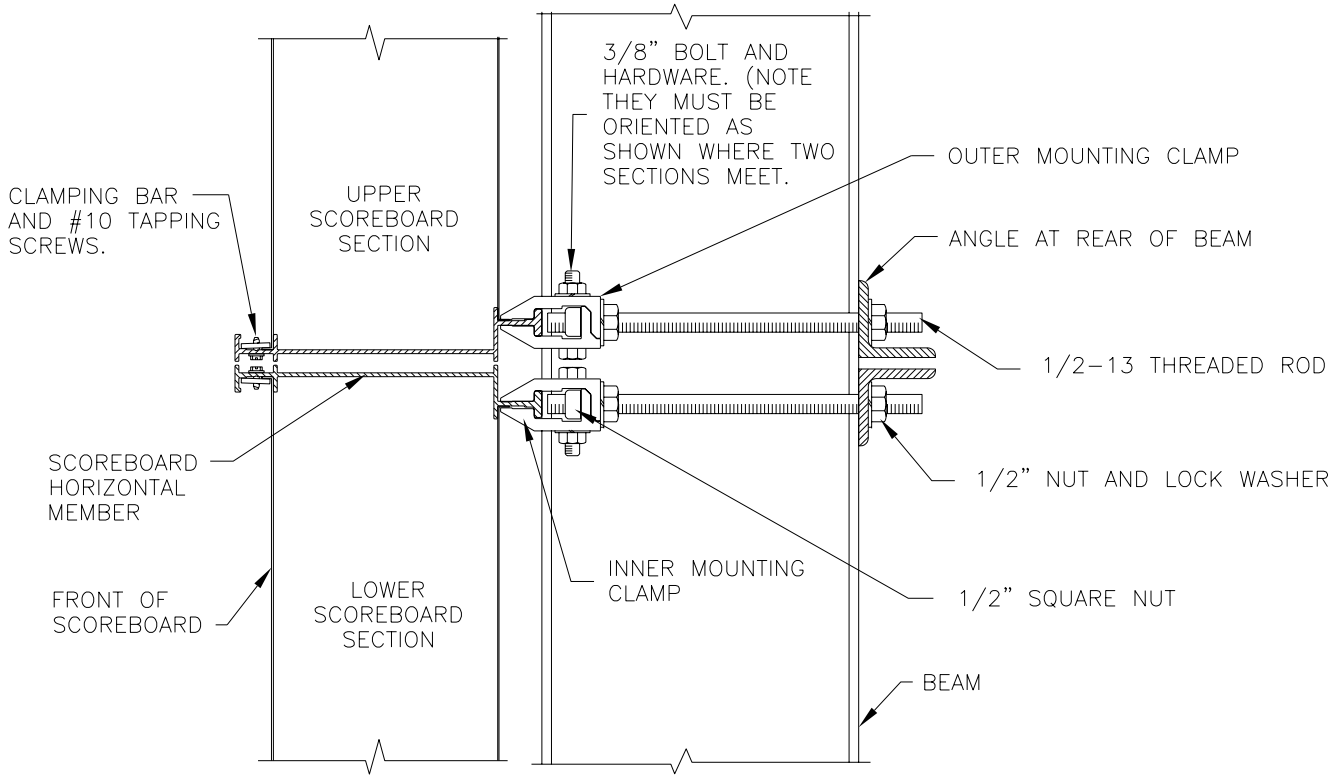

SIDE VIEW

NOTE: CLAMPING BARS AND HARDWARE MAY HAVE TO BE REMOVED IN ORDER TO INSTALL THE INNER AND OUTER MOUNTING CLAMPS.

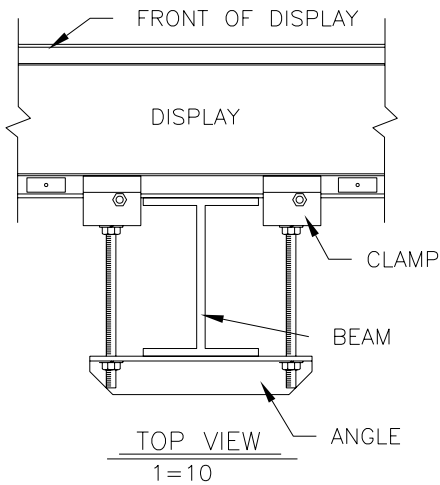

- THREADED RODS RUN ALONG BOTH SIDES OF BEAM.
- THEY DO NOT PASS THROUGH THE FLANGES OF THE BEAM.
- NO DRILLING IS NECESSARY.

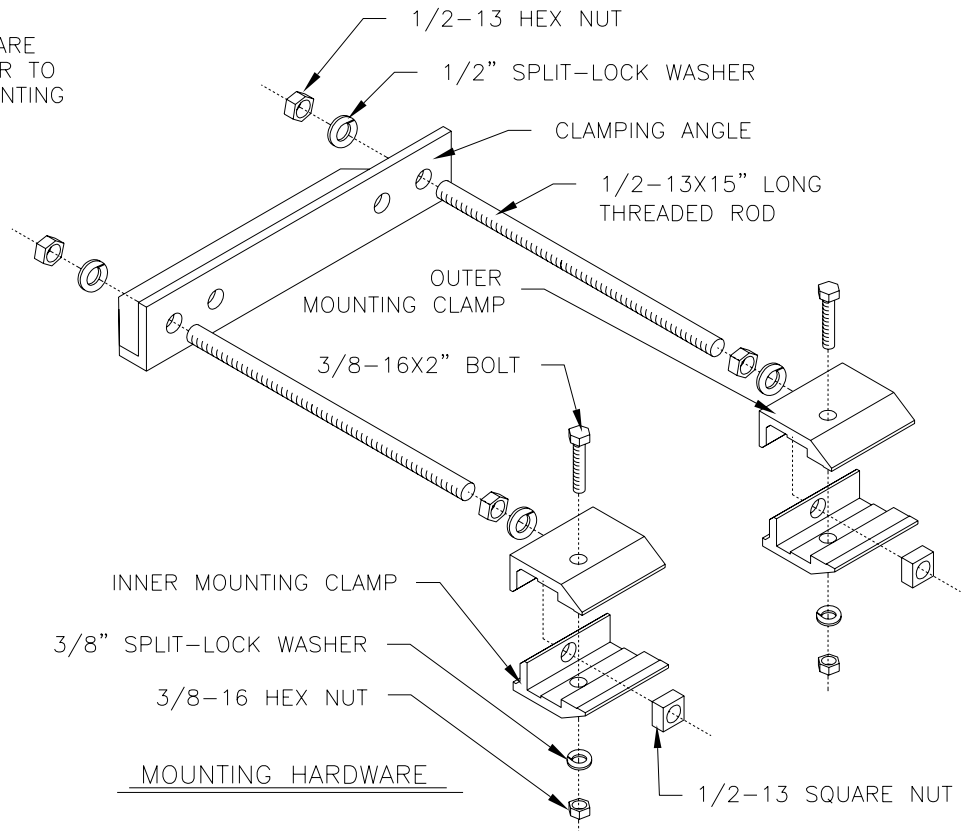

DAKTRONICS, INC. BROOKINGS, SD 57006

PROJ: OUTDOOR SCOREBOARDS

TITLE: DISPLAY MOUNTING

DES. BY: JHEIDER

DRAWN BY: JHEIDER

DATE: 29 AUG 90

REVISION

APPR. BY:

00

SCALE: 1=5

1091-R10A-44412

REV.	DATE	DESCRIPTION	BY	APPR.

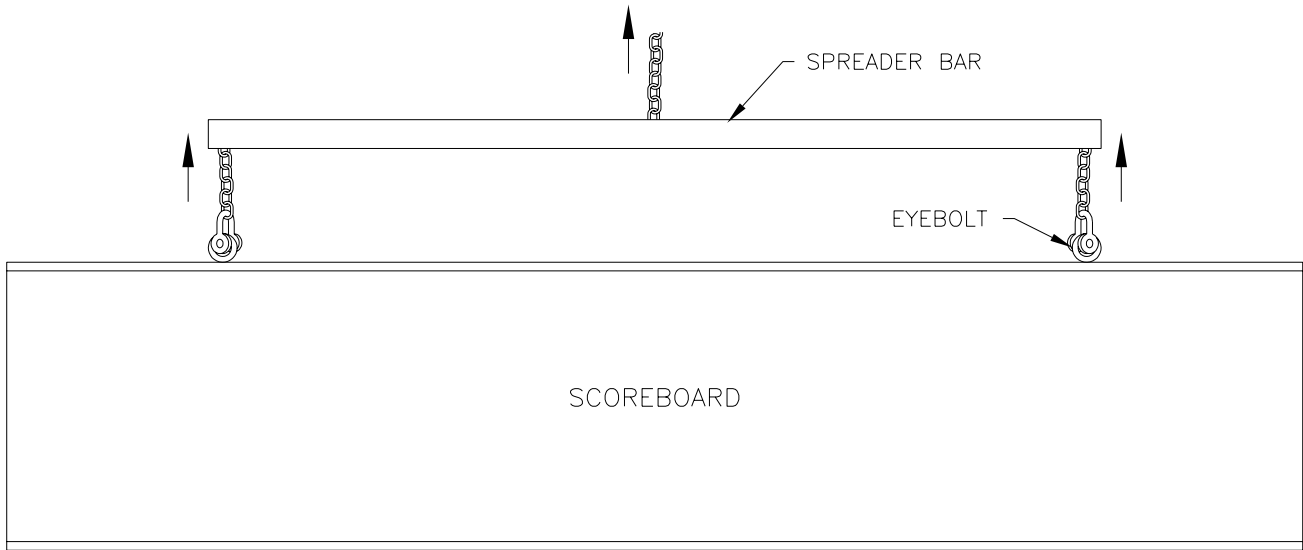

PREFERRED LIFTING METHOD

USE A SPREADER BAR SO THAT THE FORCE ON THE EYEBOLTS IS STRAIGHT UP.

ALTERNATE LIFTING METHOD

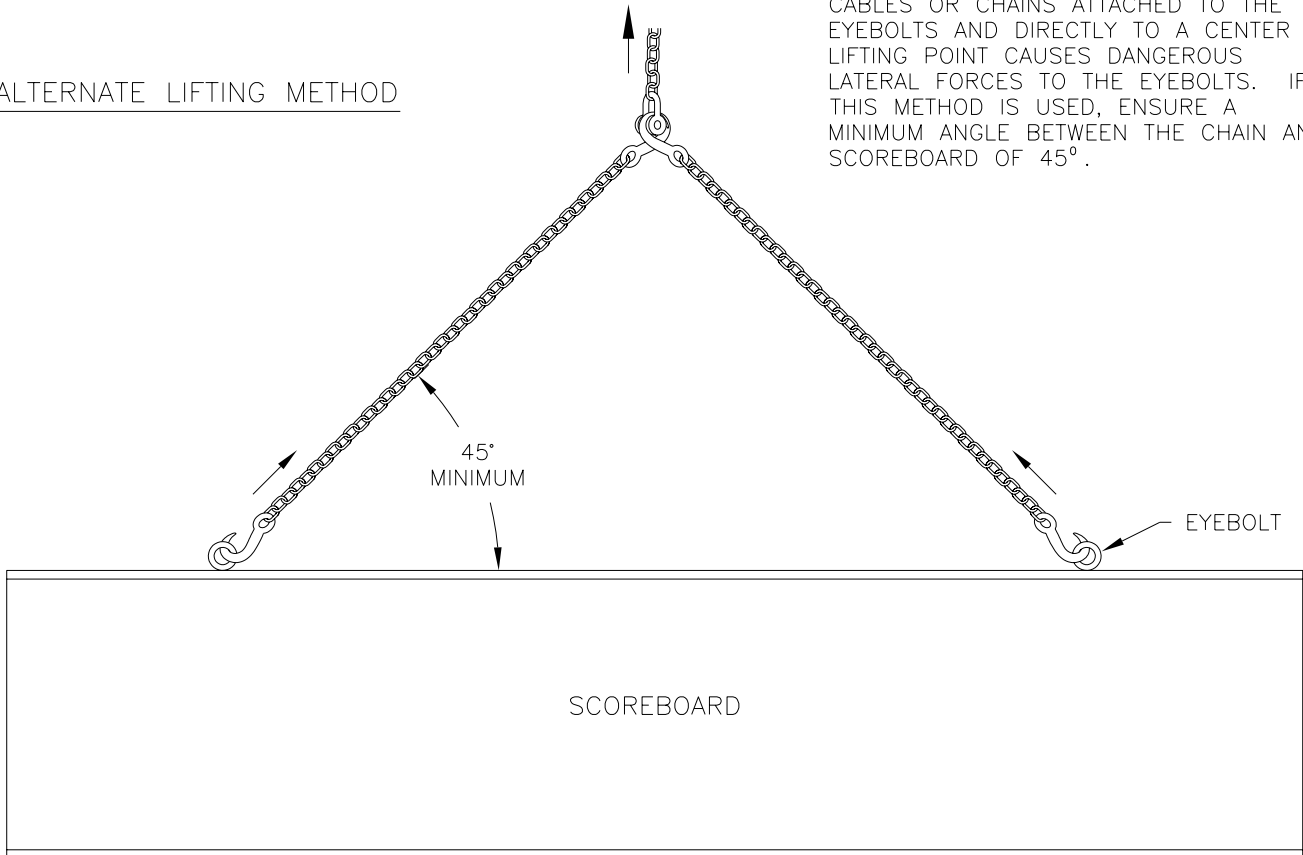

CABLES OR CHAINS ATTACHED TO THE EYEBOLTS AND DIRECTLY TO A CENTER LIFTING POINT CAUSES DANGEROUS LATERAL FORCES TO THE EYEBOLTS. IF THIS METHOD IS USED, ENSURE A MINIMUM ANGLE BETWEEN THE CHAIN AND SCOREBOARD OF 45°.

THE CONCEPTS EXPRESSED AND DETAILS SHOWN ON THIS DRAWING ARE CONFIDENTIAL AND PROPRIETARY. DO NOT REPRODUCE BY ANY MEANS, INCLUDING ELECTRONICALLY WITHOUT THE EXPRESSED WRITTEN CONSENT OF DAKTRONICS, INC. COPYRIGHT 2005 DAKTRONICS, INC.

DAKTRONICS, INC. BROOKINGS, SD 57006

PROJ: OUTDOOR SCOREBOARDS

TITLE: LIFTING SCOREBOARD

DES. BY:

DRAWN BY: AVB

DATE: 12SEP90

REVISION

APPR. BY:

01

SCALE: NONE

1091-R10A-44548

REV.	DATE	DESCRIPTION	BY	APPR.
01	17 MAY 01	ADDED MINIMUM ANGLE TO ALTERNATE LIFTING METHOD; CHANGED CORRECT TO PREFERRED METHOD AND WRONG TO ALTERNATE METHOD	TWEBER	

IF CAPTION GUIDES (RETAINERS) ARE NOT ALREADY ATTACHED TO SCOREBOARD, USE THE SCREWS PROVIDED WITH THE GUIDES (RETAINERS) TO ATTACH THEM AS SHOWN.

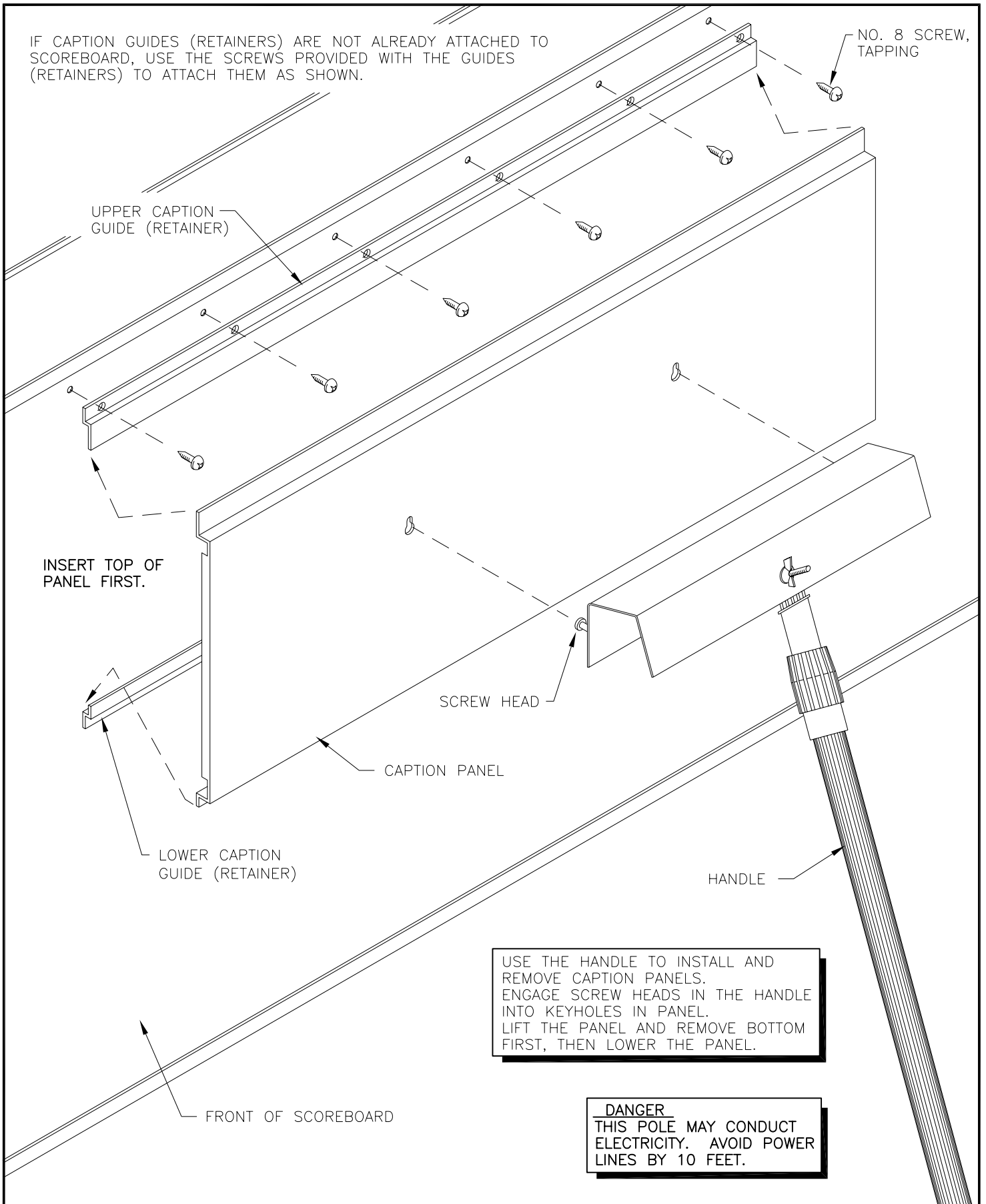

USE THE HANDLE TO INSTALL AND REMOVE CAPTION PANELS. ENGAGE SCREW HEADS IN THE HANDLE INTO KEYHOLES IN PANEL. LIFT THE PANEL AND REMOVE BOTTOM FIRST, THEN LOWER THE PANEL.

DANGER
THIS POLE MAY CONDUCT ELECTRICITY. AVOID POWER LINES BY 10 FEET.

DAKTRONICS, INC. BROOKINGS, SD 57006	
PROJ: OUTDOOR SCOREBOARDS	
TITLE: CAPTION CHANGING	
DES. BY:	DRAWN BY: AVB
	DATE: 19SEP90
REVISION	APPR. BY:
	SCALE: NONE
1091-E10A-44549	

1	22AUG91	CORRECTED CAPTION CHANGER ILLUSTRATION TO REFLECT ACTUAL DEVICE.	JLH	
REV.	DATE	DESCRIPTION	BY	APPR.

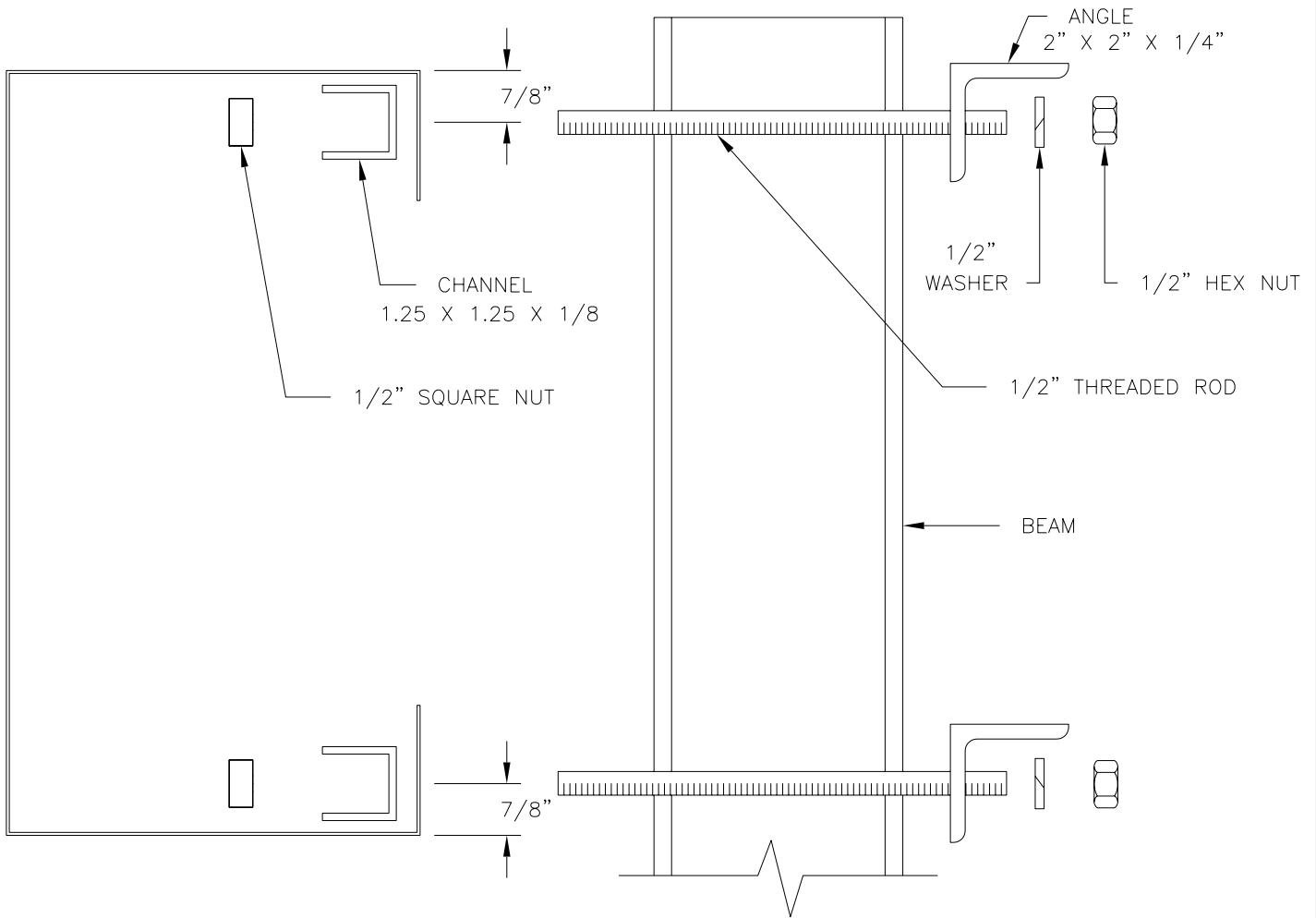

MOUNTING INSTRUCTIONS:

1. USE THE MOUNTING CHANNEL TO DETERMINE WHICH HOLE COMBINATION SHOULD BE USED. BE SURE TO KEEP THE BOLTS AS CLOSE TO THE BEAM AS POSSIBLE.
2. USING THE MOUNTING CHANNEL AS A TEMPLATE, DRILL 9/16" HOLES IN THE UPPER AND LOWER REAR FLANGE OF AD PANEL WHERE THE SUPPORTS WILL GO.
3. PLACE SQUARE NUTS INSIDE CHANNEL AND THREAD BOLTS THROUGH.
4. LIFT AD PANEL INTO POSITION WITH BOLTS STILL IN PLACE.
5. PLACE MOUNTING ANGLES OVER EACH PAIR OF BOLTS AND SECURE WITH LOCK WASHERS AND HEX NUTS.
6. WHEN PANEL IS ADJUSTED TO FINAL DESIRED POSITION, TIGHTEN HEX NUTS FIRMLY.

MOUNTING INSTRUCTIONS: FOR AD PANELS WITH BACKSHEETS.

1. USE THE MOUNTING CHANNEL TO DETERMINE WHICH HOLE COMBINATION SHOULD BE USED. BE SURE TO KEEP THE BOLTS AS CLOSE TO THE BEAM AS POSSIBLE.
2. USING THE MOUNTING CHANNEL AS A TEMPLATE, DRILL 9/16" HOLES IN THE UPPER AND LOWER REAR FLANGE OF AD PANEL WHERE THE SUPPORTS WILL GO.
3. REMOVE BACKSHEETS IN AREAS ABOVE AND BELOW HOLES DRILLED IN STEP 2.
4. PLACE SQUARE NUTS INSIDE CHANNEL AND THREAD BOLTS THROUGH.
5. REPLACE BACKSHEETS REMOVED IN STEP 3.
6. LIFT AD PANEL INTO POSITION WITH BOLTS STILL IN PLACE.
7. PLACE MOUNTING ANGLES OVER EACH PAIR OF BOLTS AND SECURE WITH LOCK WASHERS AND HEX NUTS.
8. WHEN PANEL IS ADJUSTED TO FINAL DESIRED POSITION, TIGHTEN HEX NUTS FIRMLY.

DAKTRONICS, INC. BROOKINGS, SD 57006				
PROJ: OUTDOOR SCOREBOARDS				
TITLE: AD PANEL MOUNTING				
DES. BY: .		DRAWN BY: MGUNDERSON		DATE: 09JUL92
REVISION		APPR. BY:	1091-R10A-52187	
		SCALE: NONE		
2	13AUG97	INCLUDED INSTRUCTIONS FOR AD PANELS WITH BACKSHEETS.	JAA	
1	26MAY93	ADDED DESCRIPTION TEXT TO PARTS.	MGG	
REV.	DATE	DESCRIPTION	BY	APPR.

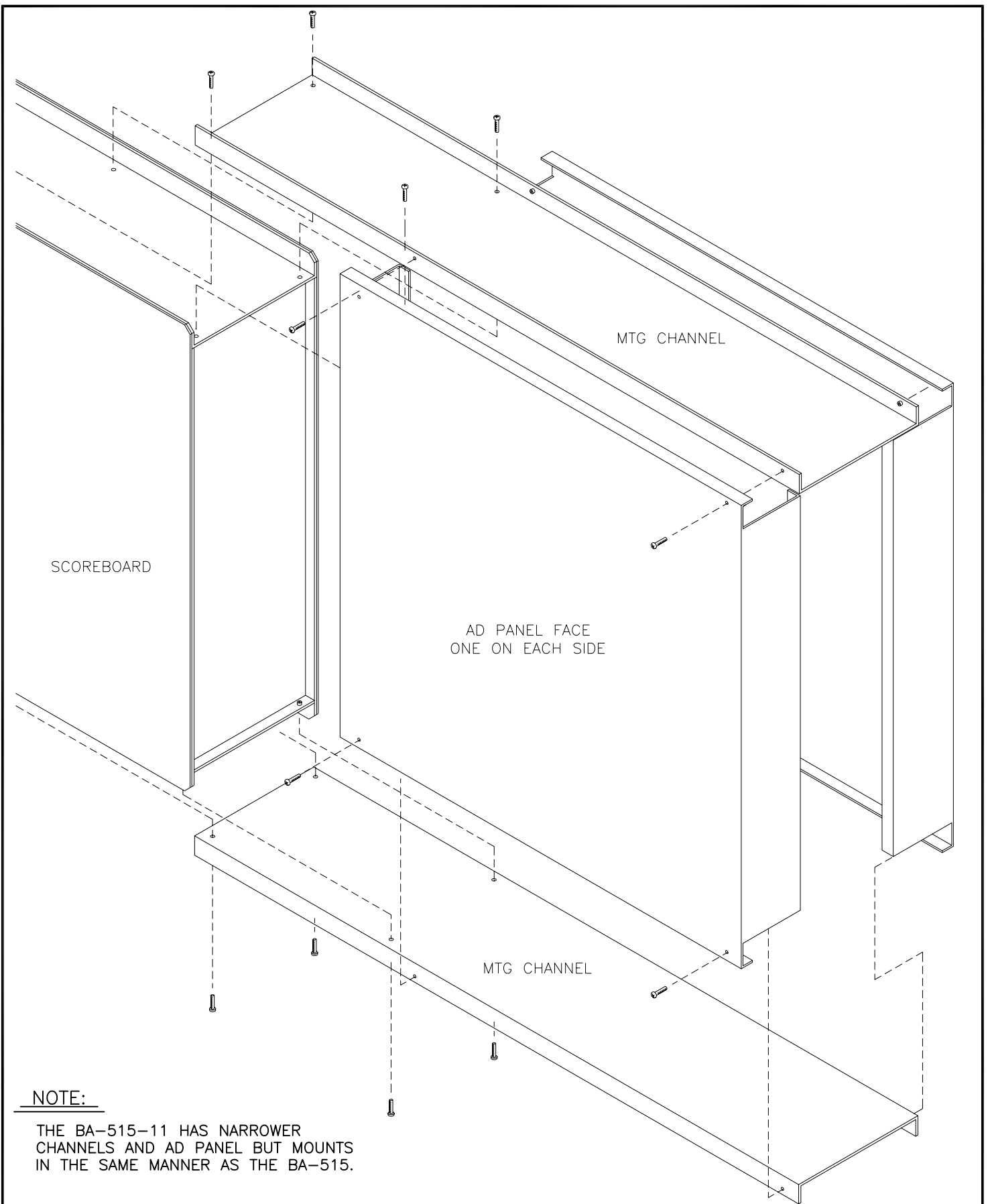

NOTE:

THE BA-515-11 HAS NARROWER CHANNELS AND AD PANEL BUT MOUNTS IN THE SAME MANNER AS THE BA-515.

03	21AUG01	ADDED NOTE FOR BA-515-11	MCOPL	
2	02JUN95	ADDED BACK SIDE AD PANEL FACE.	MGG	
1	29 JUNE 94	MADE FLANGES 0.5 DEEPER.	NJA	
REV.	DATE	DESCRIPTION	BY	APPR.

DAKTRONICS, INC. BROOKINGS, SD 57006			
PROJ: BASEBALL SCOREBOARDS			
TITLE: ASSEMBLY, AD PANEL, BA-515 / BA-515-11			
DES. BY: MGUNDE		DRAWN BY: MGUNDE	
		DATE: 07AUG92	
REVISION	APPR. BY:	1091-R10A-52585	
	SCALE: 1 = 10		

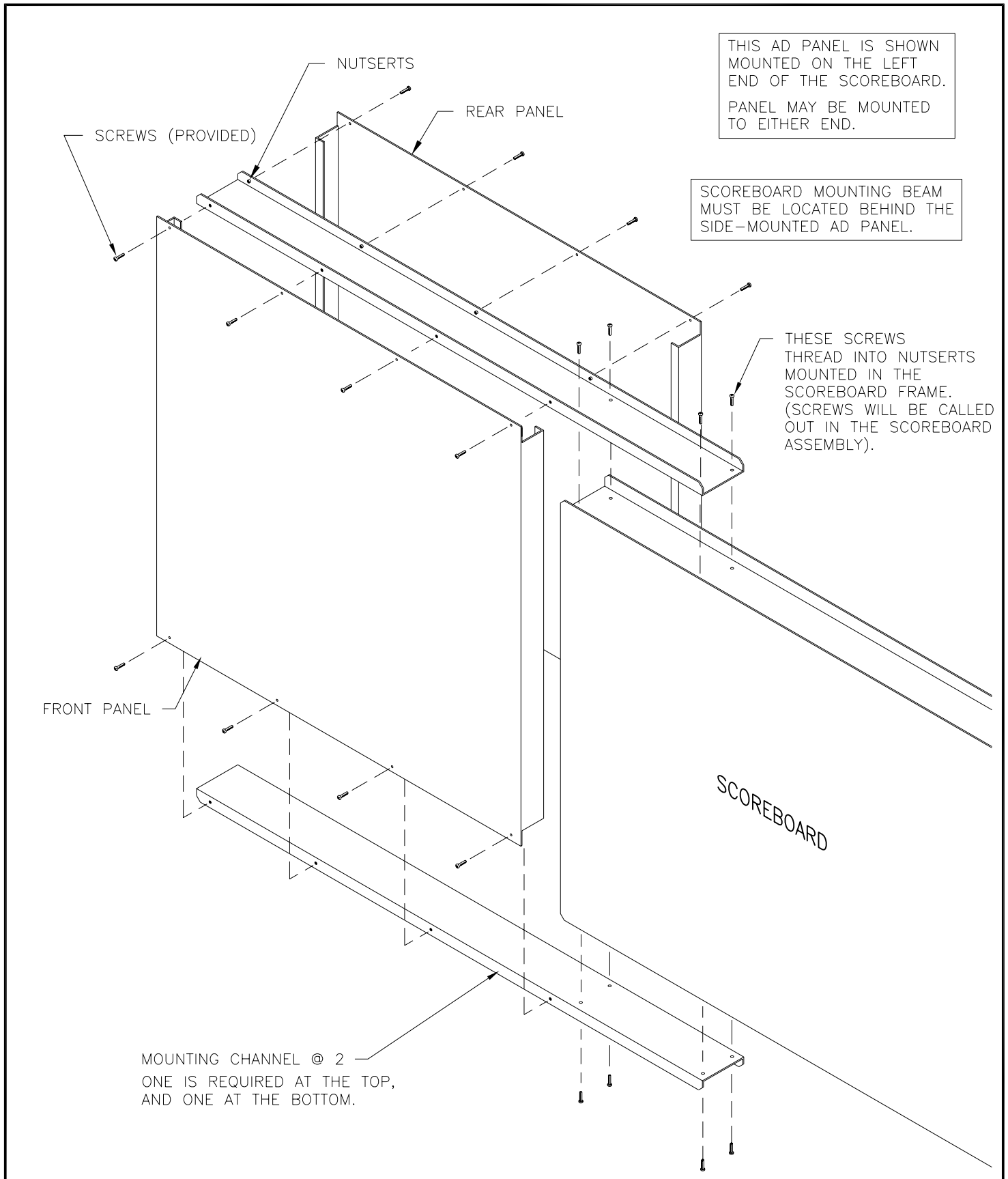

THIS AD PANEL IS SHOWN MOUNTED ON THE LEFT END OF THE SCOREBOARD. PANEL MAY BE MOUNTED TO EITHER END.

SCOREBOARD MOUNTING BEAM MUST BE LOCATED BEHIND THE SIDE-MOUNTED AD PANEL.

THESE SCREWS THREAD INTO NUTSERTS MOUNTED IN THE SCOREBOARD FRAME. (SCREWS WILL BE CALLED OUT IN THE SCOREBOARD ASSEMBLY).

MOUNTING CHANNEL @ 2
ONE IS REQUIRED AT THE TOP, AND ONE AT THE BOTTOM.

THE CONCEPTS EXPRESSED AND DETAILS SHOWN ON THIS DRAWING ARE CONFIDENTIAL AND PROPRIETARY. DO NOT REPRODUCE BY ANY MEANS, INCLUDING ELECTRONICALLY WITHOUT THE EXPRESSED WRITTEN CONSENT OF DAKTRONICS, INC. COPYRIGHT 2004 DAKTRONICS, INC.

DAKTRONICS, INC. BROOKINGS, SD 57006

PROJ:	BASEBALL
TITLE:	AD PANEL MOUNTING, BA-518
DES. BY:	DRAWN BY: C FICKBOHM
	DATE: 25 AUG 92
REVISION	APPR. BY:
03	SCALE: 1=15
1091-E10A-52811	

REV.	DATE	DESCRIPTION	BY	APPR.
03	17MAR04	ADDED MISC. TEXT	MCOPL	
2	08MAY95	ADDED REAR PANEL, INCREASED FLANGE DEPTH.	AVB	AVB
1	6 JAN 93	REMOVE TOP AND BOTTOM FLANGES ON PANEL. CHANGED FROM 6 SCREWS TO 8 TO ATTACH AD PANEL TO MTG CHANNELS.	C FICK	

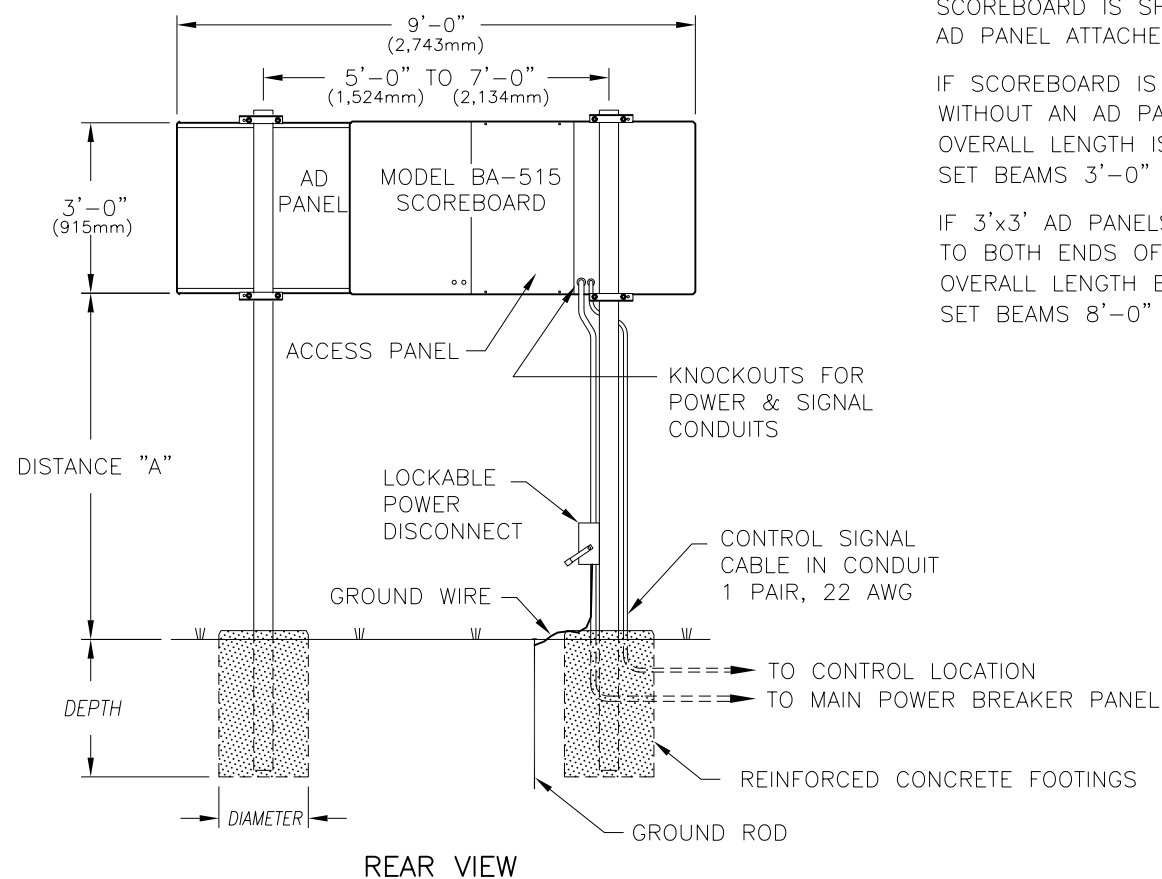

SCOREBOARD IS SHOWN WITH A 3' X 3' AD PANEL ATTACHED TO ONE END.

IF SCOREBOARD IS INSTALLED WITHOUT AN AD PANEL, OVERALL LENGTH IS 6'-0". SET BEAMS 3'-0" TO 5'-0" C-C.

IF 3'x3' AD PANELS ARE ATTACHED TO BOTH ENDS OF THE SCOREBOARD, OVERALL LENGTH BECOMES 12'-0". SET BEAMS 8'-0" TO 10'-0" C-C.

REAR VIEW

MODEL BA-515 WITHOUT AD PANEL					
DISTANCE "A" (SEE FIGURE)	TOTAL DISPLAY SIZE		DESIGN WIND VELOCITY		
			70 MPH	80 MPH	100 MPH
10'-0"	6'-0" x 3'-0"	BEAM FOOTING	W6x9 2.0' x 3.2'	W10x12 2.5' x 3.3'	W4x13 2.5' x 3.9'
12'-0"	6'-0" x 3'-0"	BEAM FOOTING	W6x12 2.5' x 3.2'	W10x15 2.5' x 3.5'	W6x15 2.5' x 4.1'
14'-0"	6'-0" x 3'-0"	BEAM FOOTING	W4x13 2.5' x 3.4'	W6x15 2.5' x 3.8'	W5x16 2.5' x 4.4'

MODEL BA-515 WITH 3'x3' AD PANEL ON ONE END					
DISTANCE "A" (SEE FIGURE)	TOTAL DISPLAY SIZE		DESIGN WIND VELOCITY		
			70 MPH	80 MPH	100 MPH
10'-0"	9'-0" x 3'-0"	BEAM FOOTING	W10x12 2.5' x 3.3'	W10x12 2.5' x 3.7'	W10x15 2.5' x 4.3'
12'-0"	9'-0" x 3'-0"	BEAM FOOTING	W6x12 2.5' x 3.5'	W10x15 2.5' x 3.9'	W10x15 2.5' x 4.6'
14'-0"	9'-0" x 3'-0"	BEAM FOOTING	W6x15 2.5' x 3.8'	W6x15 2.5' x 4.2'	W8x18 2.5' x 4.9'

FOOTING = DIAMETER X DEPTH

FOOTING DIMENSIONS ARE SUGGESTIONS ONLY, PROVIDED TO ASSIST WITH ESTIMATING INSTALLATION COSTS AND ARE NOT INTENDED FOR CONSTRUCTION PURPOSES.

FOOTING DIMENSIONS ARE BASED ON ASSUMED SOIL BEARING PRESSURE OF 2000 LB/FT²

ACTUAL FOOTING DEPTH AND DIAMETER FOR A PARTICULAR INSTALLATION MUST BE DETERMINED BY A QUALIFIED STRUCTURAL ENGINEER, USING DATA FROM A SOIL SAMPLE TEST AT THE SITE.

DAKTRONICS, INC. IS NOT RESPONSIBLE FOR STRUCTURES DESIGNED AND INSTALLED BY OTHERS.

MODEL BA-515 WITH 3'x3' AD PANELS ON BOTH ENDS					
DISTANCE "A" (SEE FIGURE)	TOTAL DISPLAY SIZE		DESIGN WIND VELOCITY		
			70 MPH	80 MPH	100 MPH
10'-0"	12'-0" x 3'-0"	BEAM FOOTING	W6x12 2.5' x 3.6'	W4x13 2.5' x 4.0'	W6x15 2.5' x 4.7'
12'-0"	12'-0" x 3'-0"	BEAM FOOTING	W4x13 2.5' x 3.8'	W6x15 2.5' x 4.2'	W5x19 2.5' x 4.9'
14'-0"	12'-0" x 3'-0"	BEAM FOOTING	W6x15 2.5' x 4.1'	W8x18 2.5' x 4.5'	W8x24 2.5' x 5.3'

THE CONCEPTS EXPRESSED AND DETAILS SHOWN ON THIS DRAWING ARE CONFIDENTIAL AND PROPRIETARY. DO NOT REPRODUCE BY ANY MEANS, INCLUDING ELECTRONICALLY WITHOUT THE EXPRESSED WRITTEN CONSENT OF DAKTRONICS, INC. COPYRIGHT 2004 DAKTRONICS, INC.

REV.	DATE	DESCRIPTION	BY	APPR.
03	24 OCT 07	ADDED MILLIMETERS DIMENSIONS	KDD	
02	02JUL04	CHANGED SEVERAL BEAM SIZES	MCOP	
1	14DEC00	REVISED COLUMN SECTIONS & FOOTINGS.	MVD	

DAKTRONICS, INC. BROOKINGS, SD 57006			
PROJ: OUTDOOR SCOREBOARDS			
TITLE: INSTALLATION SPECIFICATIONS, BA-515			
DES. BY: AVB		DRAWN BY: A VANBEMMEL DATE: 05FEB93	
REVISION	APPR. BY:	1091-R10A-55003	
03	SCALE: 1=40		

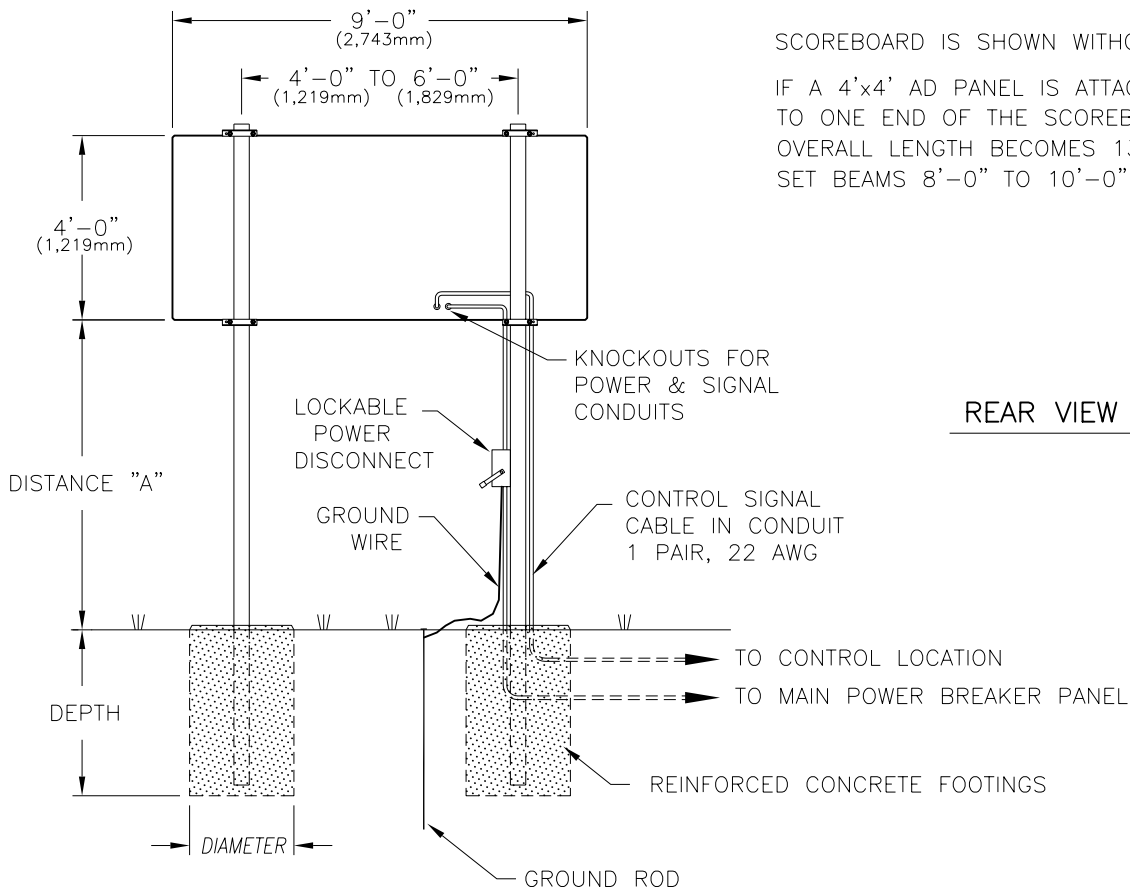

SCOREBOARD IS SHOWN WITHOUT AD PANEL.

IF A 4'x4' AD PANEL IS ATTACHED TO ONE END OF THE SCOREBOARD, OVERALL LENGTH BECOMES 13'-0". SET BEAMS 8'-0" TO 10'-0" C-C.

REAR VIEW

MODEL BA-518 WITHOUT AD PANEL					
DISTANCE "A" (SEE FIGURE)	TOTAL DISPLAY SIZE		DESIGN WIND VELOCITY		
			70 MPH	80 MPH	100 MPH
10'-0"	9'-0" x 4'-0"	BEAM FOOTING	W6x12 3.0' x 3.4'	W4x13 3.0' x 3.8'	W5x16 3.0' x 4.4'
12'-0"	9'-0" x 4'-0"	BEAM FOOTING	W4x13 3.0' x 3.6'	W6x15 3.0' x 4.0'	W5x19 3.0' x 4.7'
14'-0"	9'-0" x 4'-0"	BEAM FOOTING	W6x15 3.0' x 3.9'	W5x19 3.0' x 4.3'	W8x24 3.0' x 5.0'

MODEL BA-518 WITH 30"-HIGH HORIZONTAL AD PANEL					
DISTANCE "A" (SEE FIGURE)	TOTAL DISPLAY SIZE		DESIGN WIND VELOCITY		
			70 MPH	80 MPH	100 MPH
10'-0"	9'-0" x 6'-6"	BEAM FOOTING	W5x16 3.0' x 4.1'	W5x19 3.0' x 4.5'	W8x24 3.0' x 5.3'
12'-0"	9'-0" x 6'-6"	BEAM FOOTING	W5x19 3.0' x 4.3'	W8x24 3.0' x 4.8'	W8x28 3.0' x 5.6'
14'-0"	9'-0" x 6'-6"	BEAM FOOTING	W8x24 3.0' x 4.5'	W8x24 3.0' x 5.0'	W8x31 3.0' x 5.9'

FOOTING = DIAMETER X DEPTH

FOOTING DIMENSIONS ARE SUGGESTIONS ONLY, PROVIDED TO ASSIST WITH ESTIMATING INSTALLATION COSTS AND ARE NOT INTENDED FOR CONSTRUCTION PURPOSES.

FOOTING DIMENSIONS ARE BASED ON ASSUMED SOIL BEARING PRESSURE OF 2000 LB/FT²

ACTUAL FOOTING DEPTH AND DIAMETER FOR A PARTICULAR INSTALLATION MUST BE DETERMINED BY A QUALIFIED STRUCTURAL ENGINEER, USING DATA FROM A SOIL SAMPLE TEST AT THE SITE.

DAKTRONICS, INC. IS NOT RESPONSIBLE FOR STRUCTURES DESIGNED AND INSTALLED BY OTHERS.

MODEL BA-518 WITH 4' SQUARE AD PANEL AT ONE END					
DISTANCE "A" (SEE FIGURE)	TOTAL DISPLAY SIZE		DESIGN WIND VELOCITY		
			70 MPH	80 MPH	100 MPH
10'-0"	13'-0" x 4'-0"	BEAM FOOTING	W4x13 3.0' x 3.8'	W6x15 3.0' x 4.2'	W5x19 3.0' x 5.0'
12'-0"	13'-0" x 4'-0"	BEAM FOOTING	W6x15 3.0' x 4.0'	W5x19 3.0' x 4.4'	W8x24 3.0' x 5.2'
14'-0"	13'-0" x 4'-0"	BEAM FOOTING	W5x19 3.0' x 4.3'	W6x20 3.0' x 4.7'	W8x28 3.0' x 5.6'

REV.	DATE	DESCRIPTION	BY	APPR.
03	24 OCT 07	ADDED MILLIMETERS DIMENSIONS	KDD	
2	19DEC00	REVISED COLUMN SECTIONS & FOOTINGS.	MVD	
1	06MAY94	CHANGED HEIGHT OF DISPLAY WITH 30" AD PANEL TO 6'-6".	AVB	AVB

DAKTRONICS, INC. BROOKINGS, SD 57006			
PROJ: OUTDOOR SCOREBOARDS			
TITLE: INSTALLATION SPECIFICATIONS, BA-518			
DES. BY: AVB		DRAWN BY: A VANBEMMEL DATE: 05FEB93	
REVISION	APPR. BY:	1091-R10A-55004	
03	SCALE: 1=50		

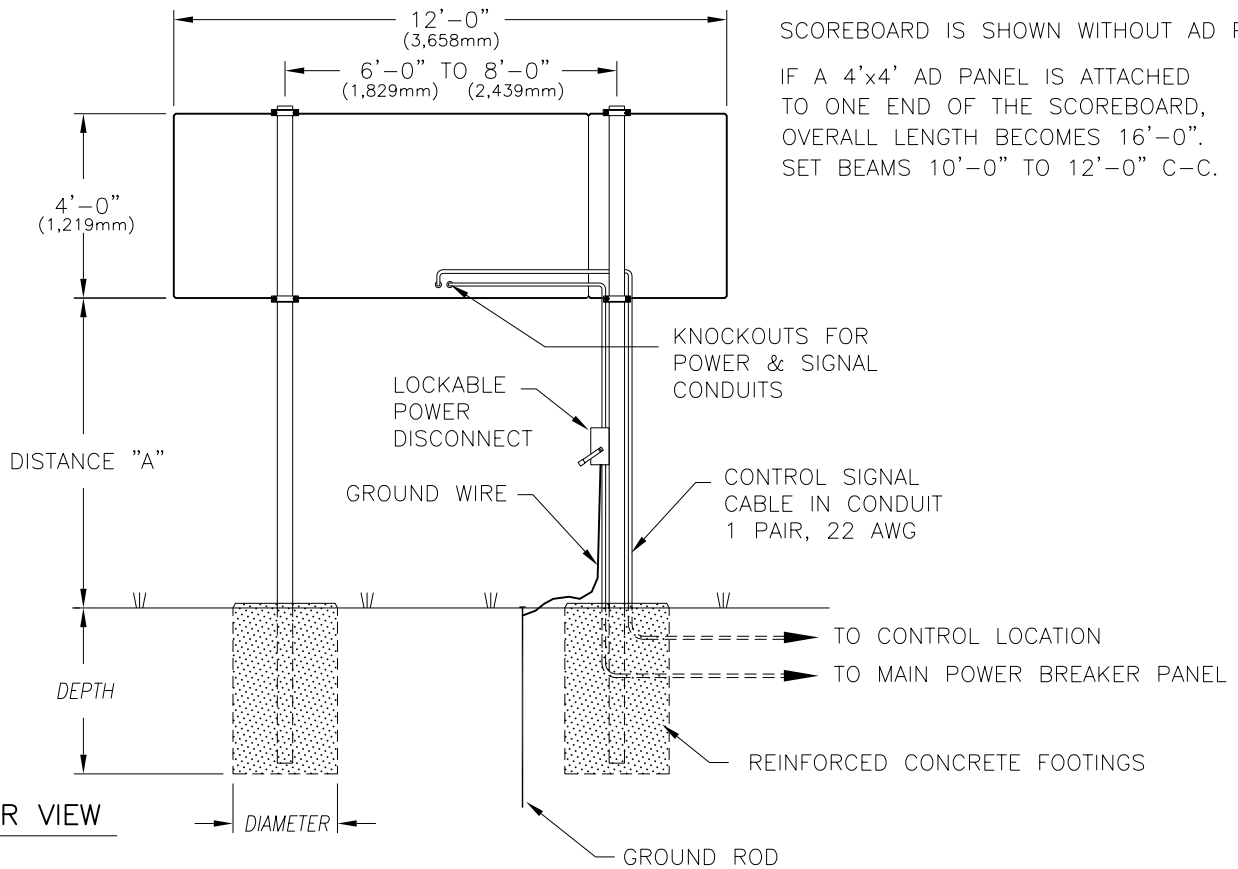

SCOREBOARD IS SHOWN WITHOUT AD PANEL.
 IF A 4'x4' AD PANEL IS ATTACHED TO ONE END OF THE SCOREBOARD, OVERALL LENGTH BECOMES 16'-0". SET BEAMS 10'-0" TO 12'-0" C-C.

MODEL BA-718 WITHOUT AD PANEL					
DISTANCE "A" (SEE FIGURE)	TOTAL DISPLAY SIZE		DESIGN WIND VELOCITY		
			70 MPH	80 MPH	100 MPH
10'-0"	12'-0" x 4'-0"	BEAM FOOTING	W4x13 3.0' x 3.7'	W6x15 3.0' x 4.1'	W5x19 3.0' x 4.8'
12'-0"	12'-0" x 4'-0"	BEAM FOOTING	W6x15 3.0' x 3.9'	W8x18 3.0' x 4.3'	W8x24 3.0' x 5.1'
14'-0"	12'-0" x 4'-0"	BEAM FOOTING	W5x19 3.0' x 4.2'	W6x20 3.0' x 4.6'	W8x24 3.0' x 5.4'

MODEL BA-718 WITH 30"-HIGH HORIZONTAL AD PANEL					
DISTANCE "A" (SEE FIGURE)	TOTAL DISPLAY SIZE		DESIGN WIND VELOCITY		
			70 MPH	80 MPH	100 MPH
10'-0"	12'-0" x 6'-6"	BEAM FOOTING	W5x19 3.0' x 4.5'	W6x20 3.0' x 5.0'	W8x28 3.0' x 5.8'
12'-0"	12'-0" x 6'-6"	BEAM FOOTING	W8x24 3.0' x 4.7'	W8x24 3.0' x 5.2'	W8x31 3.0' x 6.1'
14'-0"	12'-0" x 6'-6"	BEAM FOOTING	W8x24 3.0' x 5.0'	W8x28 3.0' x 5.5'	W10x33 3.0' x 6.4'

FOOTING = DIAMETER X DEPTH

FOOTING DIMENSIONS ARE SUGGESTIONS ONLY, PROVIDED TO ASSIST WITH ESTIMATING INSTALLATION COSTS AND ARE NOT INTENDED FOR CONSTRUCTION PURPOSES.

FOOTING DIMENSIONS ARE BASED ON ASSUMED SOIL BEARING PRESSURE OF 2000 LB/FT²

ACTUAL FOOTING DEPTH AND DIAMETER FOR A PARTICULAR INSTALLATION MUST BE DETERMINED BY A QUALIFIED STRUCTURAL ENGINEER, USING DATA FROM A SOIL SAMPLE TEST AT THE SITE.

DAKTRONICS, INC. IS NOT RESPONSIBLE FOR STRUCTURES DESIGNED AND INSTALLED BY OTHERS.

MODEL BA-718 WITH 4' SQUARE AD PANEL AT ONE END					
DISTANCE "A" (SEE FIGURE)	TOTAL DISPLAY SIZE		DESIGN WIND VELOCITY		
			70 MPH	80 MPH	100 MPH
10'-0"	16'-0" x 4'-0"	BEAM FOOTING	W6x15 3.0' x 4.1'	W5x16 3.0' x 4.5'	W6x20 3.0' x 5.3'
12'-0"	16'-0" x 4'-0"	BEAM FOOTING	W8x18 3.0' x 4.3'	W5x19 3.0' x 4.7'	W8x24 3.0' x 5.6'
14'-0"	16'-0" x 4'-0"	BEAM FOOTING	W6x20 3.0' x 4.6'	W8x24 3.0' x 5.0'	W8x28 3.0' x 5.9'

REV.	DATE	DESCRIPTION	BY	APPR.
03	24 OCT 07	ADDED MILLIMETERS DIMENSIONS	KDD	
2	19DEC00	REVISED COLUMN SECTIONS & FOOTINGS.	MVD	
1	06MAY94	CHANGED HEIGHT OF DISPLAY WITH 30" AD PANEL TO 6'-6".	AVB	

DAKTRONICS, INC. BROOKINGS, SD 57006			
PROJ: OUTDOOR SCOREBOARDS			
TITLE: INSTALLATION SPECIFICATIONS, BA-718			
DES. BY: AVB		DRAWN BY: A VANBEMMEL DATE: 04JAN93	
REVISION	APPR. BY:	1091-R10A-55005	
03	SCALE: 1=50		

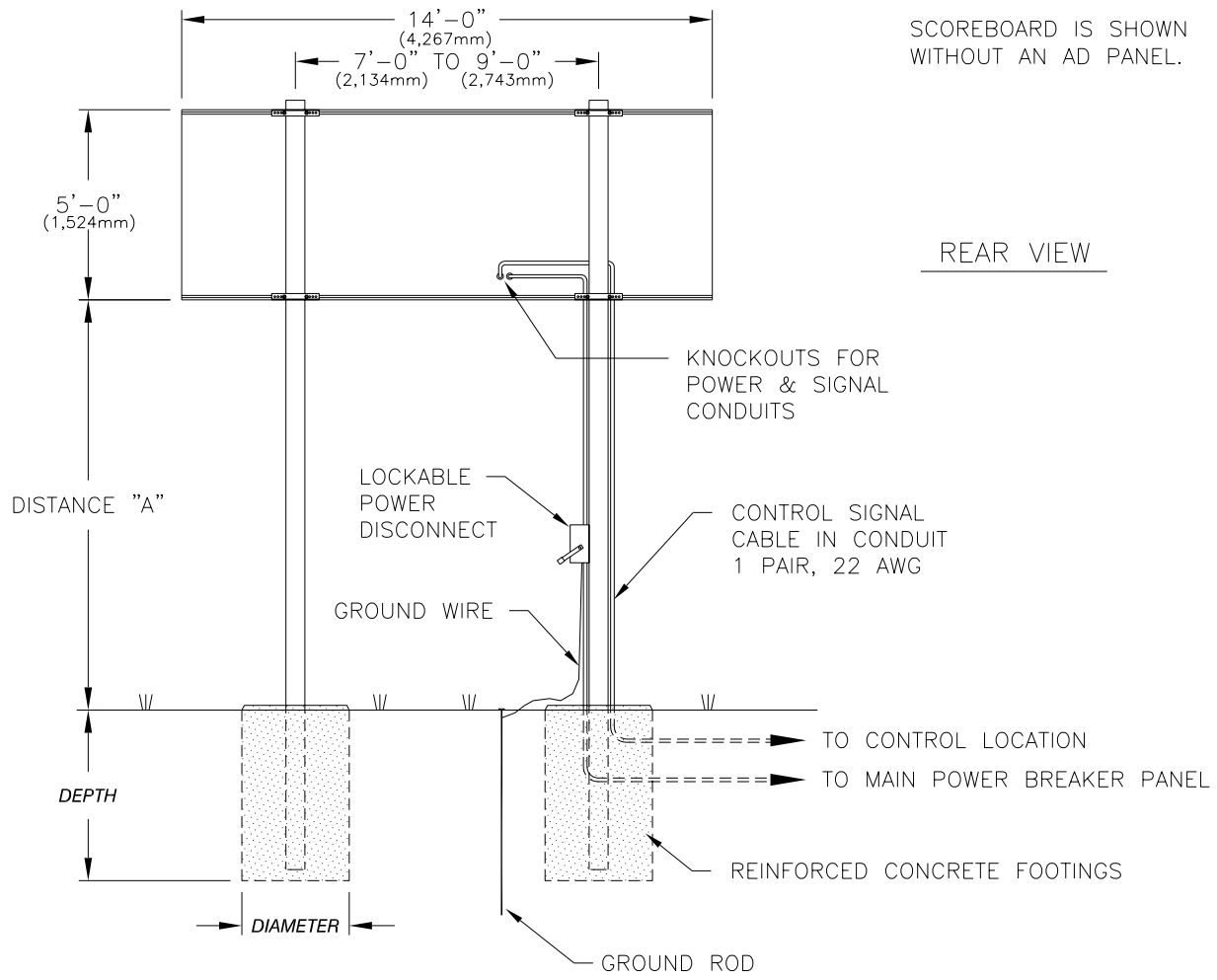

MODEL BA-618 WITHOUT AD PANEL					
DISTANCE "A" (SEE FIGURE)	TOTAL DISPLAY SIZE		DESIGN WIND VELOCITY		
			70 MPH	80 MPH	100 MPH
10'-0"	14'-0" x 5'-0"	BEAM FOOTING	W5x16 3.0' x 4.3'	W5x19 3.0' x 4.7'	W8x24 3.0' x 5.5'
12'-0"	14'-0" x 5'-0"	BEAM FOOTING	W5x19 3.0' x 4.5'	W8x24 3.0' x 5.0'	W8x28 3.0' x 5.8'
14'-0"	14'-0" x 5'-0"	BEAM FOOTING	W8x24 3.0' x 4.7'	W8x24 3.0' x 5.2'	W8x31 3.0' x 6.1'

MODEL BA-618 WITH 30"-HIGH AD PANEL					
DISTANCE "A" (SEE FIGURE)	TOTAL DISPLAY SIZE		DESIGN WIND VELOCITY		
			70 MPH	80 MPH	100 MPH
10'-0"	14'-0" x 7'-6"	BEAM FOOTING	W8x24 3.0' x 5.0'	W6x25 3.0' x 5.5'	W8x31 3.0' x 6.5'
12'-0"	14'-0" x 7'-6"	BEAM FOOTING	W8x28 3.0' x 5.3'	W8x31 3.0' x 5.8'	W8x35 3.0' x 6.8'
14'-0"	14'-0" x 7'-6"	BEAM FOOTING	W8x31 3.0' x 5.5'	W8x31 3.0' x 6.1'	W8x40 3.0' x 7.1'

FOOTING = DIAMETER X DEPTH

FOOTING DIMENSIONS ARE SUGGESTIONS ONLY, PROVIDED TO ASSIST WITH ESTIMATING INSTALLATION COSTS AND ARE NOT INTENDED FOR CONSTRUCTION PURPOSES.

FOOTING DIMENSIONS ARE BASED ON ASSUMED SOIL BEARING PRESSURE OF 2000 LB/FT²

ACTUAL FOOTING DEPTH AND DIAMETER FOR A PARTICULAR INSTALLATION MUST BE DETERMINED BY A QUALIFIED STRUCTURAL ENGINEER, USING DATA FROM A SOIL SAMPLE TEST AT THE SITE.

DAKTRONICS, INC. IS NOT RESPONSIBLE FOR STRUCTURES DESIGNED AND INSTALLED BY OTHERS.

REV.	DATE	DESCRIPTION	BY	APPR.
03	24 OCT 07	ADDED MILLIMETERS DIMENSIONS	KDD	
2	19DEC00	REVISED COLUMN SECTIONS & FOOTINGS.	MVD	
1	25NOV97	REPLACED BA-618L WITH BA-618.	TWEBER	

DAKTRONICS, INC. BROOKINGS, SD 57006			
PROJ: OUTDOOR SCOREBOARDS			
TITLE: INSTALLATION SPECIFICATIONS, BA-618			
DES. BY: AVB		DRAWN BY: A VANBEMMEL DATE: 12FEB93	
REVISION	APPR. BY:	1091-R10A-55006	
03	SCALE: 1=60		

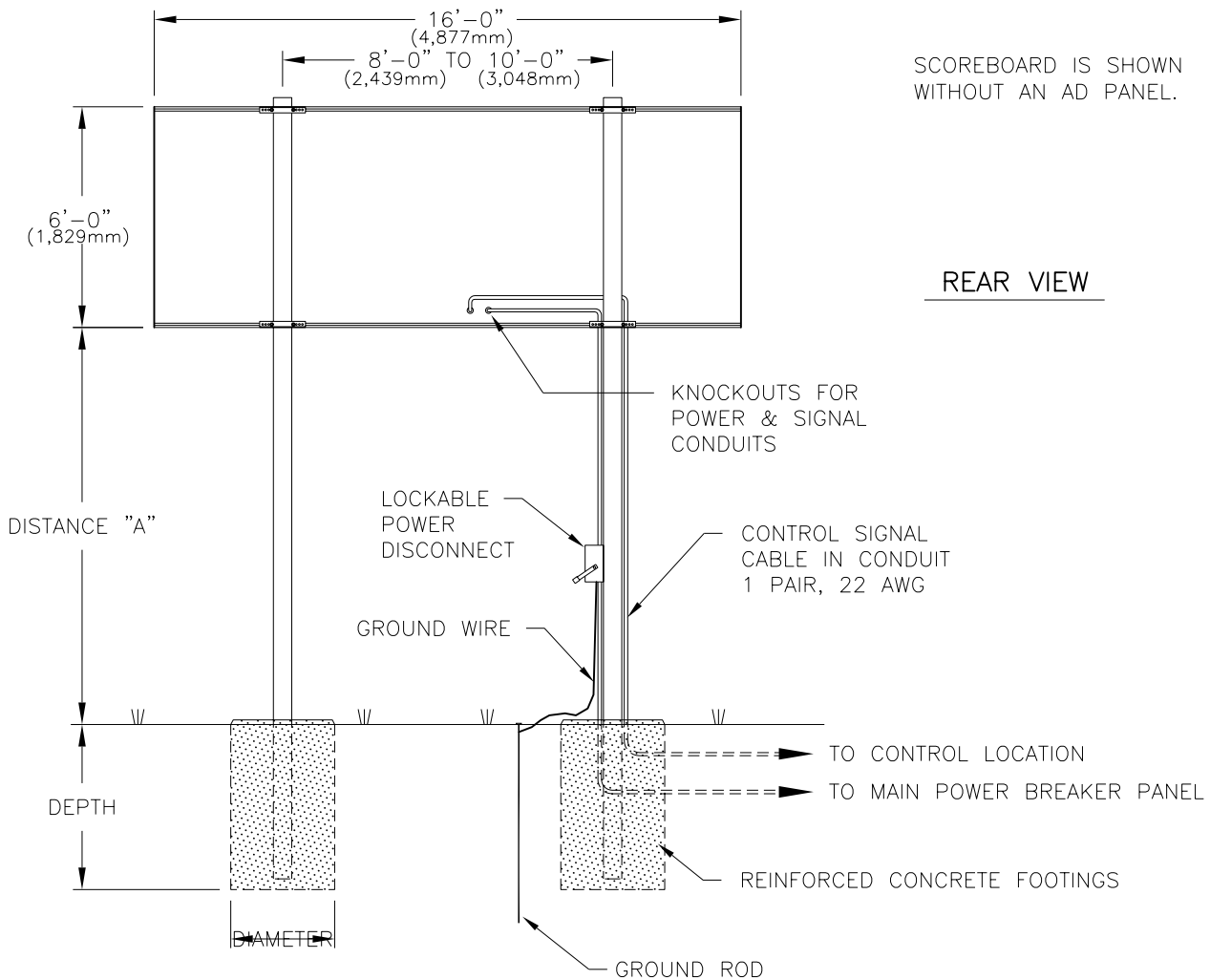

MODEL BA-624 & SO-2013 WITHOUT AD PANEL					
DISTANCE "A" (SEE FIGURE)	TOTAL DISPLAY SIZE		DESIGN WIND VELOCITY		
			70 MPH	80 MPH	100 MPH
10'-0"	16'-0" x 6'-0"	BEAM FOOTING	W5x19 3.0' x 4.8'	W8x24 3.0' x 5.3'	W8x28 3.0' x 6.2'
12'-0"	16'-0" x 6'-0"	BEAM FOOTING	W8x24 3.0' x 5.0'	W8x28 3.0' x 5.6'	W8x31 3.0' x 6.5'
14'-0"	16'-0" x 6'-0"	BEAM FOOTING	W8x28 3.0' x 5.3'	W8x31 3.0' x 5.8'	W8x35 3.0' x 6.8'

MODEL BA-624 & SO-2013 WITH 30"-HIGH AD PANEL					
DISTANCE "A" (SEE FIGURE)	TOTAL DISPLAY SIZE		DESIGN WIND VELOCITY		
			70 MPH	80 MPH	100 MPH
10'-0"	16'-0" x 8'-6"	BEAM FOOTING	W8x28 3.0' x 5.5'	W8x31 3.0' x 6.1'	W8x35 3.0' x 7.2'
12'-0"	16'-0" x 8'-6"	BEAM FOOTING	W8x31 3.0' x 5.8'	W10x33 3.0' x 6.4'	W8x40 3.0' x 7.5'
14'-0"	16'-0" x 8'-6"	BEAM FOOTING	W10x33 3.0' x 6.1'	W10x39 3.0' x 6.7'	W8x48 3.0' x 7.9'

FOOTING = DIAMETER X DEPTH

FOOTING DIMENSIONS ARE SUGGESTIONS ONLY, PROVIDED TO ASSIST WITH ESTIMATING INSTALLATION COSTS AND ARE NOT INTENDED FOR CONSTRUCTION PURPOSES.

FOOTING DIMENSIONS ARE BASED ON ASSUMED SOIL BEARING PRESSURE OF 2000 LB/FT²

ACTUAL FOOTING DEPTH AND DIAMETER FOR A PARTICULAR INSTALLATION MUST BE DETERMINED BY A QUALIFIED STRUCTURAL ENGINEER, USING DATA FROM A SOIL SAMPLE TEST AT THE SITE.

DAKTRONICS, INC. IS NOT RESPONSIBLE FOR STRUCTURES DESIGNED AND INSTALLED BY OTHERS.

REV.	DATE	DESCRIPTION	BY	APPR.
04	24 OCT 07	ADDED MILLIMETERS DIMENSIONS	KDD	
03	21 SEPT 04	ADDED MODEL SO-2013	CAC	
2	19DEC00	REVISED COLUMN SECTIONS & FOOTINGS.	MVD	
1	25NOV97	REPLACED BA-624L WITH BA-624.	TWEBER	

DAKTRONICS, INC. BROOKINGS, SD 57006			
PROJ: OUTDOOR SCOREBOARDS			
TITLE: INSTALLATION SPECIFICATIONS, BA-624 & SO-2013			
DES. BY: AVB		DRAWN BY: A VANBEMMEL DATE: 15FEB93	
REVISION	APPR. BY:	1091-R10A-55007	
04	SCALE: 1=60		

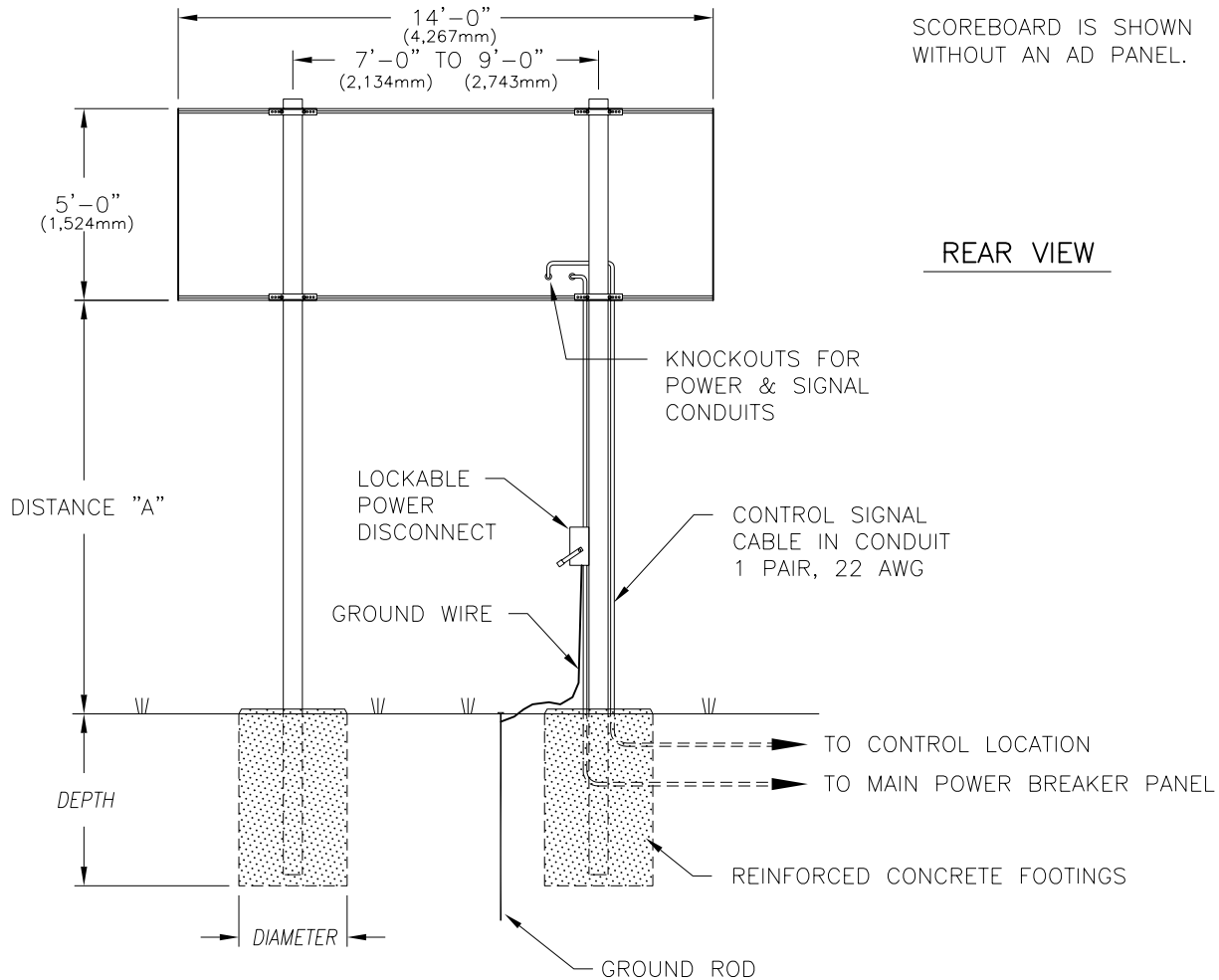

MODEL MS-918 WITHOUT AD PANEL					
DISTANCE "A" (SEE FIGURE)	TOTAL DISPLAY SIZE		DESIGN WIND VELOCITY		
			70 MPH	80 MPH	100 MPH
10'-0"	14'-0" x 5'-0"	BEAM FOOTING	W5x16 3.0' x 4.3'	W5x19 3.0' x 4.7'	W8x24 3.0' x 5.5'
12'-0"	14'-0" x 5'-0"	BEAM FOOTING	W5x19 3.0' x 4.5'	W8x24 3.0' x 5.0'	W8x28 3.0' x 5.8'
14'-0"	14'-0" x 5'-0"	BEAM FOOTING	W8x24 3.0' x 4.7'	W8x24 3.0' x 5.2'	W8x31 3.0' x 6.1'

MODEL MS-918 WITH 30"-HIGH AD PANEL					
DISTANCE "A" (SEE FIGURE)	TOTAL DISPLAY SIZE		DESIGN WIND VELOCITY		
			70 MPH	80 MPH	100 MPH
10'-0"	14'-0" x 7'-6"	BEAM FOOTING	W8x24 3.0' x 5.0'	W6x25 3.0' x 5.5'	W8x31 3.0' x 6.5'
12'-0"	14'-0" x 7'-6"	BEAM FOOTING	W8x28 3.0' x 5.3'	W8x31 3.0' x 5.8'	W8x35 3.0' x 6.8'
14'-0"	14'-0" x 7'-6"	BEAM FOOTING	W8x31 3.0' x 5.5'	W8x31 3.0' x 6.1'	W8x40 3.0' x 7.1'

FOOTING = DIAMETER X DEPTH

FOOTING DIMENSIONS ARE SUGGESTIONS ONLY, PROVIDED TO ASSIST WITH ESTIMATING INSTALLATION COSTS AND ARE NOT INTENDED FOR CONSTRUCTION PURPOSES.

FOOTING DIMENSIONS ARE BASED ON ASSUMED SOIL BEARING PRESSURE OF 2000 LB/FT²

ACTUAL FOOTING DEPTH AND DIAMETER FOR A PARTICULAR INSTALLATION MUST BE DETERMINED BY A QUALIFIED STRUCTURAL ENGINEER, USING DATA FROM A SOIL SAMPLE TEST AT THE SITE.

DAKTRONICS, INC. IS NOT RESPONSIBLE FOR STRUCTURES DESIGNED AND INSTALLED BY OTHERS.

THE CONCEPTS EXPRESSED AND DETAILS SHOWN ON THIS DRAWING ARE CONFIDENTIAL AND PROPRIETARY. DO NOT REPRODUCE BY ANY MEANS, INCLUDING ELECTRONICALLY WITHOUT THE EXPRESSED WRITTEN CONSENT OF DAKTRONICS, INC. COPYRIGHT 2007 DAKTRONICS, INC.

DAKTRONICS, INC. BROOKINGS, SD 57006

PROJ: **OUTDOOR SCOREBOARDS**

TITLE: **INSTALLATION SPECIFICATIONS, MS-918**

DES. BY: **AVB** DRAWN BY: **A VANBEMMEL** DATE: **15FEB93**

REVISION 02 APPR. BY: SCALE: **1=60**

1091-R10A-55009

REV.	DATE	DESCRIPTION	BY	APPR.
02	24 OCT 07	ADDED MILLIMETER DIMENSIONS	KDD	
1	20DEC00	REVISED COLUMN SECTIONS & FOOTINGS.	MVD	

SCOREBOARD IS SHOWN WITHOUT AN AD PANEL.

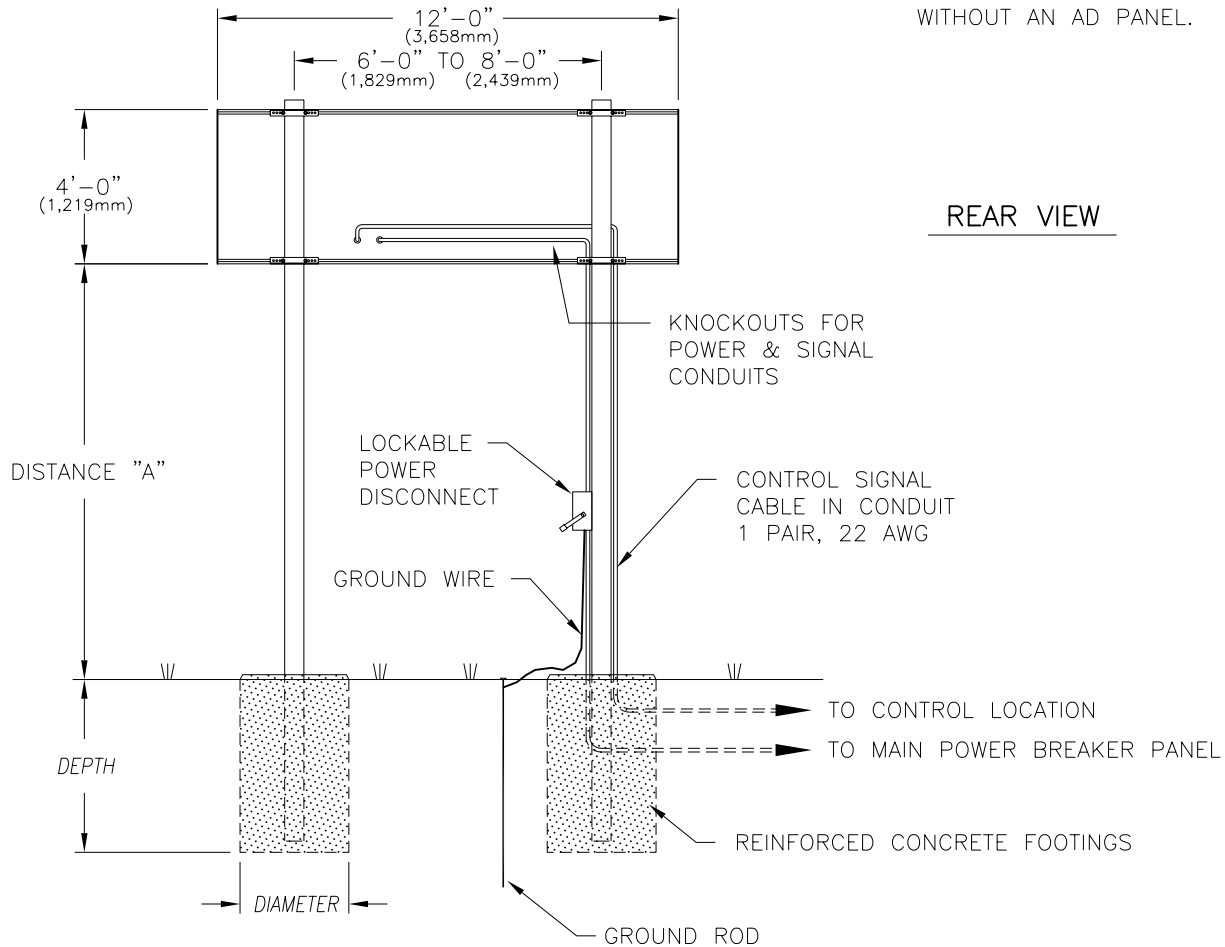

MODEL SO-918 WITHOUT AD PANEL					
DISTANCE "A" (SEE FIGURE)	TOTAL DISPLAY SIZE		DESIGN WIND VELOCITY		
			70 MPH	80 MPH	100 MPH
10'-0"	12'-0" x 4'-0"	BEAM FOOTING	W4x13 3.0' x 3.7'	W6x15 3.0' x 4.1'	W5x19 3.0' x 4.8'
12'-0"	12'-0" x 4'-0"	BEAM FOOTING	W6x15 3.0' x 3.9'	W8x18 3.0' x 4.3'	W8x24 3.0' x 5.1'
14'-0"	12'-0" x 4'-0"	BEAM FOOTING	W5x19 3.0' x 4.2'	W6x20 3.0' x 4.6'	W8x24 3.0' x 5.4'

MODEL SO-918 WITH 30"-HIGH AD PANEL					
DISTANCE "A" (SEE FIGURE)	TOTAL DISPLAY SIZE		DESIGN WIND VELOCITY		
			70 MPH	80 MPH	100 MPH
10'-0"	12'-0" x 6'-6"	BEAM FOOTING	W8x18 3.0' x 5.1'	W6x20 3.0' x 5.6'	W8x24 3.0' x 6.6'
12'-0"	12'-0" x 6'-6"	BEAM FOOTING	W6x20 3.0' x 5.4'	W6x20 3.0' x 5.9'	W12x26 3.0' x 6.9'
14'-0"	12'-0" x 6'-6"	BEAM FOOTING	W12x26 3.0' x 5.6'	W12x26 3.0' x 6.2'	W14x30 3.0' x 7.2'

FOOTING = DIAMETER X DEPTH

FOOTING DIMENSIONS ARE SUGGESTIONS ONLY, PROVIDED TO ASSIST WITH ESTIMATING INSTALLATION COSTS AND ARE NOT INTENDED FOR CONSTRUCTION PURPOSES.

FOOTING DIMENSIONS ARE BASED ON ASSUMED SOIL BEARING PRESSURE OF 2000 LB/FT²

ACTUAL FOOTING DEPTH AND DIAMETER FOR A PARTICULAR INSTALLATION MUST BE DETERMINED BY A QUALIFIED STRUCTURAL ENGINEER, USING DATA FROM A SOIL SAMPLE TEST AT THE SITE.

DAKTRONICS, INC. IS NOT RESPONSIBLE FOR STRUCTURES DESIGNED AND INSTALLED BY OTHERS.

REV.	DATE	DESCRIPTION	BY	APPR.
04	25 OCT 07	ADDED MILLIMETERS DIMENSIONS	KDD	
3	23 FEB 04	ADDED 6'-6" SIZE HEIGHT & NEW COLUMN AND FOOTING SIZES	JLB	
2	30 MAY 02	ADDED MODELS SO-2009 & SO-2010 TO TITLE.	TWEBER	
1	20DEC00	REVISED COLUMN SECTIONS & FOOTINGS.	MVD	

THE CONCEPTS EXPRESSED AND DETAILS SHOWN ON THIS DRAWING ARE CONFIDENTIAL AND PROPRIETARY. DO NOT REPRODUCE BY ANY MEANS, INCLUDING ELECTRONICALLY WITHOUT THE EXPRESSED WRITTEN CONSENT OF DAKTRONICS, INC. COPYRIGHT 2004 DAKTRONICS, INC.

DAKTRONICS, INC. BROOKINGS, SD 57006

PROJ: OUTDOOR SCOREBOARDS
 TITLE: INSTALLATION SPECS, SO-918, SO-2009 and SO-2010
 DES. BY: AVB DRAWN BY: A VANBEMMEL DATE: 15FEB93

REVISION	APPR. BY:	1091-R10A-55010
04	SCALE: 1=60	

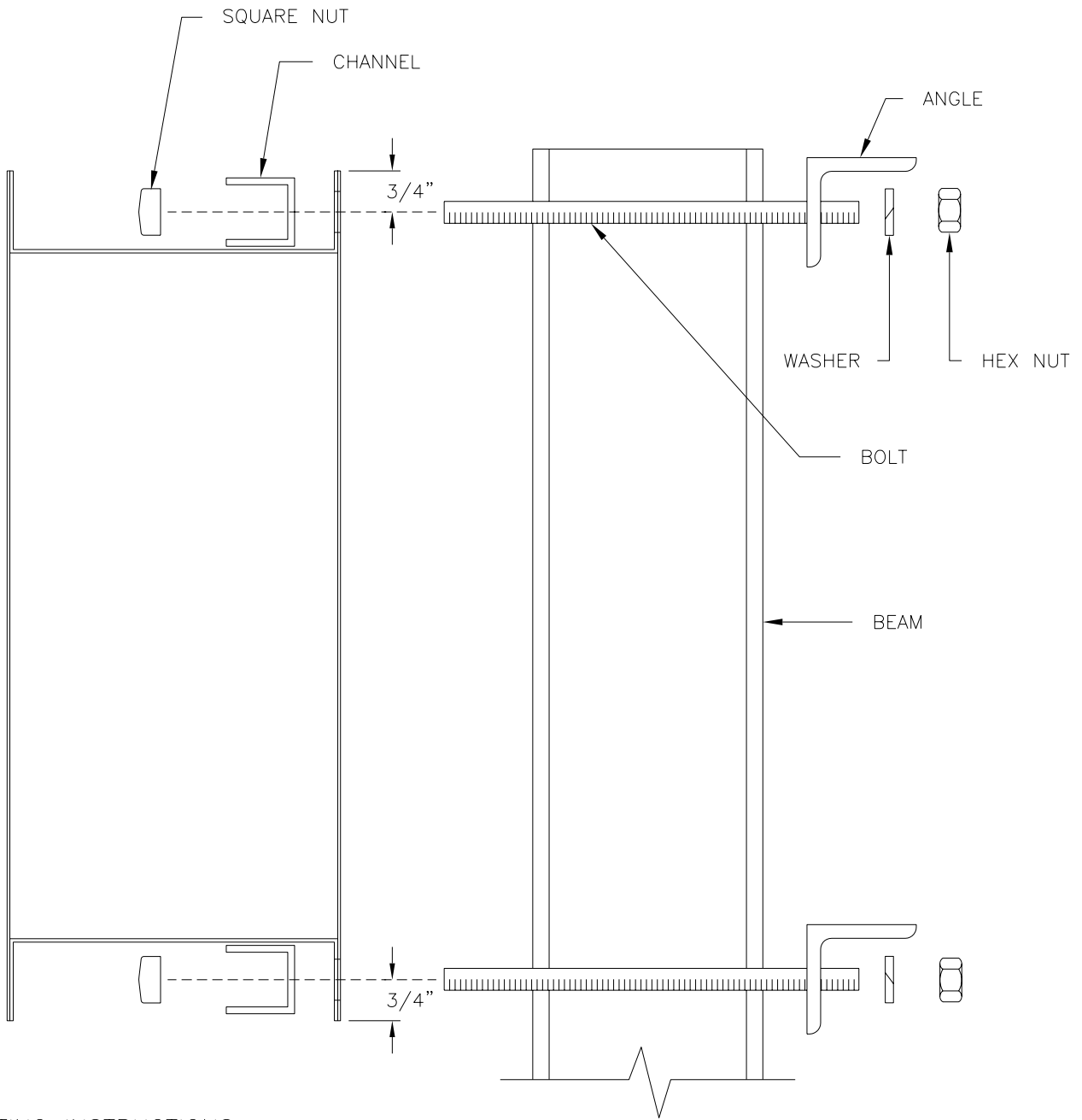

MOUNTING INSTRUCTIONS:

1. USE THE MOUNTING CHANNEL TO DETERMINE WHICH HOLE COMBINATION SHOULD BE USED. BE SURE TO KEEP THE BOLTS AS CLOSE TO THE BEAM AS POSSIBLE.
2. USING THE MOUNTING CHANNEL AS A TEMPLATE, DRILL 9/16" HOLES IN THE UPPER AND LOWER REAR FLANGE OF SCOREBOARD WHERE THE SUPPORTS WILL GO.
3. PLACE SQUARE NUTS INSIDE CHANNEL AND THREAD BOLTS THROUGH.
4. LIFT SCOREBOARD INTO POSITION WITH BOLTS STILL IN PLACE.
5. PLACE MOUNTING ANGLES OVER EACH PAIR OF BOLTS AND SECURE WITH LOCK WASHERS AND HEX NUTS.
6. WHEN SCOREBOARD IS ADJUSTED TO FINAL DESIRED POSITION, TIGHTEN HEX NUTS FIRMLY.

DAKTRONICS, INC. BROOKINGS, SD 57006	
PROJ: OUTDOOR SCOREBOARDS	
TITLE: SCOREBOARD MOUNTING	
DES. BY:	DRAWN BY: A VANBEMMEL DATE: 10FEB93
REVISION	APPR. BY: _____
	SCALE: NONE
1091-R10A-55101	

REV.	DATE	DESCRIPTION	BY	APPR.

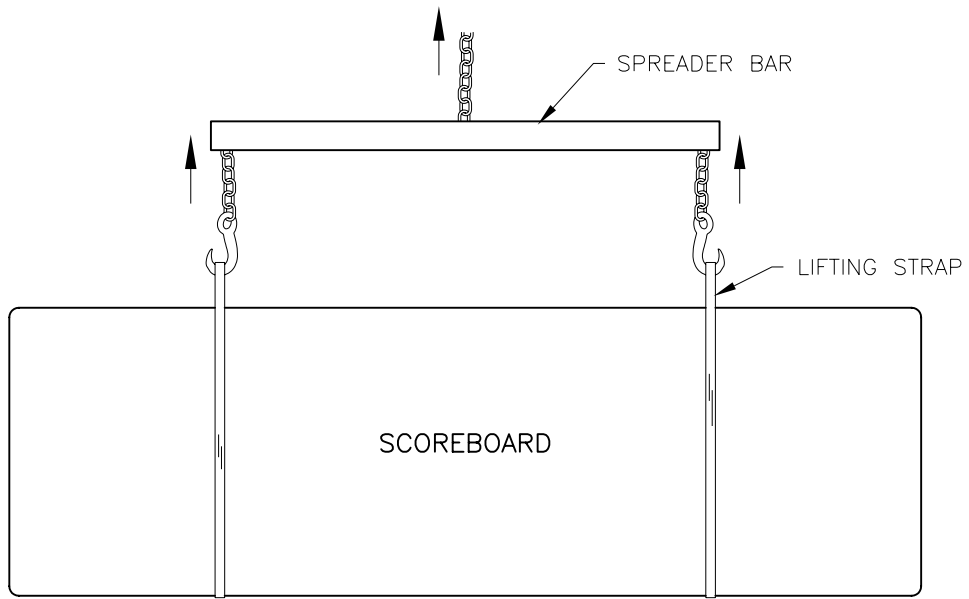

USE A SPREADER BAR SO THAT
THE FORCE ON THE LIFTING
STRAPS IS STRAIGHT UP.

DAKTRONICS, INC. BROOKINGS, SD 57006	
PROJ: OUTDOOR SCOREBOARDS	
TITLE: LIFTING SMALL BASEBALL SCOREBOARD	
DES. BY:	DRAWN BY: C FICKBOHM DATE: 29 SEP 93
REVISION	APPR. BY:
00	SCALE: NONE
1091-R10A-58668	

REV.	DATE	DESCRIPTION	BY	APPR.

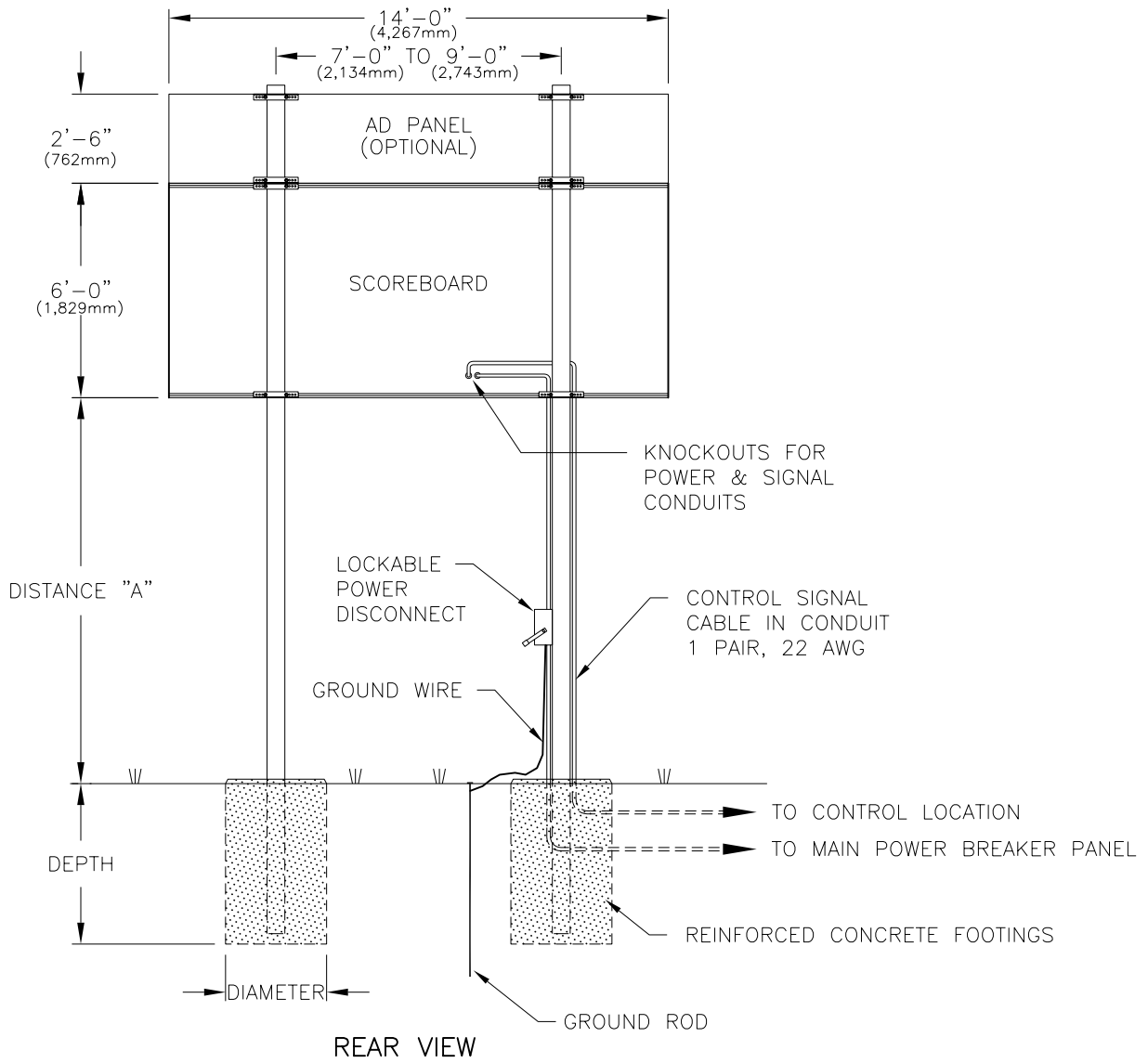

REAR VIEW

MODEL BA-1018 OR BA-2016 WITHOUT AD PANEL					
DISTANCE "A" (SEE FIGURE)	TOTAL DISPLAY SIZE		DESIGN WIND VELOCITY		
			70 MPH	80 MPH	100 MPH
10'-0"	14'-0" x 6'-0"	BEAM FOOTING	W5x19 3.0' x 4.6'	W6x20 3.0' x 5.0'	W8x28 3.0' x 5.9'
12'-0"	14'-0" x 6'-0"	BEAM FOOTING	W8x24 3.0' x 4.8'	W8x24 3.0' x 5.3'	W8x31 3.0' x 6.3'
14'-0"	14'-0" x 6'-0"	BEAM FOOTING	W8x24 3.0' x 5.0'	W8x28 3.0' x 5.5'	W8x35 3.0' x 6.5'

MODEL BA-1018 OR BA-2016 WITH 30"-HIGH AD PANEL					
DISTANCE "A" (SEE FIGURE)	TOTAL DISPLAY SIZE		DESIGN WIND VELOCITY		
			70 MPH	80 MPH	100 MPH
10'-0"	14'-0" x 8'-6"	BEAM FOOTING	W8x24 3.0' x 5.3'	W8x28 3.0' x 5.8'	W8x35 3.0' x 6.9'
12'-0"	14'-0" x 8'-6"	BEAM FOOTING	W8x28 3.0' x 5.6'	W8x31 3.0' x 6.1'	W10x39 3.0' x 7.2'
14'-0"	14'-0" x 8'-6"	BEAM FOOTING	W8x31 3.0' x 5.8'	W8x35 3.0' x 6.4'	W12x45 3.0' x 7.5'

FOOTING = DIAMETER X DEPTH

FOOTING DIMENSIONS ARE SUGGESTIONS ONLY, PROVIDED TO ASSIST WITH ESTIMATING INSTALLATION COSTS AND ARE NOT INTENDED FOR CONSTRUCTION PURPOSES.

FOOTING DIMENSIONS ARE BASED ON ASSUMED SOIL BEARING PRESSURE OF 2000 LB/FT²

ACTUAL FOOTING DEPTH AND DIAMETER FOR A PARTICULAR INSTALLATION MUST BE DETERMINED BY A QUALIFIED STRUCTURAL ENGINEER, USING DATA FROM A SOIL SAMPLE TEST AT THE SITE.

DAKTRONICS, INC. IS NOT RESPONSIBLE FOR STRUCTURES DESIGNED OR INSTALLED BY OTHERS.

02	20DEC00	REVISED COLUMN SECTIONS & FOOTINGS	MVD	
01	21MAR94	CORRECTED DISPLAY HEIGHT ON FIGURE.	AVB	AVB

REV.	DATE	DESCRIPTION	BY	APPR.
06	25 OCT 07	ADDED MILLIMETERS DIMENSIONS	KDD	
05	27 JAN 06	ADDED 30" TALL AD PANEL TO REAR VIEW.	KJB	
04	21 APR 05	ADDED BA-2016, BA-2017 TO DWG TITLE	MPM	
03	05MAY04	ADDED MODEL BA-2016	MCOPL	

THE CONCEPTS EXPRESSED AND DETAILS SHOWN ON THIS DRAWING ARE CONFIDENTIAL AND PROPRIETARY. DO NOT REPRODUCE BY ANY MEANS, INCLUDING ELECTRONICALLY WITHOUT THE EXPRESSED WRITTEN CONSENT OF DAKTRONICS, INC. COPYRIGHT 2004 DAKTRONICS, INC.

DAKTRONICS, INC. BROOKINGS, SD 57006

PROJ: OUTDOOR SCOREBOARDS

TITLE: INSTALLATION SPEC, BA-1018, BA-2016, BA-2017

DES. BY: AVB DRAWN BY: A VANBEMMEL DATE: 17MAR94

REVISION	APPR. BY:	1091-R10A-61904
06	SCALE: 1=60	

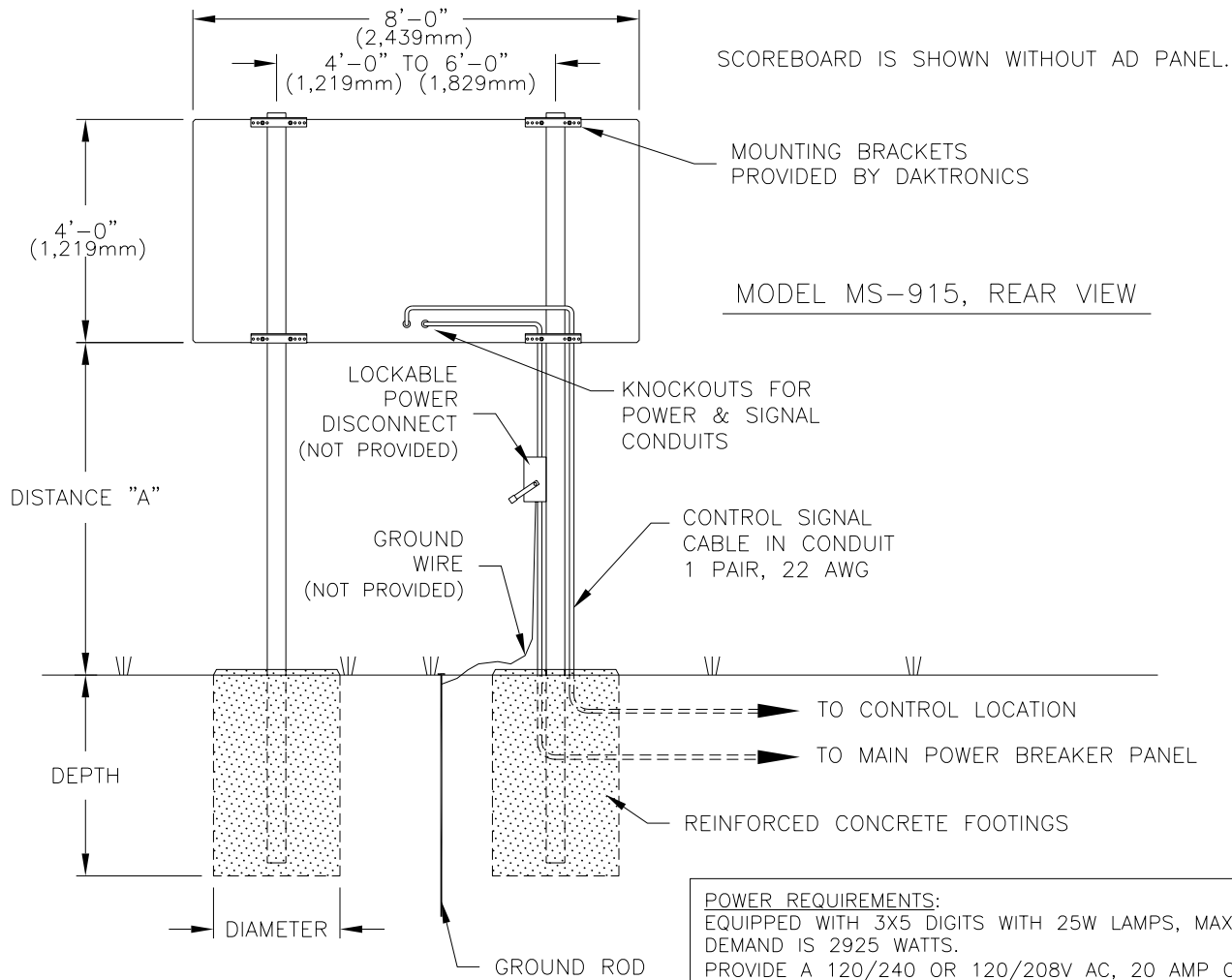

POWER REQUIREMENTS:
 EQUIPPED WITH 3X5 DIGITS WITH 25W LAMPS, MAX POWER DEMAND IS 2925 WATTS.
 PROVIDE A 120/240 OR 120/208V AC, 20 AMP CIRCUIT.
SIGNAL: 1 SHIELDED PAIR, 22 AWG MIN.

MODEL MS-915 WITHOUT AD PANEL					
DISTANCE "A" (SEE FIGURE)	TOTAL DISPLAY SIZE		DESIGN WIND VELOCITY		
			60 MPH	80 MPH	100 MPH
10'-0"	8'-0" x 4'-0"	BEAM FOOTING	W6x12 1.5' x 3.5'	W6x12 1.5' x 4.75'	W6x12 2' x 5'
12'-0"	8'-0" x 4'-0"	BEAM FOOTING	W6x12 1.5' x 3.75'	W6x12 2' x 4.5'	W6x12 2' x 5.5'
14'-0"	8'-0" x 4'-0"	BEAM FOOTING	W6x15.5 1.5' x 4'	W6x15.5 2' x 4.75'	W6x15.5 2' x 6'

MODEL MS-915 WITH 24"-HIGH HORIZONTAL AD PANEL					
DISTANCE "A" (SEE FIGURE)	TOTAL DISPLAY SIZE		DESIGN WIND VELOCITY		
			60 MPH	80 MPH	100 MPH
10'-0"	8'-0" x 6'-0"	BEAM FOOTING	W6x12 1.5' x 4'	W6x12 2' x 5'	W8x15 2' x 6'
12'-0"	8'-0" x 6'-0"	BEAM FOOTING	W6x12 1.5' x 4.5'	W6x15.5 2' x 5.25'	W8x17 2.5 x 6'
14'-0"	8'-0" x 6'-0"	BEAM FOOTING	W6x15.5 2' x 4.25'	W6x15.5 2' x 5.75'	W8x20 2.5' x 6.5'

BEAM SPEC EXAMPLE: W6X12 MEANS WIDE-FLANGE I-BEAM 6" DEEP, 12 LB PER FOOT.
 FOOTING = DIAMETER X DEPTH

FOOTING DIMENSIONS ARE SUGGESTIONS ONLY, PROVIDED TO ASSIST WITH ESTIMATING INSTALLATION COSTS AND ARE NOT INTENDED FOR CONSTRUCTION PURPOSES.
 FOOTING DIMENSIONS ARE BASED ON ASSUMED SOIL BEARING PRESSURE OF 3000 LB/SQ FT.
 ACTUAL FOOTING DEPTH AND DIAMETER FOR A PARTICULAR INSTALLATION MUST BE DETERMINED BY A QUALIFIED STRUCTURAL ENGINEER, USING DATA FROM A SOIL SAMPLE TEST AT THE SITE.

DAKTRONICS, INC. IS NOT RESPONSIBLE FOR STRUCTURES DESIGNED AND INSTALLED BY OTHERS.

DAKTRONICS, INC. BROOKINGS, SD 57006			
PROJ:			
TITLE: INSTALLATION SPECIFICATIONS, MS-915			
DES. BY:		DRAWN BY: A VANBEMMEL DATE: 17 MAR 99	
REVISION	APPR. BY:	1091-R08A-113568	
01	SCALE: 1=40		

REV.	DATE	DESCRIPTION	BY	APPR.
01	25 OCT 07	ADDED MILLIMETERS DIMENSIONS	KDD	

KEY: 0 = WIRE NOT CONNECTED 1 = WIRE IS CONNECTED

DECIMAL ADDRESS		PIN 12	PIN 11	PIN 9	PIN 8	PIN 6	PIN 5	PIN 3	PIN 2
1		0	0	0	0	0	0	0	1
2		0	0	0	0	0	0	0	1
3		0	0	0	0	0	0	0	1
4		0	0	0	0	0	0	1	0
5		0	0	0	0	0	0	1	0
6		0	0	0	0	0	0	1	0
7		0	0	0	0	0	0	1	0
8		0	0	0	0	0	0	0	0
9		0	0	0	0	0	1	0	0
10		0	0	0	0	0	0	0	0
11		0	0	0	0	0	1	1	0
12		0	0	0	0	0	1	0	0
13		0	0	0	0	0	1	0	1
14		0	0	0	0	1	1	1	0
15		0	0	0	0	1	1	1	1
16		0	0	0	1	0	0	0	0

DECIMAL ADDRESS		PIN 12	PIN 11	PIN 9	PIN 8	PIN 6	PIN 5	PIN 3	PIN 2
33		0	0	1	0	0	0	0	1
34		0	0	1	0	0	0	1	0
35		0	0	1	0	0	0	1	1
36		0	0	1	0	0	1	0	0
37		0	0	1	0	0	1	0	1
38		0	0	1	0	0	1	1	0
39		0	0	1	0	0	1	1	1
40		0	0	1	0	1	0	0	0
41		0	0	1	0	1	0	0	1
42		0	0	1	0	1	0	1	0
43		0	0	1	0	1	0	1	1
44		0	0	1	0	1	1	0	0
45		0	0	1	0	1	1	0	1
46		0	0	1	0	1	1	1	0
47		0	0	1	0	1	1	1	1
48		0	0	1	1	0	0	0	0

DECIMAL ADDRESS		PIN 12	PIN 11	PIN 9	PIN 8	PIN 6	PIN 5	PIN 3	PIN 2
65		0	1	0	0	0	0	0	1
66		0	1	0	0	0	0	1	0
67		0	1	0	0	0	0	1	1
68		0	1	0	0	0	1	0	0
69		0	1	0	0	0	1	0	1
70		0	1	0	0	0	1	1	0
71		0	1	0	0	0	1	1	1
72		0	1	0	0	0	1	0	0
73		0	1	0	0	1	0	0	1
74		0	1	0	0	1	0	1	0
75		0	1	0	0	1	0	1	1
76		0	1	0	0	1	1	0	0
77		0	1	0	0	1	1	0	1
78		0	1	0	0	1	1	1	0
79		0	1	0	0	1	1	1	1
80		0	1	0	1	0	0	0	0

DECIMAL ADDRESS		PIN 12	PIN 11	PIN 9	PIN 8	PIN 6	PIN 5	PIN 3	PIN 2
97		0	1	1	0	0	0	0	1
98		0	1	1	0	0	0	1	0
99		0	1	1	0	0	0	1	1
100		0	1	1	0	0	1	0	0
101		0	1	1	0	0	1	0	1
102		0	1	1	0	0	1	1	0
103		0	1	1	0	0	1	1	1
104		0	1	1	0	1	0	0	0
105		0	1	1	0	1	0	0	1
106		0	1	1	0	1	0	1	0
107		0	1	1	0	1	0	1	1
108		0	1	1	0	1	1	0	0
109		0	1	1	0	1	1	0	1
110		0	1	1	0	1	1	1	0
111		0	1	1	0	1	1	1	1
112		0	1	1	1	0	0	0	0

DECIMAL ADDRESS		PIN 12	PIN 11	PIN 9	PIN 8	PIN 6	PIN 5	PIN 3	PIN 2
17		0	0	0	1	0	0	0	1
18		0	0	0	1	0	0	1	0
19		0	0	0	1	0	0	1	1
20		0	0	0	1	0	1	0	0
21		0	0	0	1	0	1	0	1
22		0	0	0	1	0	1	1	0
23		0	0	0	1	0	1	1	1
24		0	0	0	1	1	0	0	0
25		0	0	0	1	1	0	0	1
26		0	0	0	1	1	0	1	0
27		0	0	0	1	1	0	1	1
28		0	0	0	1	1	1	0	0
29		0	0	0	1	1	1	0	1
30		0	0	0	1	1	1	1	0
31		0	0	0	1	1	1	1	1
32		0	0	1	0	0	0	0	0

DECIMAL ADDRESS		PIN 12	PIN 11	PIN 9	PIN 8	PIN 6	PIN 5	PIN 3	PIN 2
49		0	0	1	1	0	0	0	1
50		0	0	1	1	0	0	1	0
51		0	0	1	1	0	0	1	1
52		0	0	1	1	0	1	0	0
53		0	0	1	1	0	1	0	1
54		0	0	1	1	0	1	1	0
55		0	0	1	1	0	1	1	1
56		0	0	1	1	1	0	0	0
57		0	0	1	1	1	0	0	1
58		0	0	1	1	1	0	1	0
59		0	0	1	1	1	0	1	1
60		0	0	1	1	1	1	0	0
61		0	0	1	1	1	1	0	1
62		0	0	1	1	1	1	1	0
63		0	0	1	1	1	1	1	1
64		0	1	0	0	0	0	0	0

DECIMAL ADDRESS		PIN 12	PIN 11	PIN 9	PIN 8	PIN 6	PIN 5	PIN 3	PIN 2
81		0	1	0	1	0	0	0	1
82		0	1	0	1	0	0	1	0
83		0	1	0	1	0	0	1	1
84		0	1	0	1	0	1	0	0
85		0	1	0	1	0	1	0	1
86		0	1	0	1	0	1	1	0
87		0	1	0	1	0	1	1	1
88		0	1	0	1	1	0	0	0
89		0	1	0	1	1	0	0	1
90		0	1	0	1	1	0	1	0
91		0	1	0	1	1	0	1	1
92		0	1	0	1	1	1	0	0
93		0	1	0	1	1	1	0	1
94		0	1	0	1	1	1	1	0
95		0	1	0	1	1	1	1	1
96		0	1	1	0	0	0	0	0

DECIMAL ADDRESS		PIN 12	PIN 11	PIN 9	PIN 8	PIN 6	PIN 5	PIN 3	PIN 2
113		0	1	1	1	0	0	0	1
114		0	1	1	1	0	0	1	0
115		0	1	1	1	0	0	1	1
116		0	1	1	1	0	1	0	0
117		0	1	1	1	0	1	0	1
118		0	1	1	1	0	1	1	0
119		0	1	1	1	0	1	1	1
120		0	1	1	1	1	0	0	0
121		0	1	1	1	1	0	0	1
122		0	1	1	1	1	0	1	0
123		0	1	1	1	1	0	1	1
124		0	1	1	1	1	1	0	0
125		0	1	1	1	1	1	0	1
126		0	1	1	1	1	1	1	0
127		0	1	1	1	1	1	1	1
128		1	0	0	0	0	0	0	0

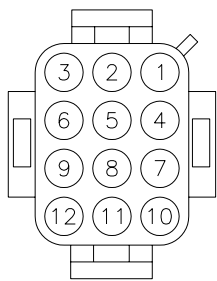

ADDRESS PLUG WIRE SIDE

WIRING DIAGRAM
ADDRESS PLUG
WITH ALL WIRES
CONNECTED

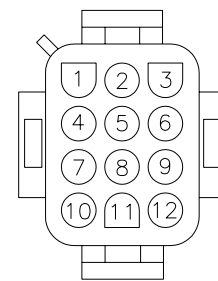

BOTTOM VIEW

DAKTRONICS, INC. BROOKINGS, SD 57006

PROJ:	
TITLE:	ADDRESS TABLE, 1 THROUGH 128
DES. BY:	AVB
DRAWN BY:	A VANBEMMEL
DATE:	28 APR 99
REVISION	APPR. BY:
01	NONE
1150-R04A-115078	

01	08 MAR 05	ADDED BOTTOM VIEW	KQB	
REV.	DATE	DESCRIPTION	BY	APPR.

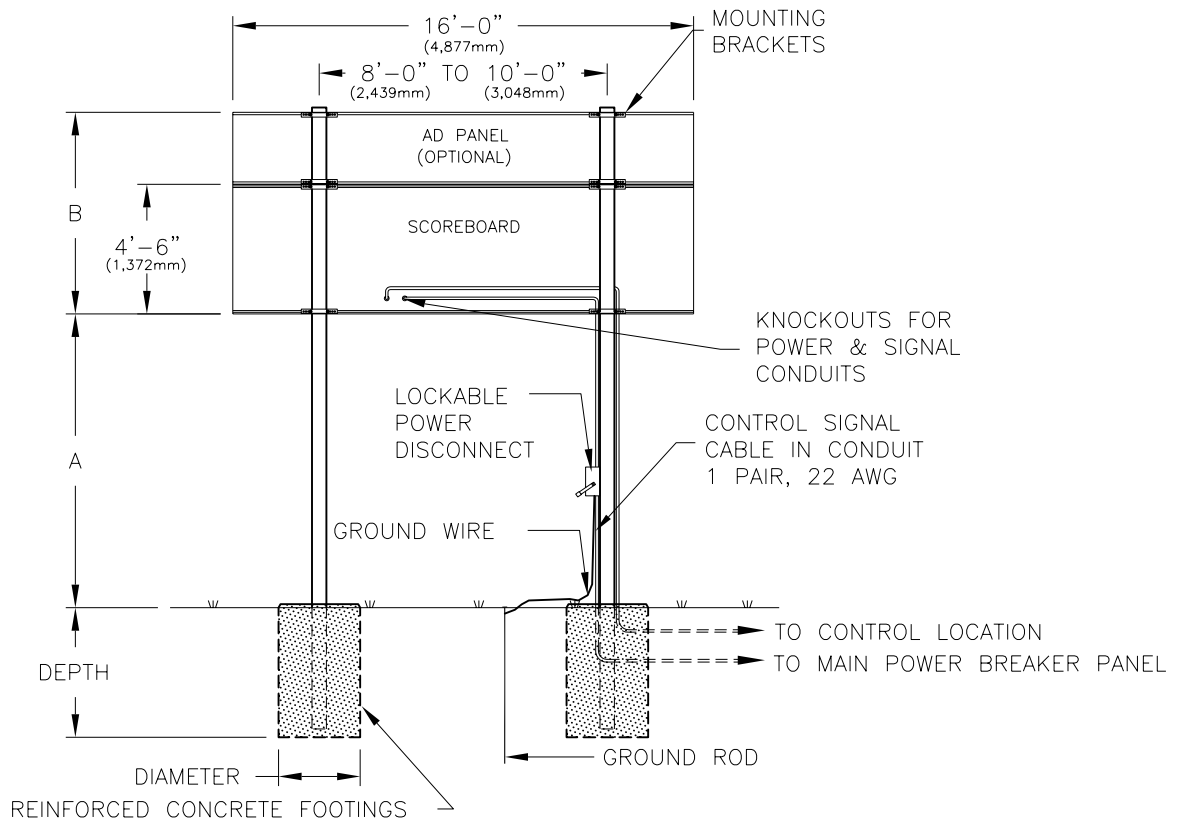

REAR VIEW
MS-2002

ELECTRICAL

POWER CABLE MUST HAVE A SEPARATE GROUND CONDUCTOR. SCOREBOARD MUST BE CONNECTED TO A GROUND ROD AT SCOREBOARD LOCATION.

MODEL MS-2002						
VERTICAL DISTANCE (A)	AD PANEL HEIGHT	COMBINED HEIGHT (B)		DESIGN WIND VELOCITY		
				70 MPH	80 MPH	100 MPH
10 FT	NONE	4'-6"	BEAM	W6x15	W5x19	W8x24
			FOOTING	3.0'x4.3'	3.0'x4.7'	3.0'x5.6'
	2 FT	6'-6"	BEAM	W6x20	W8x24	W8x31
			FOOTING	3.0'x5.0'	3.0'x5.5'	3.0'x6.4'
	4 FT	8'-6"	BEAM	W8x28	W8x31	W8x35
			FOOTING	3.0'x5.5'	3.0'x6.1'	3.0'x7.2'
12 FT	NONE	4'-6"	BEAM	W5x19	W8x24	W8x28
			FOOTING	3.0'x4.5'	3.0'x5.0'	3.0'x5.9'
	2 FT	6'-6"	BEAM	W8x24	W8x28	W10x33
			FOOTING	3.0'x5.2'	3.0'x5.7'	3.0'x6.8'
	4 FT	8'-6"	BEAM	W8x31	W10x33	W8x40
			FOOTING	3.0'x5.8'	3.0'x6.4'	3.0'x7.5'
14 FT	NONE	4'-6"	BEAM	W8x24	W8x24	W8x31
			FOOTING	3.0'x4.8'	3.0'x5.2'	3.0'x6.2'
	2 FT	6'-6"	BEAM	W8x28	W8x31	W10x39
			FOOTING	3.0'x5.4'	3.0'x6.0'	3.0'x7.0'
	4 FT	8'-6"	BEAM	W10x33	W10x39	W8x48
			FOOTING	3.0'x6.1'	3.0'x6.7'	3.0'x7.9'

FOOTING = DIAMETER X DEPTH

FOOTING DIMENSIONS ARE SUGGESTIONS ONLY, PROVIDED TO ASSIST WITH ESTIMATING INSTALLATION COSTS, AND ARE NOT INTENDED FOR CONSTRUCTION PURPOSES.

COLUMNS AND FOOTINGS MUST BE DESIGNED BY A STATE LICENCED ENGINEER. DAKTRONICS DOES NOT ASSUME ANY LIABILITY FOR ANY INSTALLATIONS DERIVED FROM THIS INFORMATION OR DESIGNED AND INSTALLED BY OTHERS.

A NOTE ABOUT BEAM NOMENCLATURE:

For a typical beam, W12x30 for example, "W" stands for "Wide-Flange Beam". The first number (12) is the approximate front to rear dimension of the beam in inches. The second number (30) is the weight per foot in pounds. This numbering is standard in the steel industry. Widths vary from 4 to 8 inches in this chart.

REV.	DATE	DESCRIPTION	BY	APPR.
03	25 OCT 07	ADDED MILLIMETERS DIMENSIONS	KDD	
02	17 OCT 07	REMOVED FAN HOODS FOR TNMC'S	KDD	
1	20DEC00	REVISED COLUMN SECTIONS & FOOTINGS	MVD	

DAKTRONICS, INC. BROOKINGS, SD 57006			
PROJ: OUTDOOR INCANDESCENT SCOREBOARDS			
TITLE: INSTALLATION SPECIFICATIONS, MS-2002			
DES. BY: BPETERSON		DRAWN BY: MVANDYK	
		DATE: 31JAN00	
REVISION	APPR. BY:	1091-R10A-127195	
03	SCALE: 1=80		

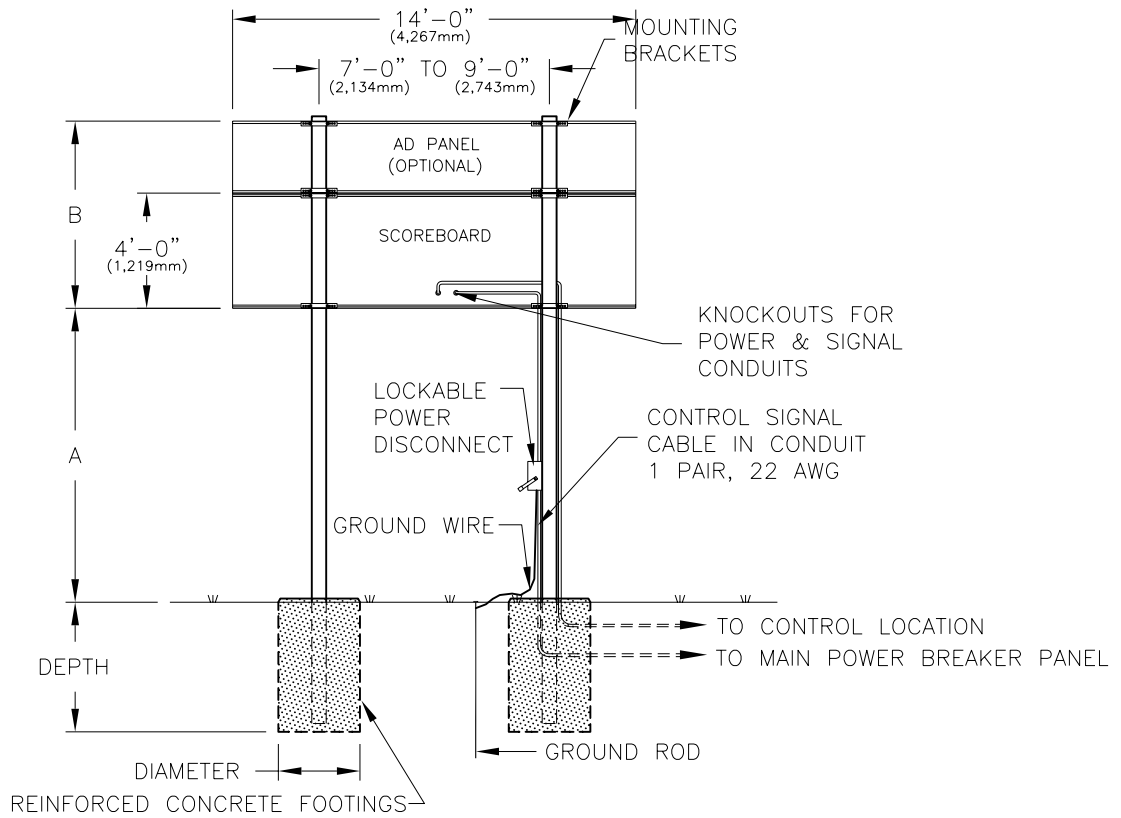

REAR VIEW

ELECTRICAL

FB-824 & SO-824

POWER CABLE MUST HAVE A SEPERATE GROUND CONDUCTOR. SCOREBOARD MUST BE CONNECTED TO A GROUND ROD AT SCOREBOARD LOCATION.

FOOTING DIMENSIONS ARE SUGGESTIONS ONLY, PROVIDED TO ASSIST WITH ESTIMATING INSTALLATION COSTS, AND ARE NOT INTENDED FOR CONSTRUCTION PURPOSES.

COLUMNS AND FOOTINGS MUST BE DESIGNED BY A STATE LICENCED ENGINEER. DAKTRONICS DOES NOT ASSUME ANY LIABILITY FOR ANY INSTALLATIONS DERIVED FROM THIS INFORMATION OR DESIGNED AND INSTALLED BY OTHERS.

MODEL FB-824 & SO-824						
VERTICAL DISTANCE (A)	AD PANEL HEIGHT	COMBINED HEIGHT (B)		DESIGN WIND VELOCITY		
				70 MPH	80 MPH	100 MPH
10 FT	NONE	4'-0"	BEAM	W6x15	W6x15	W5x19
			FOOTING	3.0'x3.9'	3.0'x4.3'	3.0'x5.1'
	2 FT	6'-0"	BEAM	W5x19	W6x20	W8x28
			FOOTING	3.0'x4.6'	3.0'x5.0'	3.0'x5.9'
4 FT	8'-0"	BEAM	W8x24	W8x28	W8x31	
		FOOTING	3.0'x5.2'	3.0'x5.7'	3.0'x6.7'	
12 FT	NONE	4'-0"	BEAM	W5x16	W5x19	W8x24
			FOOTING	3.0'x4.1'	3.0'x4.5'	3.0'x5.3'
	2 FT	6'-0"	BEAM	W8x24	W8x24	W8x31
			FOOTING	3.0'x4.8'	3.0'x5.3'	3.0'x6.3'
4 FT	8'-0"	BEAM	W8x28	W8x31	W10x39	
		FOOTING	3.0'x5.4'	3.0'x5.9'	3.0'x7.0'	
14 FT	NONE	4'-0"	BEAM	W5x19	W8x24	W8x28
			FOOTING	3.0'x4.4'	3.0'x4.8'	3.0'x5.7'
	2 FT	6'-0"	BEAM	W8x24	W8x28	W8x35
			FOOTING	3.0'x5.0'	3.0'x5.5'	3.0'x6.5'
4 FT	8'-0"	BEAM	W8x31	W8x35	W12x45	
		FOOTING	3.0'x5.7'	3.0'x6.2'	3.0'x7.3'	

FOOTING = DIAMETER X DEPTH

A NOTE ABOUT BEAM NOMENCLATURE:

For a typical beam, W12x30 for example, "W" stands for "Wide-Flange Beam". The first number (12) is the approximate front to rear dimension of the beam in inches. The second number (30) is the weight per foot in pounds. This numbering is standard in the steel industry. Widths vary from 4 to 8 inches in this chart.

REV.	DATE	DESCRIPTION	BY	APPR.
02	25 OCT 07	ADDED MILLIMETERS DIMENSIONS	KDD	
1	20DEC00	REVISED COLUMN SECTIONS & FOOTINGS	MVD	

DAKTRONICS, INC. BROOKINGS, SD 57006			
PROJ: OUTDOOR INCANDESCENT SCOREBOARDS			
TITLE: INSTALLATION SPECIFICATIONS, FB-824 & SO-824			
DES. BY: BPETERSON		DRAWN BY: BPETERSON	
		DATE: 02FEB00	
REVISION	APPR. BY:	1091-R10A-127287	
02	SCALE: 1=80		

0A-1091-1214
12V TRUMPET HORN PLATE ASSY

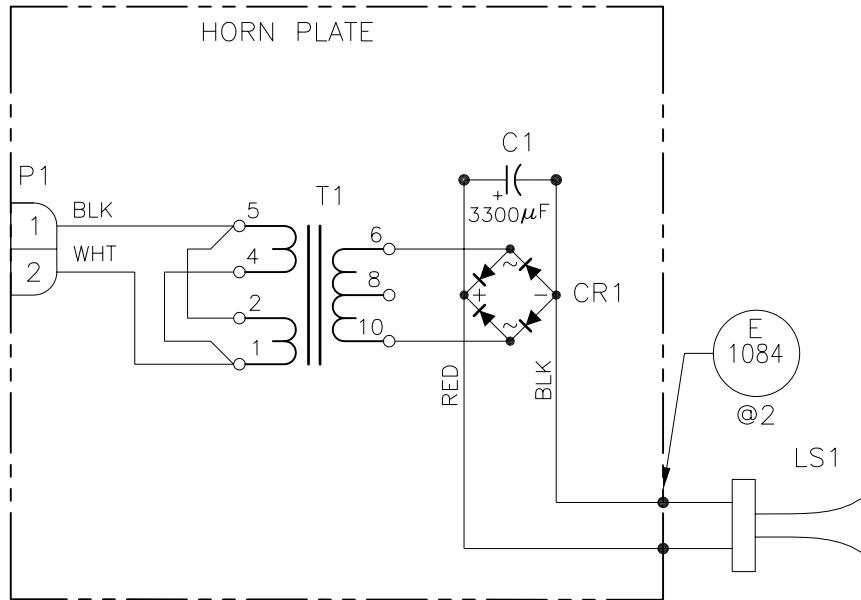

BEFORE APRIL 2006

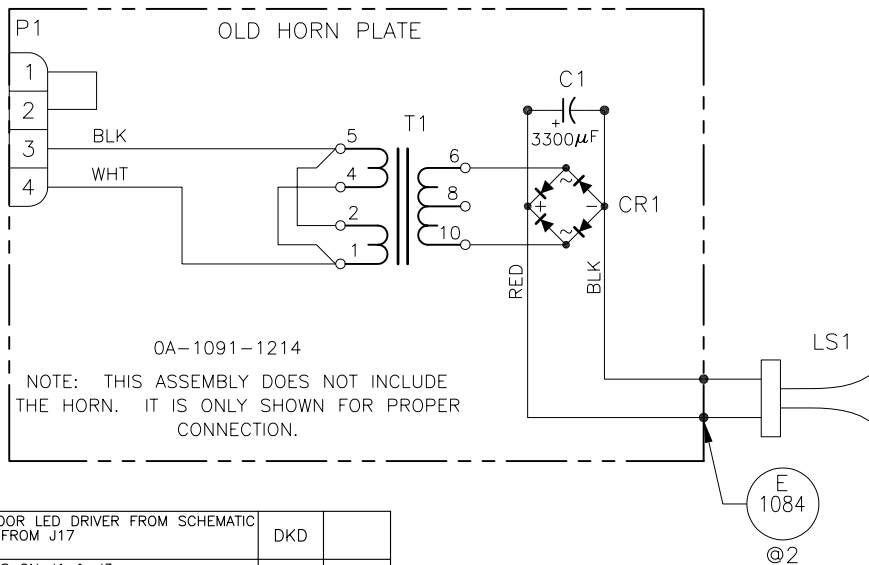

05	13 APR 07	REMOVED OUTDOOR LED DRIVER FROM SCHEMATIC REMOVED WIRE FROM J17	DKD	
04	11 SEPT 06	CHANGED LABELS ON J1 & J3, REMOVED WIRE FROM J17	AMG	
03	5/23/06	CORRECTED CAP LABEL FROM C-1115 TO C-1158	SJC	
02	23 MAR 06	ADDED SOLIDSTATE HORN RELAY ASSY TO -1214.	DMD	
01	18 MAY 01	PART NUMBER WAS CHANGED FROM -1213 TO -1214.	MWM	
REV.	DATE	DESCRIPTION	BY	APPR.

DAKTRONICS, INC. BROOKINGS, SD 57006	
PROJ:	STANDARD SCOREBOARDS
TITLE:	SCHEMATIC, OUTDOOR SCBD 12VDC TRUMPET HORN, AS5K
DES. BY:	DRAWN BY: JCM
	DATE: 06MAR00
REVISION	APPR. BY:
05	NONE
1091-R03A-128938	

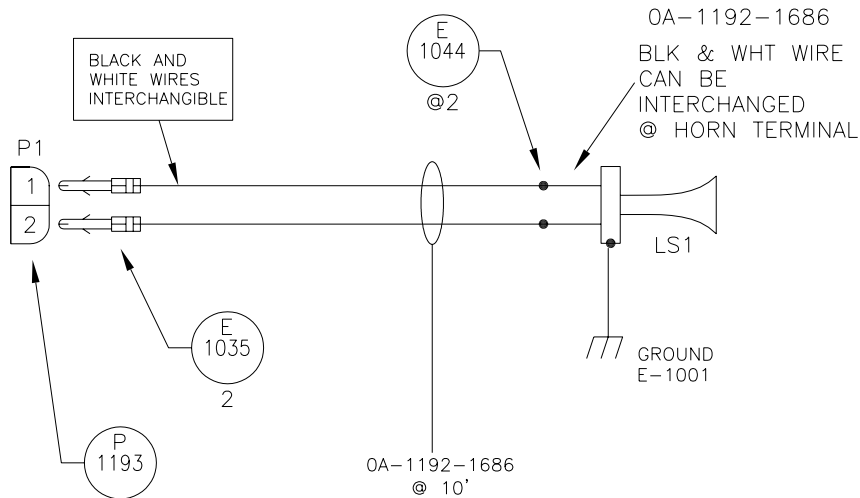

SCOREBOARDS BUILT BEFORE APRIL 2006

OA-1091-0469
OA-1192-1112

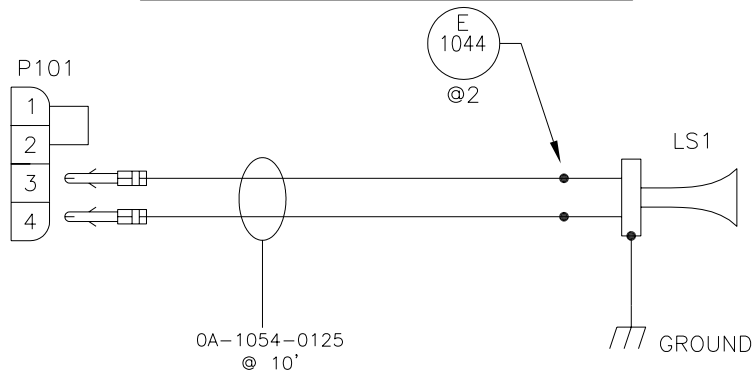

06	13 APR 07	UPDATED NOTES, CHANGED LABEL ON J1 & J3, REMOVED WIRE FROM J17.	AMG	
05	11 SEPT 06	UPDATED NOTES, CHANGED LABEL ON J1 & J3, REMOVED WIRE FROM J17.	AMG	
04	8/3/06	ADDED COMMIT TO WIRE OA-1054-0125 PER ECO 046876	BDV	
03	30 JUN 06	CHANGED WIRES FROM W-1100 & W-1092 TO CABLE OA-1054-0125 PER ECO 49671	AFL	
02	23 MAR 06	ADDED OA-1192-1686 TO AND SOLIDSTATE HORN KIT	DMD	
01	07SEP00	ADDED GND WIRE TO ASSEMBLY	CMC	
REV.	DATE	DESCRIPTION	BY	APPR.

THE CONCEPTS EXPRESSED AND DETAILS SHOWN ON THIS DRAWING ARE CONFIDENTIAL AND PROPRIETARY. DO NOT REPRODUCE BY ANY MEANS, INCLUDING ELECTRONICALLY WITHOUT THE EXPRESSED WRITTEN CONSENT OF DAKTRONICS, INC. COPYRIGHT 2006 DAKTRONICS, INC.

DAKTRONICS, INC. BROOKINGS, SD 57006

PROJ: STANDARD OUTDOOR SCOREBOARDS
TITLE: SCHEMATIC; 120VAC TRUMPET HORN

DES. BY: DRAWN BY: RASMUS DATE: 16MAY00

REVISION	APPR. BY:	1091-R03A-132173
06	SCALE: 1=1	

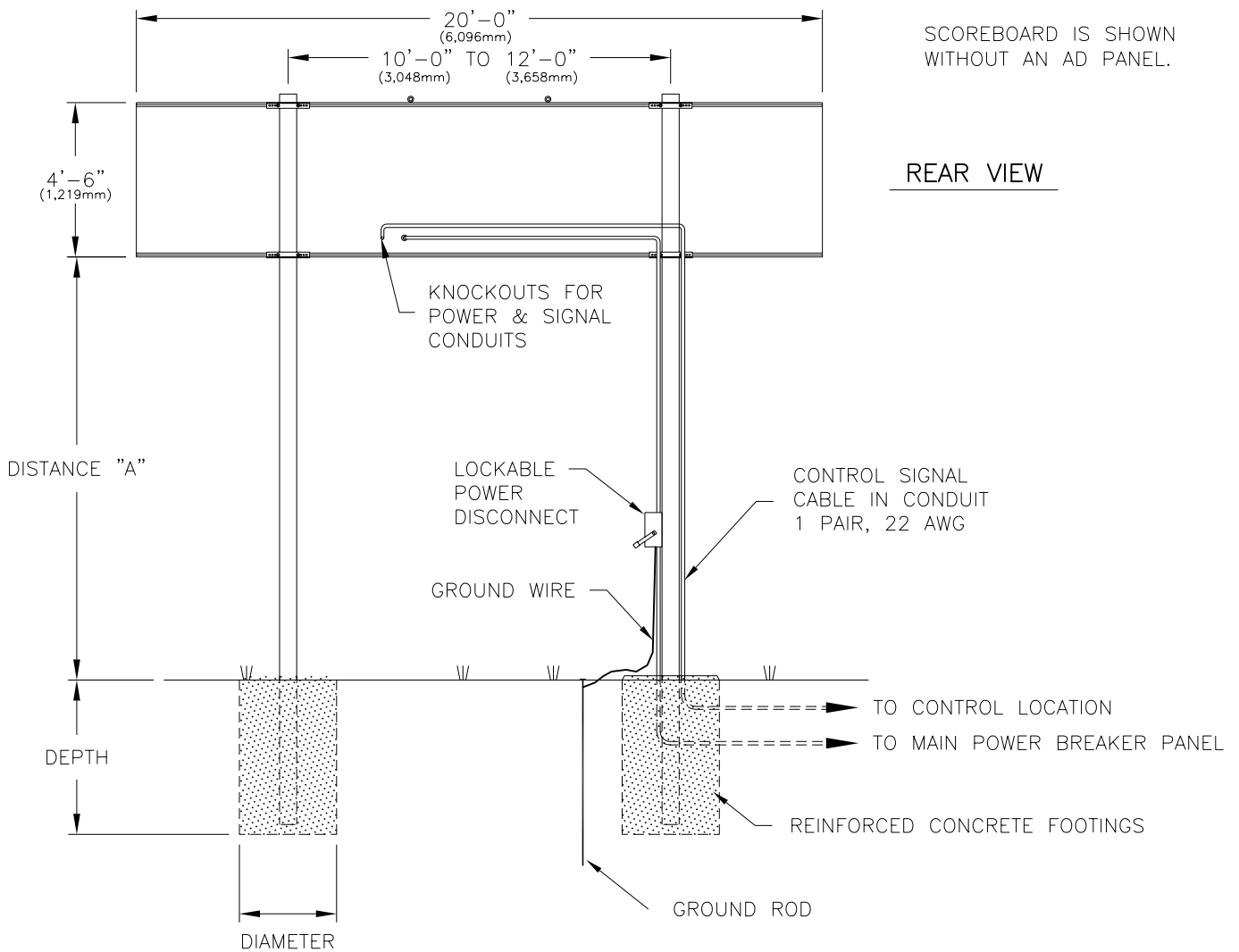

SCOREBOARD IS SHOWN WITHOUT AN AD PANEL.

REAR VIEW

MODEL MS-2011 WITHOUT AD PANEL					
DISTANCE "A" (SEE FIGURE)	TOTAL DISPLAY SIZE		DESIGN WIND VELOCITY		
			70 MPH	80 MPH	100 MPH
10'-0"	16'-0" x 6'-0"	BEAM FOOTING	W10X15 3.0' x 5.3'	W6X16 3.0' x 5.9'	W8X18 3.0' x 7.0'
12'-0"	16'-0" x 6'-0"	BEAM FOOTING	W8X18 3.0' x 5.8'	W8X18 3.0' x 6.4'	W10X22 3.0' x 7.6'
14'-0"	16'-0" x 6'-0"	BEAM FOOTING	W8X18 3.0' x 5.9'	W8X21 3.0' x 6.5'	W16X26 3.0' x 7.7'

MODEL MS-2011 WITH 30"-HIGH AD PANEL					
DISTANCE "A" (SEE FIGURE)	TOTAL DISPLAY SIZE		DESIGN WIND VELOCITY		
			70 MPH	80 MPH	100 MPH
10'-0"	16'-0" x 8'-6"	BEAM FOOTING	W8X18 3.0' x 6.4'	W8X21 3.0' x 7.1'	W12X26 3.0' x 8.4'
12'-0"	16'-0" x 8'-6"	BEAM FOOTING	W8X21 3.0' x 6.7'	W8X24 3.0' x 7.4'	W12X26 3.0' x 8.7'
14'-0"	16'-0" x 8'-6"	BEAM FOOTING	W8X24 3.0' x 7.0'	W12X26 3.0' x 7.7'	W10X33 3.0' x 9.1'

FOOTING = DIAMETER X DEPTH

FOOTING DIMENSIONS ARE SUGGESTIONS ONLY, PROVIDED TO ASSIST WITH ESTIMATING INSTALLATION COSTS AND ARE NOT INTENDED FOR CONSTRUCTION PURPOSES.

FOOTING DIMENSIONS ARE BASED ON ASSUMED SOIL BEARING PRESSURE OF 2000 LB/FT² (UBC SOIL CLASS 3)

DESIGN WIND VELOCITY BASED ON UBC CODE (1997)

ACTUAL FOOTING DEPTH AND DIAMETER FOR A PARTICULAR INSTALLATION MUST BE DETERMINED BY A QUALIFIED STRUCTURAL ENGINEER, USING DATA FROM A SOIL SAMPLE TEST AT THE SITE.

DAKTRONICS, INC. IS NOT RESPONSIBLE FOR STRUCTURES DESIGNED AND INSTALLED BY OTHERS.

REV.	DATE	DESCRIPTION	BY	APPR.
03	25 OCT 07	ADDED MILLIMETERS DIMENSIONS	KDD	
02	17 OCT 07	REMOVED TNMCS	KDD	
01	9 NOV 05	CHANGED POLE SPACING TO 10' - 12'	JKU	

DAKTRONICS, INC. BROOKINGS, SD 57006			
PROJ: OUTDOOR SCOREBOARDS			
TITLE: INSTALLATION SPECIFICATIONS; MS-2011 W/ TNMC			
DES. BY: MCOPLAN		DRAWN BY: MCOPLAN	
		DATE: 14JUN01	
REVISION	APPR. BY:	1091-R10A-135414	
03	SCALE: 1=60		

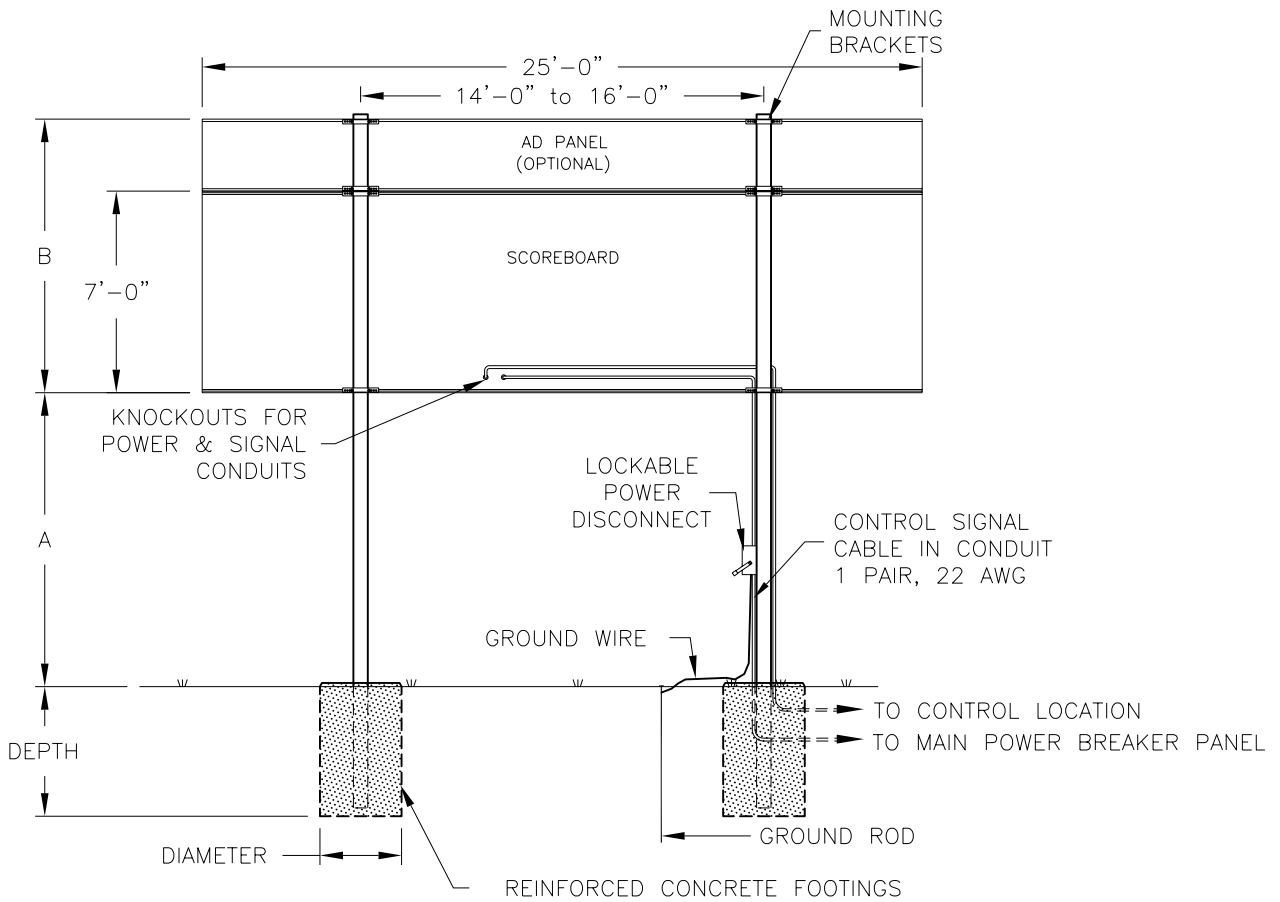

REAR VIEW

MS-2006

ELECTRICAL

POWER CABLE MUST HAVE A SEPERATE GROUND CONDUCTOR. SCOREBOARD MUST BE CONNECTED TO A GROUND ROD AT SCOREBOARD LOCATION.

FOOTING DIMENSIONS ARE SUGGESTIONS ONLY, PROVIDED TO ASSIST WITH ESTIMATING INSTALLATION COSTS, AND ARE NOT INTENDED FOR CONSTRUCTION PURPOSES.

COLUMNS AND FOOTINGS MUST BE DESIGNED BY A STATE LICENCED ENGINEER. DAKTRONICS DOES NOT ASSUME ANY LIABILITY FOR ANY INSTALLATIONS DERIVED FROM THIS INFORMATION OR DESIGNED AND INSTALLED BY OTHERS.

A NOTE ABOUT BEAM NOMENCLATURE:

For a typical beam, W12x30 for example, "W" stands for "Wide-Flange Beam". The first number (12) is the approximate front to rear dimension of the beam in inches. The second number (30) is the weight per foot in pounds. This numbering is standard in the steel industry. Widths vary from 4 to 8 inches in this chart.

MODEL MS-2006						
VERTICAL DISTANCE (A)	AD PANEL HEIGHT	COMBINED HEIGHT (B)		DESIGN WIND VELOCITY		
				70 MPH	80 MPH	100 MPH
10 FT	NONE	7'-0"	BEAM	W8x28	W8x31	W10x39
			FOOTING	3'x6'	3'x6.6'	3'x7.8'
	2 FT	9'-0"	BEAM	W10x33	W10x39	W8x48
			FOOTING	3'x6.7'	3'x7.4'	3'x8.7'
4 FT	11'-0"	BEAM	W8x40	W8x48	W10x54	
		FOOTING	3'x7.3'	3'x8.1'	3'x9.6'	
12 FT	NONE	7'-0"	BEAM	W8x31	W8x35	W12x45
			FOOTING	3'x6.2'	3'x6.9'	3'x8.1'
	2 FT	9'-0"	BEAM	W10x39	W12x45	W12x53
			FOOTING	3'x7'	3'x7.7'	3'x9'
4 FT	11'-0"	BEAM	W10x45	W10x49	W12x65	
		FOOTING	3'x7.6'	3'x8.4'	3'x9.9'	
14 FT	NONE	7'-0"	BEAM	W8x35	W8x40	W8x48
			FOOTING	3'x6.5'	3'x7.2'	3'x8.5'
	2 FT	9'-0"	BEAM	W12x45	W8x48	W10x60
			FOOTING	3'x7.3'	3'x8'	3'x9.5'
4 FT	11'-0"	BEAM	W10x49	W12x58	W12x72	
		FOOTING	3'x7.9'	3'x8.7'	3'x10.3'	

FOOTING = DIAMETER X DEPTH

REV.	DATE	DESCRIPTION	BY	APPR.
03	17 OCT 07	REMOVED TNMC'S	KDD	
02	9 NOV 05	CHANGED POLE SPACING TO 14' - 16'.	JKU	
01	08 SEPT 05	CHANGED POLE SPACING FROM 14'-12' TO 14'-16'	CAC	

DAKTRONICS, INC. BROOKINGS, SD 57006			
PROJ: OUTDOOR INCANDESCENT SCOREBOARDS			
TITLE: INSTALLATION SPECIFICATIONS, MS-2006			
DES. BY: GBREEN		DRAWN BY: GBREEN	
		DATE: 21JUL00	
REVISION	APPR. BY:	1091-R10A-135575	
03	SCALE: 1=80		

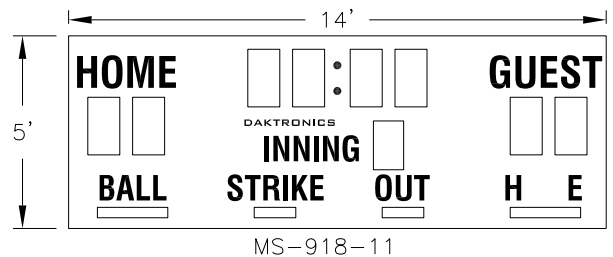
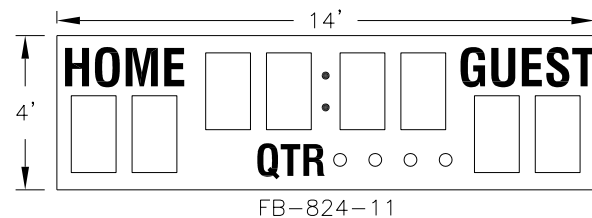
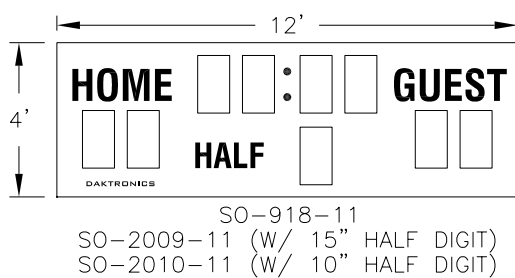
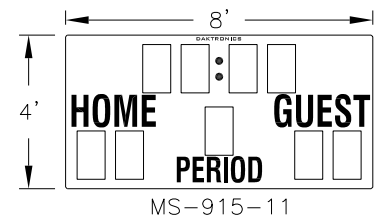
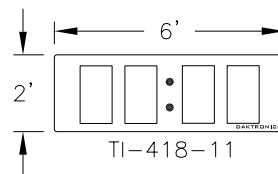
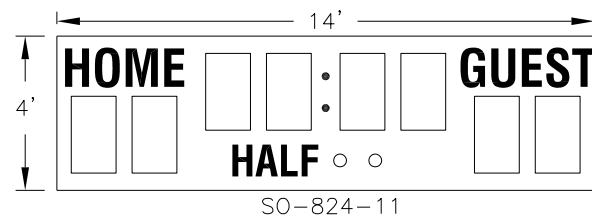
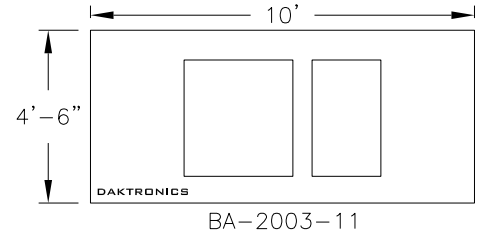
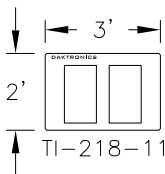
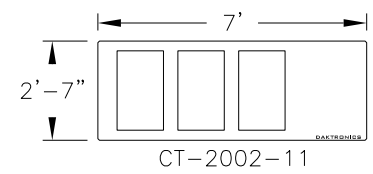
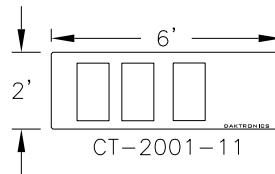
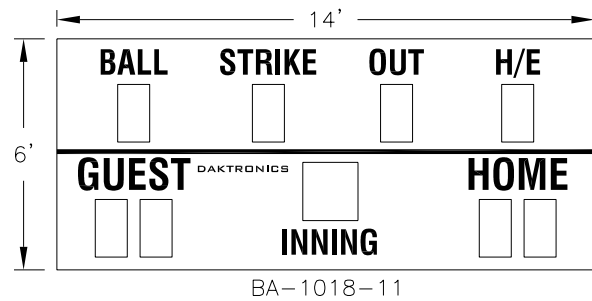
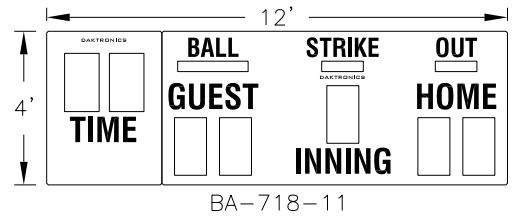
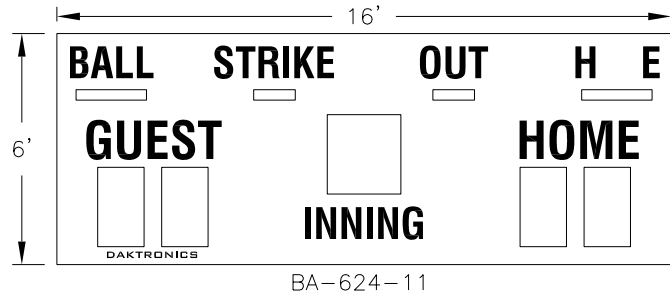
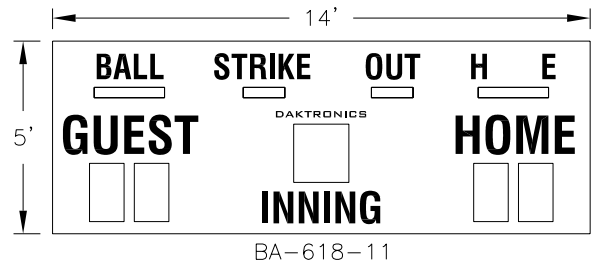
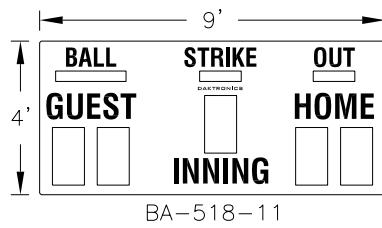
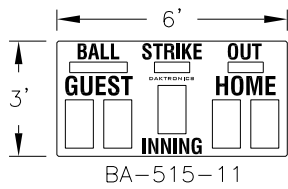

THE CONCEPTS EXPRESSED AND DETAILS SHOWN ON THIS DRAWING ARE CONFIDENTIAL AND PROPRIETARY. DO NOT REPRODUCE BY ANY MEANS, INCLUDING ELECTRONICALLY WITHOUT THE EXPRESSED WRITTEN CONSENT OF DAKTRONICS, INC. COPYRIGHT 2002 DAKTRONICS, INC.

REV.	DATE	DESCRIPTION	BY	APPR.
03	29 AUG 02	ADDED MODEL BA-2003-11	MCOPL	
02	20 AUG 02	ADDED MODELS SO-2009-11 AND SO-2010-11	MCOPL	
01	24 JUL 01	ADDED "-11" TO MODEL NUMBERS	MCOPL	

DAKTRONICS, INC. BROOKINGS, SD 57006	
PROJ: OUTDOOR LED SCOREBOARDS	
TITLE: SINGLE SECTION LED SCOREBOARD MODELS	
DES. BY: BPETERSON	DRAWN BY: JNILSEN
DATE: 09JAN01	
REVISION	APPR. BY:
03	SCALE: 1=60
1192-E10A-142912	

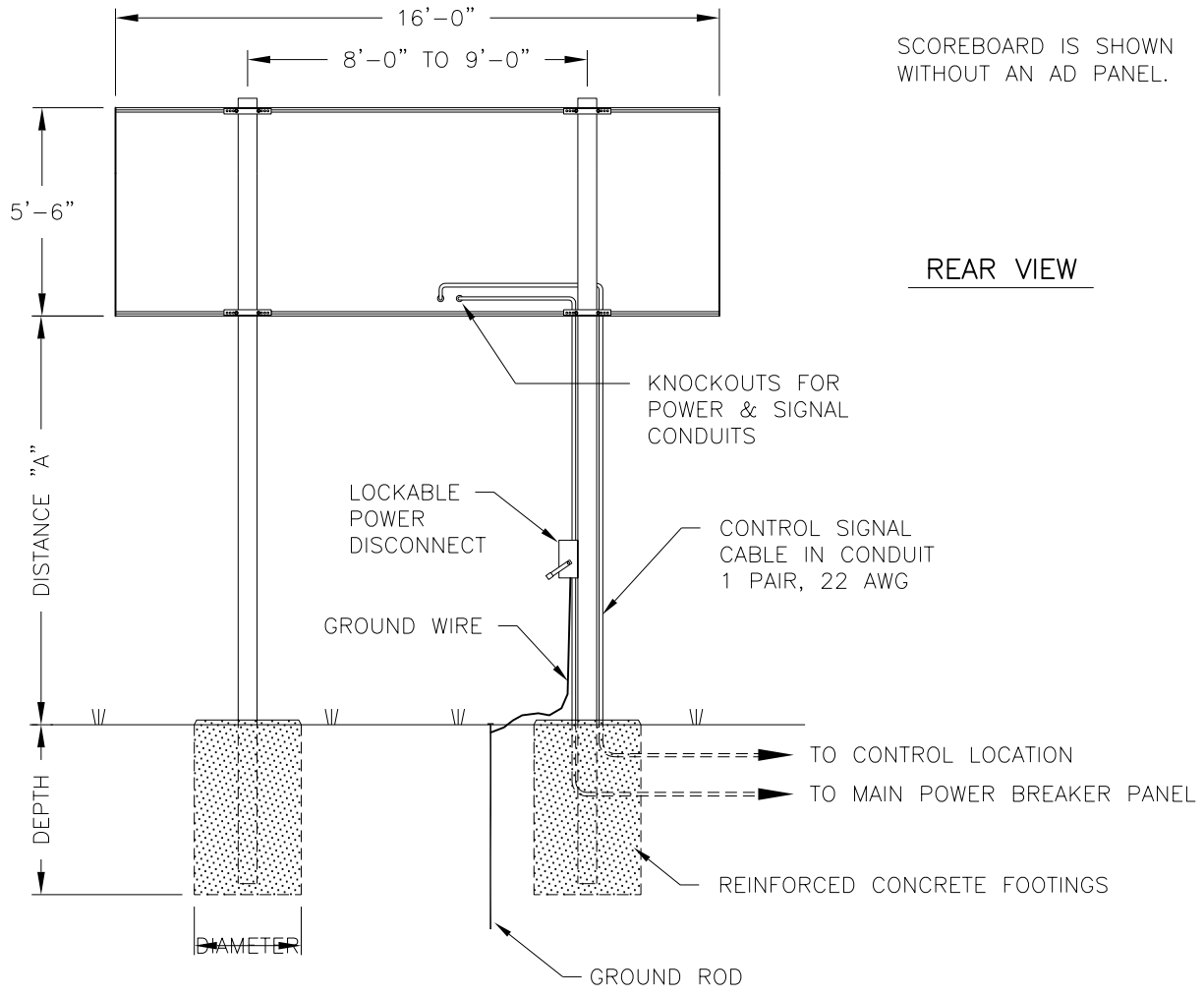

REAR VIEW

SCOREBOARD IS SHOWN WITHOUT AN AD PANEL.

MODEL SO-2008 WITHOUT AD PANEL					
DISTANCE "A" (SEE FIGURE)	TOTAL DISPLAY SIZE		DESIGN WIND VELOCITY		
			70 MPH	80 MPH	100 MPH
10'-0"	16'-0" x 5'-6"	BEAM FOOTING	W6x15 2.0' x 6.2'	W8x18 2.0' x 6.9'	W8x18 2.0' x 8.1'
12'-0"	16'-0" x 5'-6"	BEAM FOOTING	W8x18 2.0' x 6.5'	W8x18 2.0' x 7.2'	W10x22 2.5' x 7.8'
14'-0"	16'-0" x 5'-6"	BEAM FOOTING	W8x21 2.0' x 7.4'	W10x22 2.5' x 7.5'	W12x26 2.5' x 8.9'

MODEL SO-2008 WITH 30"-HIGH AD PANEL					
DISTANCE "A" (SEE FIGURE)	TOTAL DISPLAY SIZE		DESIGN WIND VELOCITY		
			70 MPH	80 MPH	100 MPH
10'-0"	16'-0" x 8'-6"	BEAM FOOTING	W8x18 2.0' x 7.3'	W8x21 2.0' x 8.0'	W12x26 2.5' x 8.9'
12'-0"	16'-0" x 8'-6"	BEAM FOOTING	W10x22 2.5' x 7.0'	W8x24 2.5' x 7.7'	W14x30 2.5' x 9.1'
14'-0"	16'-0" x 8'-6"	BEAM FOOTING	W8x24 2.5' x 7.3'	W12x26 2.5' x 8.1'	W10x33 2.5' x 9.5'

FOOTING = DIAMETER X DEPTH

FOOTING DIMENSIONS ARE SUGGESTIONS ONLY, PROVIDED TO ASSIST WITH ESTIMATING INSTALLATION COSTS AND ARE NOT INTENDED FOR CONSTRUCTION PURPOSES.

FOOTING DIMENSIONS ARE BASED ON ASSUMED SOIL BEARING PRESSURE OF 2000 LB/FT² AND UBC WIND CODE.

ACTUAL FOOTING DEPTH AND DIAMETER FOR A PARTICULAR INSTALLATION MUST BE DETERMINED BY A QUALIFIED STRUCTURAL ENGINEER, USING DATA FROM A SOIL SAMPLE TEST AT THE SITE.

DAKTRONICS, INC. IS NOT RESPONSIBLE FOR STRUCTURES DESIGNED AND INSTALLED BY OTHERS.

THE CONCEPTS EXPRESSED AND DETAILS SHOWN ON THIS DRAWING ARE CONFIDENTIAL AND PROPRIETARY. DO NOT REPRODUCE BY ANY MEANS, INCLUDING ELECTRONICALLY WITHOUT THE EXPRESSED WRITTEN CONSENT OF DAKTRONICS, INC. COPYRIGHT 2006 DAKTRONICS, INC.

DAKTRONICS, INC. BROOKINGS, SD 57006

PROJ: OUTDOOR SCOREBOARDS
 TITLE: INSTALLATION SPECIFICATIONS, SO-2008
 DES. BY: RNEYENS DRAWN BY: DUSWH DATE: 5-17-01

REVISION 03 APPR. BY: SCALE: 1=60 1192-E07A-149074

REV.	DATE	DESCRIPTION	BY	APPR.
03	16 FEB 06	REMOVED 832-12 TNMC FROM DWG	BJC	
02	14 JUN 01	CHANGED 832-10 TNMC TO 832-12 TNMC	DUSWH	
01	06 JUN 01	ADDED TNMC CHANGED SPACING ON BEAMS FROM A MAX 10' TO A MAX 9' TO MAKE ROOM FOR TNMC	MCOP	

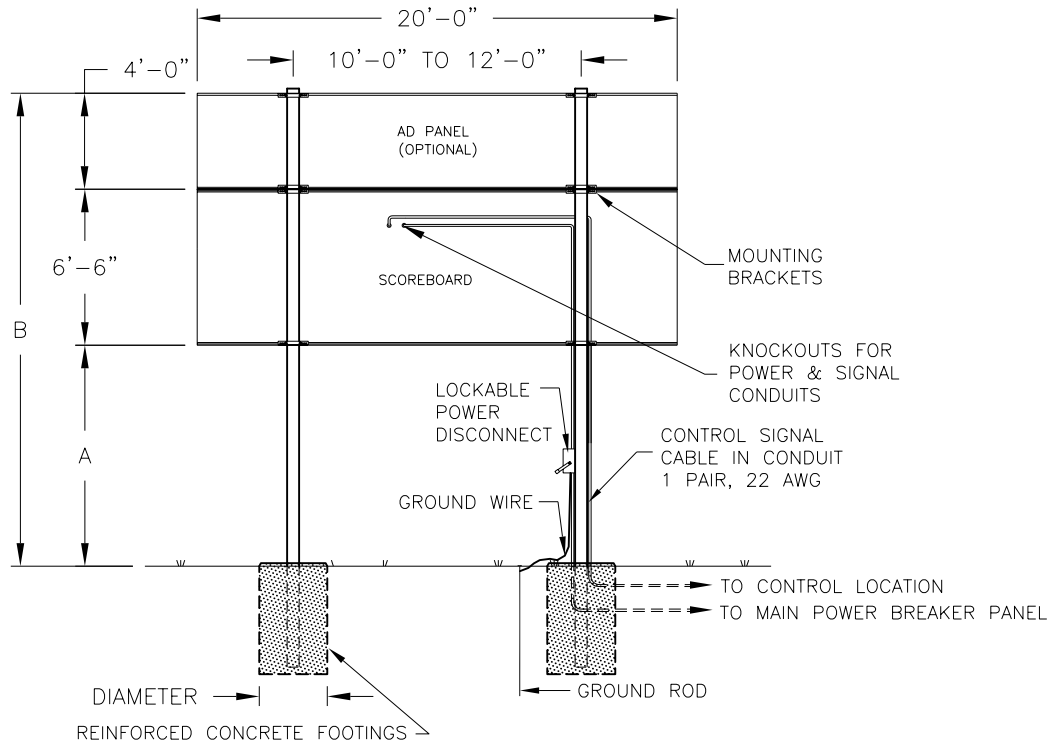

ELECTRICAL

REAR VIEW

POWER CABLE MUST HAVE A SEPERATE GROUND CONDUCTOR. SCOREBOARD MUST BE CONNECTED TO A GROUND ROD AT SCOREBOARD LOCATION.

BA-2004, BA-2005, BA-2011, & BA-2014							
VERTICAL DISTANCE (A)	AD PANEL HEIGHT	COMBINED HEIGHT (B)		DESIGN WIND VELOCITY			
				70 MPH	80 MPH	90 MPH	100 MPH
10 FT	NONE	16'-6"	BEAM	W8X18	W8X21	W10X22	W8X24
			FOOTING	2.5'x6.6'	2.5'x7.3'	2.5'x8.0'	2.5'x8.7'
	4 FT	20'-6"	BEAM	W12X26	W14X30	W10X33	W12X35
			FOOTING	2.5'x8.2'	2.5'x9.1'	2.5'x9.9'	2.5'x10.8'
12 FT	NONE	18'-6"	BEAM	W8X21	W10X22	W12X26	W12X26
			FOOTING	2.5'x7.0'	2.5'x7.7'	2.5'x8.4'	2.5'x9.1'
	4 FT	22'-6"	BEAM	W14X30	W10X33	W14X38	W12X40
			FOOTING	3.0'x8.0'	3.0'x8.8'	3.0'x9.6'	3.0'x10.4'
14 FT	NONE	20'-6"	BEAM	W10X22	W12X26	W12X26	W14X30
			FOOTING	3.0'x6.8'	3.0'x7.5'	3.0'x8.2'	3.0'x8.8'
	4 FT	24'-6"	BEAM	W10X33	W14X38	W12X40	W14X43
			FOOTING	3.0'x8.3'	3.0'x9.1'	3.0'x10.0'	3.0'x10.8'
16 FT	NONE	22'-6"	BEAM	W12X26	W14X30	W10X33	W12X35
			FOOTING	3.0'x7.1'	3.0'x7.8'	3.0'x8.5'	3.0'x9.2'
	4 FT	26'-6"	BEAM	W14X38	W12X46	W14X43	W14X48
			FOOTING	3.0'x8.6'	3.0'x9.5'	3.0'x10.4'	3.0'x11.2'
18 FT	NONE	24'-6"	BEAM	W14X30	W10X33	W12X35	W16X40
			FOOTING	3.0'x7.3'	3.0'x8.1'	3.0'x8.8'	3.0'x9.5'
	4 FT	28'-6"	BEAM	W12X40	W14X43	W14X48	W14X53
			FOOTING	3.0'x8.9'	3.0'x9.8'	3.0'x10.7'	3.0'x11.5'
20 FT	NONE	26'-6"	BEAM	W10X33	W12X35	W16X40	W12X40
			FOOTING	3.0'x7.6'	3.0'x8.4'	3.0'x9.1'	3.0'x9.9'
	4 FT	30'-6"	BEAM	W12X40	W12X48	W14X53	W14X61
			FOOTING	3.0'x9.2'	3.0'x10.1'	3.0'x11.0'	3.0'x11.9'

FOOTING = DIAMETER X DEPTH

FOOTING DIMENSIONS ARE SUGGESTIONS ONLY, PROVIDED TO ASSIST WITH ESTIMATING INSTALLATION COSTS, AND ARE NOT INTENDED FOR CONSTRUCTION PURPOSES.

COLUMNS AND FOOTINGS MUST BE DESIGNED BY A STATE LICENCED ENGINEER. DAKTRONICS DOES NOT ASSUME ANY LIABILITY FOR ANY INSTALLATIONS DERIVED FROM THIS INFORMATION OR DESIGNED AND INSTALLED BY OTHERS.

A NOTE ABOUT BEAM NOMENCLATURE:

For a typical beam, W12x30 for example, "W" stands for "Wide-Flange Beam". The first number (12) is the approximate front to rear dimension of the beam in inches. The second number (30) is the weight per foot in pounds. This numbering is standard in the steel industry. Widths vary from 8 to 14 inches in this chart.

REV.	DATE	DESCRIPTION	BY	APPR.
04	30 JUL 07	ADDED BA-2014	KDD	
03	9 NOV 05	CHANGED POLE SPACING TO 10' - 12'	JKU	
02	15JAN03	ADDED BA-2011 IN TEXT	MCOPL	
01	08AUG01	ADDED BA-2005 IN TEXT	MCOPL	

DAKTRONICS, INC. BROOKINGS, SD 57006

PROJ: **OUTDOOR INCANDESCENT SCOREBOARDS**

TITLE: **INSTALLATION SPECIFICATIONS; BA-2004/2005/2011/2014**

DES. BY: **MCOPLAN** DRAWN BY: **MCOPLAN** DATE: **23JULY01**

REVISION: **04** APPR. BY: _____ SCALE: **1=96**

1091-R10A-152777

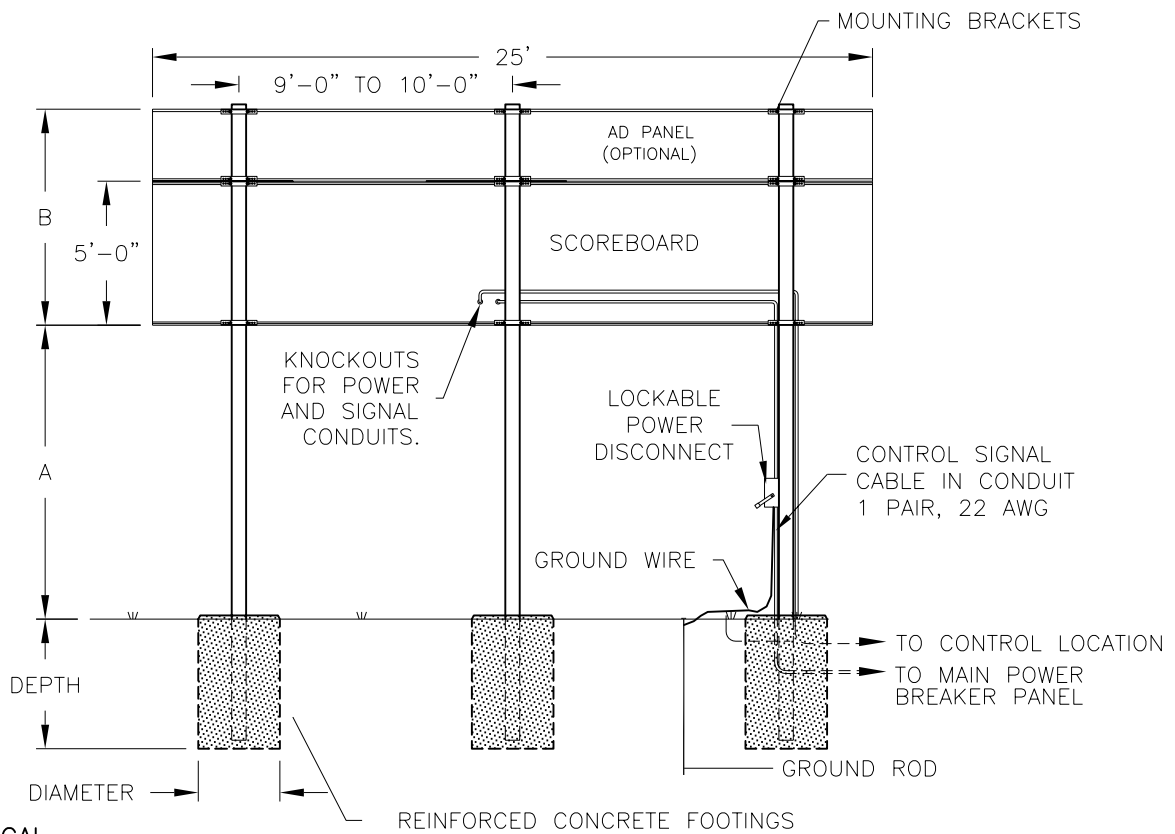

ELECTRICAL

POWER CABLE MUST HAVE A SEPERATE GROUND CONDUCTOR. SCOREBOARD MUST BE CONNECTED TO A GROUND ROD AT SCOREBOARD LOCATION.

REINFORCED CONCRETE FOOTINGS

**MS-2012
REAR VIEW**

FOOTING DIMENSIONS ARE SUGGESTIONS ONLY, PROVIDED TO ASSIST WITH ESTIMATING INSTALLATION COSTS, AND ARE NOT INTENDED FOR CONSTRUCTION PURPOSES.

COLUMNS AND FOOTINGS MUST BE DESIGNED BY A STATE LICENCED ENGINEER. DAKTRONICS DOES NOT ASSUME ANY LIABILITY FOR ANY INSTALLATIONS DERIVED FROM THIS INFORMATION OR DESIGNED AND INSTALLED BY OTHERS.

A NOTE ABOUT BEAM NOMENCLATURE:

For a typical beam, W12x30 for example, "W" stands for "Wide-Flange Beam". The first number (12) is the approximate front to rear dimension of the beam in inches. The second number (30) is the weight per foot in pounds. This numbering is standard in the steel industry. Widths vary from 4 to 8 inches in this chart.

MS-2012

VERTICAL DISTANCE (A)	AD PANEL HEIGHT	COMBINED HEIGHT (B)	DESIGN WIND VELOCITY			
			70 MPH	80 MPH	100 MPH	
10 FT	NONE	10'-0"	BEAM	W6X15	W8X18	W8X18
			FOOTING	2.0'X6.5'	2.0'X7.1'	2.8'X8.4'
	2 FT	12'-0"	BEAM	W8X18	W8X21	W12X26
			FOOTING	2.6'X7.5'	2.0'X8.2'	2.9'X9.1'
4 FT	14'-0"	BEAM	W10X22	W12X26	W14X30	
		FOOTING	2.0'X8.4'	2.5'X8.4'	2.5'X10.0'	
12 FT	NONE	10'-0"	BEAM	W8X18	W8X18	W10X22
			FOOTING	2.5'X6.3'	2.5'X6.9'	2.5'X8.2'
	2 FT	12'-0"	BEAM	W10X22	W8X24	W14X30
			FOOTING	2.5'X7.1'	2.5'X7.9'	2.5'X9.3'
4 FT	14'-0"	BEAM	W12X26	W14X30	W12X35	
		FOOTING	2.5'X8.0'	2.5'X8.8'	2.5'X10.4'	
14 FT	NONE	10'-0"	BEAM	W8X18	W10X22	W12X26
			FOOTING	2.5'X6.6'	2.5'X7.2'	2.5'X8.5'
	2 FT	12'-0"	BEAM	W8X24	W12X26	W10X33
			FOOTING	2.5'X7.5'	2.5'X8.3'	2.5'X9.8'
4 FT	14'-0"	BEAM	W10X30	W10X33	W16X40	
		FOOTING	2.5'X8.3'	2.5'X9.2'	2.5'X10.1'	

FOOTING = DIAMETER X DEPTH

DAKTRONICS, INC. BROOKINGS, SD 57006

PROJ: OUTDOOR LED SCOREBOARDS

TITLE: INSTALLATION SPECIFICATIONS; MS-2012

DES. BY: MCOPLAN

DRAWN BY: MCOPLAN

DATE: 23JULY01

REVISION

APPR. BY:

SCALE: 1=80

1192-R10A-152790

REV.	DATE	DESCRIPTION	BY	APPR.

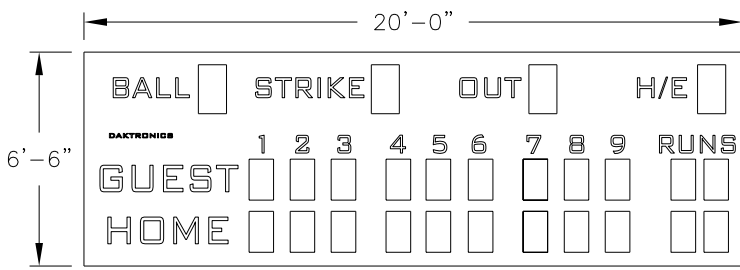

BA-2004-11

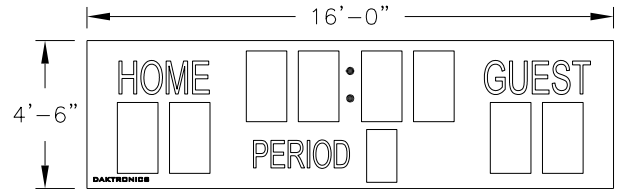

MS-2002-11

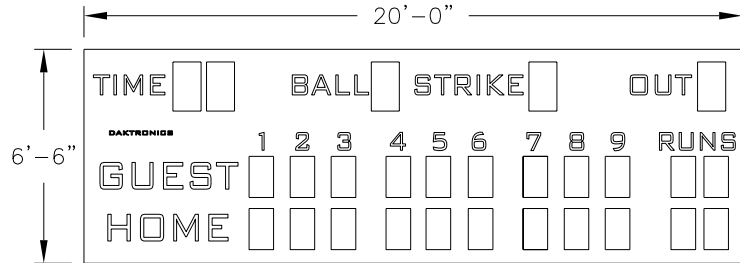

BA-2005-11

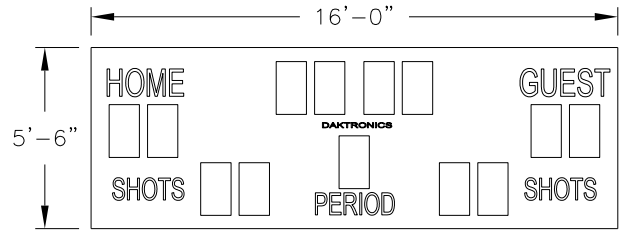

SO-2008-11

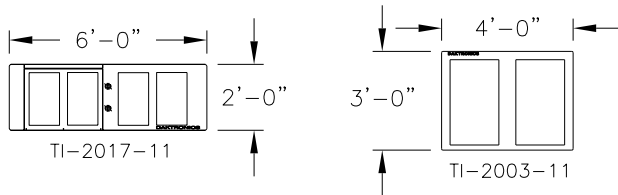

TI-2017-11

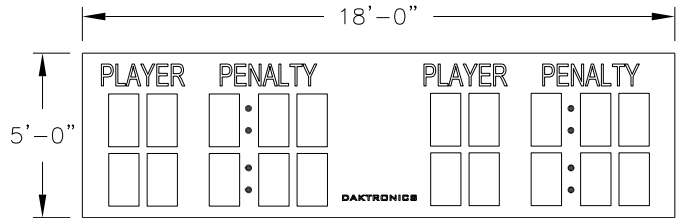

MS-2004-11

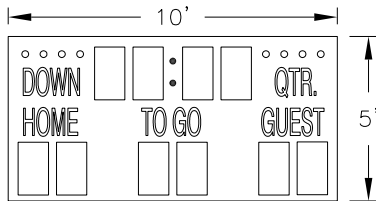

FB-2005-11

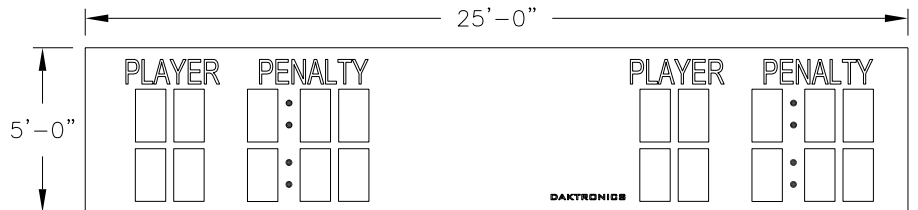

MS-2012-11

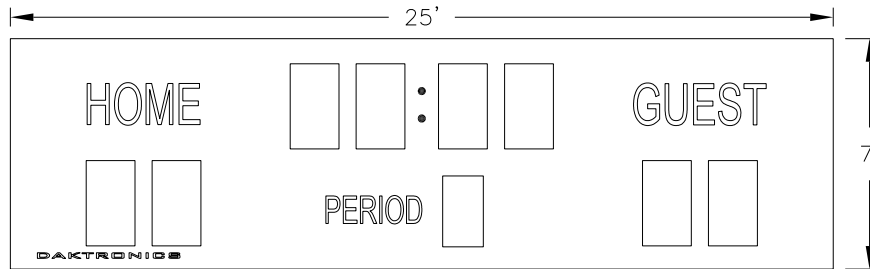

MS-2006-11

DAKTRONICS, INC. BROOKINGS, SD 57006				
PROJ: OUTDOOR LED SCOREBOARDS				
TITLE: SINGLE SECTION LED SCOREBOARD MODELS				
DES. BY: MCOPLAN		DRAWN BY: MCOPLAN		DATE: 24JULY01
REVISION	APPR. BY:	1192-E07A-152950		
REV.	SCALE: 1=70			
02	29AUG02	ADDED MODELS MS-2006-11, FB-2005-11	MCOPL	
01	08AUG01	ADDED MODEL TI-2017-11	MCOPL	
REV.	DATE	DESCRIPTION	BY	APPR.

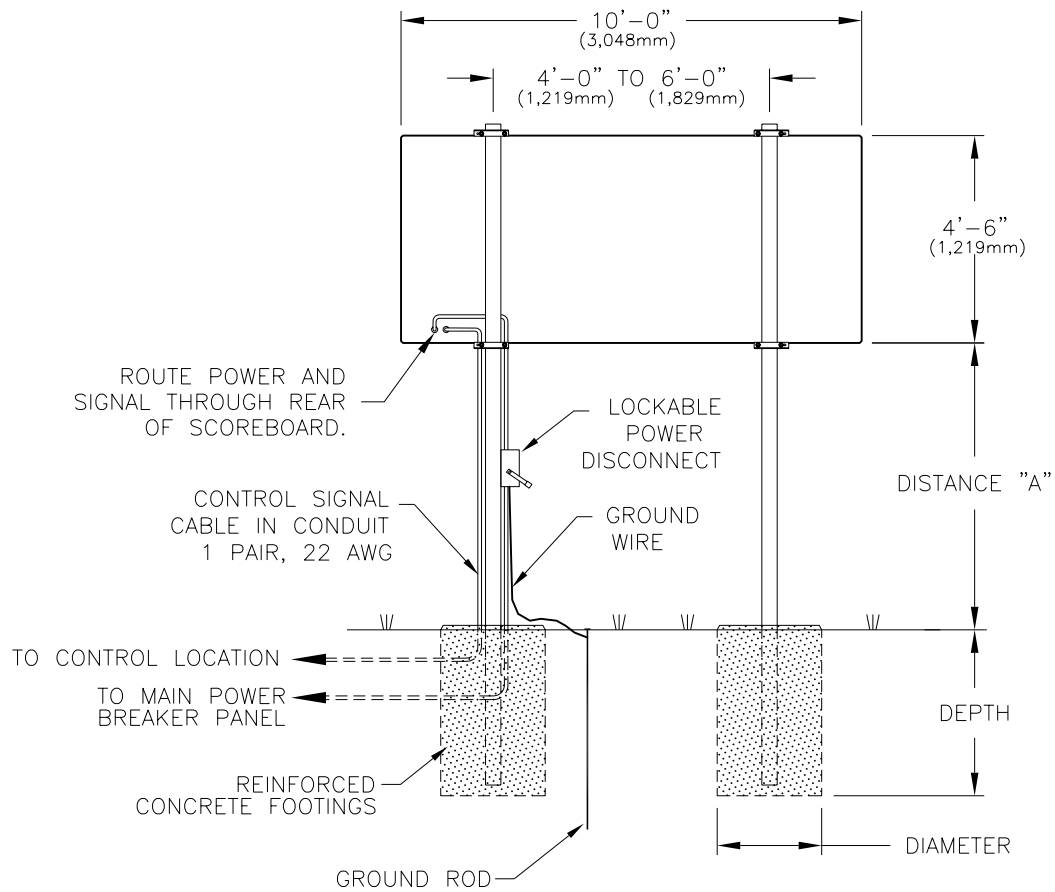

REAR VIEW

MODEL BA-2003					
DISTANCE "A" (SEE FIGURE)	TOTAL DISPLAY SIZE		DESIGN WIND VELOCITY		
			70 MPH	80 MPH	100 MPH
10'-0"	10'-0" x 4'-6"	BEAM FOOTING	W8X10 2.0' x 8.9'	W10x12 2.5' x 5.0'	W10x15 2.5' x 5.9'
12'-0"	10'-0" x 4'-6"	BEAM FOOTING	W10x15 2.5' x 5.2'	W6x15 2.5' x 5.8'	W8x18 2.5' x 6.8'
14'-0"	10'-0" x 4'-6"	BEAM FOOTING	W6x16 2.5' x 5.8'	W8x18 2.5' x 6.4'	W8x21 2.5' x 7.6'

FOOTING = DIAMETER X DEPTH

FOOTING DIMENSIONS ARE SUGGESTIONS ONLY, PROVIDED TO ASSIST WITH ESTIMATING INSTALLATION COSTS AND ARE NOT INTENDED FOR CONSTRUCTION PURPOSES.

UBC 97 CODE USED WITH SOIL CLASS 3.

ACTUAL FOOTING DEPTH AND DIAMETER FOR A PARTICULAR INSTALLATION MUST BE DETERMINED BY A QUALIFIED STRUCTURAL ENGINEER, USING DATA FROM A SOIL SAMPLE TEST AT THE SITE.

DAKTRONICS, INC. IS NOT RESPONSIBLE FOR STRUCTURES DESIGNED AND INSTALLED BY OTHERS.

DAKTRONICS, INC. BROOKINGS, SD 57006

PROJ: OUTDOOR LED DIGIT SCOREBOARDS

TITLE: INSTALLATION SPECIFICATIONS, BA-2003

DES. BY:

DRAWN BY: KBRICKER

DATE: 01 NOV 01

REVISION

APPR. BY:

01

SCALE: 1=50

1192-E10A-158322

REV.	DATE	DESCRIPTION	BY	APPR.
01	25 OCT 07	ADDED MILLIMETERS DIMENSIONS	KDD	

REV.	DATE	DESCRIPTION	BY	APPR.
02	11 SEPT 06	CHANGED CONNECTOR FROM 4 PIN TO 2 PIN ON THE HORN HARNESS	AMG	
01	22 DEC 04	REPLACED E-1084 WITH E-1044	ADH	

PROJ: OUTDOOR LED SCOREBOARDS	
TITLE: 120V AC HORN MOUNTING	
DES. BY: MCOPLAN	DRAWN BY: MCOPLAN
REVISION	APPR. BY:
02	
SCALE: 1=5	DATE: 31JAN02
1192-E10A-162100	

DAKTRONICS, INC. BROOKINGS, SD 57006

120V HORN MOUNTING FOR BOTTOM EXTRUSION

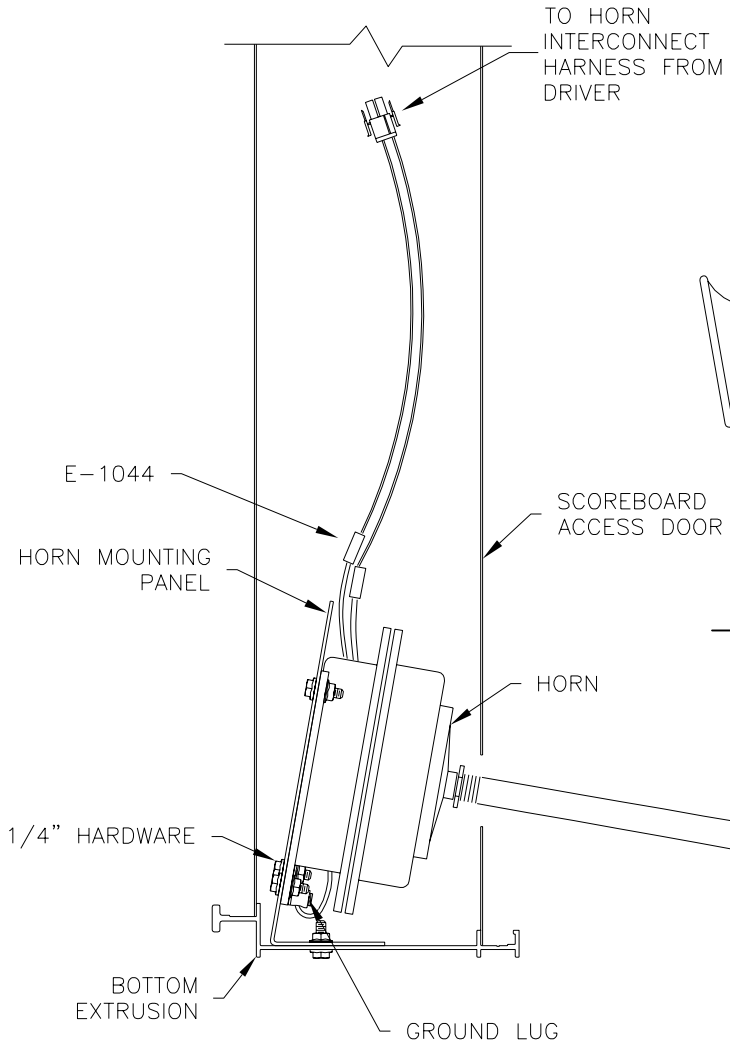

NOTE:
HORN IS TO BE MOUNTED BEHIND ACCESS DOOR THAT HAS 2" DIAMETER KNOCKOUT.

120V HORN MOUNTING FOR UPPER EXTRUSION

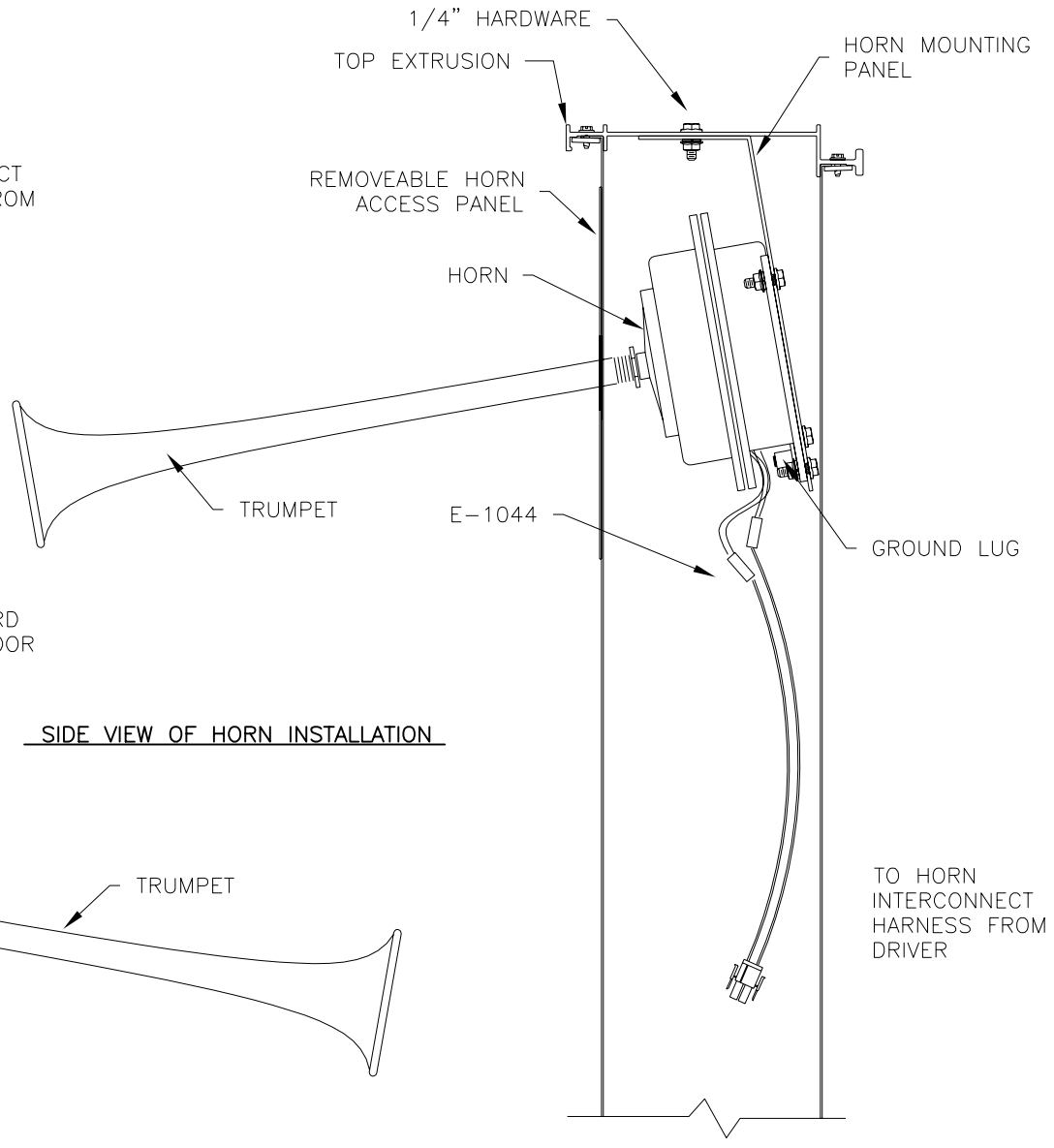

NOTE:
HORN IS TO BE MOUNTED BEHIND THE REMOVEABLE HORN ACCESS PANEL.

SIDE VIEW OF HORN INSTALLATION

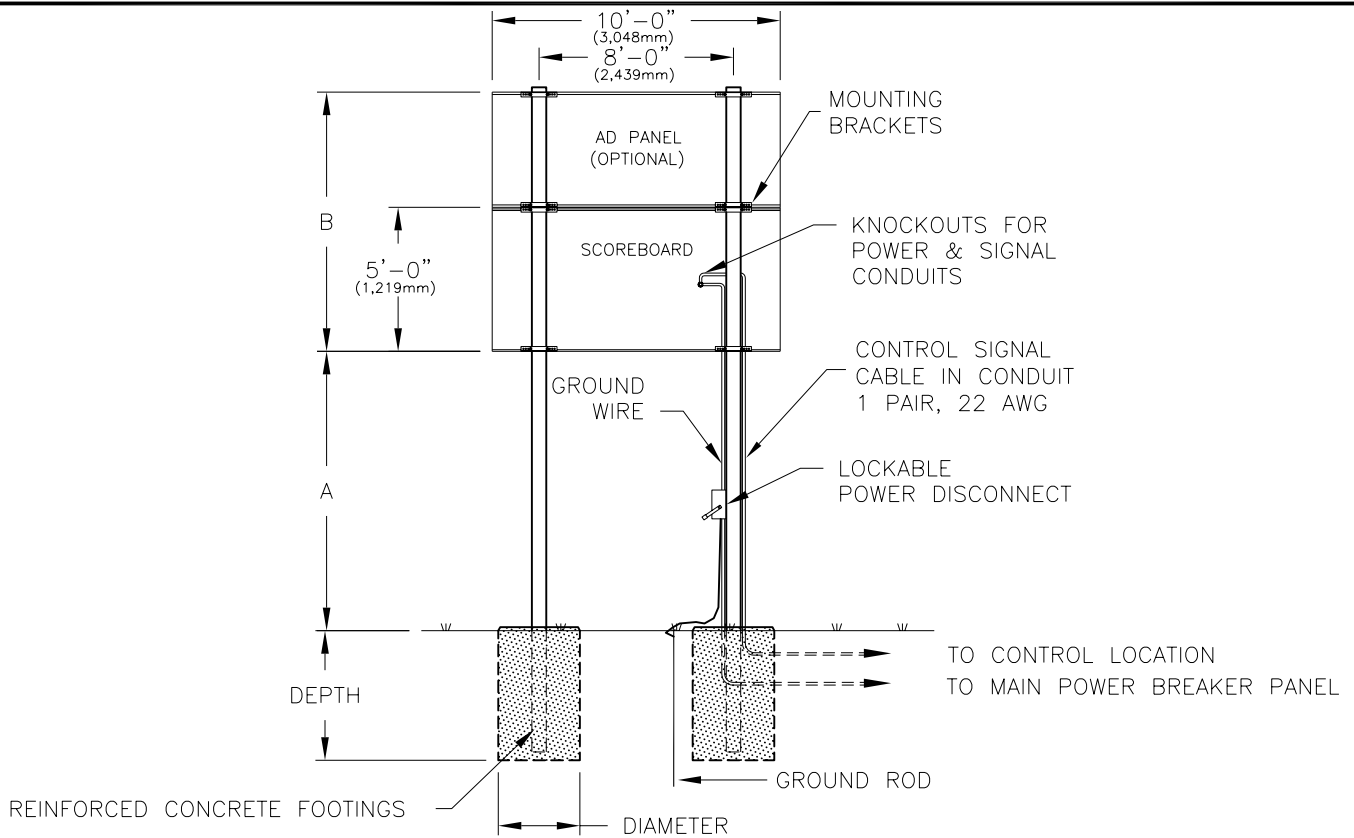

REAR VIEW
FB-2005-11

ELECTRICAL

POWER CABLE MUST HAVE A SEPARATE GROUND CONDUCTOR. SCOREBOARD MUST BE CONNECTED TO A GROUND ROD AT SCOREBOARD LOCATION.

FOOTING DIMENSIONS ARE SUGGESTIONS ONLY, PROVIDED TO ASSIST WITH ESTIMATING INSTALLATION COSTS, AND ARE NOT INTENDED FOR CONSTRUCTION PURPOSES.

COLUMNS AND FOOTINGS MUST BE DESIGNED BY A STATE LICENCED ENGINEER. DAKTRONICS DOES NOT ASSUME ANY LIABILITY FOR ANY INSTALLATIONS DERIVED FROM THIS INFORMATION OR DESIGNED AND INSTALLED BY OTHERS.

MODEL FB-2005-11						
VERTICAL DISTANCE (A)	AD PANEL HEIGHT	COMBINED HEIGHT (B)		DESIGN WIND VELOCITY		
				70 MPH	80 MPH	100 MPH
10 FT	NONE	5'-0"	BEAM	W10x12	W10x15	W6x15
			FOOTING	2.5 x 4.7	2.5 x 5.2	2.5 x 6.1
	4 FT	9'-0"	BEAM	W8x16	W8x21	W8x24
			FOOTING	2.5 x 6.0	2.5 x 6.6	2.5 x 7.8
12 FT	NONE	5'-0"	BEAM	W10x15	W6x15	W8x18
			FOOTING	2.5 x 5.0	2.5 x 5.5	2.5 x 6.5
	4 FT	9'-0"	BEAM	W10x22	W10x22	W12x26
			FOOTING	2.5 x 6.3	2.5 x 6.9	2.5 x 8.1
14 FT	NONE	5'-0"	BEAM	W6x15	W8x18	W10x22
			FOOTING	2.5 x 5.3	2.5 x 5.8	2.5 x 6.8
	4 FT	9'-0"	BEAM	W8x24	W8x24	W14x30
			FOOTING	2.5 x 6.6	2.5 x 7.2	2.5 x 8.5

FOOTING = DIAMETER X DEPTH

A NOTE ABOUT BEAM NOMENCLATURE:

For a typical beam, W12x30 for example, "W" stands for "Wide-Flange Beam". The first number (12) is the approximate front to rear dimension of the beam in inches. The second number (30) is the weight per foot in pounds. This numbering is standard in the steel industry. Widths vary from 4 to 8 inches in this chart.

REV.	DATE	DESCRIPTION	BY	APPR.
02	25 OCT 07	ADDED MILLIMETERS DIMENSIONS	KDD	
1	05 MAR 03	CHANGED DWG NUMBER FROM A-162889 TO A-162886 IN THE TITLE BLOCK.	TWEBER	

DAKTRONICS, INC. BROOKINGS, SD 57006			
PROJ: OUTDOOR LED DIGIT SCOREBOARDS			
TITLE: INSTALLATION SPECIFICATIONS, FB-2005-11			
DES. BY:	DRAWN BY: KBRICKER	DATE: 15FEB02	
REVISION	APPR. BY:	1192-E10A-162886	
02	SCALE: 1=80		

LANDLINE MODEM
OP-1279-0003
COATED MODEM
(INSTALL OPTION)

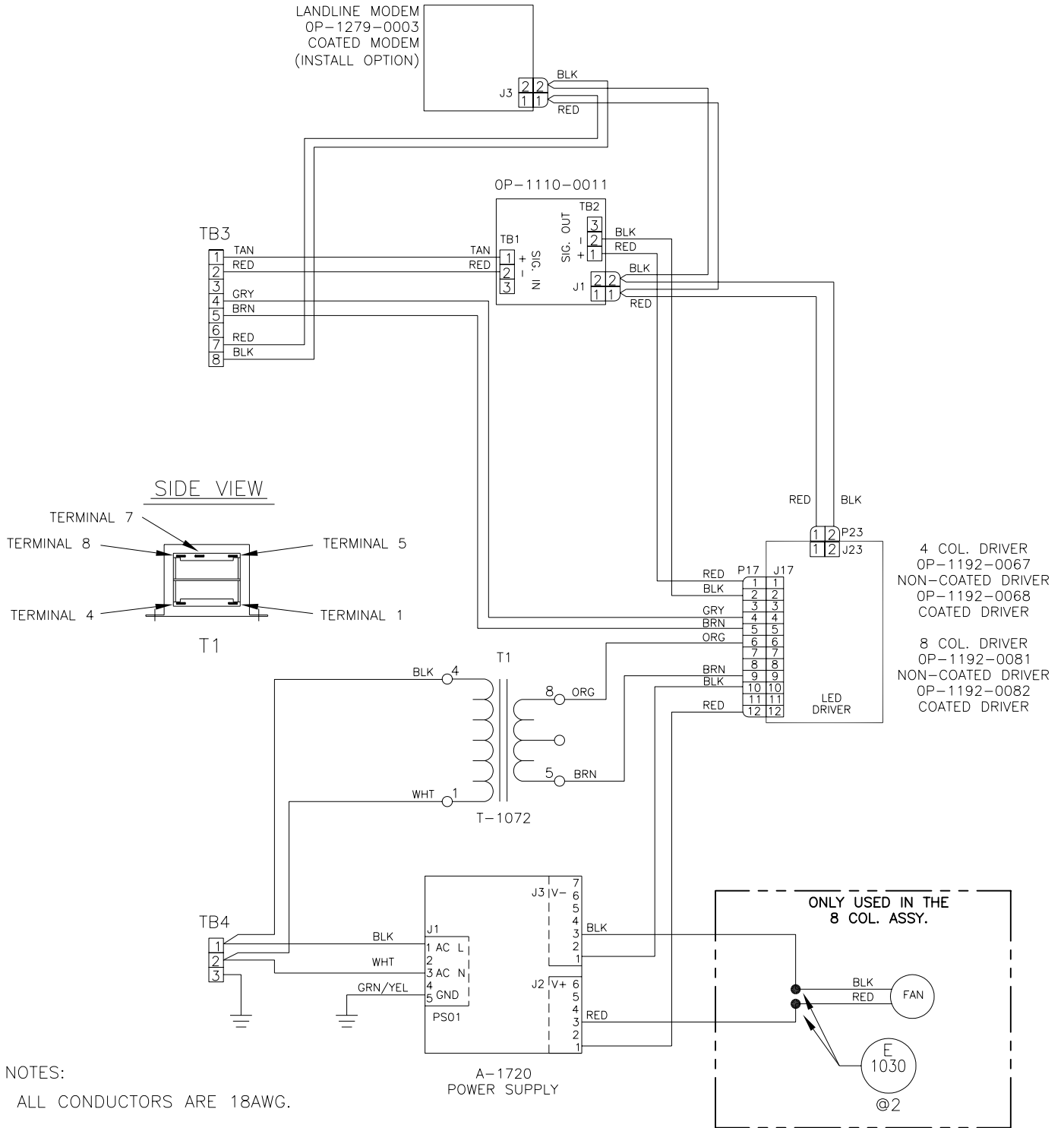

4 COL. DRIVER
OP-1192-0067
NON-COATED DRIVER
OP-1192-0068
COATED DRIVER

8 COL. DRIVER
OP-1192-0081
NON-COATED DRIVER
OP-1192-0082
COATED DRIVER

NOTES:
ALL CONDUCTORS ARE 18AWG.

A-1720
POWER SUPPLY

08	17 DEC 03	CHANGED WIRE COLORS OF T1 CONNECTIONS. ADDED SIDE VIEW OF T1.	JBS	
07	29 APR 03	ADDED T1, FOR TIMING.	TAS	MWM
06	24 FEB 03	CHANGED J3 ON POWER SUPPLY TO 7 PINS PER ECO-27985.	AVB	
05	14 JAN 03	CHANGED THE BLU TEXT TO RED ON TB3 CONNECTOR	CME	
04	24 OCT 02	CHANGED 12V DC WIRING CONNECTIONS FROM MASC DRIVER TO SIGNAL SURGE PROTECTOR, LANDLINE MODEM AND TERMINAL BLOCK	JBS	
03	29MAY02	MOVED WIRES GOING INTO PIN 6 & 9 OF P17 TO PIN 10 & 12 OF P17	NMB	
02	06 MAY 02	CHANGED WIRE COLORS FOR TB3 CONNECTIONS	MWM	
01	24APR02	ADDED TB3-7 & 8 CONNECTIONS TO 4 COL. LED DRIVER. ADDED P22 AND J22 ALSO.	THS	
REV.	DATE	DESCRIPTION	BY	APPR.

0A-1279-0086
MULTI PURPOSE HARNESS ASSY.

THE CONCEPTS EXPRESSED AND DETAILS SHOWN ON THIS DRAWING ARE CONFIDENTIAL AND PROPRIETARY. DO NOT REPRODUCE BY ANY MEANS, INCLUDING ELECTRONICALLY WITHOUT THE EXPRESSED WRITTEN CONSENT OF DAKTRONICS, INC. COPYRIGHT 2002 DAKTRONICS, INC.

DAKTRONICS, INC. BROOKINGS, SD 57006

PROJ: DATA TIME LED DISPLAYS

TITLE: SCHEMATIC; MULTIPURPOSE LED DRVR

DES. BY: MMILLER

DRAWN BY: MMILLER

DATE: 08 APR 02

REVISION

APPR. BY:

08

SCALE: 1=1

1279-R03A-165028

OP-1192-0067 UNCOATED OR OP-1192-0068 COATED
4 COLUMN MASC LED DRIVER

J-27 RS232 COM	
PIN	FUNCTION
1	RX-P
2	TX-P
3	GND-N
4	+12V -P
5	DCD-P
6	RESET-P

J19 ADDRESS	
PIN	FUNCTION
1	GND-N
2	ADD0-N
3	ADD1-N
4	GND-N
5	ADD2-N
6	ADD3-N
7	GND-N
8	ADD4-N
9	ADD5-N
10	GND-N
11	ADD6-N
12	ADD7-N

TB1 CAN	
PIN	FUNCTION
1	N/C
2	+5V-P
3	CANH-P
4	CANL-P
5	GND-N
6	GND-N

J24	
PIN	FUNCTION
1	MODEM_RTS-P
2	MODEM_RESET-P
3	MODEM_TX-P
4	GND-N
5	MODEM_RX-P
6	MODEM_DCD-P

J23 +12VDC	
PIN	FUNCTION
1	+12VDC-P
2	GND-N

J25			
FUNCTION	PIN	PIN	FUNCTION
L1_ID0-P	1	20	RED1-P
L1_ID1-P	2	19	GRN1-P
GND-N	3	18	L1_LATCH-P
GND-N	4	17	L1_DIM-P
GND-N	5	16	RED2-P
GRN2-P	6	15	RED3-P
GND-N	7	14	L1_CLK-P
GND-N	8	13	GRN3-P
L1_ID2-P	9	12	RED4-P
L1_ID3-P	10	11	GRN4-P

J26			
FUNCTION	PIN	PIN	FUNCTION
L2_ID0-P	1	20	RED1-P
L2_ID1-P	2	19	GRN1-P
GND-N	3	18	L2_LATCH-P
GND-N	4	17	L2_DIM-P
GND-N	5	16	RED2-P
GRN2-P	6	15	RED3-P
GND-N	7	14	L2_CLK-P
GND-N	8	13	GRN3-P
L2_ID2-P	9	12	RED4-P
L2_ID3-P	10	11	GRN4-P

J17 MAIN	
PIN	FUNCTION
1	CLIN-P
2	CLIN-N
3	232IN-P
4	CLOUT-P
5	CLOUT-N
6	16VAC-P
7	GND-N
8	N/C
9	16VAC-N
10	GND-N
11	N/C
12	+VBB-P

J18 RELAY	
PIN	FUNCTION
1	HORNOUT-N
2	AUXOUT2-N
3	120SW1-N
4	120SW1-P

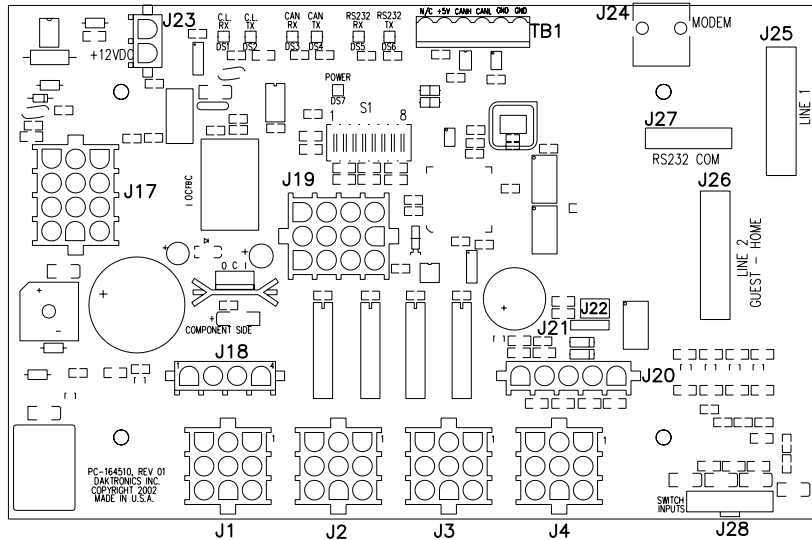

J1-4 DIGIT	
PIN	FUNCTION
1	SEGC-N
2	SEGB-N
3	SEGA-N
4	SEGF-N
5	SEGE-N
6	SEGD-N
7	+VBB-P
8	SEGH-N
9	SEGG-N

J20 PROTOCOL	
PIN	FUNCTION
1	GND
2	PR0-N
3	PR1-N
4	PR2-N
5	PR3-N

J21 ISP	
PIN	FUNCTION
1	VFP-P
2	BKD-P
3	GND-N
4	RESET-P

J28 SWITCH	
PIN	FUNCTION
1	SWITCH1-P
2	SWITCH1-N
3	SWITCH2-P
4	SWITCH2-N
5	SWITCH3-P
6	SWITCH3-N
7	SWITCH4-P
8	SWITCH4-N

J22 ISP	
PIN	FUNCTION
1	BKD-P
2	GND-N
3	N/C
4	RESET-P
5	VFP-P
6	+5V-P

NOTE:

- RED LED CL RX WILL BE ON OR BLINKING WHEN THE DRIVER IS RECEIVING SIGNAL AND OFF WHEN THERE IS NO SIGNAL WITH CL
- GREEN LED CL TX WILL BE ON OR BLINKING WHEN THE DRIVER IS RECEIVING SIGNAL AND OFF WHEN THERE IS NO SIGNAL WITH CL
- RED LED CAN RX WILL BE BLINKING WHEN THE DRIVER IS RECEIVING SIGNAL AND ON WHEN THERE IS NO SIGNAL WITH CAN
- GREEN LED CAN TX WILL BE BLINKING WHEN THE DRIVER IS RECEIVING SIGNAL AND ON WHEN THERE IS NO SIGNAL WITH CAN
- IF THERE IS NOT A CAN DEVICE CONNECTED TO TB1, CAN RX AND TX LEDS WILL BE ON AND STEADY.
- RED LED RS232 RX WILL BE ON OR BLINKING WHEN THE DRIVER IS RECEIVING SIGNAL AND OFF WHEN THERE IS NO SIGNAL WITH RS232
- GREEN LED RS232 TX6 WILL BE ON OR BLINKING WHEN THE DRIVER IS RECEIVING SIGNAL AND OFF WHEN THERE IS NO SIGNAL WITH RS232
- GREEN LED POWER INDICATES THE DRIVER HAS POWER

REV.	DATE	DESCRIPTION	BY	APPR.
3	27 NOV 04	UPDATE DRIVER J-27 FOR CORRECT PIN OUT	DMD	
2	16 MAY 03	UPDATE DRIVER FOR LATEST REVISION OF MASC DRIVER.	CJB	
1	06JUN02	ADDED LED LABELS ADDED NEW NOTES	JJS	

DAKTRONICS, INC. BROOKINGS, SD 57006			
PROJ: OUTDOOR LED SCOREBOARDS			
TITLE: 4 COLUMN MASC LED DRIVER SPECIFICATIONS			
DES. BY:	DRAWN BY: JSPAHR	DATE: 29 APR 02	
REVISION	APPR. BY:	1192-R07A-166216	
03	SCALE: 1=2		

**** NOTE ****

1. ALL ELECTRICAL INSTALLATIONS MUST MEET LOCAL AND NATIONAL ELECTRICAL CODES. INSTALLATION MUST BE PERFORMED BY QUALIFIED PERSONNEL
2. BE SURE TO CHARGE BATTERIES IN POWER PACK COMPLETELY BEFORE FIRST USE.
3. CHARGE BATTERY COMPLETELY AFTER EACH USE
4. POWER PACK INTENDED FOR TEMPORARY POWER FOR SCOREBOARDS, DO NOT LEAVE OUTSIDE, STORE IN A COOL, DRY AREA.

REAR VIEW

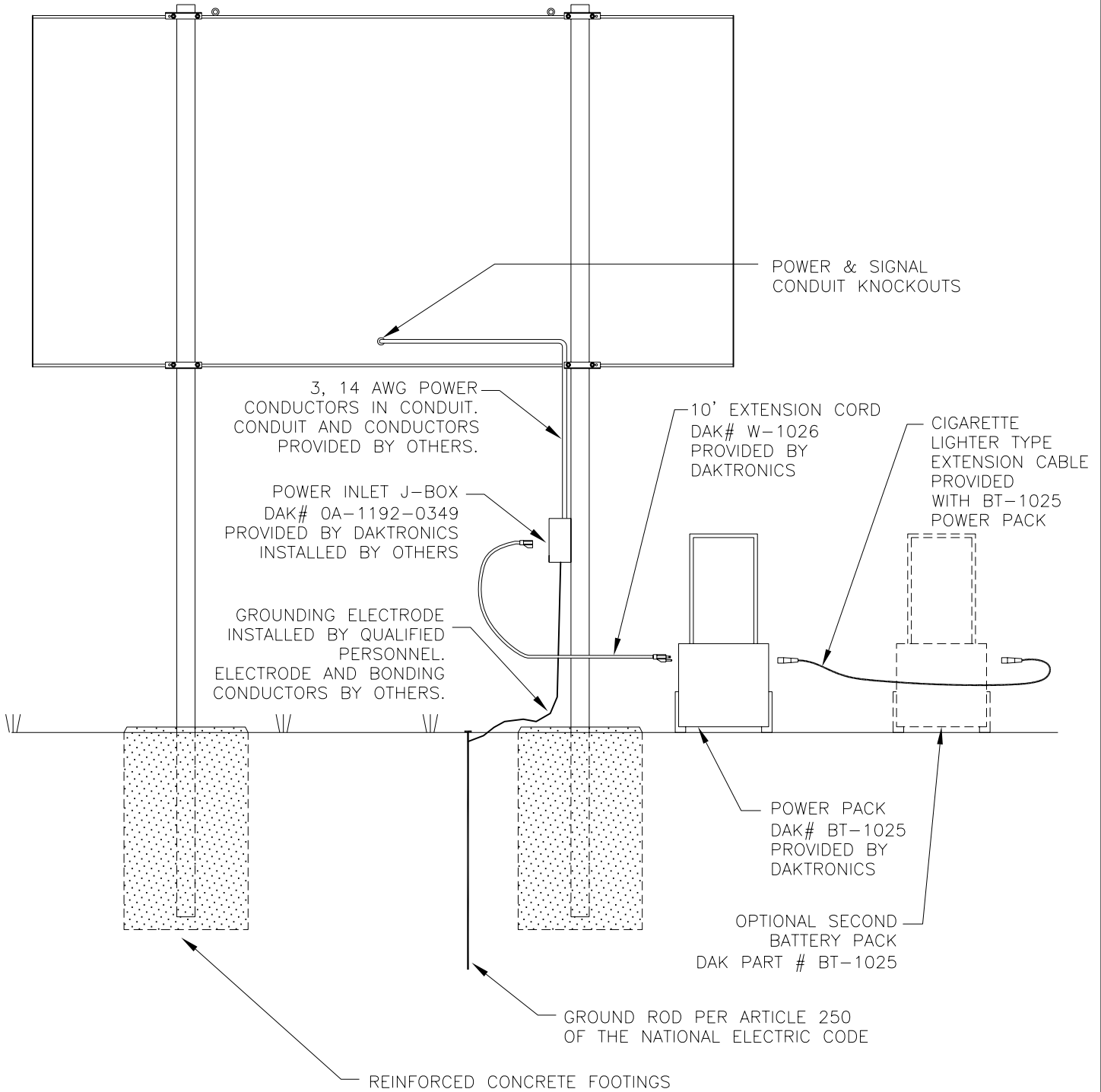

THE CONCEPTS EXPRESSED AND DETAILS SHOWN ON THIS DRAWING ARE CONFIDENTIAL AND PROPRIETARY. DO NOT REPRODUCE BY ANY MEANS, INCLUDING ELECTRONICALLY WITHOUT THE EXPRESSED WRITTEN CONSENT OF DAKTRONICS, INC. COPYRIGHT 2002 DAKTRONICS, INC.			
DAKTRONICS, INC. BROOKINGS, SD 57006			
PROJ: OUTDOOR LED SCOREBOARDS			
TITLE: INSTALLATION, PORTABLE POWERED SCOREBOARDS			
DES. BY: EBRAVEK		DRAWN BY: EBRAVEK	
		DATE: 4 JUNE 02	
REVISION	APPR. BY:	1192-E07A-166787	
00	SCALE: 1=40		

REV.	DATE	DESCRIPTION	BY	APPR.

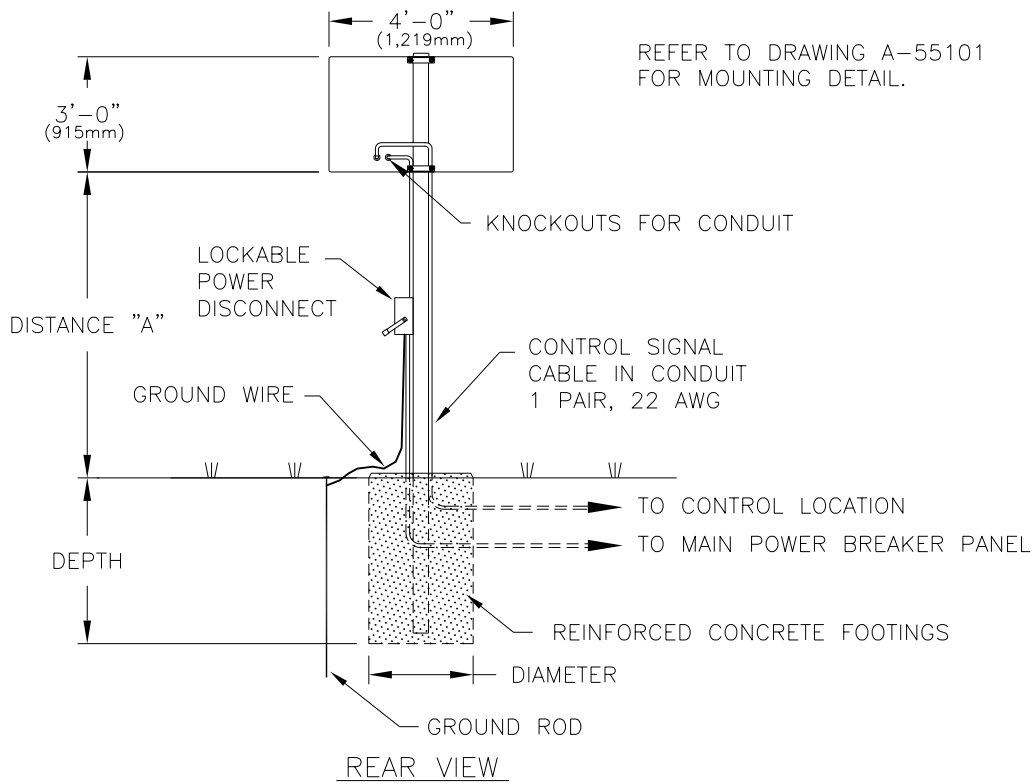

MODEL TI-2003					
DISTANCE "A" (SEE FIGURE)	TOTAL DISPLAY SIZE		DESIGN WIND VELOCITY		
			70 MPH	80 MPH	100 MPH
10'-0"	4'-0" x 3'-0"	BEAM FOOTING	TS4x4x3/16 2.0' x 3.6'	TS4x4x3/16 2.0' x 3.9'	TS4x4x3/16 2.0' x 4.6'
12'-0"	4'-0" x 3'-0"	BEAM FOOTING	TS4x4x3/16 2.0' x 3.8'	TS4x4x3/16 2.0' x 4.2'	TS4x4x3/16 2.0' x 4.9'
14'-0"	4'-0" x 3'-0"	BEAM FOOTING	TS4x4x3/16 2.0' x 4.0'	TS4x4x3/16 2.0' x 4.4'	TS4x4x3/16 2.0' x 5.2'

FOOTING = DIAMETER X DEPTH

FOOTING DIMENSIONS ARE SUGGESTIONS ONLY, PROVIDED TO ASSIST WITH ESTIMATING INSTALLATION COSTS AND ARE NOT INTENDED FOR CONSTRUCTION PURPOSES.

FOOTING DIMENSIONS ARE BASED ON ASSUMED SOIL BEARING PRESSURE OF 2000 LB/FT²

ACTUAL FOOTING DEPTH AND DIAMETER FOR A PARTICULAR INSTALLATION MUST BE DETERMINED BY A QUALIFIED STRUCTURAL ENGINEER, USING DATA FROM A SOIL SAMPLE TEST AT THE SITE.

DAKTRONICS, INC. IS NOT RESPONSIBLE FOR STRUCTURES DESIGNED AND INSTALLED BY OTHERS.

THE CONCEPTS EXPRESSED AND DETAILS SHOWN ON THIS DRAWING ARE CONFIDENTIAL AND PROPRIETARY. DO NOT REPRODUCE BY ANY MEANS, INCLUDING ELECTRONICALLY WITHOUT THE EXPRESSED WRITTEN CONSENT OF DAKTRONICS, INC. COPYRIGHT 2002 DAKTRONICS, INC.

DAKTRONICS, INC. BROOKINGS, SD 57006

PROJ: OUTDOOR SCOREBOARDS

TITLE: INSTALLATION SPECIFICATIONS; TI-2003

DES. BY: MCOPLAN

DRAWN BY: MCOPLAN

DATE: 18JUN02

REVISION

APPR. BY:

01

SCALE: 1=50

1091-E10A-169367

REV.	DATE	DESCRIPTION	BY	APPR.
01	25 OCT 07	ADDED MILLIMETERS DIMENSIONS	KDD	

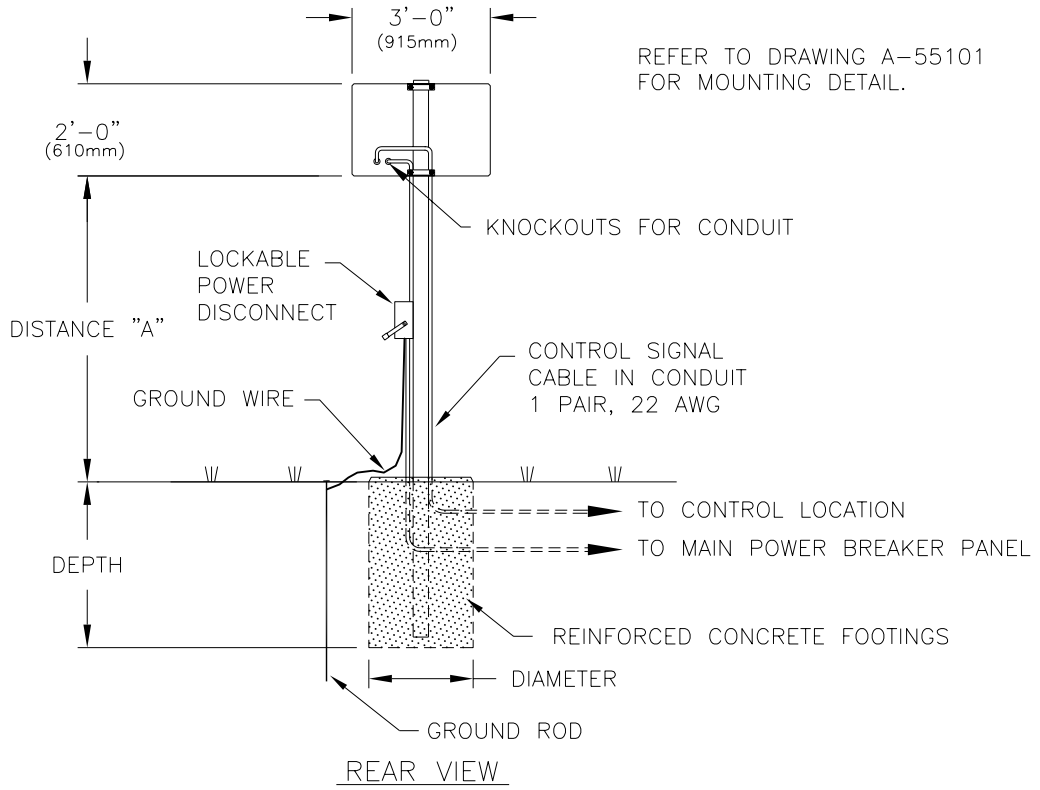

MODEL TI-218					
DISTANCE "A" (SEE FIGURE)	TOTAL DISPLAY SIZE		DESIGN WIND VELOCITY		
			70 MPH	80 MPH	100 MPH
10'-0"	2'-0" x 3'-0"	BEAM FOOTING	TS4x4x3/16 2.0' x 2.9'	TS4x4x3/16 2.0' x 3.2'	TS4x4x3/16 2.0' x 3.7'
12'-0"	2'-0" x 3'-0"	BEAM FOOTING	TS4x4x3/16 2.0' x 3.1'	TS6x4x3/16 2.0' x 3.4'	TS6x4x3/16 2.0' x 4.0'
14'-0"	2'-0" x 3'-0"	BEAM FOOTING	TS6x4x3/16 2.0' x 3.3'	TS6x4x3/16 2.0' x 3.7'	TS6x4x3/16 2.0' x 4.3'

FOOTING = DIAMETER X DEPTH

FOOTING DIMENSIONS ARE SUGGESTIONS ONLY, PROVIDED TO ASSIST WITH ESTIMATING INSTALLATION COSTS AND ARE NOT INTENDED FOR CONSTRUCTION PURPOSES.

FOOTING DIMENSIONS ARE BASED ON ASSUMED SOIL BEARING PRESSURE OF 2000 LB/FT²

ACTUAL FOOTING DEPTH AND DIAMETER FOR A PARTICULAR INSTALLATION MUST BE DETERMINED BY A QUALIFIED STRUCTURAL ENGINEER, USING DATA FROM A SOIL SAMPLE TEST AT THE SITE.

DAKTRONICS, INC. IS NOT RESPONSIBLE FOR STRUCTURES DESIGNED AND INSTALLED BY OTHERS.

THE CONCEPTS EXPRESSED AND DETAILS SHOWN ON THIS DRAWING ARE CONFIDENTIAL AND PROPRIETARY. DO NOT REPRODUCE BY ANY MEANS, INCLUDING ELECTRONICALLY WITHOUT THE EXPRESSED WRITTEN CONSENT OF DAKTRONICS, INC. COPYRIGHT 2002 DAKTRONICS, INC.

DAKTRONICS, INC. BROOKINGS, SD 57006

PROJ: OUTDOOR SCOREBOARDS

TITLE: INSTALLATION SPECIFICATIONS; TI-218

DES. BY: MCOPLAN

DRAWN BY: MCOPLAN

DATE: 18JUN02

REV.	DATE	DESCRIPTION	BY	APPR.
01	25 OCT 07	ADDED MILLIMETERS DIMENSIONS	KDD	

REVISION	APPR. BY:
01	SCALE: 1=50

1091-E10A-169376

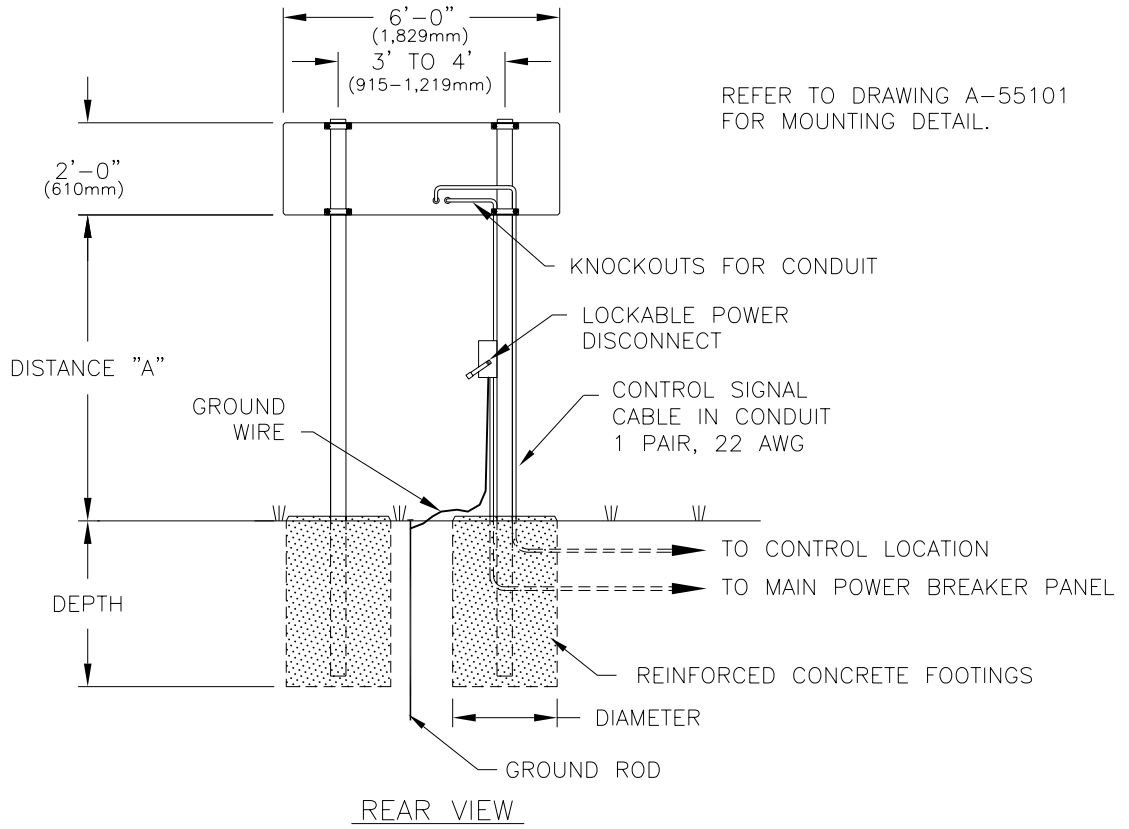

MODEL TI-418, RO-2011, CT-2001, TI-2019					
DISTANCE "A" (SEE FIGURE)	TOTAL DISPLAY SIZE		DESIGN WIND VELOCITY		
			70 MPH	80 MPH	100 MPH
10'-0"	2'-0" x 6'-0"	BEAM FOOTING	W10X8 2.0 X 2.9	W10X8 2.0 X 3.2	W10X9 2.0 X 3.7
12'-0"	2'-0" x 6'-0"	BEAM FOOTING	W10X9 2.0 X 3.1	W6X9 2.0 X 3.4	W6X9 2.0 X 4.0
14'-0"	2'-0" x 6'-0"	BEAM FOOTING	W6X9 2.0 X 3.3	W6X9 2.0 X 3.7	W10X12 2.0 X 4.3

FOOTING = DIAMETER X DEPTH

FOOTING DIMENSIONS ARE SUGGESTIONS ONLY, PROVIDED TO ASSIST WITH ESTIMATING INSTALLATION COSTS AND ARE NOT INTENDED FOR CONSTRUCTION PURPOSES.

FOOTING DIMENSIONS ARE BASED ON ASSUMED SOIL BEARING PRESSURE OF 2000 LB/FT²

ACTUAL FOOTING DEPTH AND DIAMETER FOR A PARTICULAR INSTALLATION MUST BE DETERMINED BY A QUALIFIED STRUCTURAL ENGINEER, USING DATA FROM A SOIL SAMPLE TEST AT THE SITE.

DAKTRONICS, INC. IS NOT RESPONSIBLE FOR STRUCTURES DESIGNED AND INSTALLED BY OTHERS.

THE CONCEPTS EXPRESSED AND DETAILS SHOWN ON THIS DRAWING ARE CONFIDENTIAL AND PROPRIETARY. DO NOT REPRODUCE BY ANY MEANS, INCLUDING ELECTRONICALLY WITHOUT THE EXPRESSED WRITTEN CONSENT OF DAKTRONICS, INC. COPYRIGHT 2002 DAKTRONICS, INC.

REV.	DATE	DESCRIPTION	BY	APPR.
03	25 OCT 07	ADDED MILLIMETERS DIMENSIONS	KDD	
02	22MAY03	ADDED MODEL CT-2001	MCOPL	
1	14 FEB 03	ADDED MODEL RO-2011 AND TI-2019.	TWEBER	

DAKTRONICS, INC. BROOKINGS, SD 57006	
PROJ: OUTDOOR SCOREBOARDS	
TITLE: INSTALLATION SPECS; TI-418/RO-2011/CT-2001/TI-2019	
DES. BY: MCOPLAN	DRAWN BY: MCOPLAN
DATE: 18JUN02	
REVISION	APPR. BY:
03	SCALE: 1=50
1091-E10A-169380	

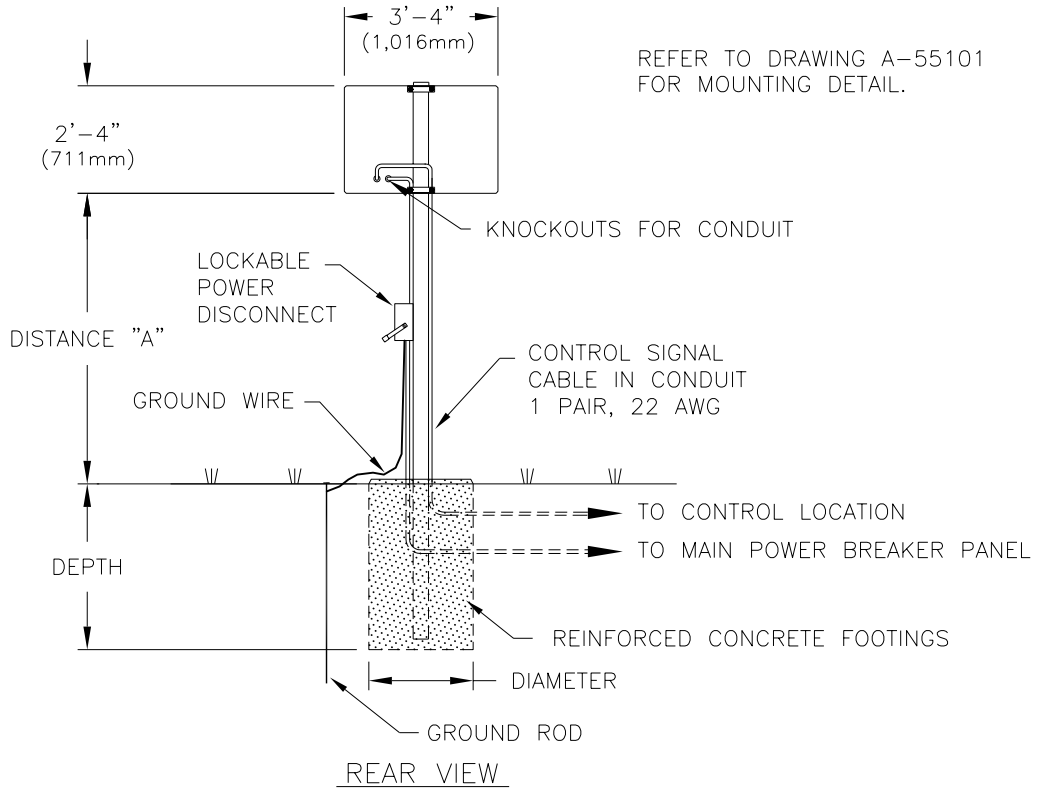

MODEL TI-2015					
DISTANCE "A" (SEE FIGURE)	TOTAL DISPLAY SIZE		DESIGN WIND VELOCITY		
			70 MPH	80 MPH	100 MPH
10'-0"	12'-4" x 3'-4"	BEAM FOOTING	TS4x4x3/16 2.0' x 4.0'	TS4x4x3/16 2.0' x 4.0'	TS4x4x3/16 2.0' x 4.5'
12'-0"	14'-4" x 3'-4"	BEAM FOOTING	TS4x4x3/16 2.0' x 4.0'	TS4x4x3/16 2.0' x 4.1'	TS4x4x3/16 2.0' x 4.8'
14'-0"	16'-4" x 3'-4"	BEAM FOOTING	TS4x4x3/16 2.0' x 4.0'	TS4x4x3/16 2.0' x 4.4'	TS4x4x3/16 2.0' x 5.2'

FOOTING = DIAMETER X DEPTH

DESIGN BASED ON UBC 97 BUILDING CODE.
BEAM IS ASSUMED TO BE A500-B STEEL (46ksi).

FOOTING DIMENSIONS ARE SUGGESTIONS ONLY, PROVIDED
TO ASSIST WITH ESTIMATING INSTALLATION COSTS AND
ARE NOT INTENDED FOR CONSTRUCTION PURPOSES.

FOOTING DIMENSIONS ARE BASED ON ASSUMED
UBC SOIL CLASS 4 (LATERAL BEARING 150psf/ft x 2)

ACTUAL FOOTING DEPTH AND DIAMETER FOR A PARTICULAR
INSTALLATION MUST BE DETERMINED BY A QUALIFIED
STRUCTURAL ENGINEER, USING DATA FROM A SOIL SAMPLE
TEST AT THE SITE.

DAKTRONICS, INC. IS NOT RESPONSIBLE FOR STRUCTURES
DESIGNED AND INSTALLED BY OTHERS.

WIND DESIGN:
EXPOSURE C
I = 1.0
C_q = 1.4

THE CONCEPTS EXPRESSED AND DETAILS SHOWN ON THIS DRAWING ARE CONFIDENTIAL AND PROPRIETARY. DO NOT REPRODUCE BY ANY MEANS, INCLUDING ELECTRONICALLY WITHOUT THE EXPRESSED WRITTEN CONSENT OF DAKTRONICS, INC. COPYRIGHT 2003 DAKTRONICS, INC.

DAKTRONICS, INC. BROOKINGS, SD 57006

PROJ: OUTDOOR SCOREBOARDS

TITLE: INSTALLATION SPECS; TI-2015

DES. BY: MCOPLAN

DRAWN BY: MCOPLAN

DATE: 19MAR03

01	25 OCT 07	ADDED MILLIMETERS DIMENSIONS	KDD	
REV.	DATE	DESCRIPTION	BY	APPR.

REVISION	APPR. BY:
01	SCALE: 1=50

1091-E10A-173484

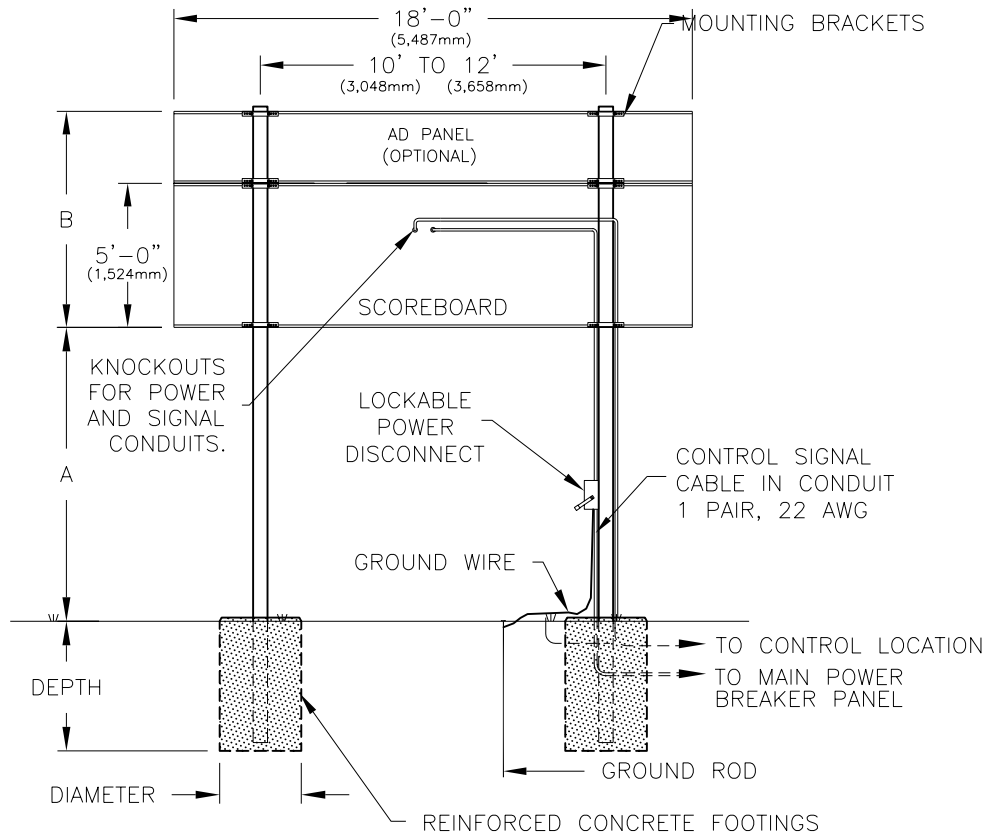

MS-2004
REAR VIEW

MS-2004						
VERTICAL DISTANCE (A)	AD PANEL HEIGHT	COMBINED HEIGHT (B)		DESIGN WIND VELOCITY		
				70 MPH	80 MPH	100 MPH
10 FT	NONE	5'-0"	BEAM	W6X15	W6X15	W8X18
			FOOTING	2.0X5.4	2.0X5.9	2.5X6.4
	2'-0"	7'-0"	BEAM	W8X18	W6X20	W8X24
			FOOTING	2.5X5.7	2.5X6.3	2.5X7.4
12 FT	NONE	5'-0"	BEAM	W6X15	W8X18	W10X22
			FOOTING	2.5X5.2	2.5X5.7	2.5X6.8
	2'-0"	7'-0"	BEAM	W6X20	W10X22	W12X26
			FOOTING	2.5X5.9	2.5X6.5	2.5X7.7
14 FT	NONE	5'-0"	BEAM	W8X18	W10X22	W8X24
			FOOTING	2.5X5.5	2.5X6.0	2.5X7.1
	2'-0"	7'-0"	BEAM	W8X24	W8X24	W8X31
			FOOTING	2.5X6.2	2.5X6.9	2.5X8.1

FOOTING DIMENSIONS ARE SUGGESTIONS ONLY, PROVIDED TO ASSIST WITH ESTIMATING INSTALLATION COSTS AND ARE NOT INTENDED FOR CONSTRUCTION PURPOSES.

FOOTING = DIAMETER X DEPTH

FOOTING DIMENSIONS ARE BASED ON ASSUMED SOIL BEARING PRESSURE OF 2000 LB/FT²

ACTUAL FOOTING DEPTH AND DIAMETER FOR A PARTICULAR INSTALLATION MUST BE DETERMINED BY A QUALIFIED STRUCTURAL ENGINEER, USING DATA FROM A SOIL SAMPLE TEST AT THE SITE.

DAKTRONICS, INC. IS NOT RESPONSIBLE FOR STRUCTURES DESIGNED AND INSTALLED BY OTHERS.

THE CONCEPTS EXPRESSED AND DETAILS SHOWN ON THIS DRAWING ARE CONFIDENTIAL AND PROPRIETARY. DO NOT REPRODUCE BY ANY MEANS, INCLUDING ELECTRONICALLY WITHOUT THE EXPRESSED WRITTEN CONSENT OF DAKTRONICS, INC. COPYRIGHT 2002 DAKTRONICS, INC.

DAKTRONICS, INC. BROOKINGS, SD 57006

PROJ: OUTDOOR LED SCOREBOARDS	
TITLE: INSTALLATION SPECIFICATIONS; MS-2004	
DES. BY: MCOPLAN	DRAWN BY: MCOPLAN
DATE: 03OCT02	
REVISION	APPR. BY:
02	SCALE: 1=80

1192-R10A-176286

02	25 OCT 07	ADDED MILLIMETERS DIMENSIONS	KDD	
01	9 NOV 05	CHANGED POLE SPACING TO 10' - 12'.	JKU	
REV.	DATE	DESCRIPTION	BY	APPR.

BA-515-11/-21

NOTE THAT THE DOOR HAS BEEN REMOVED TO SHOW INTERNAL COMPONENT DETAIL.

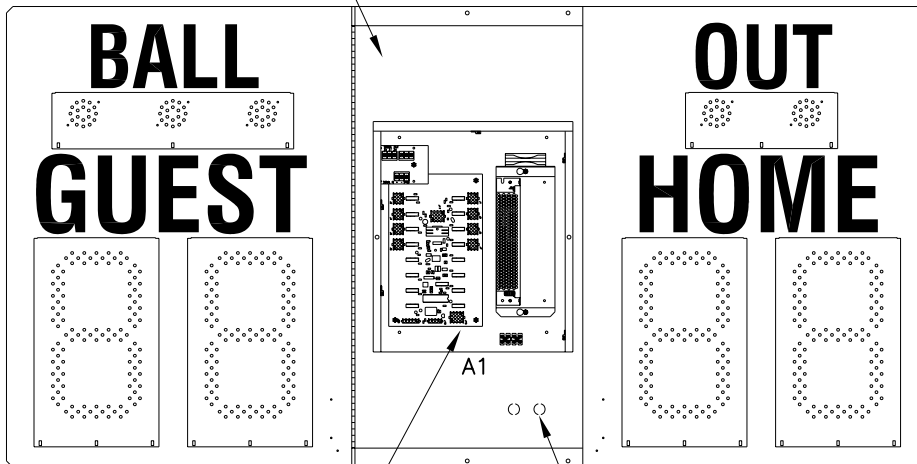



ENCLOSED 8 COLUMN LED DRIVER AND POWER/SIGNAL ENCLOSURE. (THE COVER HAS BEEN REMOVED TO SHOW COMPONENT DETAIL)

KNOCKOUTS FOR CONDUIT

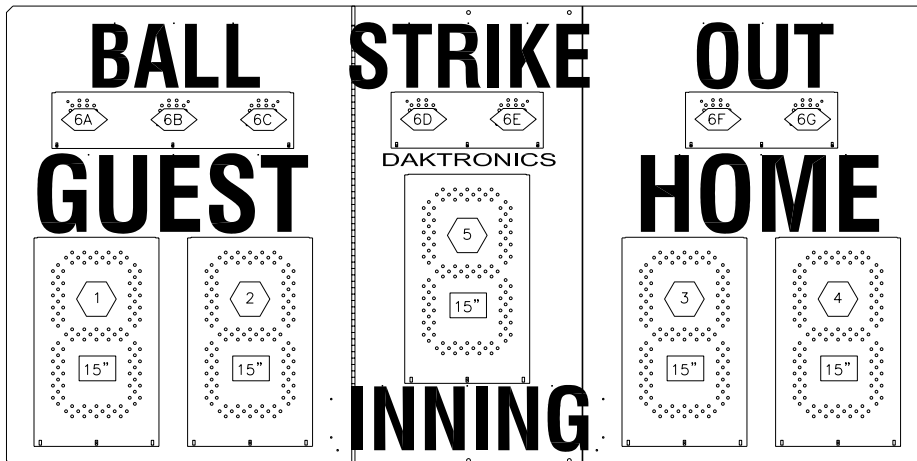
FRONT VIEW
(COMPONENT DETAIL)



FRONT VIEW
(DIGIT DESIGNATION)

-  = DRIVER CONNECTOR WIRED TO THAT DIGIT
-  = DIGIT SIZE
-  = DRIVER CONNECTOR AND SEGMENT (PIN) NUMBER WIRED TO THAT DIGIT

THE CONCEPTS EXPRESSED AND DETAILS SHOWN ON THIS DRAWING ARE CONFIDENTIAL AND PROPRIETARY. DO NOT REPRODUCE BY ANY MEANS, INCLUDING ELECTRONICALLY WITHOUT THE EXPRESSED WRITTEN CONSENT OF DAKTRONICS, INC. COPYRIGHT 2002 DAKTRONICS, INC.

DAKTRONICS, INC. BROOKINGS, SD 57006

PROJ: OUTDOOR LED SCOREBOARDS

TITLE: COMPONENT LOCATIONS; BA-515-11/-21, G3

DES. BY: MCOPLAN

DRAWN BY: MCOPLAN

DATE: 14NOV02

REVISION

APPR. BY:

SCALE: 1=15

1192-R08A-178600

REV.	DATE	DESCRIPTION	BY	APPR.

BA-518-11/-21

ENCLOSED 8 COLUMN LED DRIVER AND POWER/SIGNAL ENCLOSURE. (THE COVER HAS BEEN REMOVED TO SHOW COMPONENT DETAIL).

"STRIKE" AND "INNING" CAPTIONS HAVE BEEN REMOVED FOR DRAWING CLARITY.

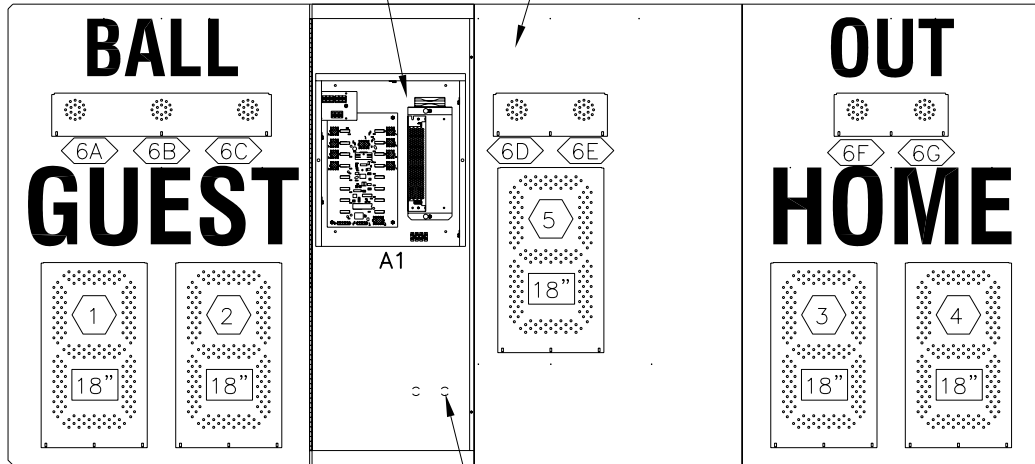

KNOCKOUTS FOR 1/2" CONDUIT

FRONT VIEW

1 = DRIVER CONNECTOR WIRED TO THAT DIGIT.

6A = DRIVER CONNECTOR AND SEGMENT (PIN) NO. WIRED TO THAT INDICATOR

18" = DIGIT SIZE

HINGED ACCESS DOOR REMOVED TO SHOW THE LED DRIVER AND POWER/SIGNAL ENCLOSURE.

THE CONCEPTS EXPRESSED AND DETAILS SHOWN ON THIS DRAWING ARE CONFIDENTIAL AND PROPRIETARY. DO NOT REPRODUCE BY ANY MEANS, INCLUDING ELECTRONICALLY WITHOUT THE EXPRESSED WRITTEN CONSENT OF DAKTRONICS, INC. COPYRIGHT 2002 DAKTRONICS, INC.			
DAKTRONICS, INC. BROOKINGS, SD 57006			
PROJ: OUTDOOR LED SCOREBOARDS			
TITLE: COMPONENT LOCATIONS; BA-518-11/-21, G3			
DES. BY: MCOPLAN		DRAWN BY: MCOPLAN	
		DATE: 15NOV02	
REVISION	APPR. BY:	1192-R08A-178696	
	SCALE: 1=20		

REV.	DATE	DESCRIPTION	BY	APPR.

BA-718-11/-21

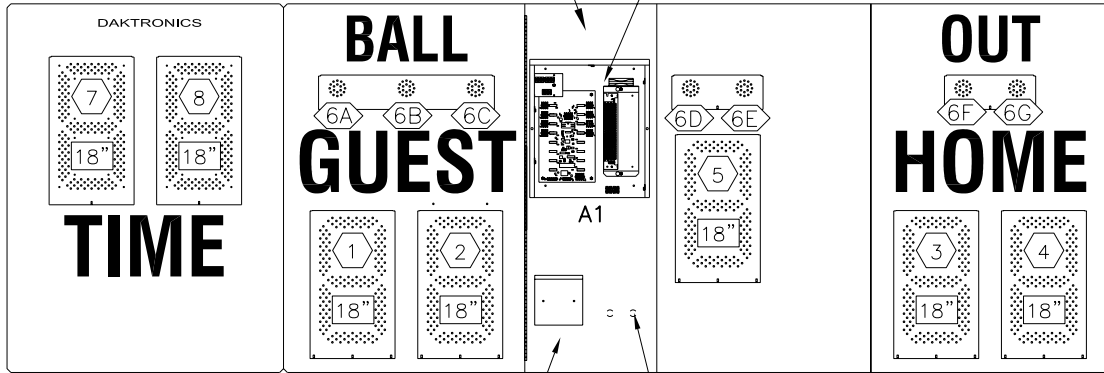

"STRIKE" AND "INNING" CAPTIONS HAVE BEEN REMOVED FOR DRAWING CLARITY.

ENCLOSED 8 COLUMN LED DRIVER AND POWER/SIGNAL ENCLOSURE. (THE COVER HAS BEEN REMOVED TO SHOW THE COMPONENT DETAIL).



HORN (OPTIONAL) KNOCKOUTS FOR 1/2" CONDUIT

FRONT VIEW

-  = LED DRIVER CONNECTOR WIRED TO THAT DIGIT.
-  = LED DRIVER CONNECTOR AND SEGMENT (PIN) NO. WIRED TO THAT INDICATOR
-  = DIGIT SIZE

HINGED ACCESS DOOR REMOVED TO SHOW THE LED DRIVER AND POWER/SIGNAL ENCLOSURE.

THE CONCEPTS EXPRESSED AND DETAILS SHOWN ON THIS DRAWING ARE CONFIDENTIAL AND PROPRIETARY. DO NOT REPRODUCE BY ANY MEANS, INCLUDING ELECTRONICALLY WITHOUT THE EXPRESSED WRITTEN CONSENT OF DAKTRONICS, INC. COPYRIGHT 2002 DAKTRONICS, INC.			
DAKTRONICS, INC. BROOKINGS, SD 57006			
PROJ: OUTDOOR LED SCOREBOARDS			
TITLE: COMPONENT LOCATIONS; BA-718-11/-21, G3			
DES. BY: MCOPLAN		DRAWN BY: MCOPLAN	
		DATE: 18AUG02	
REVISION	APPR. BY:	1192-R08A-178784	
	SCALE: 1=25		

REV.	DATE	DESCRIPTION	BY	APPR.

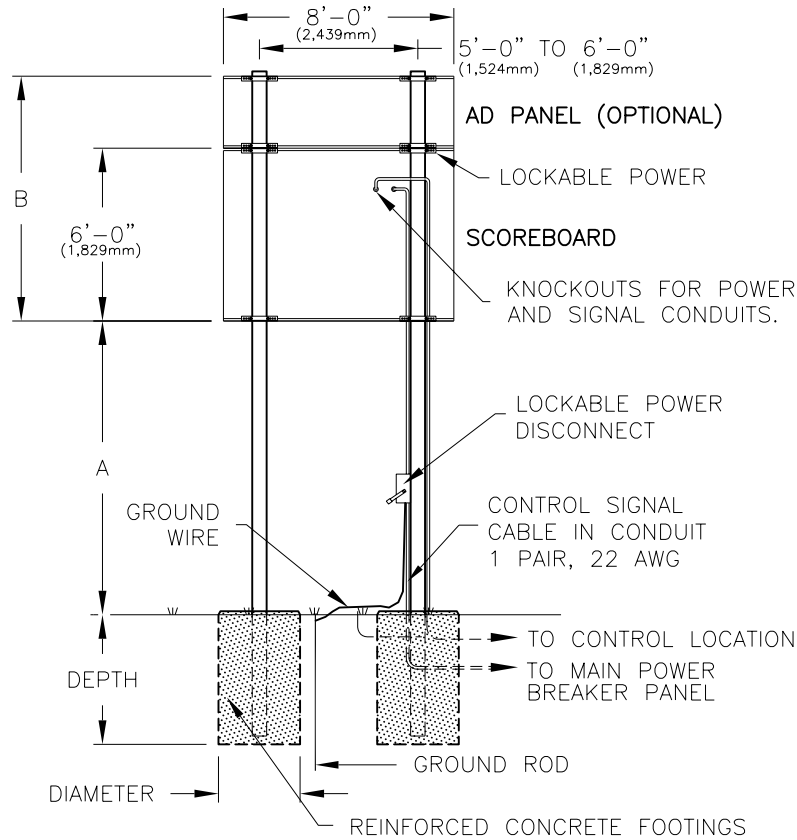

BA-2010
REAR VIEW

BA-2010						
VERTICAL DISTANCE (A)	AD PANEL HEIGHT	COMBINED HEIGHT (B)		DESIGN WIND VELOCITY		
				70 MPH	80 MPH	100 MPH
10 FT	NONE	6'-0"	BEAM	W6X12	W10X15	W6X15
			FOOTING	2.0X5.0	2.0X5.5	2.0X6.5
	2'-0"	8'-0"	BEAM	W6X15	W6X15	W6X20
			FOOTING	2.0X5.6	2.0X6.2	2.0X7.3
12 FT	NONE	6'-0"	BEAM	W6X15	W6X15	W8X18
			FOOTING	2.0X5.3	2.0X5.9	2.0X6.9
	2'-0"	8'-0"	BEAM	W6X15	W8X18	W8X24
			FOOTING	2.0X5.9	2.0X6.5	2.0X7.6
14 FT	NONE	6'-0"	BEAM	W6X15	W8X18	W10X22
			FOOTING	2.0X5.6	2.0X6.1	2.0X7.2
	2'-0"	8'-0"	BEAM	W6X20	W6X20	W8X24
			FOOTING	2.0X6.2	2.0X6.8	2.0X8.0

FOOTING DIMENSIONS ARE SUGGESTIONS ONLY, PROVIDED TO ASSIST WITH ESTIMATING INSTALLATION COSTS AND ARE NOT INTENDED FOR CONSTRUCTION PURPOSES.

FOOTING = DIAMETER X DEPTH

FOOTING DIMENSIONS ARE BASED ON ASSUMED SOIL BEARING PRESSURE OF 2000 LB/FT²

ACTUAL FOOTING DEPTH AND DIAMETER FOR A PARTICULAR INSTALLATION MUST BE DETERMINED BY A QUALIFIED STRUCTURAL ENGINEER, USING DATA FROM A SOIL SAMPLE TEST AT THE SITE.

DAKTRONICS, INC. IS NOT RESPONSIBLE FOR STRUCTURES DESIGNED AND INSTALLED BY OTHERS.

THE CONCEPTS EXPRESSED AND DETAILS SHOWN ON THIS DRAWING ARE CONFIDENTIAL AND PROPRIETARY. DO NOT REPRODUCE BY ANY MEANS, INCLUDING ELECTRONICALLY WITHOUT THE EXPRESSED WRITTEN CONSENT OF DAKTRONICS, INC. COPYRIGHT 2002 DAKTRONICS, INC.

DAKTRONICS, INC. BROOKINGS, SD 57006

PROJ: **OUTDOOR LED SCOREBOARDS**

TITLE: **INSTALLATION SPECIFICATIONS; BA-2010**

DES. BY: **MCOPL/RNEYEN** DRAWN BY: **MCOPLAN** DATE: **27NOV02**

01	25 OCT 07	ADDED MILLIMETERS DIMENSIONS	KDD	
REV.	DATE	DESCRIPTION	BY	APPR.

REVISION	APPR. BY:
01	SCALE: 1=80

1192-R10A-179304

REV.	DATE	DESCRIPTION	BY	APPR.
01	20 FEB 03	CORRECTED SPELLING ON NEUT ADDED 16 COL. WIDE PART NUMBER	MMM	
02	09 NOV 06	UPDATED DRAWING TO SHOW GEN III OR IV DESIGN.	MMM	

PROJ:	OUTDOOR LED SCOREBOARDS
TITLE:	SCHEMATIC; GEN III & IV OD LED, 3 DRVYR DISPLAY
DES. BY:	MILLER
APPR. BY:	MILLER
DATE:	04 DEC 02
REVISION	SCALE: NONE
02	1192-R10A-179541

THE CONCEPTS EXPRESSED AND DETAILS SHOWN ON THIS DRAWING ARE CONFIDENTIAL AND PROPRIETARY. DO NOT REPRODUCE BY ANY MEANS, INCLUDING ELECTRONICALLY WITHOUT THE EXPRESSED WRITTEN CONSENT OF DAKTRONICS, INC. COPYRIGHT 2002 DAKTRONICS, INC.

DAKTRONICS, INC. BROOKINGS, SD 57006

THIS SCHEMATIC REPRESENTS THE INTERCONNECT OF THE MASTER DRIVER TO OTHER DRIVERS/TNMC'S IN A MULTI DRIVER SCOREBOARD CONFIGURATION. SEE THE PRE-PAINT ASSEMBLY DRAWING AND/OR THE FINAL ASSEMBLY DRAWING FOR THE PART NUMBERS OF THE INTERCONNECT HARNESSES NEEDED AND INSTALLATION INSTRUCTIONS.

PWR/SIG INTERCONNECT HARNESS

PART NUMBER	LENGTH
0A-1192-1028	4'
0A-1192-1029	8'
0A-1192-1030	10'
0A-1192-1031	12'
0A-1192-1032	16'
0A-1192-1033	22'
0A-1192-1034	26'
0A-1192-1083	30'
0A-1192-1084	35'

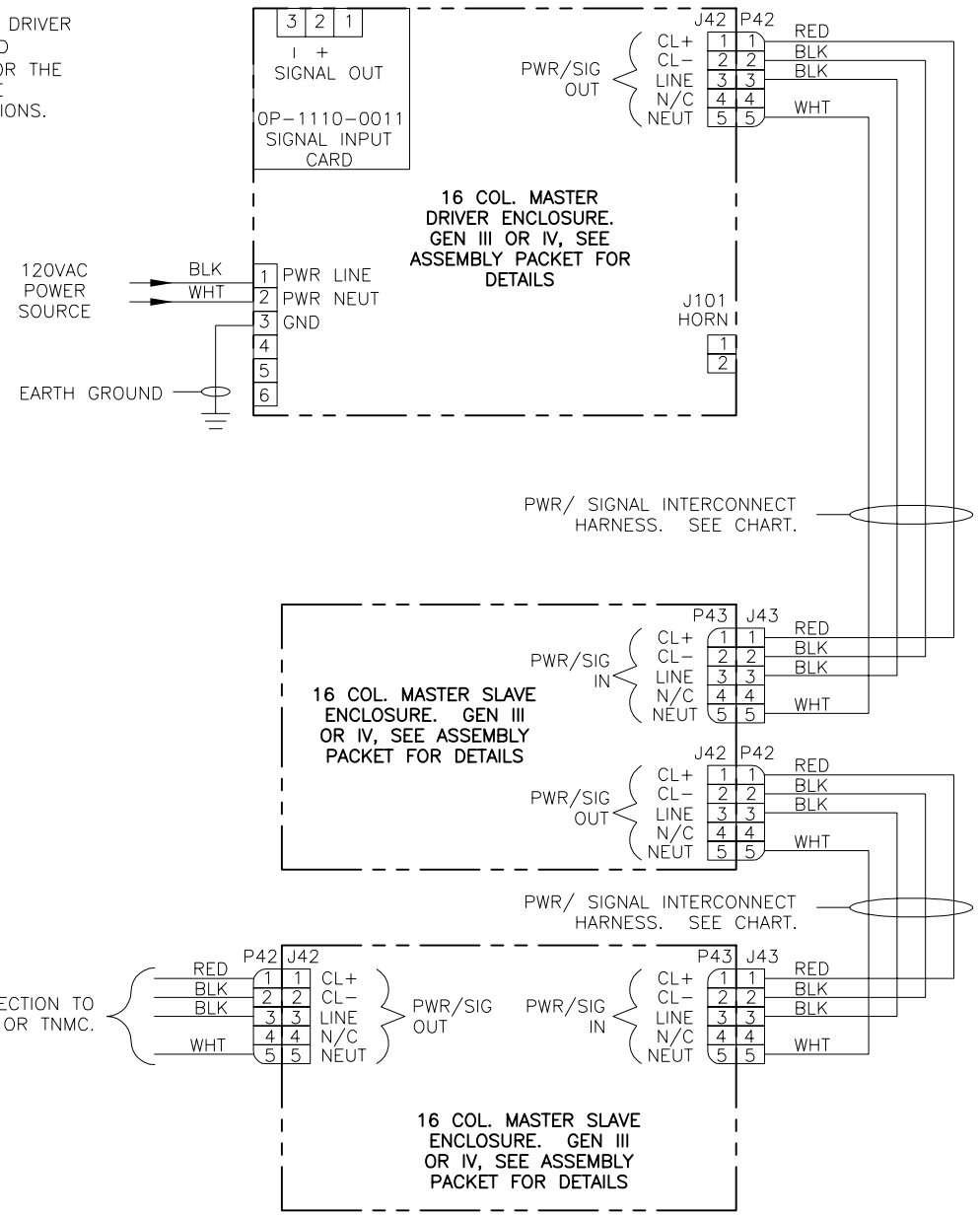

DAKTRONICS, INC. BROOKINGS, SD 57006

REV.	DATE	DESCRIPTION	BY	APPR.
02	08 MAY-03	CHANGED TNMC TEXT TO NEW GEN 3 AND ADDED NOTE	TAS	MMM
01	20 FEB 03	ADDED 16 COL. WIDE PART NUMBER AND CORRECTED SPELLING ON NEUT	MMM	

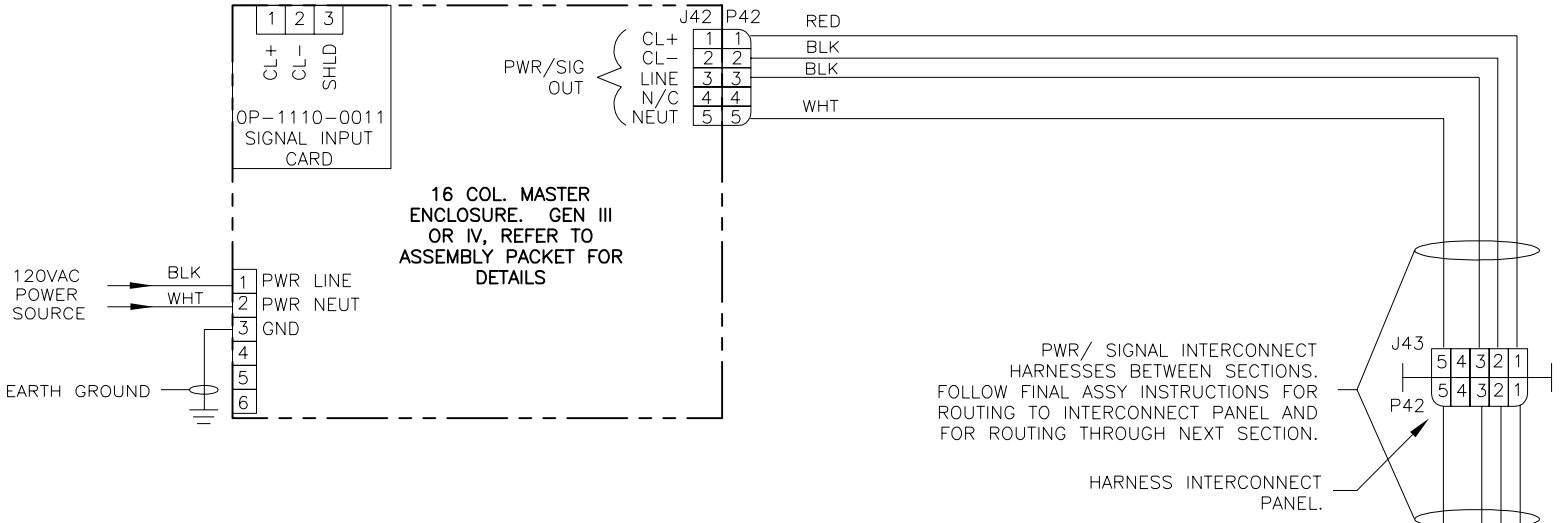

PWR/ SIGNAL INTERCONNECT HARNESES BETWEEN SECTIONS. FOLLOW FINAL ASSY INSTRUCTIONS FOR ROUTING TO INTERCONNECT PANEL AND FOR ROUTING THROUGH NEXT SECTION.

HARNESS INTERCONNECT PANEL.

THIS SCHEMATIC REPRESENTS THE INTERCONNECT OF THE MASTER DRIVER TO OTHER DRIVERS/TNMC'S IN A MULTI DRIVER SCOREBOARD CONFIGURATION. SEE THE PRE-PAINT ASSEMBLY DRAWING AND/OR THE FINAL ASSEMBLY DRAWING FOR THE PART NUMBERS OF THE INTERCONNECT HARNESES NEEDED AND INSTALLATION INSTRUCTIONS.

PWR/SIG INTERCONNECT HARNESS

PART NUMBER	LENGTH
0A-1192-1028	4'
0A-1192-1029	8'
0A-1192-1030	10'
0A-1192-1031	12'
0A-1192-1032	16'
0A-1192-1033	22'
0A-1192-1034	26'
0A-1192-1083	30'
0A-1192-1084	35'

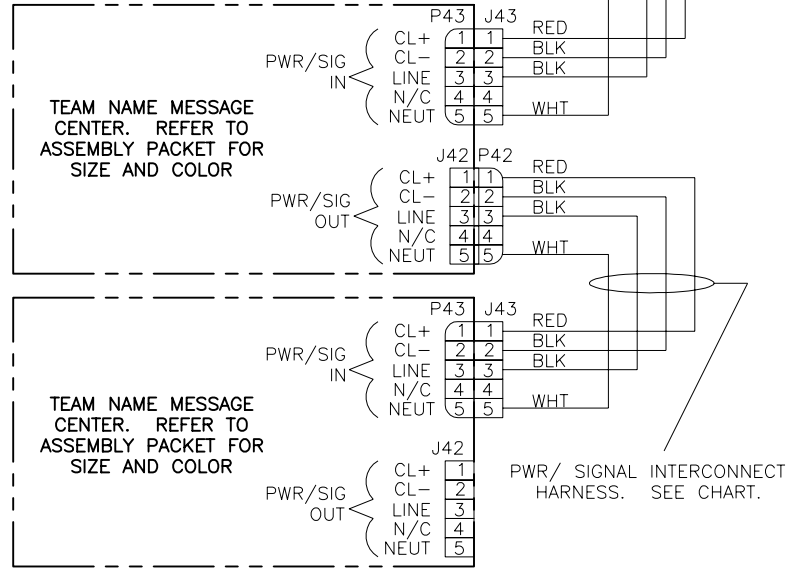

NOTE:
CONNECT THE RIBBON CABLE TO THE TNMC DRIVER TO EITHER
J25 = HOME OR
J26 = GUEST.

PROJ: OUTDOOR LED DIGIT SCOREBOARDS
 TITLE: SCHEMATIC; GEN III & IV OD LED, 1 DRV W/ TNMC
 DES. BY: ALINDHO DATE: 17 DEC 02
 DRAWN BY: ALINDHO

REVISION 02 APPR. BY: NONE SCALE: NONE

1192-R01A-179790

THE CONCEPTS EXPRESSED AND DETAILS SHOWN ON THIS DRAWING ARE CONFIDENTIAL AND PROPRIETARY. DO NOT REPRODUCE BY ANY MEANS, INCLUDING ELECTRONICALLY WITHOUT THE EXPRESSED WRITTEN CONSENT OF DAKTRONICS, INC. COPYRIGHT 2002 DAKTRONICS, INC.

DAKTRONICS, INC. BROOKINGS, SD 57006

REV.	DATE	DESCRIPTION	BY	APPR.
01	20 FEB 03	CORRECTED SPELLING ON NEUT ADDED 16 COL. WIDE PART NUMBERS.	MMM	
02	08 MAY-03	CHANGED TNMC TEXT TO NEW GEN 3 AND ADDED NOTE.	TAS	MMM

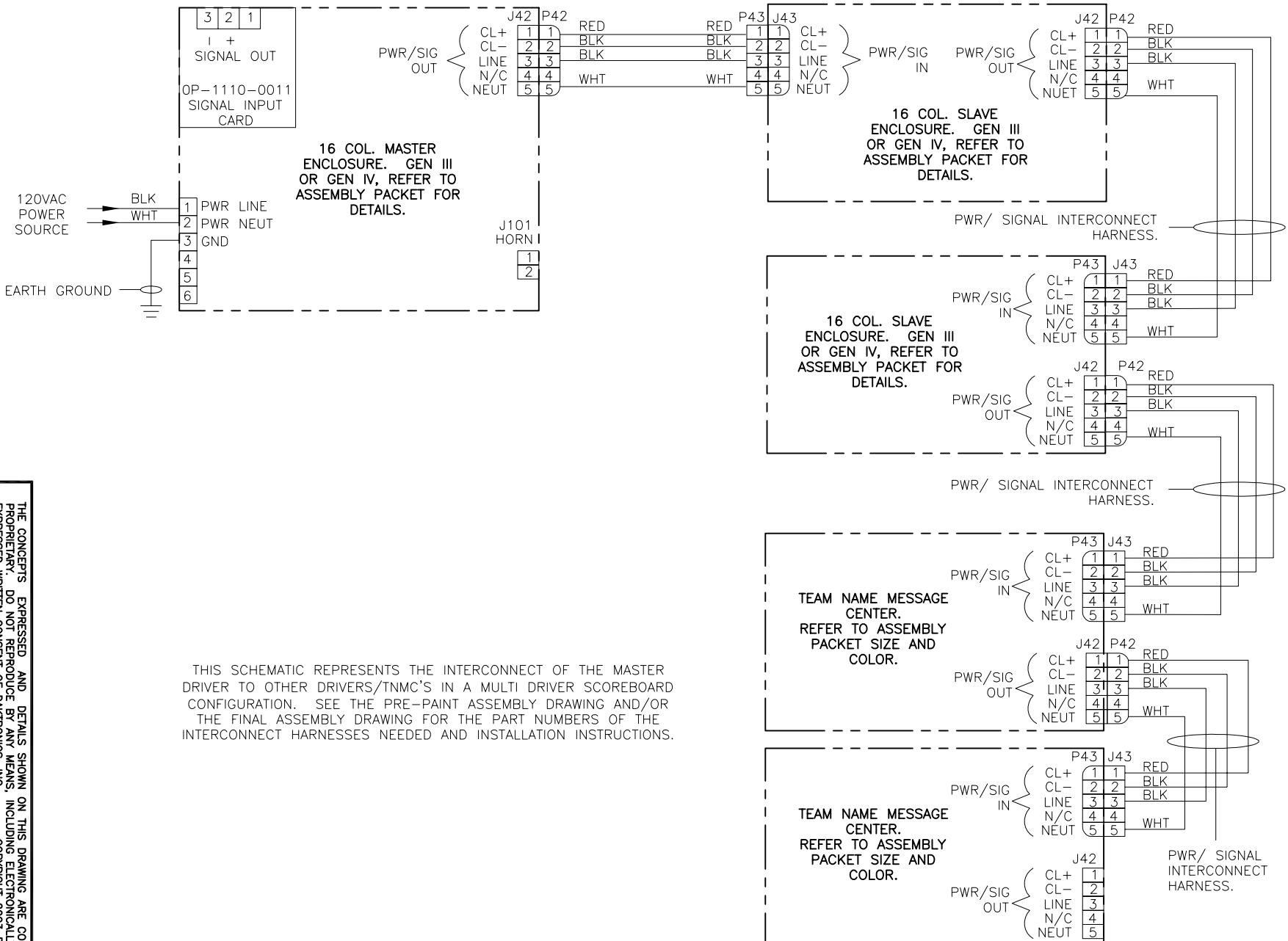

THIS SCHEMATIC REPRESENTS THE INTERCONNECT OF THE MASTER DRIVER TO OTHER DRIVERS/TNMC'S IN A MULTI DRIVER SCOREBOARD CONFIGURATION. SEE THE PRE-PAINT ASSEMBLY DRAWING AND/OR THE FINAL ASSEMBLY DRAWING FOR THE PART NUMBERS OF THE INTERCONNECT HARNESSES NEEDED AND INSTALLATION INSTRUCTIONS.

NOTE:
CONNECT THE RIBBON CABLE TO THE TNMC DRIVER TO EITHER
J25 = HOME OR
J26 = GUEST.

PROJ: OUTDOOR LED DIGIT SCOREBOARDS
TITLE: SCHEMATIC; GEN III & IV, 3 DRV W/ TNMC
DES. BY: ALINDHO
DRAWN BY: ALINDHO
DATE: 18 DEC 02

REVISION 02
APPR. BY: NONE
SCALE: NONE

1192-R10A-180081

THE CONCEPTS EXPRESSED AND DETAILS SHOWN ON THIS DRAWING ARE CONFIDENTIAL AND PROPRIETARY. DO NOT REPRODUCE BY ANY MEANS, INCLUDING ELECTRONICALLY WITHOUT THE EXPRESSED WRITTEN CONSENT OF DAKTRONICS, INC. COPYRIGHT 2003 DAKTRONICS, INC.

DAKTRONICS, INC. BROOKINGS, SD 57006

BA-2003-11/-21

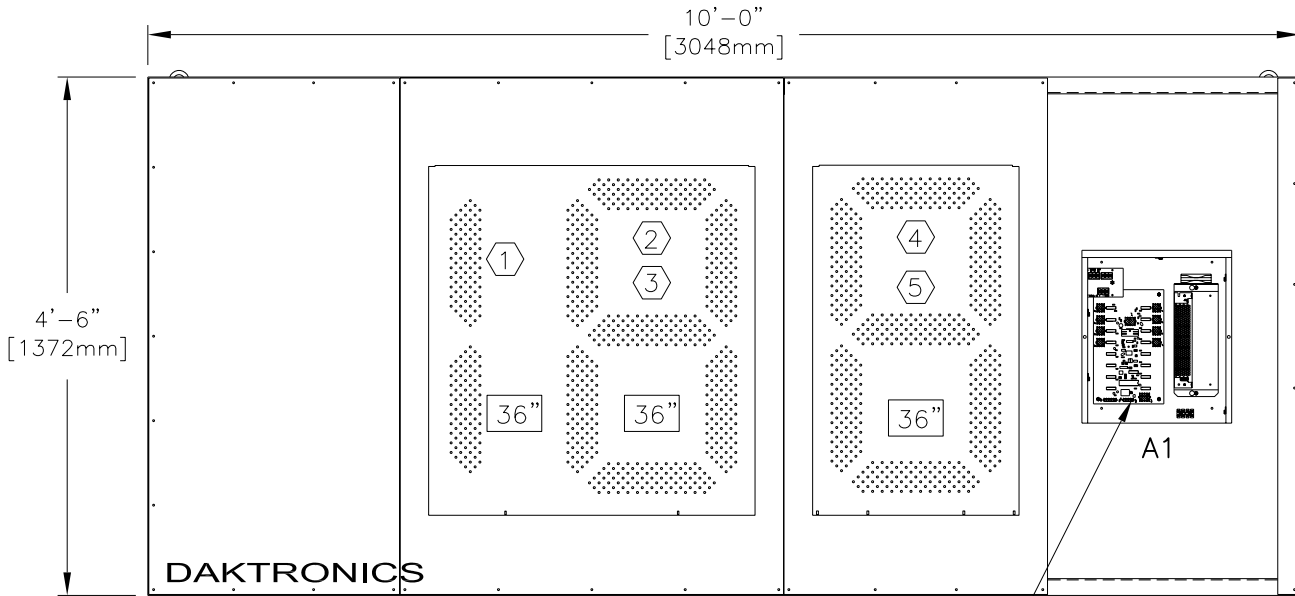

ENCLOSED 16 COLUMN LED DRIVER AND POWER/SIGNAL ENCLOSURE. (THE COVER HAS BEEN REMOVED TO SHOW THE COMPONENT DETAIL).

FRONT VIEW

① = DRIVER CONNECTOR WIRED TO THAT DIGIT.

36" = DIGIT SIZE

HINGED ACCESS DOOR SHOWN REMOVED TO SHOW INTERNAL ELECTRICAL COMPONENTS.

THE CONCEPTS EXPRESSED AND DETAILS SHOWN ON THIS DRAWING ARE CONFIDENTIAL AND PROPRIETARY. DO NOT REPRODUCE BY ANY MEANS, INCLUDING ELECTRONICALLY WITHOUT THE EXPRESSED WRITTEN CONSENT OF DAKTRONICS, INC. COPYRIGHT 2002 DAKTRONICS, INC.

DAKTRONICS, INC. BROOKINGS, SD 57006

PROJ: OUTDOOR LED DIGIT SCOREBOARDS

TITLE: COMPONENT LOCATIONS, BA-2003-11/-21, G3

DES. BY: MCOPLAN

DRAWN BY: MCOPLAN

DATE: 26DEC02

01	19FEB03	ADDED DIMENSIONS TO DISPLAY	MCOPL	
REV.	DATE	DESCRIPTION	BY	APPR.

REVISION	APPR. BY:	
	SCALE:	1=20

1192-R08A-180362

MS-915-11/-21

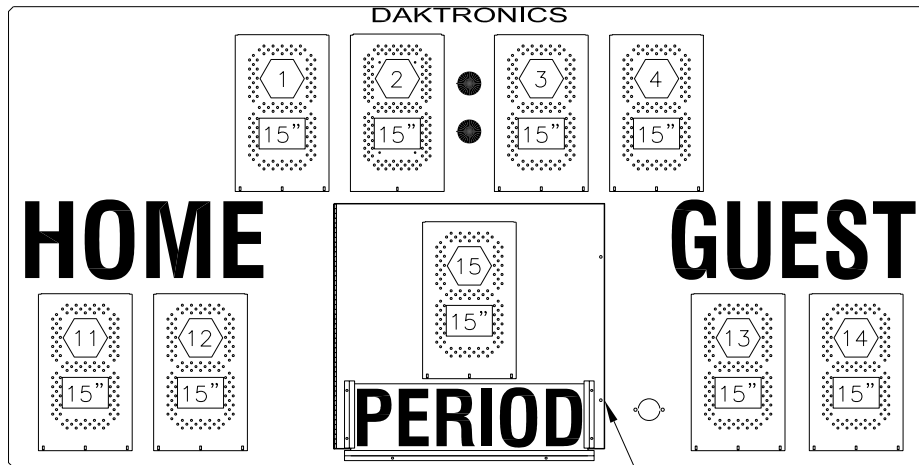

FRONT VIEW

REMOVE SCREWS TO ACCESS LED DRIVER & ENTRANCE

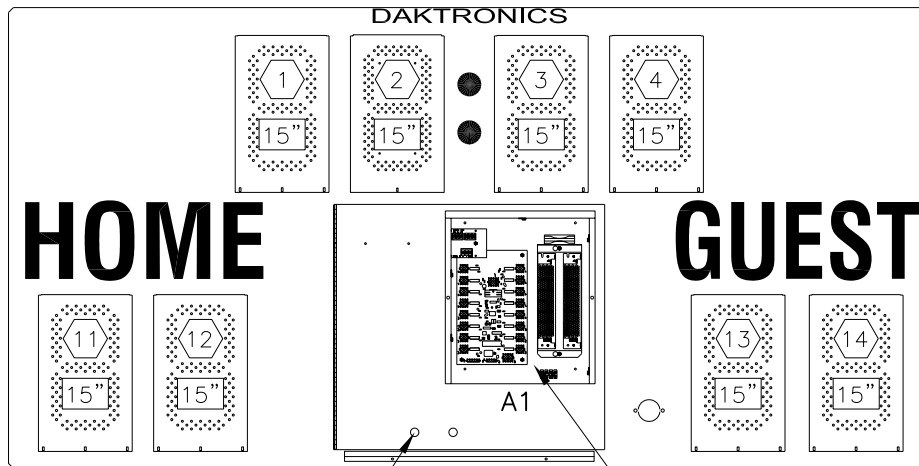

FRONT VIEW

KNOCKOUTS FOR 1/2" CONDUIT

ENCLOSED 16 COLUMN LED DRIVER AND POWER/SIGNAL ENCLOSURE. (THE COVER HAS BEEN REMOVED TO SHOW THE COMPONENT DETAIL).

① = LED DRIVER CONNECTOR WIRED TO THAT DIGIT.

15" = DIGIT SIZE

HINGED ACCESS DOOR REMOVED TO SHOW THE LED DRIVER AND POWER/SIGNAL ENCLOSURE.

THE CONCEPTS EXPRESSED AND DETAILS SHOWN ON THIS DRAWING ARE CONFIDENTIAL AND PROPRIETARY. DO NOT REPRODUCE BY ANY MEANS, INCLUDING ELECTRONICALLY WITHOUT THE EXPRESSED WRITTEN CONSENT OF DAKTRONICS, INC. COPYRIGHT 2002 DAKTRONICS, INC.

DAKTRONICS, INC. BROOKINGS, SD 57006

PROJ: OUTDOOR LED SCOREBOARDS

TITLE: COMPONENT LOCATIONS; MS-915-11/-21, G3

DES. BY: MCOPLAN

DRAWN BY: MCOPLAN

DATE: 26DEC02

REVISION

APPR. BY:

02

SCALE: 1=20

1192-R08A-180365

02	14 APR 05	ADDED HORN HOLES TO FRONT VIEWS	EKT
01	07NOV03	MADE WIDTH OF DOOR NARROWER	MCOPL
REV.	DATE	DESCRIPTION	BY APPR.

REV.	01	DATE	20 FEB 03	DESCRIPTION	CORRECTED SPELLING ON NEUT ADDED 18 COL. WIDE PART NUMBERS.	BY	MMM	APPR.
------	----	------	-----------	-------------	---	----	-----	-------

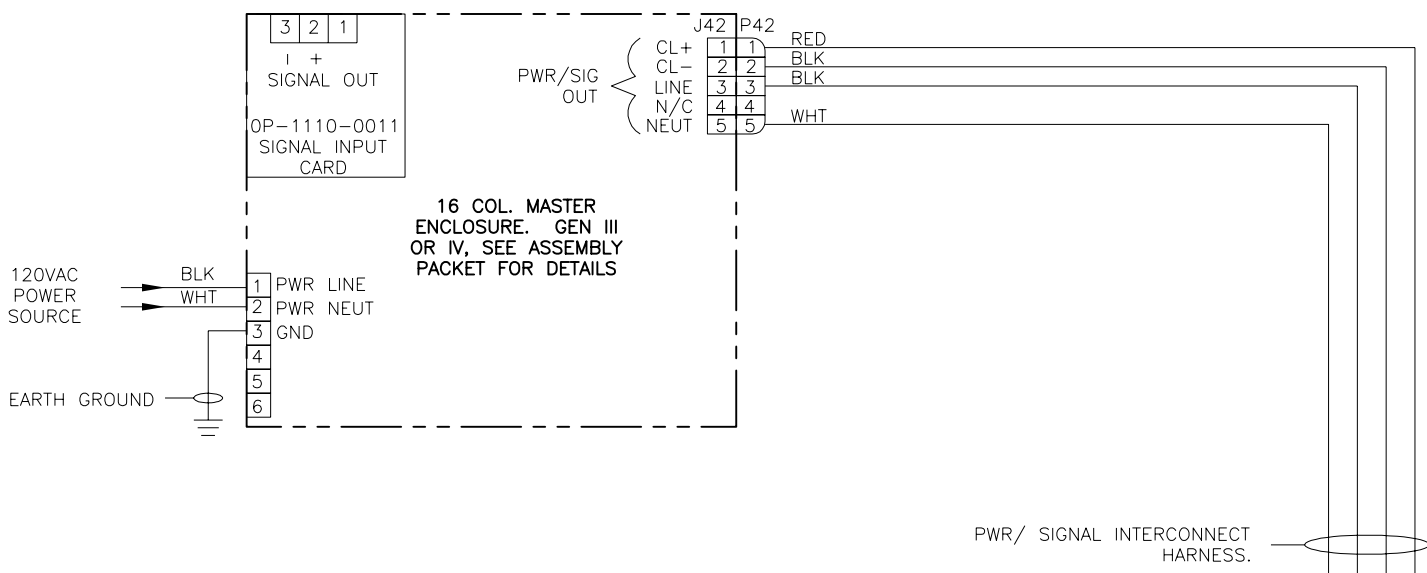

THE CONCEPTS EXPRESSED AND DETAILS SHOWN ON THIS DRAWING ARE CONFIDENTIAL AND PROPRIETARY. DO NOT REPRODUCE BY ANY MEANS, INCLUDING ELECTRONICALLY WITHOUT THE EXPRESSED WRITTEN CONSENT OF DAKTRONICS, INC. COPYRIGHT 2002 DAKTRONICS, INC.	
PROJ: OUTDOOR LED SCOREBOARDS TITLE: SCHEMATIC; GEN III & IV O.D. LED, 2 DRYR DISPLAY DES. BY: MILLER DRAWN BY: MILLER DATE: 03 JAN 02	
REVISION 01	APPR. BY: NONE SCALE: NONE 1192-R10A-180637
DAKTRONICS, INC. BROOKINGS, SD 57006	

PWR/SIG INTERCONNECT HARNESS

PART NUMBER	LENGTH
0A-1192-1028	4'
0A-1192-1029	8'
0A-1192-1030	10'
0A-1192-1031	12'
0A-1192-1032	16'
0A-1192-1033	22'
0A-1192-1034	26'
0A-1192-1083	30'
0A-1192-1084	35'

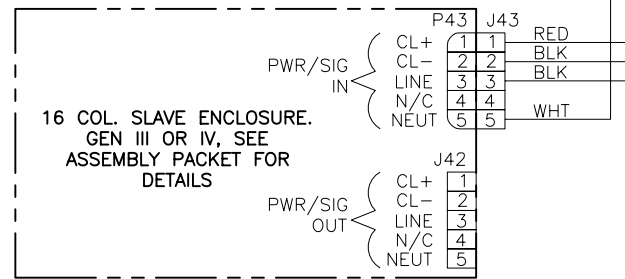

THIS SCHEMATIC REPRESENTS THE INTERCONNECT OF THE MASTER DRIVER TO OTHER DRIVERS/TNMC'S IN A MULTI DRIVER SCOREBOARD CONFIGURATION. SEE THE PRE-PAINT ASSEMBLY DRAWING AND/OR THE FINAL ASSEMBLY DRAWING FOR THE PART NUMBERS OF THE INTERCONNECT HARNESSES NEEDED AND INSTALLATION INSTRUCTIONS.

S0-918-11/-21

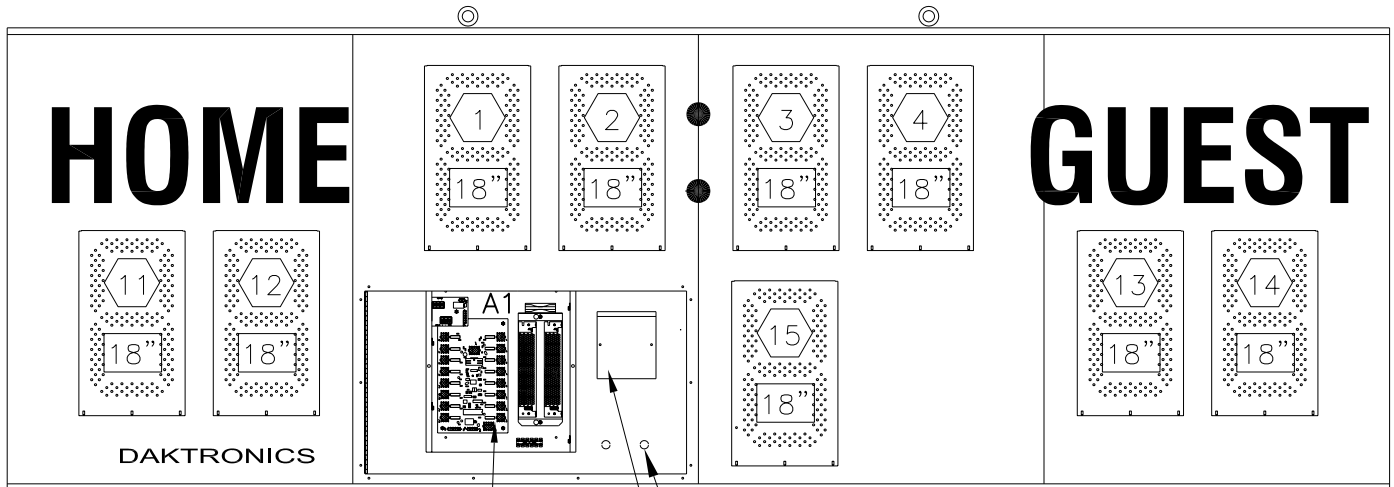

ENCLOSED 16 COLUMN LED DRIVER AND POWER/SIGNAL ENCLOSURE. (THE COVER HAS BEEN REMOVED TO SHOW THE COMPONENT DETAIL).

KNOCKOUTS FOR 1/2" CONDUIT
HORN (OPTIONAL)

FRONT VIEW

12 = LED DRIVER CONNECTOR WIRED TO THAT DIGIT.

18" = DIGIT SIZE

HINGED ACCESS DOORS REMOVED TO SHOW LED DRIVER AND THE POWER AND SIGNAL ENCLOSURE.

THE CONCEPTS EXPRESSED AND DETAILS SHOWN ON THIS DRAWING ARE CONFIDENTIAL AND PROPRIETARY. DO NOT REPRODUCE BY ANY MEANS, INCLUDING ELECTRONICALLY WITHOUT THE EXPRESSED WRITTEN CONSENT OF DAKTRONICS, INC. COPYRIGHT 2002 DAKTRONICS, INC.			
DAKTRONICS, INC. BROOKINGS, SD 57006			
PROJ: OUTDOOR LED SCOREBOARDS			
TITLE: COMPONENT LOCATIONS; S0-918-11/-21, G3			
DES. BY: MCOPLAN		DRAWN BY: MCOPLAN	
		DATE: 03JAN03	
REVISION	APPR. BY:	1192-R08A-180835	
01	SCALE: 1=20		

01	14 NOV 06	ELIMINATED DOOR AND MOVED OPTIONAL HORN	AJS	
REV.	DATE	DESCRIPTION	BY	APPR.

TI-418-11/-21

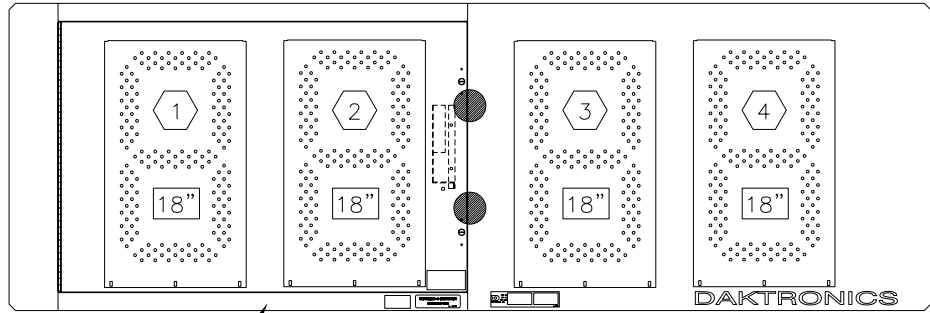

REMOVE THE SCREWS TO ACCESS LED DRIVER & PWR/SIG ENCLOSURE.

FRONT VIEW

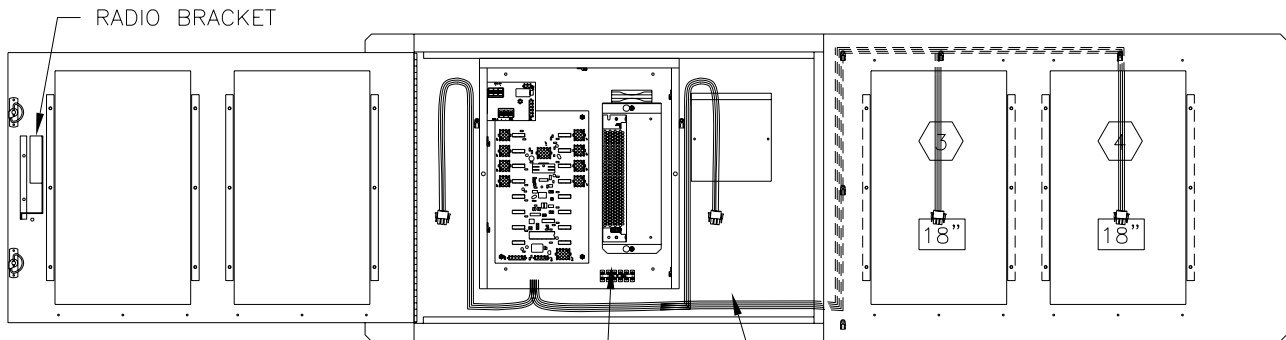

ENCLOSED 8 COLUMN LED DRIVER AND POWER/SIGNAL ENCLOSURE. (THE COVER HAS BEEN REMOVED TO SHOW COMPONENT DETAIL).

KNOCKOUTS FOR 1/2" CONDUIT

FRONT VIEW
ACCESS DOOR OPEN

① = LED DRIVER CONNECTOR WIRED TO THAT DIGIT.

18" = DIGIT SIZE

THE CONCEPTS EXPRESSED AND DETAILS SHOWN ON THIS DRAWING ARE CONFIDENTIAL AND PROPRIETARY. DO NOT REPRODUCE BY ANY MEANS, INCLUDING ELECTRONICALLY WITHOUT THE EXPRESSED WRITTEN CONSENT OF DAKTRONICS, INC. COPYRIGHT 2002 DAKTRONICS, INC.			
DAKTRONICS, INC. BROOKINGS, SD 57006			
PROJ: OUTDOOR LED SCOREBOARDS			
TITLE: COMPONENT LOCATIONS; TI-418-11/-21, G3			
DES. BY: MCOPLAN		DRAWN BY: MCOPLAN	
		DATE: 09JAN03	
REVISION	APPR. BY:	1192-R08A-181177	
01	SCALE: 1=15		

01	25AUG06	ADDED RADIO BRACKET & UPDATED METAL PARTS	TAJ	
REV.	DATE	DESCRIPTION	BY	APPR.

TI-218-11/-21

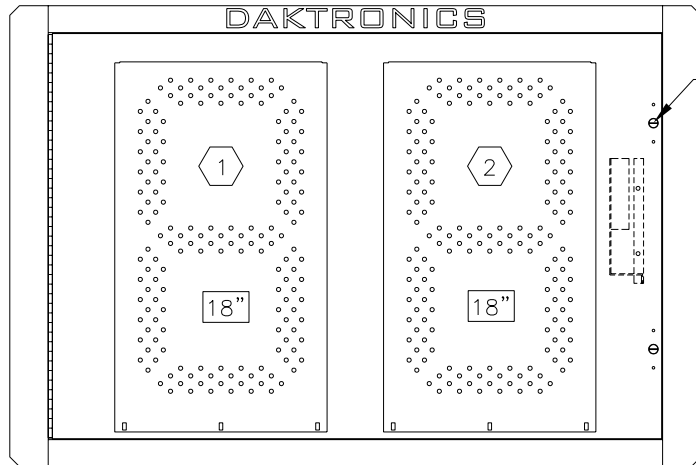

FRONT VIEW

1 = LED DRIVER CONNECTOR WIRED TO THAT DIGIT.

18" = DIGIT SIZE

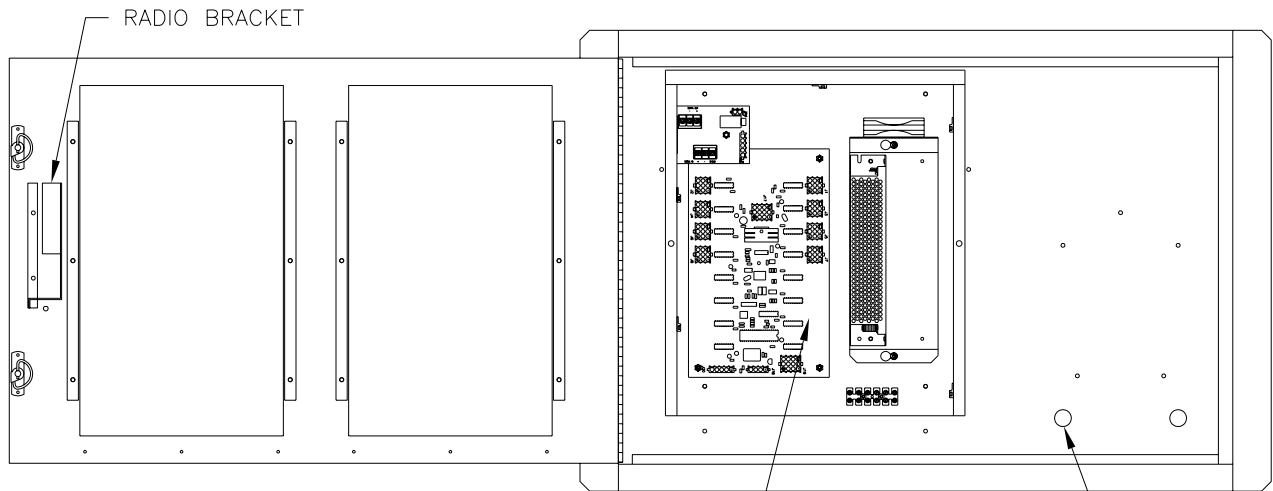

ENCLOSED 8 COLUMN LED DRIVER AND POWER/SIGNAL ENCLOSURE. (THE COVER HAS BEEN REMOVED TO SHOW THE COMPONENT DETAIL).

FRONT VIEW
ACCESS DOOR OPEN

KNOCKOUTS FOR 1/2" CONDUIT

THE CONCEPTS EXPRESSED AND DETAILS SHOWN ON THIS DRAWING ARE CONFIDENTIAL AND PROPRIETARY. DO NOT REPRODUCE BY ANY MEANS, INCLUDING ELECTRONICALLY WITHOUT THE EXPRESSED WRITTEN CONSENT OF DAKTRONICS, INC. COPYRIGHT 2002 DAKTRONICS, INC.

DAKTRONICS, INC. BROOKINGS, SD 57006

PROJ: OUTDOOR LED SCOREBOARDS

TITLE: COMPONENT LOCATIONS; TI-218-11/-21, G3

DES. BY: MCOPLAN

DRAWN BY: MCOPLAN

DATE: 17JAN03

REV.	DATE	DESCRIPTION	BY	APPR.
01	25AUG06	ADDED RADIO BRACKET & UPDATED METAL PARTS	TAJ	

REVISION	APPR. BY:
01	
	SCALE:
	1=10

1192-R08A-181701

TI-2012-11/-21

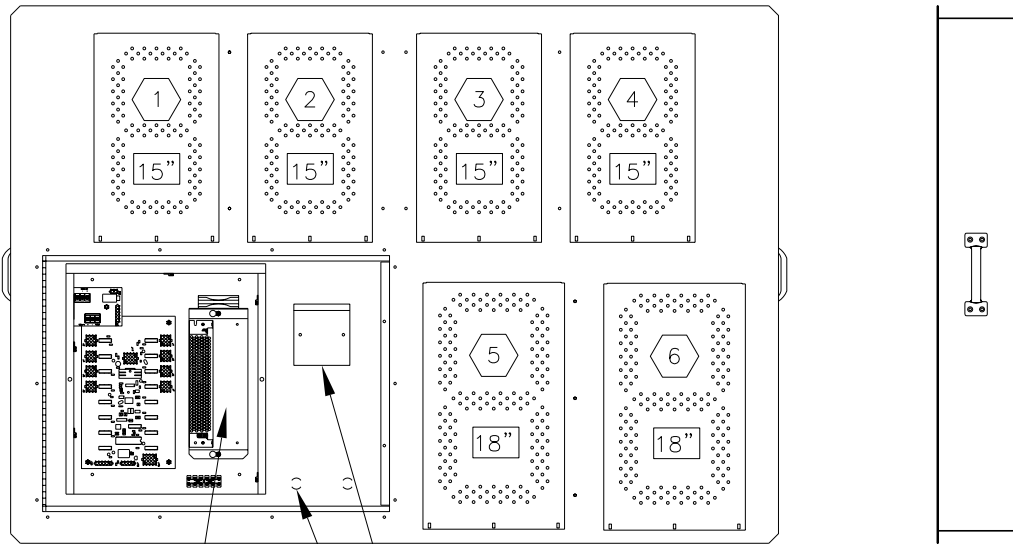

ENCLOSED 8 COLUMN LED DRIVER AND POWER/SIGNAL ENCLOSURE. (THE DOOR IS OPENED TO SHOW THE LED DRIVER.)

HORN ENCLOSURE

KNOCKOUTS FOR CONDUIT

FRONT VIEW

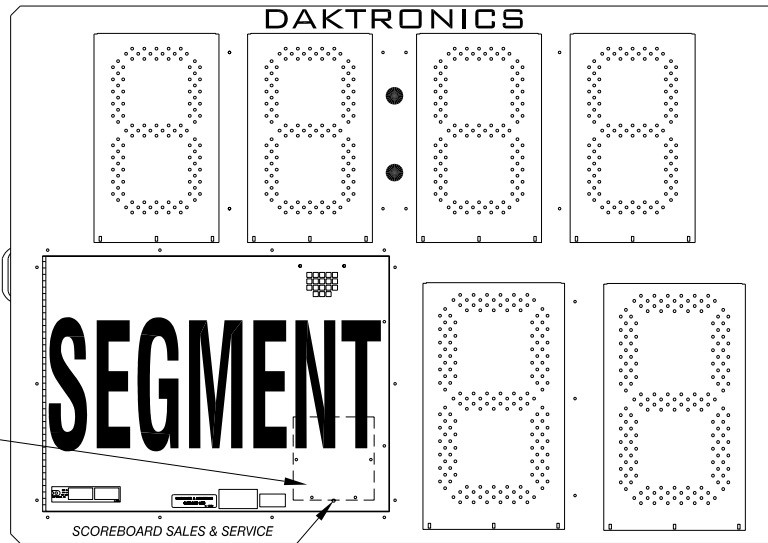

RADIO BRACKET

ANTENNA HOLE

FRONT VIEW

1 = LED DRIVER CONNECTOR WIRED TO THAT DIGIT.

18" = DIGIT SIZE

THE CONCEPTS EXPRESSED AND DETAILS SHOWN ON THIS DRAWING ARE CONFIDENTIAL AND PROPRIETARY. DO NOT REPRODUCE BY ANY MEANS, INCLUDING ELECTRONICALLY WITHOUT THE EXPRESSED WRITTEN CONSENT OF DAKTRONICS, INC. COPYRIGHT 2002 DAKTRONICS, INC.			
DAKTRONICS, INC. BROOKINGS, SD 57006			
PROJ: OUTDOOR LED SCOREBOARDS			
TITLE: COMPONENT LOCATIONS; TI-2012-11/-21, G3			
DES. BY: MCOPLAN		DRAWN BY: MCOPLAN	
		DATE: 24JAN03	
REVISION	APPR. BY:	1192-R08A-182081	
01	SCALE: 1=15		

01	21SEPT06	ADDED RADIO BRACKET	TAJ	
REV.	DATE	DESCRIPTION	BY	APPR.

TI-2019-11/-21

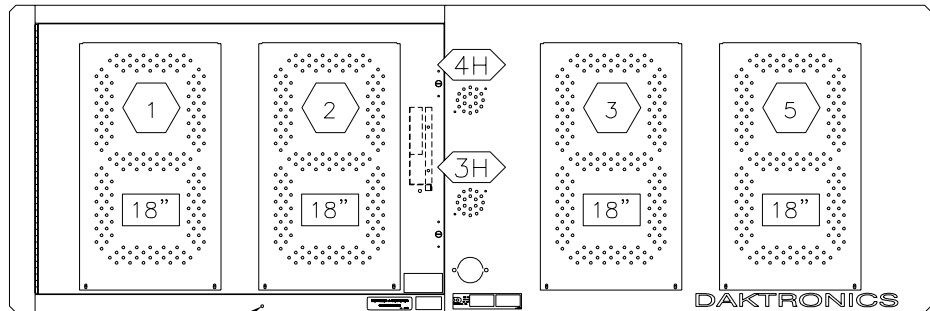

DOOR SHOWN CLOSED. REMOVE SCREWS @3 TO TO ACCESS THE DRIVER AND THE POWER & SIGNAL ENCLOSURE.

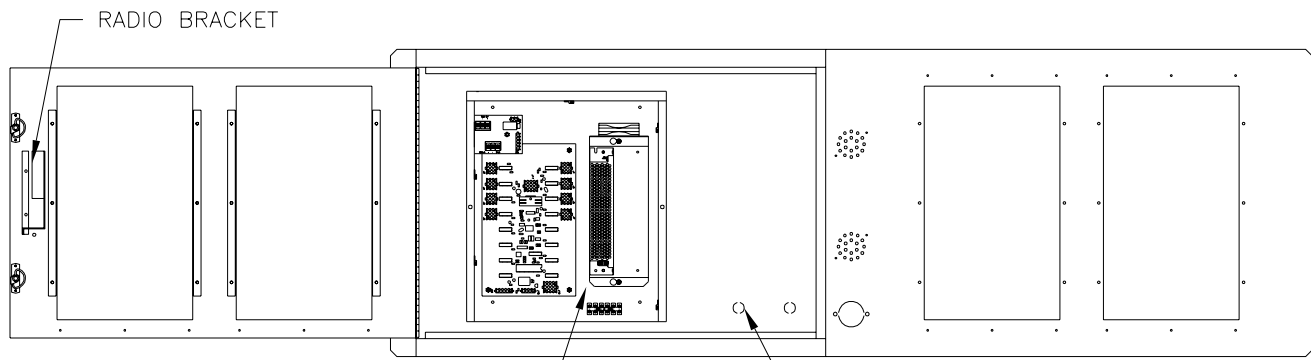

ENCLOSED 8 COLUMN LED DRIVER AND POWER & SIGNAL ENCLOSURE. (THE DRIVER COVER HAS BEEN REMOVED TO SHOW THE COMPONENT DETAIL).

- = LED DRIVER CONNECTOR WIRED TO THAT DIGIT.
- = LED DRIVER CONNECTOR AND SEGMENT (PIN) NO. WIRED TO THAT INDICATOR
-

REV.	01	DATE	25AUG06	DESCRIPTION	ADDED RADIO BRACKET & UPDATED METAL PARTS	BY	TJM	APPR.
------	----	------	---------	-------------	---	----	-----	-------

PROJ: OUTDOOR LED SCOREBOARDS
 TITLE: COMPONENT LOCATIONS; TI-2019-11/-21, G3
 DES. BY: MCOPLAN
 DRAWN BY: MCOPLAN
 DATE: 24JAN03
 SCALE: 1=15
 1192-R08A-182090

DAKTRONICS, INC. BROOKINGS, SD 57006

THE CONCEPTS EXPRESSED AND DETAILS SHOWN ON THIS DRAWING ARE CONFIDENTIAL AND PROPRIETARY. DO NOT REPRODUCE BY ANY MEANS, INCLUDING ELECTRONICALLY WITHOUT THE EXPRESSED WRITTEN CONSENT OF DAKTRONICS, INC. COPYRIGHT 2002 DAKTRONICS, INC.

TI-2010-11/-21

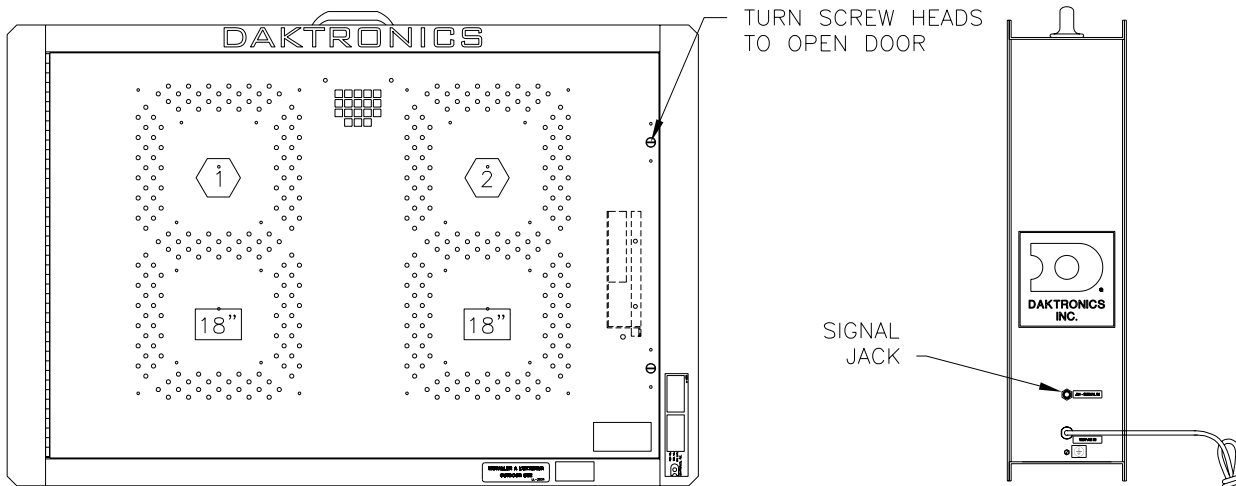

FRONT VIEW

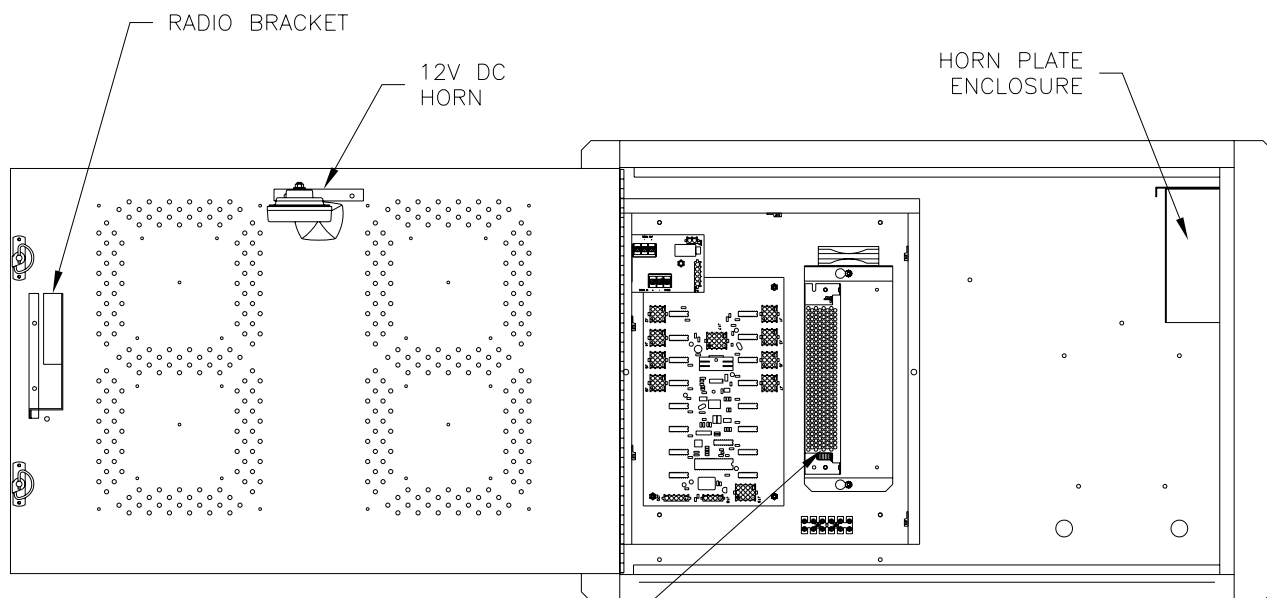

ENCLOSED 8 COLUMN LED DRIVER & POWER & SIGNAL ENCLOSURE. (THE COVER HAS BEEN REMOVED TO SHOWN THE COMPONENT DETAIL).

FRONT VIEW
ACCESS DOOR OPEN

1 = LED DRIVER CONNECTOR WIRED TO THAT DIGIT.

18" = DIGIT SIZE

THE CONCEPTS EXPRESSED AND DETAILS SHOWN ON THIS DRAWING ARE CONFIDENTIAL AND PROPRIETARY. DO NOT REPRODUCE BY ANY MEANS, INCLUDING ELECTRONICALLY WITHOUT THE EXPRESSED WRITTEN CONSENT OF DAKTRONICS, INC. COPYRIGHT 2002 DAKTRONICS, INC.			
DAKTRONICS, INC. BROOKINGS, SD 57006			
PROJ: OUTDOOR LED SCOREBOARDS			
TITLE: COMPONENT LOCATIONS; TI-2010-11/-21, G3			
DES. BY: MCOPLAN		DRAWN BY: MCOPLAN	
		DATE: 24JAN03	
REVISION	APPR. BY:	1192-R08A-182110	
01	SCALE: 1=10		

01	25AUG06	ADDED RADIO BRACKET & UPDATED METAL PARTS	TAJ	
REV.	DATE	DESCRIPTION	BY	APPR.

TI-2015-11/-21

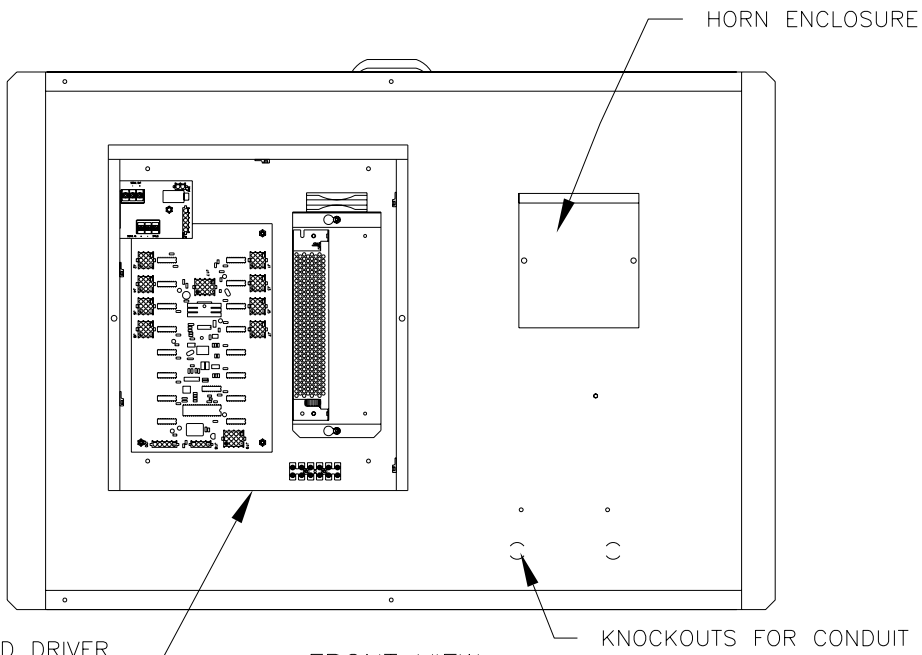

ENCLOSED 8 COLUMN LED DRIVER AND POWER/SIGNAL ENCLOSURE. (THE COVER HAS BEEN REMOVED TO SHOW COMPONENT DETAIL)

FRONT VIEW
DOOR SHOWN OPEN

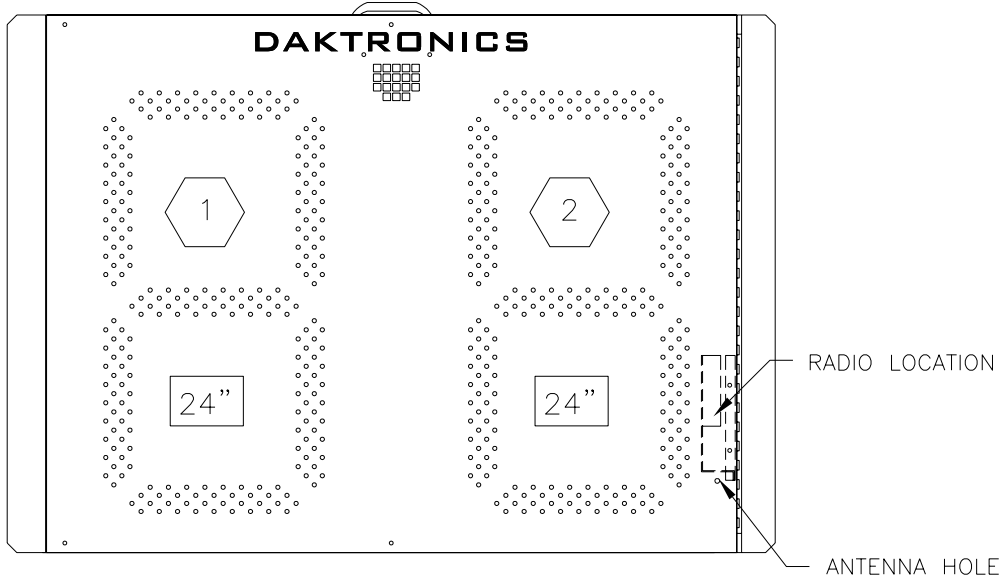

FRONT VIEW
DOOR SHOWN CLOSED

- 1 = DRIVER CONNECTOR WIRED TO THAT DIGIT
- 15" = DIGIT SIZE

THE CONCEPTS EXPRESSED AND DETAILS SHOWN ON THIS DRAWING ARE CONFIDENTIAL AND PROPRIETARY. DO NOT REPRODUCE BY ANY MEANS, INCLUDING ELECTRONICALLY WITHOUT THE EXPRESSED WRITTEN CONSENT OF DAKTRONICS, INC. COPYRIGHT 2002 DAKTRONICS, INC.

DAKTRONICS, INC. BROOKINGS, SD 57006

PROJ: **OUTDOOR LED SCOREBOARDS**

TITLE: **COMPONENT LOCATIONS; TI-2015-11/-21, G3**

DES. BY: **MCOPLAN** DRAWN BY: **MCOPLAN** DATE: **27JAN03**

REVISION	APPR. BY:	1192-R08A-182176
02	SCALE: 1=10	

REV.	DATE	DESCRIPTION	BY	APPR.
02	17 OCT 06	MOVED HORN ASSY LOCATION	AJS	
01	21SEPT06	ADDED RADIO BRACKET	TAJ	

RO-2010-11/-21

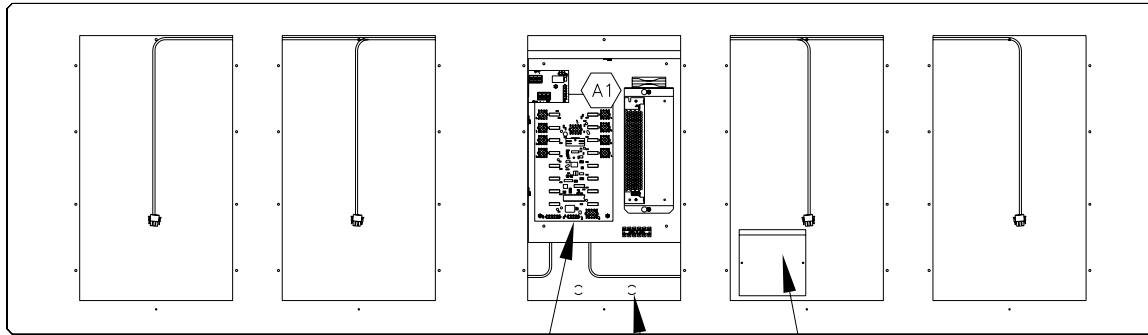

ENCLOSED 8 COLUMN DRIVER AND POWER/SIGNAL ENCLOSURE. (THE COVER HAS BEEN REMOVED TO SHOW COMPONENT DETAIL).

KNOCKOUT FOR 1/2" CONDUIT

HORN (OPTIONAL)

FRONT VIEW

(SHOWN WITH DIGITS REMOVED)

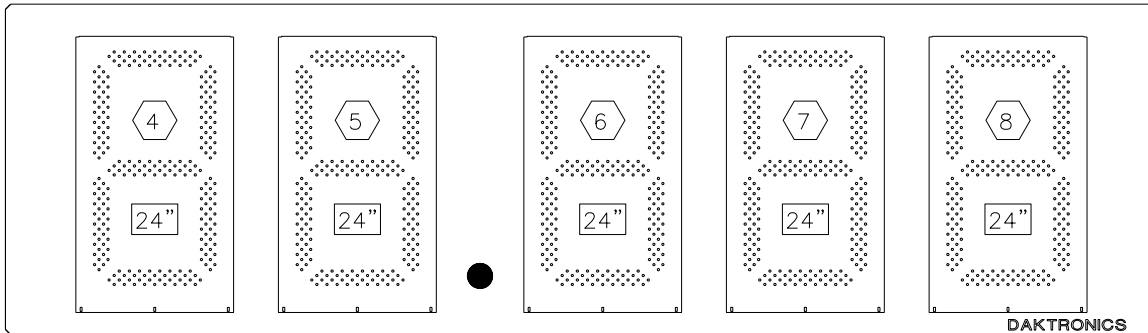

FRONT VIEW

(SHOWN WITH DIGITS INSTALLED)

$\triangle A1$ = LED DRIVER NUMBER

$\triangle 1$ = LED DRIVER CONNECTOR WIRED TO THAT DIGIT.

$\square 24"$ = DIGIT SIZE

HINGED ACCESS DOORS REMOVED TO SHOW THE LED DRIVER AND THE POWER/SIGNAL ENCLOSURE.

THE CONCEPTS EXPRESSED AND DETAILS SHOWN ON THIS DRAWING ARE CONFIDENTIAL AND PROPRIETARY. DO NOT REPRODUCE BY ANY MEANS, INCLUDING ELECTRONICALLY WITHOUT THE EXPRESSED WRITTEN CONSENT OF DAKTRONICS, INC. COPYRIGHT 2002 DAKTRONICS, INC.			
DAKTRONICS, INC. BROOKINGS, SD 57006			
PROJ: RODEO SCOREBOARDS			
TITLE: COMPONENT LOCATIONS; RO-2010-11/-21			
DES. BY: MCOPLAN		DRAWN BY: MCOPLAN	
		DATE: 29JAN03	
REVISION	APPR. BY:	1162-R08A-182293	
	SCALE: 1=18		

REV.	DATE	DESCRIPTION	BY	APPR.

RO-2011-11/-21

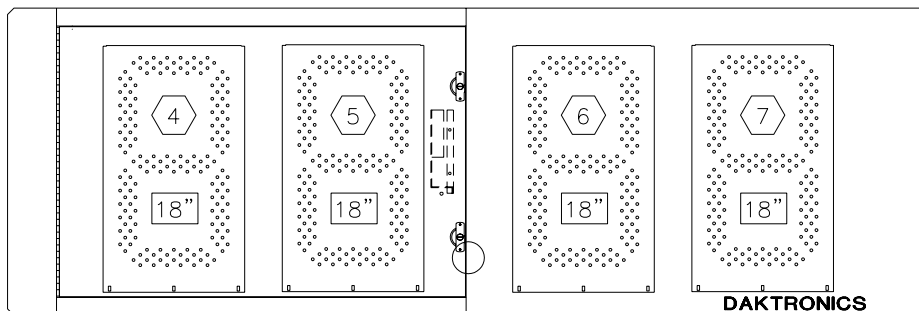

FRONT VIEW

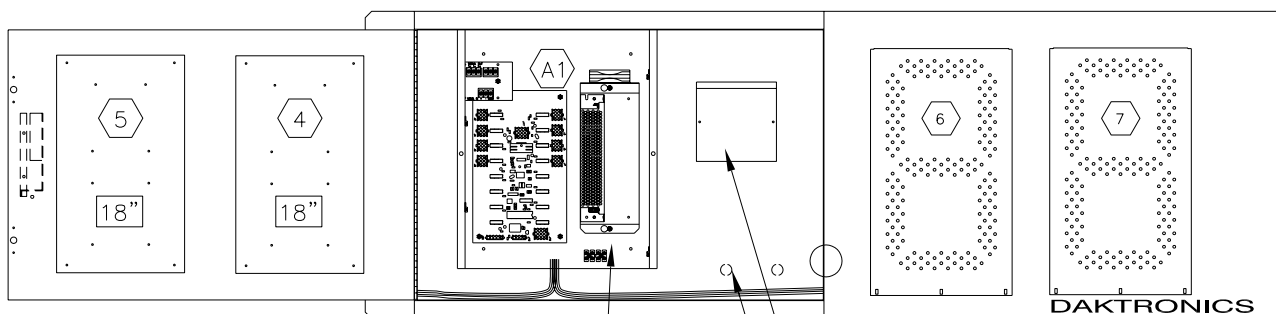

ENCLOSED 8 COLUMN LED DRIVER AND POWER/SIGNAL ENCLOSURE. (THE COVER HAS BEEN REMOVED TO SHOW COMPONENT DETAIL).

HORN (OPTIONAL)

KNOCKOUTS FOR 1/2" CONDUIT

FRONT VIEW

ACCESS DOOR OPEN

- A1 = LED DRIVER NUMBER
- 1 = LED DRIVER CONNECTOR WIRED TO THAT DIGIT.
- 24" = DIGIT SIZE

HINGED ACCESS DOORS REMOVED TO SHOW THE LED DRIVER AND THE POWER/SIGNAL ENCLOSURE.

THE CONCEPTS EXPRESSED AND DETAILS SHOWN ON THIS DRAWING ARE CONFIDENTIAL AND PROPRIETARY. DO NOT REPRODUCE BY ANY MEANS, INCLUDING ELECTRONICALLY WITHOUT THE EXPRESSED WRITTEN CONSENT OF DAKTRONICS, INC. COPYRIGHT 2002 DAKTRONICS, INC.

DAKTRONICS, INC. BROOKINGS, SD 57006

PROJ: OUTDOOR RODEO SCOREBOARDS

TITLE: COMPONENT LOCATIONS; RO-2011-11/-21, G3

DES. BY: MCOPLAN

DRAWN BY: MCOPLAN

DATE: 29JAN03

01	17 OCT 07	CHANGED LOCATION OF HINGE ON ACCESS DOOR	KDD	
REV.	DATE	DESCRIPTION	BY	APPR.

REVISION
01

APPR. BY:
SCALE: 1=15

1162-R08A-182296

FB-824-11/-21

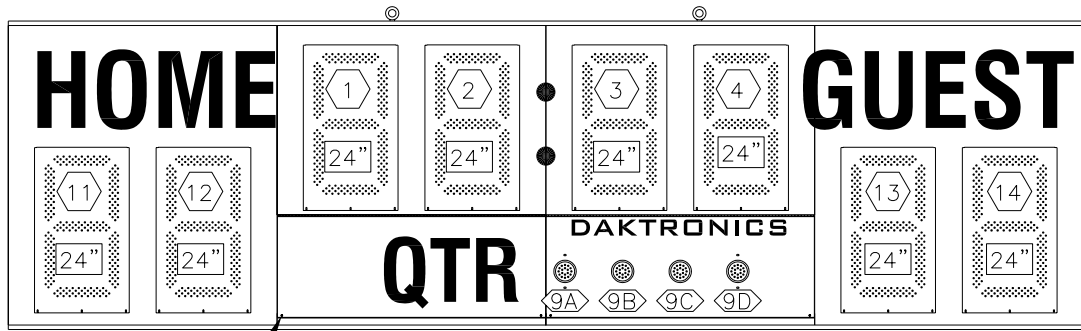

REMOVE SCREWS TO ACCESS LED DRIVER & ENTRANCE

FRONT VIEW
(SHOWN WITH DOORS CLOSED)

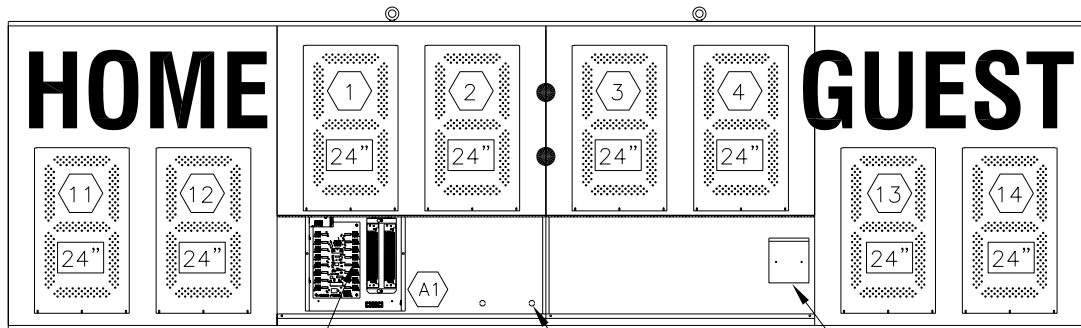



ENCLOSED 16 COLUMN DRIVER AND POWER/SIGNAL ENCLOSURE. (THE COVER HAS BEEN REMOVED TO SHOW COMPONENT DETAIL).

KNOCKOUT FOR 1/2" CONDUIT

HORN (OPTIONAL)

FRONT VIEW
(SHOWN WITH DOORS OPEN)

-  = LED DRIVER CONNECTOR WIRED TO THAT DIGIT.
-  = LED DRIVER CONNECTOR AND SEGMENT (PIN) NO. WIRED TO THAT INDICATOR
-  = DIGIT SIZE

HINGED ACCESS DOORS REMOVED TO SHOW THE LED DRIVER AND THE POWER/SIGNAL ENCLOSURE.

THE CONCEPTS EXPRESSED AND DETAILS SHOWN ON THIS DRAWING ARE CONFIDENTIAL AND PROPRIETARY. DO NOT REPRODUCE BY ANY MEANS, INCLUDING ELECTRONICALLY WITHOUT THE EXPRESSED WRITTEN CONSENT OF DAKTRONICS, INC. COPYRIGHT 2002 DAKTRONICS, INC.

DAKTRONICS, INC. BROOKINGS, SD 57006

PROJ: OUTDOOR LED SCOREBOARDS

TITLE: COMPONENT LOCATIONS; FB-824-11/-21, G3

DES. BY: MCOPLAN

DRAWN BY: MCOPLAN

DATE: 03FEB03

REVISION

APPR. BY:

SCALE: 1=30

1192-R08A-182543

REV.	DATE	DESCRIPTION	BY	APPR.

TI-2003-11/-21

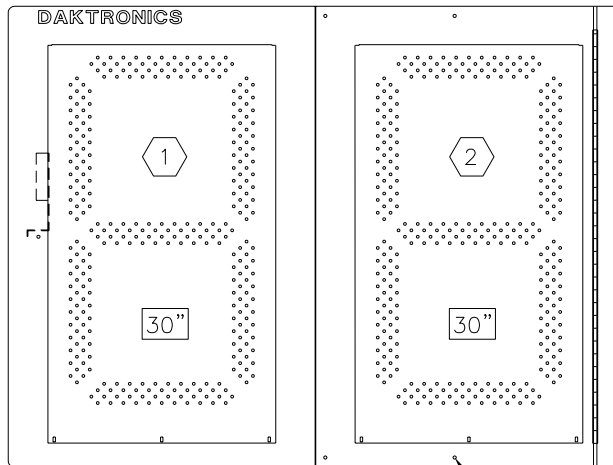

FRONT VIEW

REMOVE SCREWS TO ACCESS LED DRIVER & ENTRANCE

ENCLOSED 8 COLUMN LED DRIVER AND POWER/SIGNAL ENCLOSURE. (THE DOOR IS OPEN AND THE ENCLOSURE COVER HAS BEEN REMOVED TO SHOW COMPONENT DETAIL.)

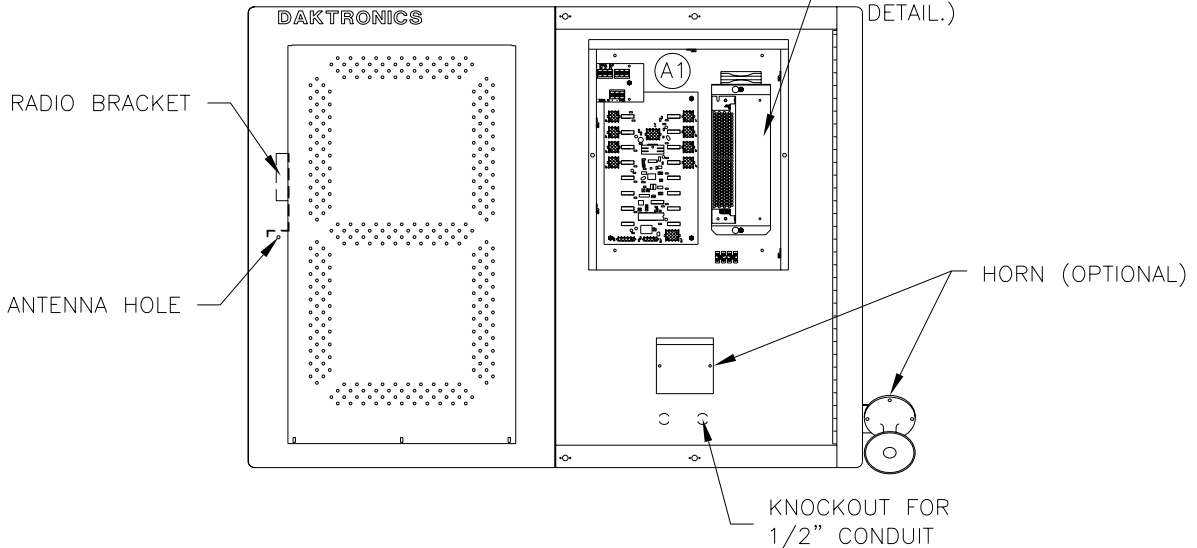

FRONT VIEW
ACCESS DOOR OPEN

1 = LED DRIVER CONNECTOR WIRED TO THAT DIGIT.

30" = DIGIT SIZE

THE CONCEPTS EXPRESSED AND DETAILS SHOWN ON THIS DRAWING ARE CONFIDENTIAL AND PROPRIETARY. DO NOT REPRODUCE BY ANY MEANS, INCLUDING ELECTRONICALLY WITHOUT THE EXPRESSED WRITTEN CONSENT OF DAKTRONICS, INC. COPYRIGHT 2003 DAKTRONICS, INC.

DAKTRONICS, INC. BROOKINGS, SD 57006

PROJ: OUTDOOR LED SCOREBOARDS

TITLE: COMPONENT LOCATIONS; TI-2003-11/-21, G3

DES. BY: MCOPLAN

DRAWN BY: MCOPLAN

DATE: 05FEB03

REV.	DATE	DESCRIPTION	BY	APPR.
01	21SEPT06	ADDED RADIO BRACKET	TAJ	

REVISION	APPR. BY:
01	

SCALE: 1=15

1192-R08A-182702

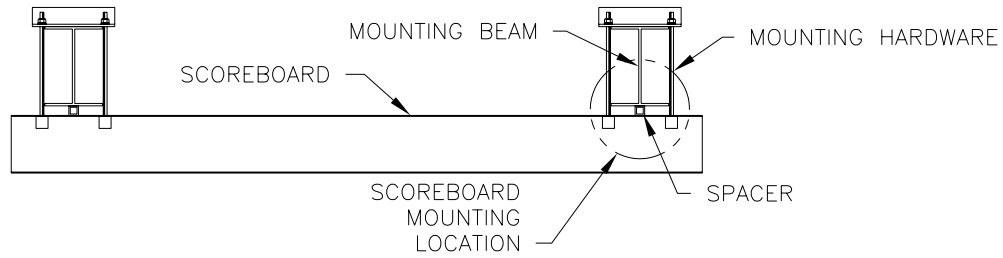

TOP VIEW

SPACERS TO BE PROVIDED BY THE CUSTOMER

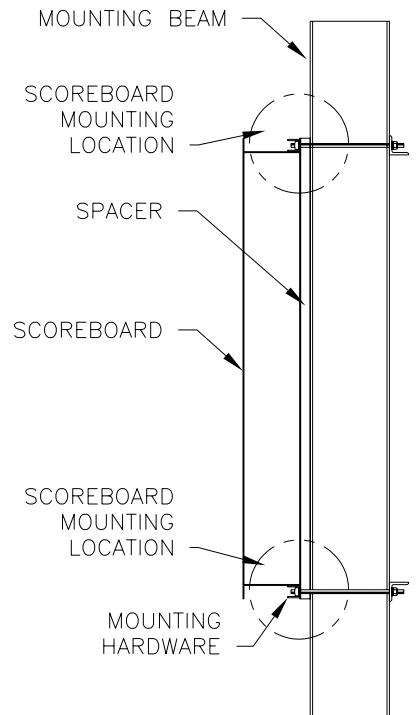
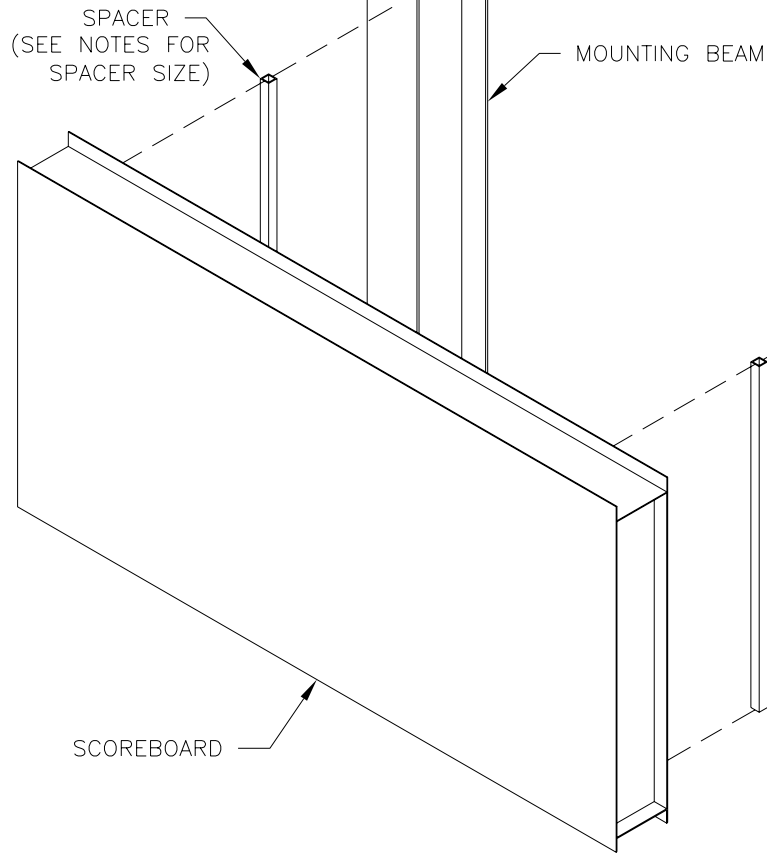

SIDE VIEW

NOTES:

- SPACER SIZE CANNOT EXCEED THE HEIGHT OF THE SCOREBOARD BUT DOES NOT HAVE TO BE THE SAME HEIGHT AS THE SCOREBOARD. SMALLER LENGTHS OF SPACER MATERIAL MAY BE USED AS LONG AS THEY ARE USED AT THE TOP AND BOTTOM SCOREBOARD MOUNTING LOCATIONS. SPACERS SHOWN ABOVE ARE 1"X1". TYPICALLY, THE SPACER DEPTH WILL BE DETERMINED BY THE DIFFERENCE IN DEPTH OF THE SCOREBOARD AND THE AD PANEL (AD PANEL DEPTH - SCOREBOARD DEPTH = SPACER DEPTH).
- THE SPACERS ARE TO BE PROVIDED BY THE CUSTOMER.
- THE SPACERS ARE TO BE PLACED BETWEEN THE SCOREBOARD AND THE MOUNTING POLE.
- THE SPACERS DO NOT NEED TO BE MECHANICALLY ATTACHED TO THE SCOREBOARD OR THE MOUNTING BEAM. THEY WILL BE COMPRESSED BETWEEN THE SCOREBOARD AND THE MOUNTING BEAM WHEN THE SCOREBOARD IS MOUNTED.
- REFER TO THE SCOREBOARD MANUAL FOR THE SCOREBOARD MOUNTING HARDWARE AND OTHER SCOREBOARD MOUNTING DETAILS.

THE CONCEPTS EXPRESSED AND DETAILS SHOWN ON THIS DRAWING ARE CONFIDENTIAL AND PROPRIETARY. DO NOT REPRODUCE BY ANY MEANS, INCLUDING ELECTRONICALLY WITHOUT THE EXPRESSED WRITTEN CONSENT OF DAKTRONICS, INC. COPYRIGHT 2003 DAKTRONICS, INC.	
DAKTRONICS, INC. BROOKINGS, SD 57006	
PROJ: OUTDOOR SCOREBOARDS	
TITLE: SCOREBOARD MTG; SCOREBOARD WITH SPACERS	
DES. BY: MCOPLAN	DRAWN BY: MCOPLAN
DATE: 07FEB03	
REVISION	APPR. BY: _____
	SCALE: 1=20
1192-R08A-182909	

REV.	DATE	DESCRIPTION	BY	APPR.

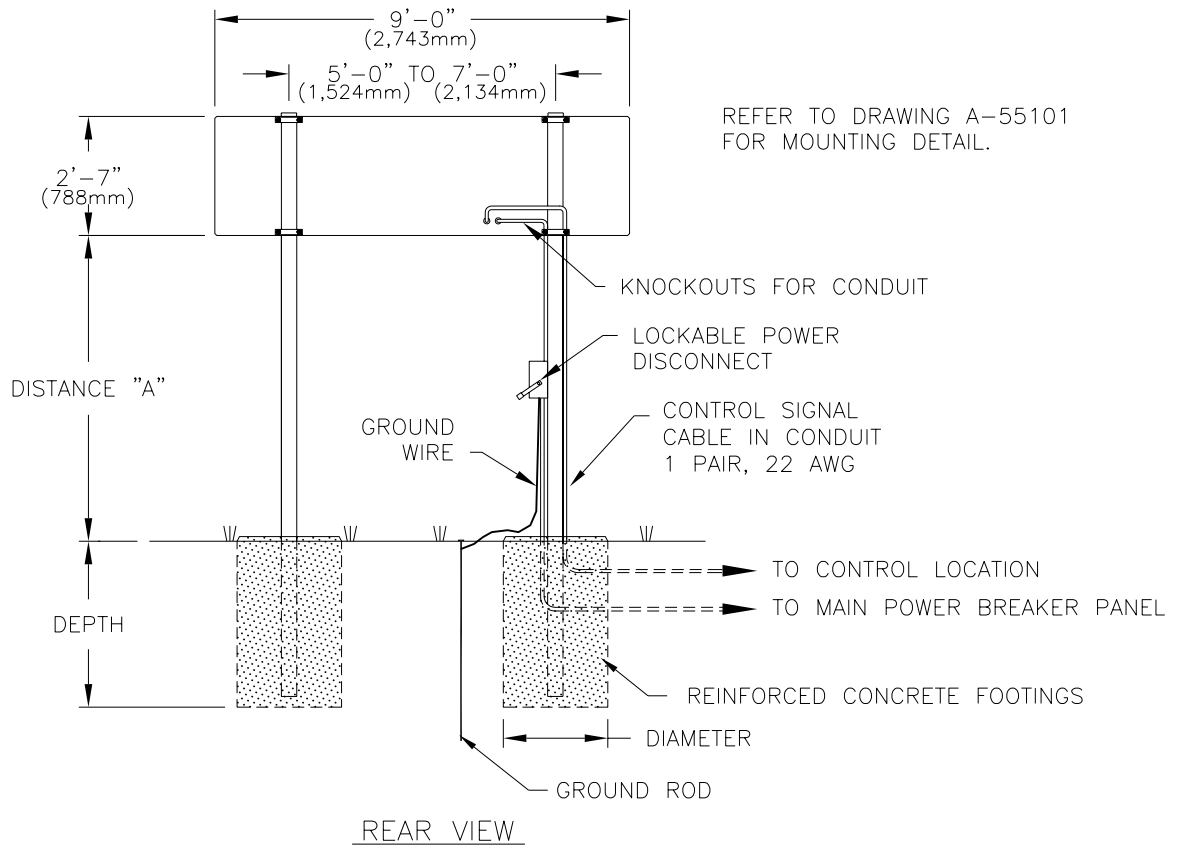

MODELS RO-2010					
DISTANCE "A" (SEE FIGURE)	TOTAL DISPLAY SIZE		DESIGN WIND VELOCITY		
			70 MPH	80 MPH	100 MPH
10'-0"	12'-7" x 9'-0"	BEAM FOOTING	W6X9 2.0 X 4.0	W6X9 2.0 X 4.2	W10X12 2.0 X 5.0
12'-0"	14'-7" x 9'-0"	BEAM FOOTING	W10X12 2.0 X 4.1	W10X12 2.0 X 4.5	W10X15 2.0 X 5.3
14'-0"	16'-7" x 9'-0"	BEAM FOOTING	W10X12 2.0 X 4.4	W10X15 2.0 X 4.8	W6X15 2.0 X 5.7

FOOTING = DIAMETER X DEPTH

DESIGN BASED ON UBC BUILDING CODE.
BEAMS ARE ASSUMED TO BE A992 (50ksi) STEEL.

FOOTING DIMENSIONS ARE SUGGESTIONS ONLY, PROVIDED TO ASSIST WITH ESTIMATING INSTALLATION COSTS AND ARE NOT INTENDED FOR CONSTRUCTION PURPOSES.

FOOTING DIMENSIONS ARE BASED ON ASSUMED UBC SOIL CLASS 4 (LATERAL BEARING 150psf/ft x 2).

ACTUAL FOOTING DEPTH AND DIAMETER FOR A PARTICULAR INSTALLATION MUST BE DETERMINED BY A QUALIFIED STRUCTURAL ENGINEER, USING DATA FROM A SOIL SAMPLE TEST AT THE SITE.

DAKTRONICS, INC. IS NOT RESPONSIBLE FOR STRUCTURES DESIGNED AND INSTALLED BY OTHERS.

WIND DESIGN:
EXPOSURE C
I = 1.0
Cq = 1.4

THE CONCEPTS EXPRESSED AND DETAILS SHOWN ON THIS DRAWING ARE CONFIDENTIAL AND PROPRIETARY. DO NOT REPRODUCE BY ANY MEANS, INCLUDING ELECTRONICALLY WITHOUT THE EXPRESSED WRITTEN CONSENT OF DAKTRONICS, INC. COPYRIGHT 2003 DAKTRONICS, INC.

REV.	DATE	DESCRIPTION	BY	APPR.
03	25 OCT 07	ADDED MILLIMETERS DIMENSIONS	KDD	
02	28MAY03	REMOVED MODEL CT-2002	MCOPL	
01	27MAY03	ADDED MODEL CT-2002	MCOPL	

DAKTRONICS, INC. BROOKINGS, SD 57006	
PROJ: OUTDOOR SCOREBOARDS	
TITLE: INSTALLATION SPECS; RO-2010	
DES. BY: MCOPLAN	DRAWN BY: MCOPLAN DATE: 19MAR03
REVISION	APPR. BY:
03	SCALE: 1=50
1091-E10A-185216	

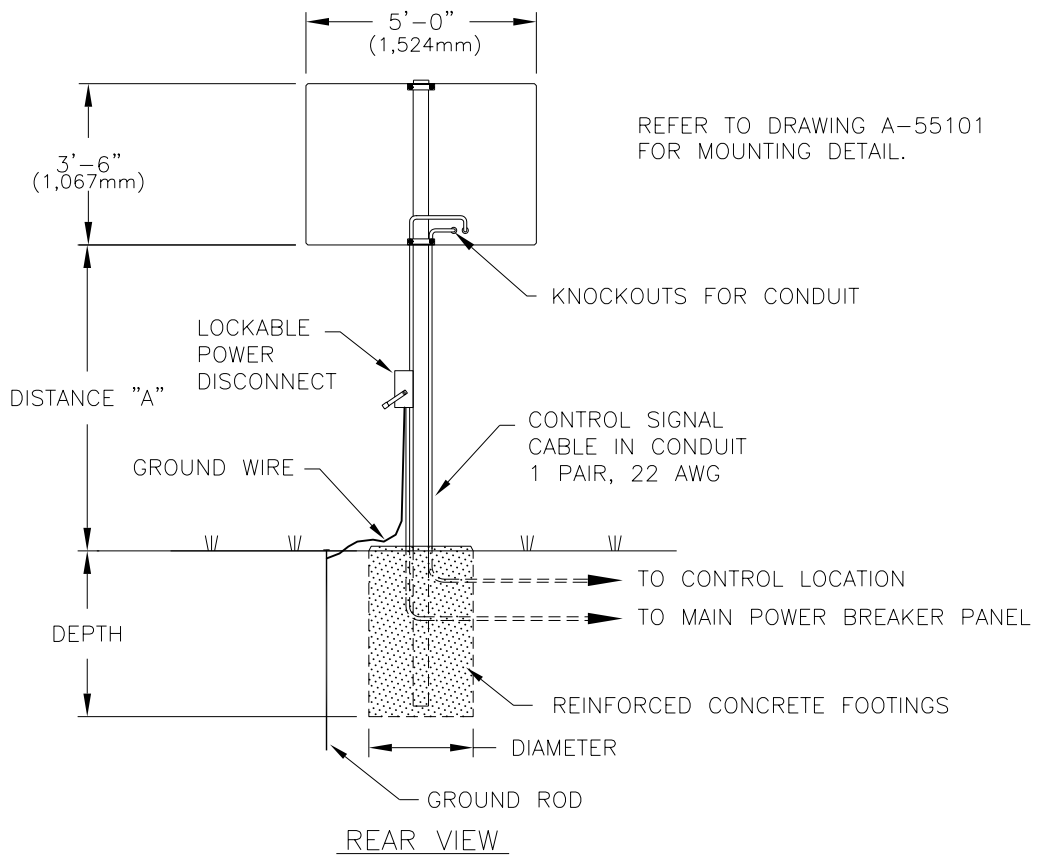

MODEL TI-2012					
DISTANCE "A" (SEE FIGURE)	TOTAL DISPLAY SIZE		DESIGN WIND VELOCITY		
			70 MPH	80 MPH	100 MPH
10'-0"	13'-6" x 5'-0"	BEAM FOOTING	TS4x4x3/16 2.0' x 4.4'	TS4x4x3/16 2.0' x 4.9'	TS4x4x1/4 2.0' x 5.8'
12'-0"	15'-6" x 5'-0"	BEAM FOOTING	TS4x4x3/16 2.0' x 4.7'	TS4x4x3/16 2.0' x 5.2'	TS4x4x1/4 2.0' x 6.2'
14'-0"	17'-6" x 5'-0"	BEAM FOOTING	TS4x4x3/16 2.0' x 5.0'	TS4x4x1/4 2.0' x 5.5'	TS5x5x1/4 2.0' x 6.6'

FOOTING = DIAMETER X DEPTH

DESIGN BASED ON UBC 97 BUILDING CODE.
BEAM IS ASSUMED TO BE A500-B STEEL (46ksi).

FOOTING DIMENSIONS ARE SUGGESTIONS ONLY, PROVIDED TO ASSIST WITH ESTIMATING INSTALLATION COSTS AND ARE NOT INTENDED FOR CONSTRUCTION PURPOSES.

FOOTING DIMENSIONS ARE BASED ON ASSUMED UBC SOIL CLASS 4 (LATERAL BEARING 150psf/ft x 2)

ACTUAL FOOTING DEPTH AND DIAMETER FOR A PARTICULAR INSTALLATION MUST BE DETERMINED BY A QUALIFIED STRUCTURAL ENGINEER, USING DATA FROM A SOIL SAMPLE TEST AT THE SITE.

DAKTRONICS, INC. IS NOT RESPONSIBLE FOR STRUCTURES DESIGNED AND INSTALLED BY OTHERS.

WIND DESIGN:
EXPOSURE C
I = 1.0
C_q = 1.4

THE CONCEPTS EXPRESSED AND DETAILS SHOWN ON THIS DRAWING ARE CONFIDENTIAL AND PROPRIETARY. DO NOT REPRODUCE BY ANY MEANS, INCLUDING ELECTRONICALLY WITHOUT THE EXPRESSED WRITTEN CONSENT OF DAKTRONICS, INC. COPYRIGHT 2003 DAKTRONICS, INC.

DAKTRONICS, INC. BROOKINGS, SD 57006

PROJ: OUTDOOR SCOREBOARDS

TITLE: INSTALLATION SPECIFICATIONS; TI-2012

DES. BY: RNEYENS

DRAWN BY: MCOPLAN

DATE: 26MAR03

REV.	DATE	DESCRIPTION	BY	APPR.
01	25 OCT 07	ADDED MILLIMETERS DIMENSIONS	KDD	

REVISION	APPR. BY:
01	SCALE: 1=50

1091-E10A-185698

REV.	DATE	DESCRIPTION	BY	APPR.

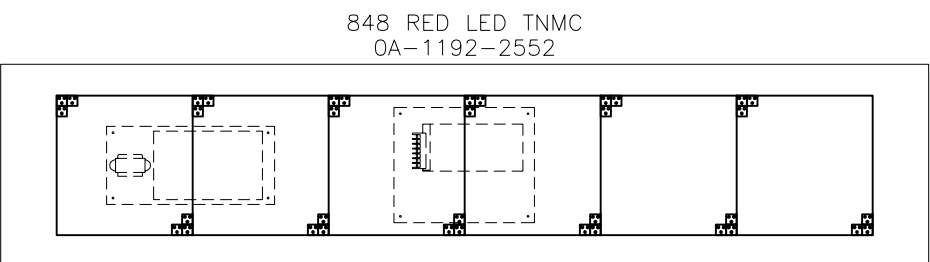
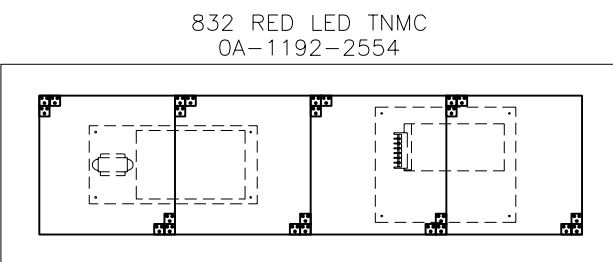
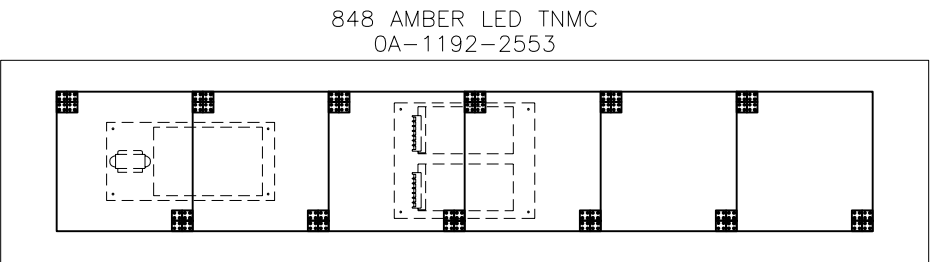
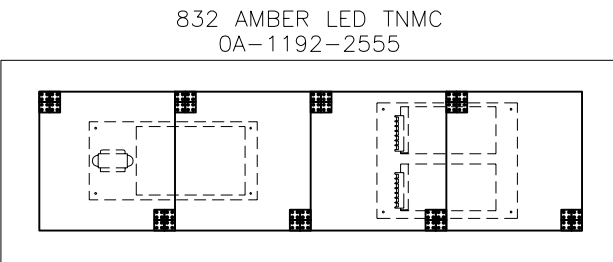

THE CONCEPTS EXPRESSED AND DETAILS SHOWN ON THIS DRAWING ARE CONFIDENTIAL AND PROPRIETARY. DO NOT REPRODUCE BY ANY MEANS, INCLUDING ELECTRONICALLY WITHOUT THE EXPRESSED WRITTEN CONSENT OF DAKTRONICS, INC. COPYRIGHT 2003 DAKTRONICS, INC.

PROJ: OUTDOOR LED SCOREBOARDS
DAKTRONICS, INC. BROOKINGS, SD 57006

REVISION

DES. BY: MCOPLAN
DRAWN BY: MCOPLAN
DATE: 01MAY03

APPR. BY: 1192-R08A-187987

SCALE: 1=15

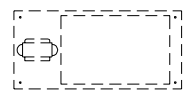

TNMC CONTROLLER
0A-1192-2549
USED IN RED & AMBER LED TNMCs

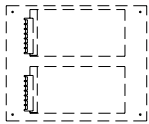

DOUBLE POWER SUPPLY ASSEMBLY
0A-1192-2551
USED IN AMBER LED TNMCs

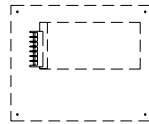

SINGLE POWER SUPPLY ASSEMBLY
0A-1192-2550
USED IN RED LED TNMCs

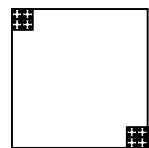

AMBER LED TNMC MODULE
0A-1208-3005
USED IN AMBER LED TNMCs

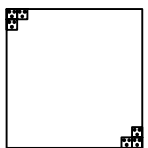

RED LED TNMC MODULE
0A-1208-3006
USED IN RED LED TNMCs

MS-2006-11/-21

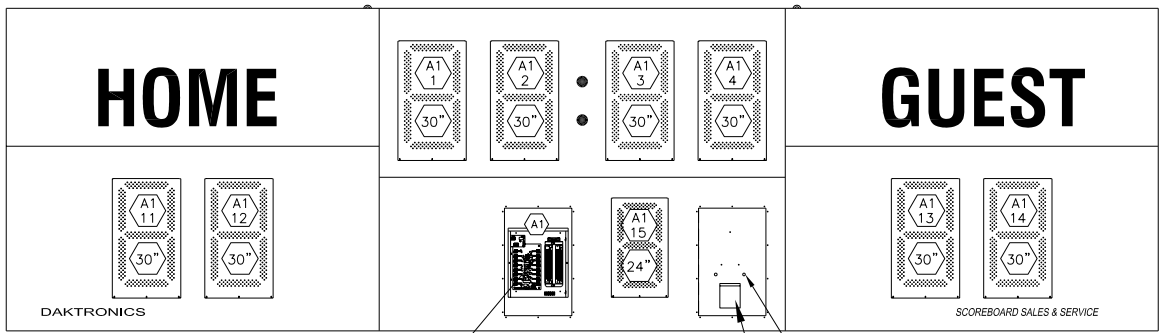

ENCLOSED 16 COLUMN LED DRIVER AND POWER AND SIGNAL ENCLOSURE. (THE COVER IS REMOVED TO SHOW THE LED DRIVER.)

FRONT VIEW

KNOCKOUT FOR 1/2" CONDUIT
HORN (OPTIONAL)

MS-2006-11/-21 W/ TNMC

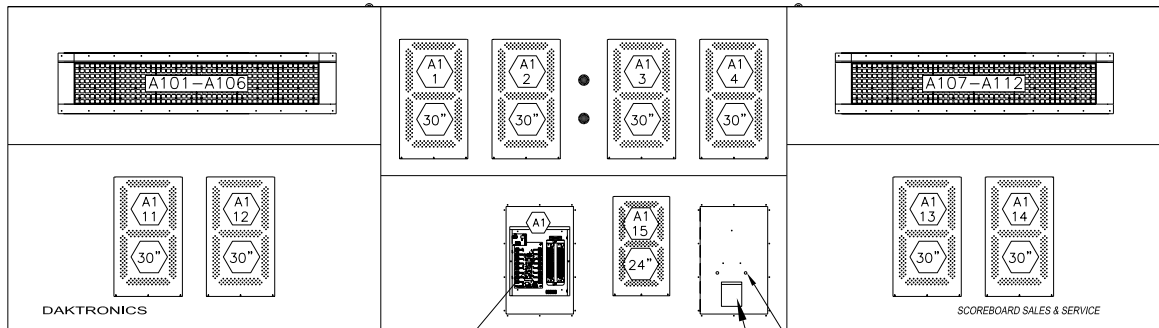

ENCLOSED 16 COLUMN LED DRIVER AND POWER AND SIGNAL ENCLOSURE. (THE COVER IS REMOVED TO SHOW THE LED DRIVER.)

FRONT VIEW

KNOCKOUT FOR 1/2" CONDUIT
HORN (OPTIONAL)

⬡ = LED DRIVER CONNECTOR WIRED TO THAT DIGIT.

18" = DIGIT SIZE

HINGED ACCESS DOORS REMOVED TO SHOW THE LED DRIVER AND POWER AND SIGNAL ENCLOSURE.

THE CONCEPTS EXPRESSED AND DETAILS SHOWN ON THIS DRAWING ARE CONFIDENTIAL AND PROPRIETARY. DO NOT REPRODUCE BY ANY MEANS, INCLUDING ELECTRONICALLY WITHOUT THE EXPRESSED WRITTEN CONSENT OF DAKTRONICS, INC. COPYRIGHT 2003 DAKTRONICS, INC.

DAKTRONICS, INC. BROOKINGS, SD 57006

PROJ: OUTDOOR LED SCOREBOARDS
TITLE: COMPONENT LOCATIONS; MS-2006-11/-21, G3
DES. BY: MCOPLAN DRAWN BY: MCOPLAN DATE: 28MAY03

REVISION	APPR. BY:	1192-R08A-189213
02	SCALE: 1=50	

02	30 AUG 07	REMOVED LEFT DRIVER DOOR MOVED DRIVER TO THE RIGHT	KDD	
01	11 OCT 05	UPDATED DRIVER LOCATION FOR MS-2006-11/-21 TO MATCH ACTUAL BOARD.	CAC	
REV.	DATE	DESCRIPTION	BY	APPR.

MS-2003-11/-21

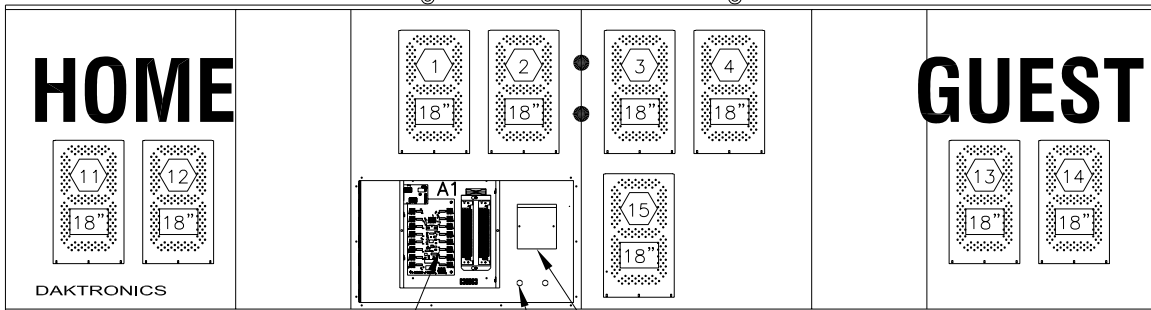

ENCLOSED 16 COLUMN LED DRIVER. (THE COVER IS REMOVED TO SHOW THE LED DRIVER.)

HORN (OPTIONAL)

KNOCKOUT FOR 1/2" CONDUIT

FRONT VIEW

MS-2003-11/-21 W/ TNMC

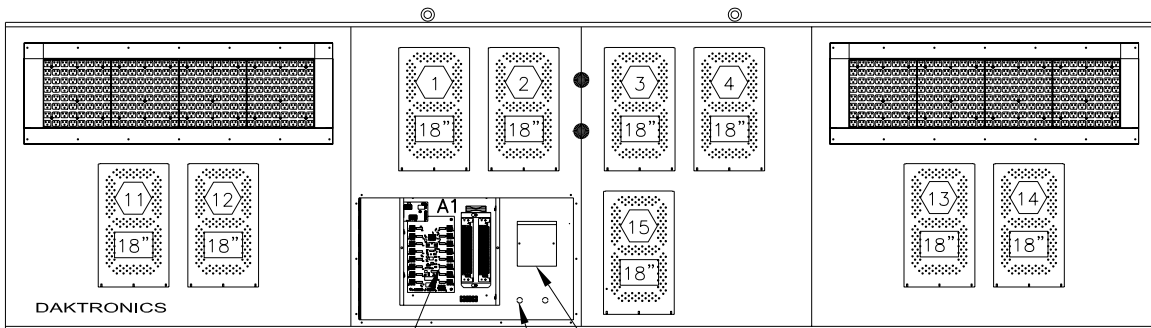

ENCLOSED 16 COLUMN LED DRIVER. (THE COVER IS REMOVED TO SHOW THE LED DRIVER.)

HORN (OPTIONAL)

KNOCKOUT FOR 1/2" CONDUIT

FRONT VIEW

① = LED DRIVER CONNECTOR WIRED TO THAT DIGIT.

24" = DIGIT SIZE

HINGED ACCESS DOORS REMOVED TO SHOW THE LED DRIVER AND POWER AND SIGNAL ENCLOSURE.

THE CONCEPTS EXPRESSED AND DETAILS SHOWN ON THIS DRAWING ARE CONFIDENTIAL AND PROPRIETARY. DO NOT REPRODUCE BY ANY MEANS, INCLUDING ELECTRONICALLY WITHOUT THE EXPRESSED WRITTEN CONSENT OF DAKTRONICS, INC. COPYRIGHT 2003 DAKTRONICS, INC.			
DAKTRONICS, INC. BROOKINGS, SD 57006			
PROJ: OUTDOOR LED SCOREBOARDS			
TITLE: COMPONENT LOCATIONS; MS-2003-11/-21, G3			
DES. BY: MCOPLAN		DRAWN BY: MCOPLAN	
		DATE: 05JUN03	
REVISION	APPR. BY:	1192-R08A-189593	
01	SCALE: 1=30		

01	14 NOV 06	ELIMINATED 2ND ACCESS DOOR MOVED HORN LOCATION	AJS	
REV.	DATE	DESCRIPTION	BY	APPR.

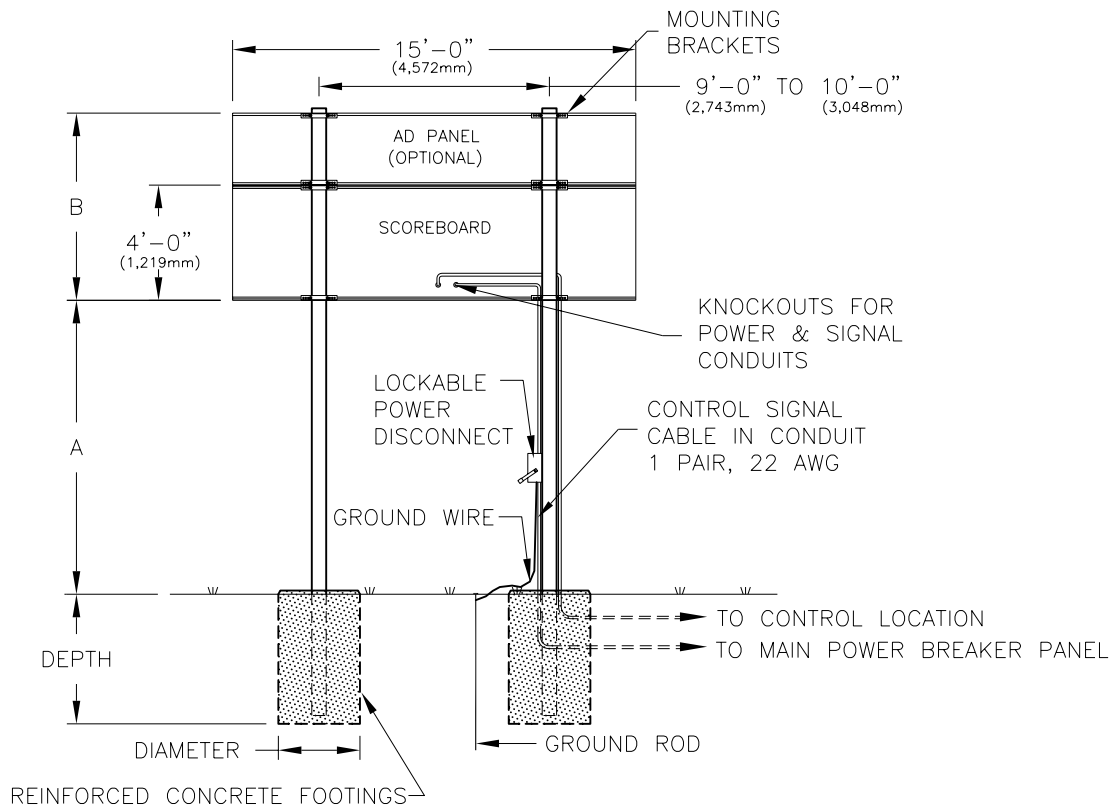

REAR VIEW

MS-2003

ELECTRICAL

POWER CABLE MUST HAVE A SEPARATE GROUND CONDUCTOR. SCOREBOARD MUST BE CONNECTED TO A GROUND ROD AT SCOREBOARD LOCATION.

FOOTING DIMENSIONS ARE SUGGESTIONS ONLY, PROVIDED TO ASSIST WITH ESTIMATING INSTALLATION COSTS, AND ARE NOT INTENDED FOR CONSTRUCTION PURPOSES.

COLUMNS AND FOOTINGS MUST BE DESIGNED BY A STATE LICENCED ENGINEER. DAKTRONICS DOES NOT ASSUME ANY LIABILITY FOR ANY INSTALLATIONS DERIVED FROM THIS INFORMATION OR DESIGNED AND INSTALLED BY OTHERS.

A NOTE ABOUT BEAM NOMENCLATURE:

For a typical beam, W12X30 for example, "W" stands for "Wide-Flange Beam". The first number (12) is the approximate front to rear dimension of the beam in inches. The second number (30) is the weight per foot in pounds. This numbering is standard in the steel industry. Widths vary from 4 to 8 inches in this chart.

MS-2003						
VERTICAL DISTANCE (A)	AD PANEL HEIGHT	COMBINED HEIGHT (B)		DESIGN WIND VELOCITY		
				70 MPH	80 MPH	100 MPH
10 FT	NONE	4'-0"	BEAM	W10X12	W10X15	W6X15
			FOOTING	2.5X4.8	2.5X5.3	2.5X6.3
	2 FT	6'-0"	BEAM	W6X15	W6X15	W10X22
			FOOTING	2.5X5.6	2.5X6.2	2.5X7.3
	4 FT	8'-0"	BEAM	W8X18	W10X22	W8X24
			FOOTING	2.5X6.4	2.5X7.0	2.5X8.3
12 FT	NONE	4'-0"	BEAM	W10X15	W6X15	W8X18
			FOOTING	2.5X5.1	2.5X5.6	2.5X6.6
	2 FT	6'-0"	BEAM	W8X18	W6X20	W8X24
			FOOTING	2.5X5.9	2.5X6.6	2.5X7.7
	4 FT	8'-0"	BEAM	W8X24	W8X24	W8X28
			FOOTING	2.5X6.6	2.5X7.3	2.5X8.6
14 FT	NONE	4'-0"	BEAM	W6X15	W8X18	W10X22
			FOOTING	2.5X5.5	2.5X6.0	2.5X7.1
	2 FT	6'-0"	BEAM	W6X20	W8X24	W12X26
			FOOTING	2.5X6.2	2.5X6.8	2.5X8.1
	4 FT	8'-0"	BEAM	W8X24	W12X26	W10X33
			FOOTING	2.5X7.0	2.5X7.7	2.5X9.1

FOOTING = DIAMETER X DEPTH

*UBC 97 CODE, EXP C, IMPORTANCE = 1.0 SOIL CLASS 4 (150pcf/ft X 2 LATERAL SOIL BEARING)

THE CONCEPTS EXPRESSED AND DETAILS SHOWN ON THIS DRAWING ARE CONFIDENTIAL AND PROPRIETARY. DO NOT REPRODUCE BY ANY MEANS, INCLUDING ELECTRONICALLY WITHOUT THE EXPRESSED WRITTEN CONSENT OF DAKTRONICS, INC. COPYRIGHT 2003 DAKTRONICS, INC.			
DAKTRONICS, INC. BROOKINGS, SD 57006			
PROJ: OUTDOOR LED SCOREBOARDS			
TITLE: INSTALLATION SPECIFICATIONS; MS-2003			
DES. BY: RNEYEN		DRAWN BY: MCOPLAN	
DATE: 20AUG03			
REVISION	APPR. BY:	1192-R08A-191730	
01	SCALE: 1=80		

01	25 OCT 07	ADDED MILLIMETERS DIMENSIONS	KDD	
REV.	DATE	DESCRIPTION	BY	APPR.

MS-2011-11/-21

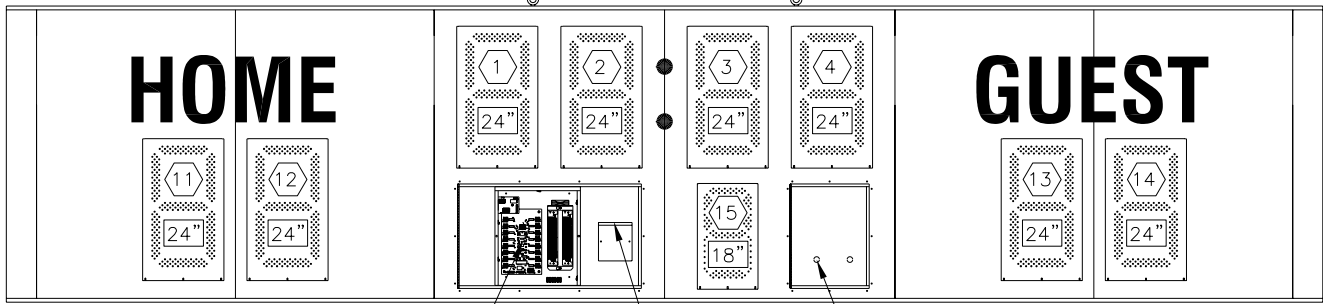

ENCLOSED 16 COLUMN LED DRIVER. (THE COVER IS REMOVED TO SHOW THE LED DRIVER.)

HORN (OPTIONAL)

KNOCKOUT FOR 1/2" CONDUIT

FRONT VIEW

(SHOWN WITH DOORS OPEN)

MS-2011-11/-21 W/ TNMC

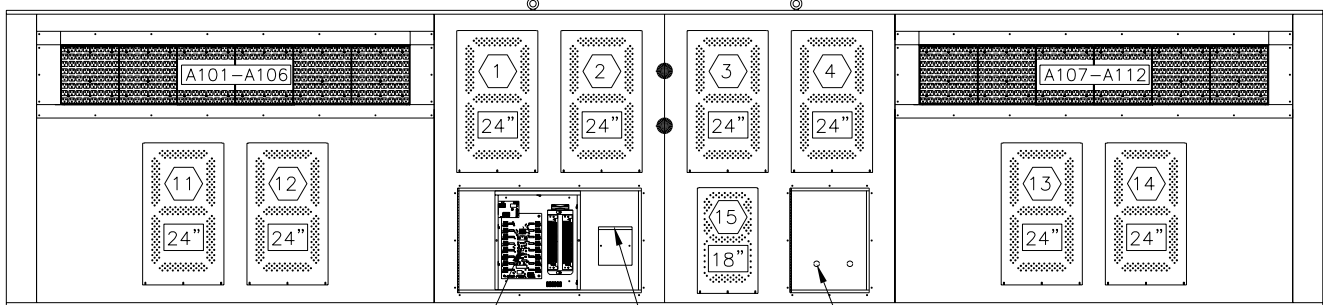

ENCLOSED 16 COLUMN LED DRIVER. (THE COVER IS REMOVED TO SHOW THE LED DRIVER.)

HORN (OPTIONAL)

KNOCKOUT FOR 1/2" CONDUIT

FRONT VIEW

(SHOWN WITH DOORS OPEN)

1 = LED DRIVER CONNECTOR WIRED TO THAT DIGIT.

24" = DIGIT SIZE

HINGED ACCESS DOORS REMOVED TO SHOW THE LED DRIVER AND POWER AND SIGNAL ENCLOSURE.

THE CONCEPTS EXPRESSED AND DETAILS SHOWN ON THIS DRAWING ARE CONFIDENTIAL AND PROPRIETARY. DO NOT REPRODUCE BY ANY MEANS, INCLUDING ELECTRONICALLY WITHOUT THE EXPRESSED WRITTEN CONSENT OF DAKTRONICS, INC. COPYRIGHT 2003 DAKTRONICS, INC.

DAKTRONICS, INC. BROOKINGS, SD 57006

PROJ: OUTDOOR LED SCOREBOARDS

TITLE: COMPONENT LOCATIONS; MS-2011-11/-21, G3

DES. BY: MCOPLAN

DRAWN BY: MCOPLAN

DATE: 01AUG03

REVISION

APPR. BY:

SCALE: 1=35

1192-R08A-193823

REV.	DATE	DESCRIPTION	BY	APPR.
00				

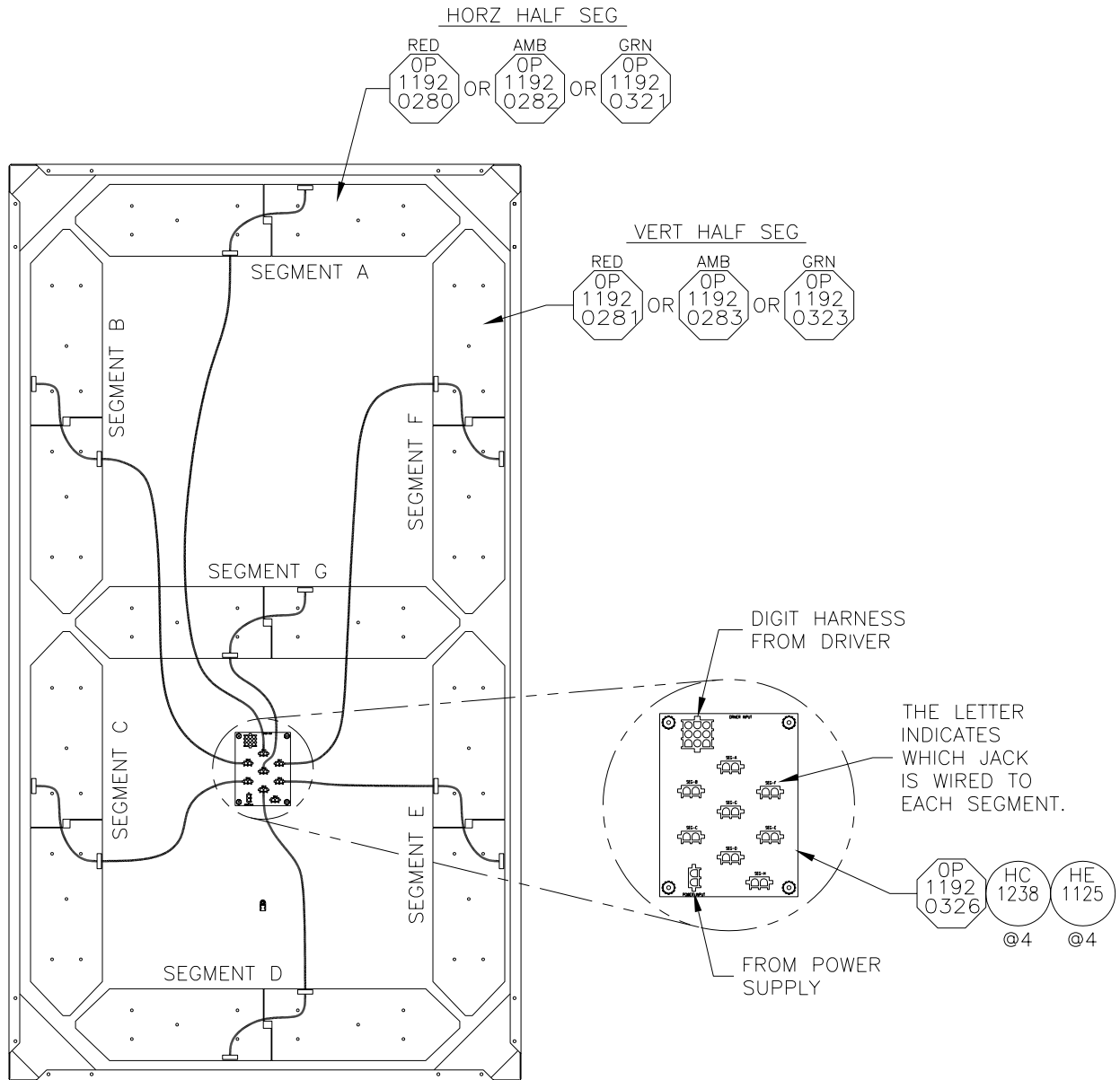

REAR VIEW

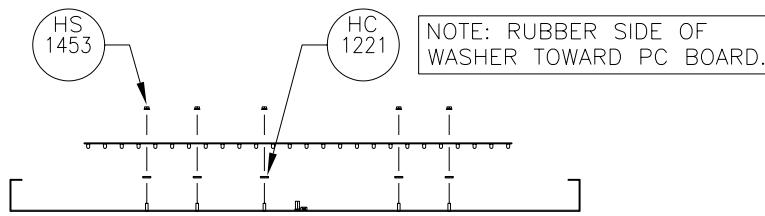

DIGIT SEGMENTS

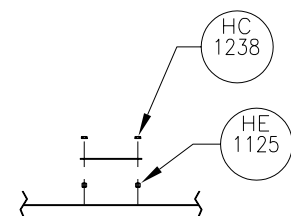

BREAKOUT BOARD

THE CONCEPTS EXPRESSED AND DETAILS SHOWN ON THIS DRAWING ARE CONFIDENTIAL AND PROPRIETARY. DO NOT REPRODUCE BY ANY MEANS, INCLUDING ELECTRONICALLY WITHOUT THE EXPRESSED WRITTEN CONSENT OF DAKTRONICS, INC. COPYRIGHT 2003 DAKTRONICS, INC.			
DAKTRONICS, INC. BROOKINGS, SD 57006			
PROJ:			
TITLE: FA, 60" DIGIT			
DES. BY:		DRAWN BY: M LEOPOLD	
		DATE: 28 SEP 03	
REVISION	APPR. BY:	1279-E10A-197586	
01	SCALE: 1=12		

01	03 MAY 05	ADDED BREAKOUT BOARD AND GREEN DIGIT ASSEMBLY NUMBERS.	MGL	
REV.	DATE	DESCRIPTION	BY	APPR.

TI-215-11/-21

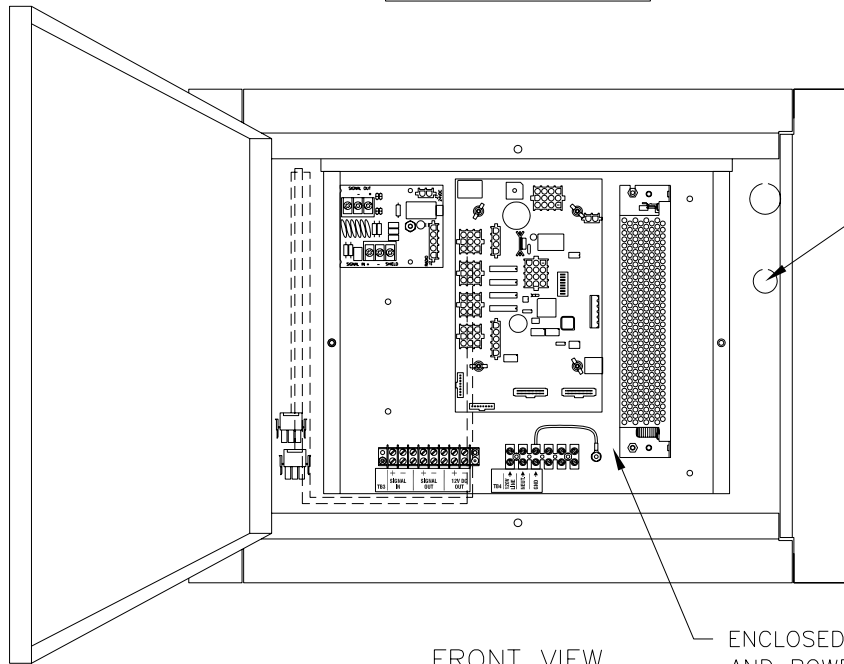

KNOCKOUTS FOR CONDUIT
(KNOCKOUTS CAN ALSO
BE FOUND ON BOTH SIDES
OF THIS DISPLAY)

FRONT VIEW
DOOR SHOWN OPEN

ENCLOSED 4 COLUMN LED DRIVER
AND POWER/SIGNAL ENCLOSURE.
(THE COVER HAS BEEN REMOVED
TO SHOW THE COMPONENT DETAIL).

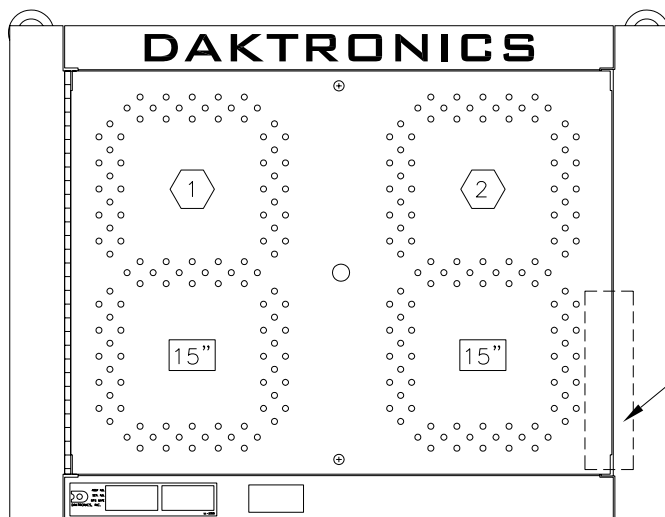

RADIO LOCATION
ANTENNA PROTRUDES
OUT END OF CABINET
(NOT FACE OF DISPLAY)

FRONT VIEW
DOOR SHOWN CLOSED

1 = DRIVER CONNECTOR
WIRED TO DIGIT

18" = DIGIT SIZE

THE CONCEPTS EXPRESSED AND DETAILS SHOWN ON THIS DRAWING ARE CONFIDENTIAL AND PROPRIETARY. DO NOT REPRODUCE BY ANY MEANS, INCLUDING ELECTRONICALLY WITHOUT THE EXPRESSED WRITTEN CONSENT OF DAKTRONICS, INC. COPYRIGHT 2003 DAKTRONICS, INC.			
DAKTRONICS, INC. BROOKINGS, SD 57006			
PROJ: OUTDOOR LED SCOREBOARDS			
TITLE: COMPONENT LOCATIONS; TI-215-11/-21, G3			
DES. BY: MCOPLAN		DRAWN BY: MCOPLAN	
		DATE: 22DEC03	
REVISION	APPR. BY:	1192-R08A-201607	
01	SCALE: 1=7		

01	21 SEPT 06	ADDED RADIO BRACKET	TAJ	
REV.	DATE	DESCRIPTION	BY	APPR.

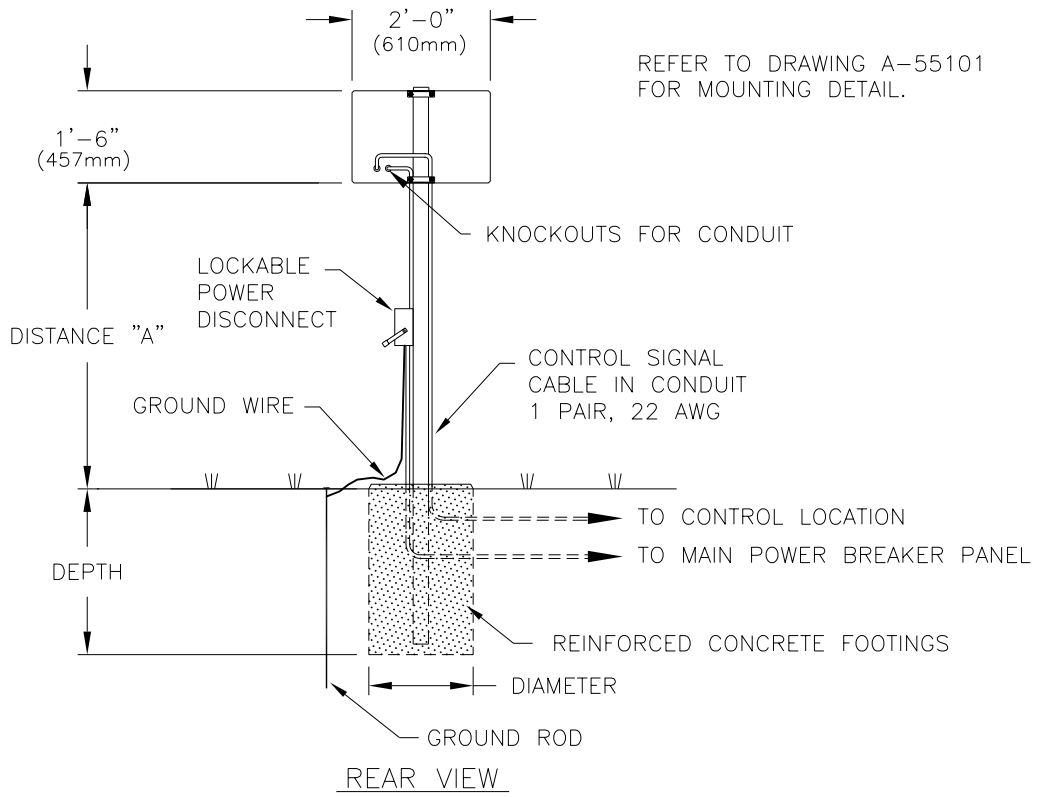

MODEL TI-215					
DISTANCE "A" (SEE FIGURE)	TOTAL DISPLAY SIZE		DESIGN WIND VELOCITY		
			70 MPH	80 MPH	100 MPH
10'-0"	2'-0" x 3'-0"	BEAM FOOTING	TS4x4x3/16 2.0' x 2.9'	TS4x4x3/16 2.0' x 3.2'	TS4x4x3/16 2.0' x 3.7'
12'-0"	2'-0" x 3'-0"	BEAM FOOTING	TS4x4x3/16 2.0' x 3.1'	TS6x4x3/16 2.0' x 3.4'	TS6x4x3/16 2.0' x 4.0'
14'-0"	2'-0" x 3'-0"	BEAM FOOTING	TS6x4x3/16 2.0' x 3.3'	TS6x4x3/16 2.0' x 3.7'	TS6x4x3/16 2.0' x 4.3'

FOOTING = DIAMETER X DEPTH

FOOTING DIMENSIONS ARE SUGGESTIONS ONLY, PROVIDED TO ASSIST WITH ESTIMATING INSTALLATION COSTS AND ARE NOT INTENDED FOR CONSTRUCTION PURPOSES.

FOOTING DIMENSIONS ARE BASED ON ASSUMED SOIL BEARING PRESSURE OF 2000 LB/FT²

ACTUAL FOOTING DEPTH AND DIAMETER FOR A PARTICULAR INSTALLATION MUST BE DETERMINED BY A QUALIFIED STRUCTURAL ENGINEER, USING DATA FROM A SOIL SAMPLE TEST AT THE SITE.

DAKTRONICS, INC. IS NOT RESPONSIBLE FOR STRUCTURES DESIGNED AND INSTALLED BY OTHERS.

THE CONCEPTS EXPRESSED AND DETAILS SHOWN ON THIS DRAWING ARE CONFIDENTIAL AND PROPRIETARY. DO NOT REPRODUCE BY ANY MEANS, INCLUDING ELECTRONICALLY WITHOUT THE EXPRESSED WRITTEN CONSENT OF DAKTRONICS, INC. COPYRIGHT 2003 DAKTRONICS, INC.

DAKTRONICS, INC. BROOKINGS, SD 57006

PROJ: OUTDOOR SCOREBOARDS

TITLE: INSTALLATION SPECIFICATIONS; TI-215

DES. BY: MCOPLAN

DRAWN BY: MCOPLAN

DATE: 23DEC03

REV.	DATE	DESCRIPTION	BY	APPR.
01	25 OCT 07	ADDED MILLIMETERS DIMENSIONS	KDD	

REVISION
01

APPR. BY:

SCALE: 1=50

1192-E10A-201655

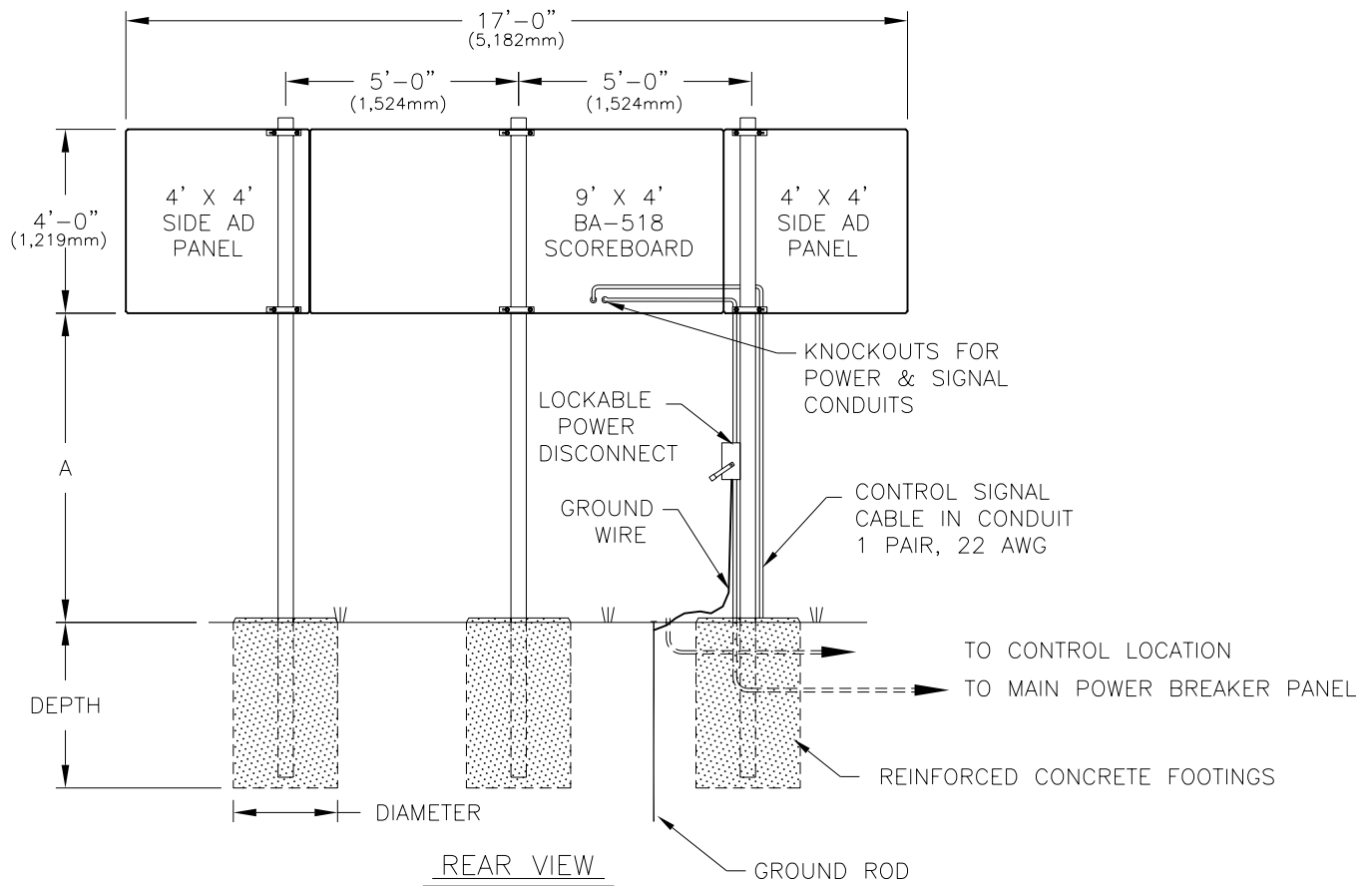

MODEL BA-518 WITH SIDE AD PANELS @2					
DISTANCE "A" (SEE FIGURE)	TOTAL DISPLAY SIZE		DESIGN WIND VELOCITY		
			70 MPH	80 MPH	100 MPH
10'-0"	17'-0" x 4'-0"	BEAM FOOTING	W10X15 3.0' x 4.7'	W10X15 3.0' x 5.2'	W8X18 3.0' x 6.1'
12'-0"	17'-0" x 4'-0"	BEAM FOOTING	W8X18 3.0' x 5.0'	W8X18 3.0' x 5.5'	W8X24 3.0' x 6.5'
14'-0"	17'-0" x 4'-0"	BEAM FOOTING	W6X20 3.0' x 5.3'	W8X24 3.0' x 5.8'	W12X26 3.0' x 6.8'

FOOTING = DIAMETER X DEPTH

FOOTING DIMENSIONS ARE SUGGESTIONS ONLY, PROVIDED TO ASSIST WITH ESTIMATING INSTALLATION COSTS AND ARE NOT INTENDED FOR CONSTRUCTION PURPOSES.

FOOTING DIMENSIONS ARE BASED ON ASSUMED SOIL BEARING PRESSURE OF 2000 LB/FT²

ACTUAL FOOTING DEPTH AND DIAMETER FOR A PARTICULAR INSTALLATION MUST BE DETERMINED BY A QUALIFIED STRUCTURAL ENGINEER, USING DATA FROM A SOIL SAMPLE TEST AT THE SITE.

DAKTRONICS, INC. IS NOT RESPONSIBLE FOR STRUCTURES DESIGNED AND INSTALLED BY OTHERS.

THE CONCEPTS EXPRESSED AND DETAILS SHOWN ON THIS DRAWING ARE CONFIDENTIAL AND PROPRIETARY. DO NOT REPRODUCE BY ANY MEANS, INCLUDING ELECTRONICALLY WITHOUT THE EXPRESSED WRITTEN CONSENT OF DAKTRONICS, INC. COPYRIGHT 2004 DAKTRONICS, INC.			
DAKTRONICS, INC. BROOKINGS, SD 57006			
PROJ: OUTDOOR SCOREBOARDS			
TITLE: INSTALLATION SPECIFICATIONS, BA-518 W/ 2 ADS			
DES. BY: JBRIGGS		DRAWN BY: MCOPLAN	
		DATE: 11MAY04	
REVISION	APPR. BY:	1091-R08A-211376	
01	SCALE: 1=50		

01	25 OCT 07	ADDED MILLIMETERS DIMENSIONS	KDD	
REV.	DATE	DESCRIPTION	BY	APPR.

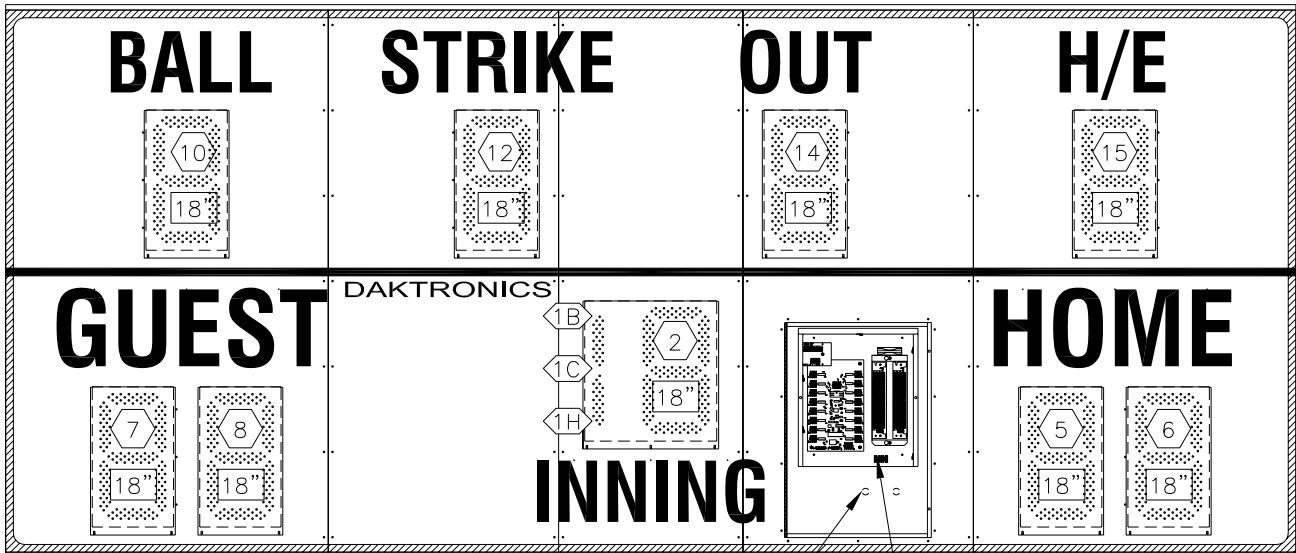

BA-1018-11/-21



KNOCKOUTS FOR
1/2" CONDUIT

FRONT VIEW

ENCLOSED 16 COLUMN LED DRIVER
AND POWER/SIGNAL ENCLOSURE.
(THE COVER HAS BEEN REMOVED
TO SHOW THE COMPONENT DETAIL).

-  = LED DRIVER CONNECTOR
WIRED TO THAT DIGIT.
-  = LED DRIVER CONNECTOR
AND SEGMENT (PIN) NO.
WIRED TO THAT INDICATOR
-  = DIGIT SIZE

HINGED ACCESS DOORS REMOVED
TO SHOW THE LED DRIVER AND
POWER/SIGNAL ENCLOSURE.

THE CONCEPTS EXPRESSED AND DETAILS SHOWN ON THIS DRAWING ARE CONFIDENTIAL AND PROPRIETARY. DO NOT REPRODUCE BY ANY MEANS, INCLUDING ELECTRONICALLY WITHOUT THE EXPRESSED WRITTEN CONSENT OF DAKTRONICS, INC. COPYRIGHT 2004 DAKTRONICS, INC.

DAKTRONICS, INC. BROOKINGS, SD 57006

PROJ: OUTDOOR LED SCOREBOARDS

TITLE: COMPONENT LOCATIONS; BA-1018-11/-21, FD, G3

DES. BY: MCOPLAN

DRAWN BY: MCOPLAN

DATE: 09NOV04

REVISION

APPR. BY:

SCALE: 1=25

1192-R08A-227184

REV.	DATE	DESCRIPTION	BY	APPR.
00				

BA-624-11/-21

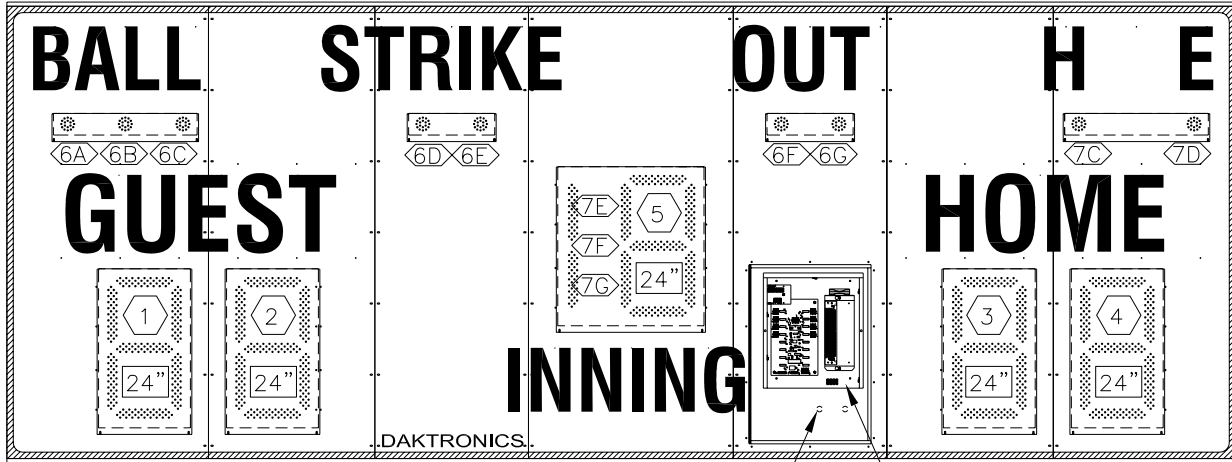

KNOCKOUTS FOR
1/2" CONDUIT.

ENCLOSED 8 COLUMN LED DRIVER
AND POWER/SIGNAL ENCLOSURE.
(THE COVER HAS BEEN REMOVED
TO SHOW THE COMPONENT DETAIL).

FRONT VIEW

① = LED DRIVER CONNECTOR
WIRED TO THAT DIGIT.

⑥A = LED DRIVER CONNECTOR
AND SEGMENT (PIN) NO.
WIRED TO THAT INDICATOR

24" = DIGIT SIZE

HINGED ACCESS DOORS REMOVED
TO SHOW THE LED DRIVER AND
POWER/SIGNAL ENCLOSURE.

THE CONCEPTS EXPRESSED AND DETAILS SHOWN ON THIS DRAWING ARE CONFIDENTIAL AND PROPRIETARY. DO NOT REPRODUCE BY ANY MEANS, INCLUDING ELECTRONICALLY WITHOUT THE EXPRESSED WRITTEN CONSENT OF DAKTRONICS, INC. COPYRIGHT 2004 DAKTRONICS, INC.

DAKTRONICS, INC. BROOKINGS, SD 57006

PROJ: OUTDOOR LED SCOREBOARDS

TITLE: COMPONENT LOCATIONS; BA-624-11/-21, FD, G3

DES. BY: MCOPLAN

DRAWN BY: MCOPLAN

DATE: 15NOV04

REVISION

APPR. BY:

00

SCALE: 1=30

1192-R08A-227767

REV.	DATE	DESCRIPTION	BY	APPR.
00				

MS-918-11/-21

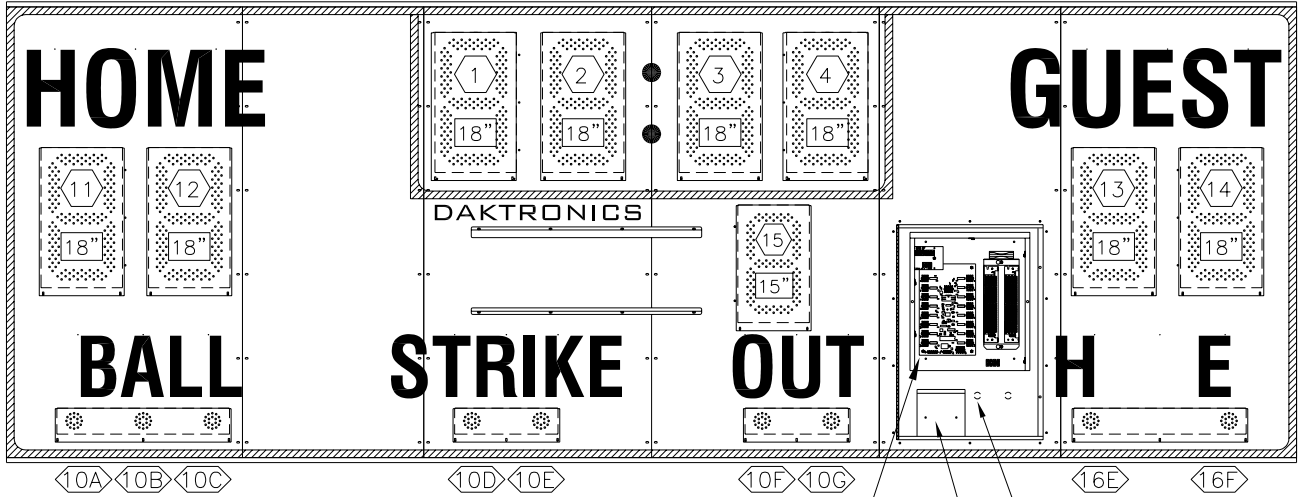

ENCLOSED 16 COLUMN LED DRIVER AND POWER/SIGNAL ENCLOSURE. (THE COVER HAS BEEN REMOVED TO SHOW COMPONENT DETAIL).

KNOCKOUTS FOR 1/2" CONDUIT

HORN (OPTIONAL)

FRONT VIEW

- ⬡12⬡ = LED DRIVER CONNECTOR WIRED TO THAT DIGIT.
- ⬡10H⬡ = LED DRIVER CONNECTOR AND SEGMENT (PIN) NO. WIRED TO THAT INDICATOR
- 18" = DIGIT SIZE

HINGED ACCESS DOORS REMOVED TO SHOW THE LED DRIVER AND POWER/SIGNAL ENCLOSURE.

THE CONCEPTS EXPRESSED AND DETAILS SHOWN ON THIS DRAWING ARE CONFIDENTIAL AND PROPRIETARY. DO NOT REPRODUCE BY ANY MEANS, INCLUDING ELECTRONICALLY WITHOUT THE EXPRESSED WRITTEN CONSENT OF DAKTRONICS, INC. COPYRIGHT 2004 DAKTRONICS, INC.			
DAKTRONICS, INC. BROOKINGS, SD 57006			
PROJ: OUTDOOR LED SCOREBOARDS			
TITLE: COMPONENT LOCATIONS; MS-918-11/-21, FD, G3			
DES. BY: MCOPLAN		DRAWN BY: MCOPLAN	
		DATE: 16NOV03	
REVISION	APPR. BY:	1192-R08A-227840	
00	SCALE: 1=25		

REV.	DATE	DESCRIPTION	BY	APPR.

BA-618-11/-21

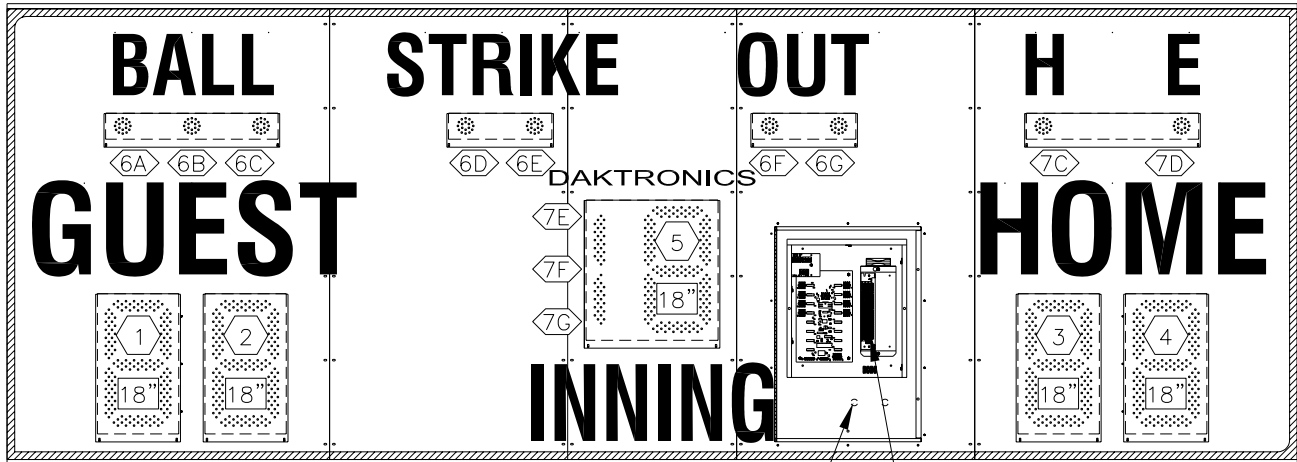

ENCLOSED 8 COLUMN LED DRIVER AND POWER/SIGNAL ENCLOSURE. (THE COVER HAS BEEN REMOVED TO SHOW COMPONENT DETAIL).

KNOCKOUTS FOR 1/2" CONDUIT

FRONT VIEW

- ⬡12 = DRIVER CONNECTOR WIRED TO THAT DIGIT.
- ⬡6A = DRIVER CONNECTOR AND SEGMENT (PIN) NO. WIRED TO THAT INDICATOR
- 18" = DIGIT SIZE

HINGED ACCESS DOORS REMOVED TO SHOW THE LED DRIVER AND POWER/SIGNAL ENCLOSURE.

THE CONCEPTS EXPRESSED AND DETAILS SHOWN ON THIS DRAWING ARE CONFIDENTIAL AND PROPRIETARY. DO NOT REPRODUCE BY ANY MEANS, INCLUDING ELECTRONICALLY WITHOUT THE EXPRESSED WRITTEN CONSENT OF DAKTRONICS, INC. COPYRIGHT 2004 DAKTRONICS, INC.			
DAKTRONICS, INC. BROOKINGS, SD 57006			
PROJ: OUTDOOR LED SCOREBOARDS			
TITLE: COMPONENT LOCATIONS; BA-618-11/-21, FD, G3			
DES. BY: MCOPLAN		DRAWN BY: MCOPLAN	
		DATE: 17NOV04	
REVISION	APPR. BY:	1192-R08A-227949	
00	SCALE: 1=25		

REV.	DATE	DESCRIPTION	BY	APPR.

FB-2005-11/-21

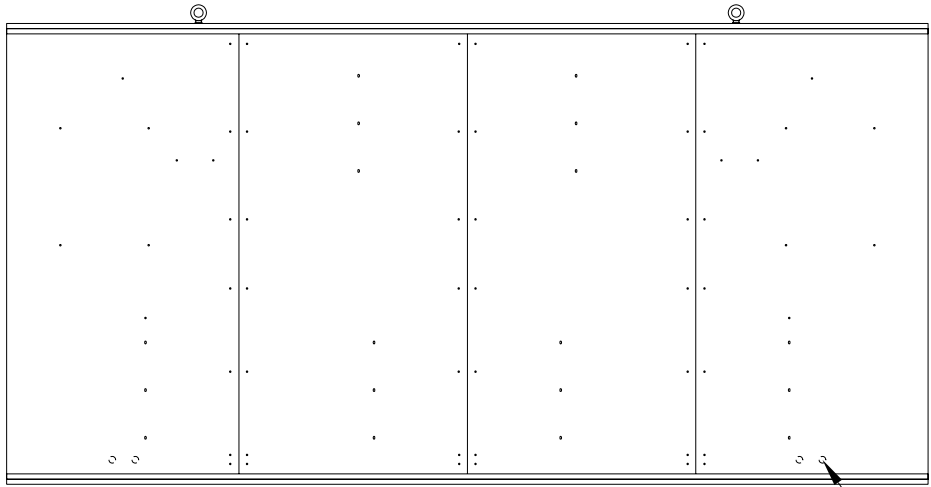

REAR VIEW

KNOCKOUT FOR
1/2" CONDUIT

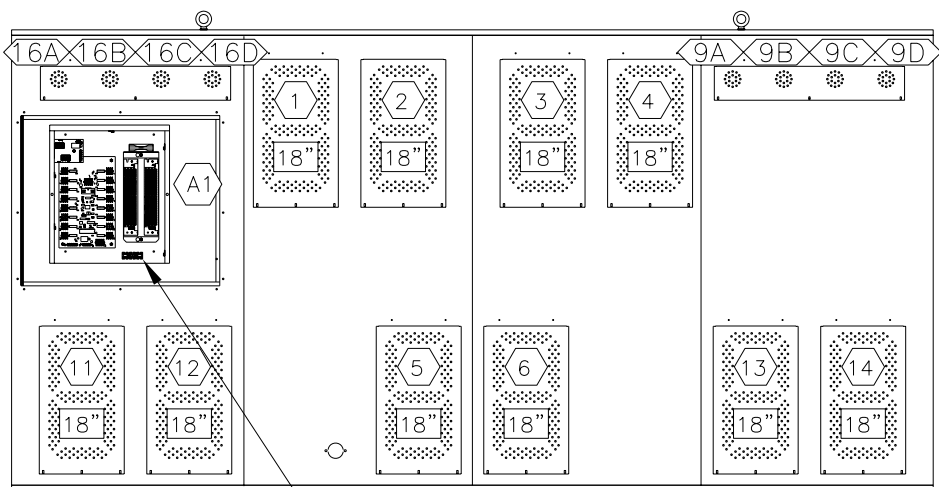

ENCLOSED 16 COLUMN DRIVER
AND POWER/SIGNAL ENCLOSURE.
(THE COVER HAS BEEN REMOVED
TO SHOW COMPONENT DETAIL).

FRONT VIEW
(DOORS SHOWN OPEN)

- ① = LED DRIVER CONNECTOR
WIRED TO THAT DIGIT.
- ⑥A = LED DRIVER CONNECTOR
AND SEGMENT (PIN) NO.
WIRED TO THAT INDICATOR
- 24" = DIGIT SIZE

HINGED ACCESS DOORS REMOVED
TO SHOW THE LED DRIVER AND
THE POWER/SIGNAL ENCLOSURE.

THE CONCEPTS EXPRESSED AND DETAILS SHOWN ON THIS DRAWING ARE CONFIDENTIAL AND PROPRIETARY. DO NOT REPRODUCE BY ANY MEANS, INCLUDING ELECTRONICALLY WITHOUT THE EXPRESSED WRITTEN CONSENT OF DAKTRONICS, INC. COPYRIGHT 2003 DAKTRONICS, INC.

DAKTRONICS, INC. BROOKINGS, SD 57006

PROJ: OUTDOOR LED SCOREBOARDS

TITLE: COMPONENT LOCATION DWG; FB-2005-11/21, FD, G3

DES. BY: KBRICKER DRAWN BY: KBRICKER DATE: 18NOV04

REVISION	APPR. BY:	1192-R08A-228192
01	SCALE: 1=25	

01	15NOV05	ADDED HORN MTG HOLES	TAJ	
REV.	DATE	DESCRIPTION	BY	APPR.

SO-2013-11/-21

DRIVER A1:
ENCLOSED 16 COLUMN MASTER LED DRIVER AND POWER/SIGNAL ENCLOSURE. (THE COVER HAS BEEN REMOVED TO SHOW THE COMPONENT DETAIL).

DRIVER A2:
ENCLOSED 16 COLUMN SLAVE LED DRIVER AND POWER/SIGNAL ENCLOSURE. (THE COVER HAS BEEN REMOVED TO SHOW THE COMPONENT DETAIL).

NOTE: ALL COMPONENTS ARE LOCATED BEHIND DIGIT PANELS.

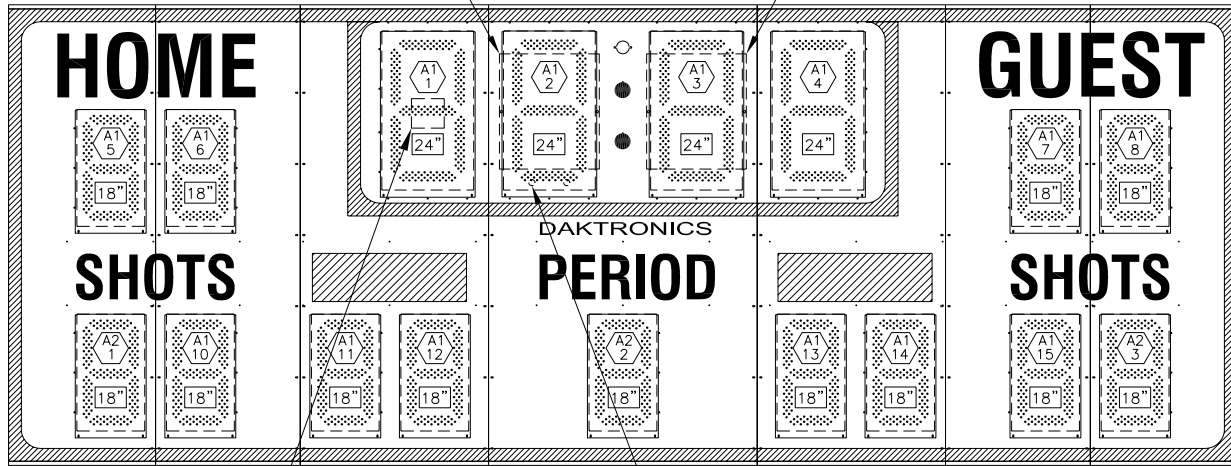

12V HORN ENCLOSURE (OPTIONAL)

KNOCKOUTS FOR 1/2" CONDUIT

FRONT VIEW

 = LED DRIVER AND CONNECTOR WIRED TO THAT DIGIT.

 = DIGIT SIZE

THE CONCEPTS EXPRESSED AND DETAILS SHOWN ON THIS DRAWING ARE CONFIDENTIAL AND PROPRIETARY. DO NOT REPRODUCE BY ANY MEANS, INCLUDING ELECTRONICALLY WITHOUT THE EXPRESSED WRITTEN CONSENT OF DAKTRONICS, INC. COPYRIGHT 2004 DAKTRONICS, INC.			
DAKTRONICS, INC. BROOKINGS, SD 57006			
PROJ: OUTDOOR LED SCOREBOARDS			
TITLE: COMPONENT LOCATIONS; SO-2013-11/-21, FD, G3			
DES. BY: MCOPLAN		DRAWN BY: MCOPLAN	
		DATE: 30NOV04	
REVISION	APPR. BY:	1192-R08A-228598	
00	SCALE: 1=30		

REV.	DATE	DESCRIPTION	BY	APPR.

BA-2004-11/-21

ENCLOSED 16 COLUMN SLAVE DRIVER AND POWER/SIGNAL ENCLOSURE @2.
(THE COVER HAS BEEN REMOVED TO SHOW THE COMPONENT DETAIL).

ENCLOSED 16 COLUMN MASTER DRIVER AND POWER/SIGNAL ENCLOSURE @1.
(THE COVER HAS BEEN REMOVED TO SHOW THE COMPONENT DETAIL).

KNOCKOUTS FOR CONDUIT PROVIDED IN REAR OF SCBD @2

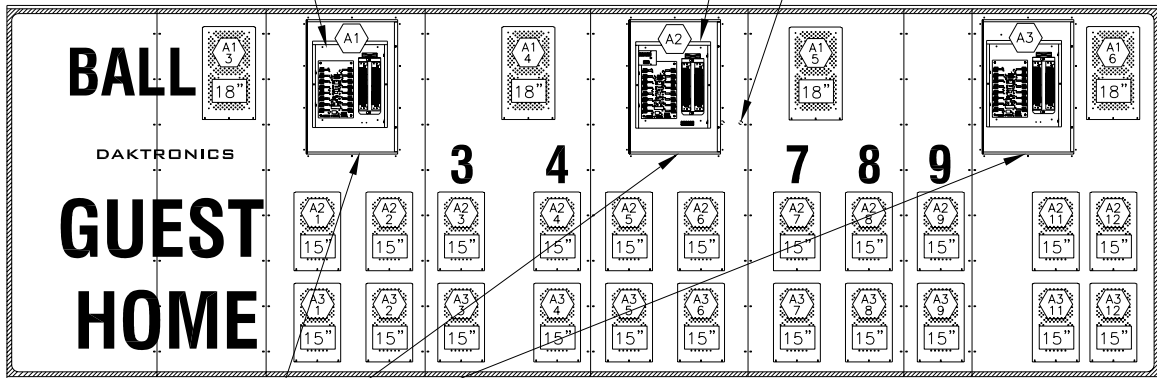

NOTE: SOME CAPTIONS HAVE BEEN REMOVED TO SHOW DETAIL

FRONT VIEW

BA-2004-11/-21 W/ TNMC

ENCLOSED 16 COLUMN SLAVE DRIVER AND POWER/SIGNAL ENCLOSURE @2.
(THE COVER HAS BEEN REMOVED TO SHOW THE COMPONENT DETAIL).

ENCLOSED 16 COLUMN MASTER DRIVER AND POWER/SIGNAL ENCLOSURE @1.
(THE COVER HAS BEEN REMOVED TO SHOW THE COMPONENT DETAIL).

KNOCKOUTS FOR CONDUIT PROVIDED IN REAR OF SCBD @2

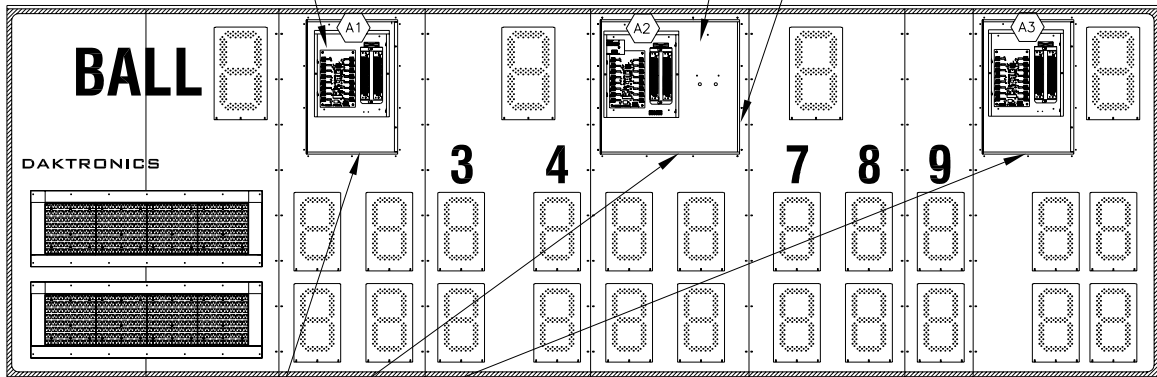

NOTE: SOME CAPTIONS HAVE BEEN REMOVED TO SHOW DETAIL

HINGED ACCESS DOORS REMOVED TO SHOW THE LED DRIVER AND THE POWER/SIGNAL ENCLOSURE.

18" = DIGIT SIZE

5 = LED DRIVER CONNECTOR

THE CONCEPTS EXPRESSED AND DETAILS SHOWN ON THIS DRAWING ARE CONFIDENTIAL AND PROPRIETARY. DO NOT REPRODUCE BY ANY MEANS, INCLUDING ELECTRONICALLY WITHOUT THE EXPRESSED WRITTEN CONSENT OF DAKTRONICS, INC. COPYRIGHT 2004 DAKTRONICS, INC.

DAKTRONICS, INC. BROOKINGS, SD 57006

PROJ: OUTDOOR LED SCOREBOARDS

TITLE: COMPONENT LOCATIONS; BA-2004-11/-21, FD, G3

DES. BY: KBRICKER

DRAWN BY: KBRICKER

DATE: 30 NOV 04

REVISION

APPR. BY:

00

SCALE: 1=40

1192-R08A-228668

REV.	DATE	DESCRIPTION	BY	APPR.

MS-2011-11/-21

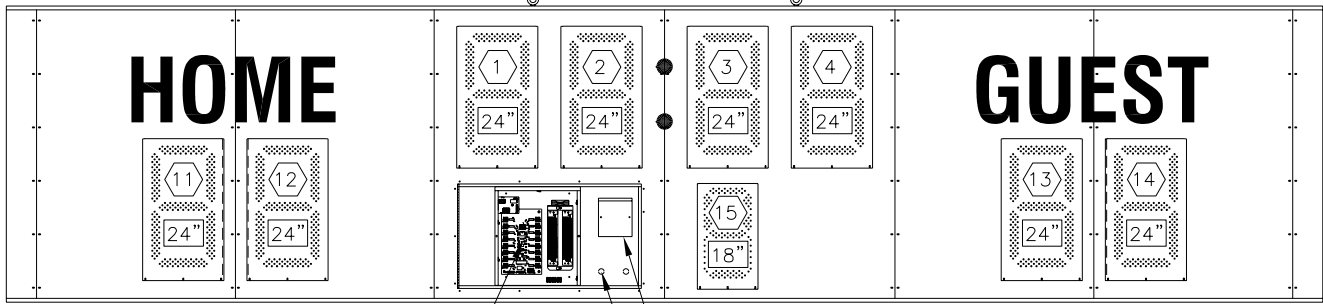

ENCLOSED 16 COLUMN LED DRIVER. (THE COVER IS REMOVED TO SHOW THE LED DRIVER.)

HORN (OPTIONAL)

KNOCKOUT FOR 1/2" CONDUIT

FRONT VIEW

(SHOWN WITH DOORS OPEN)

MS-2011-11/-21 W/ TNMC

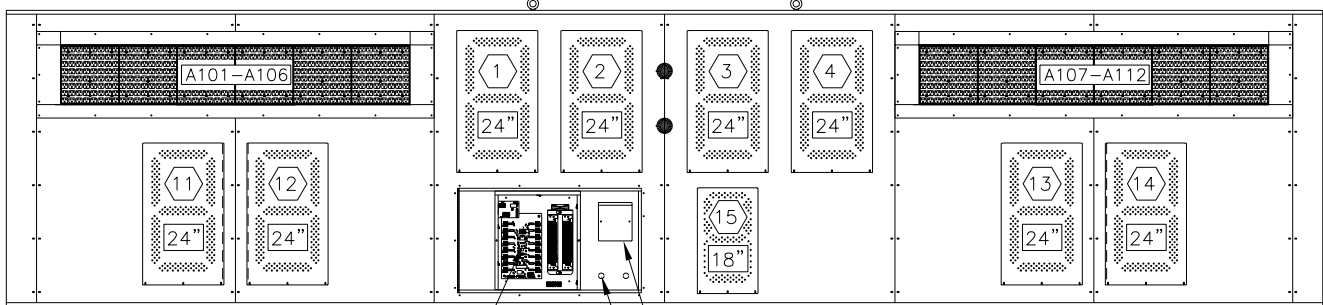

ENCLOSED 16 COLUMN LED DRIVER. (THE COVER IS REMOVED TO SHOW THE LED DRIVER.)

HORN (OPTIONAL)

KNOCKOUT FOR 1/2" CONDUIT

FRONT VIEW

(SHOWN WITH DOORS OPEN)

1 = LED DRIVER CONNECTOR WIRED TO THAT DIGIT.

24" = DIGIT SIZE

HINGED ACCESS DOORS REMOVED TO SHOW THE LED DRIVER AND POWER AND SIGNAL ENCLOSURE.

THE CONCEPTS EXPRESSED AND DETAILS SHOWN ON THIS DRAWING ARE CONFIDENTIAL AND PROPRIETARY. DO NOT REPRODUCE BY ANY MEANS, INCLUDING ELECTRONICALLY WITHOUT THE EXPRESSED WRITTEN CONSENT OF DAKTRONICS, INC. COPYRIGHT 2004 DAKTRONICS, INC.

DAKTRONICS, INC. BROOKINGS, SD 57006

PROJ: OUTDOOR LED SCOREBOARDS

TITLE: COMPONENT LOCATIONS; MS-2011-11/-21, FD, G3

DES. BY: MCOPLAN

DRAWN BY: MCOPLAN

DATE: 14DEC04

REVISION

APPR. BY:

00

SCALE: 1=35

1192-R08A-229459

REV.	DATE	DESCRIPTION	BY	APPR.

MS-2004-11/-21

ENCLOSED 16 COLUMN MASTER LED DRIVER AND POWER/SIGNAL ENCLOSURE ©1. (THE COVER HAS BEEN REMOVED TO SHOW THE ENCLOSURE COMPONENT DETAIL.)

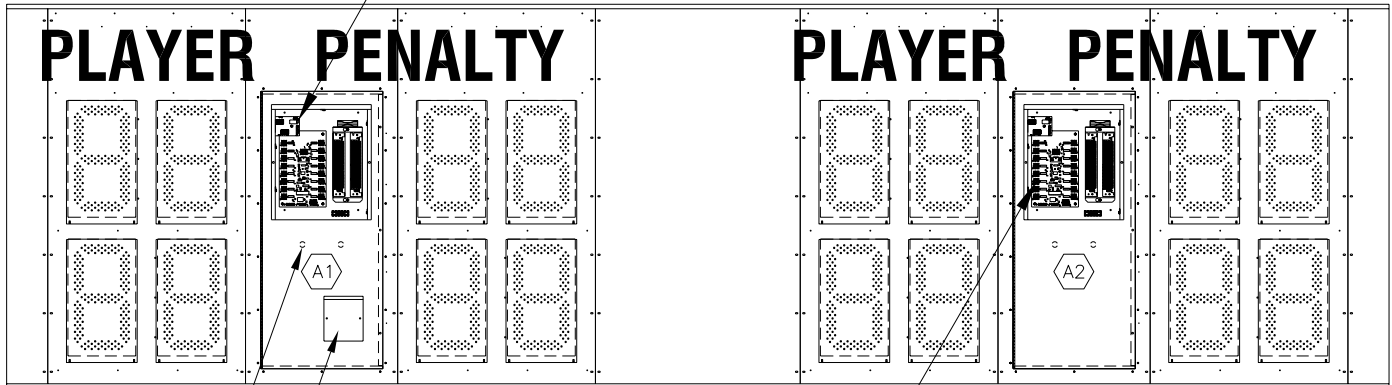

KNOCKOUTS FOR 1/2" CONDUIT

OPTIONAL 12V HORN

ENCLOSED 16 COLUMN SLAVE LED DRIVER AND POWER/SIGNAL ENCLOSURE ©1. (THE COVER HAS BEEN REMOVED TO SHOW THE ENCLOSURE COMPONENT DETAIL.)

FRONT VIEW
(DOORS SHOWN OPEN)

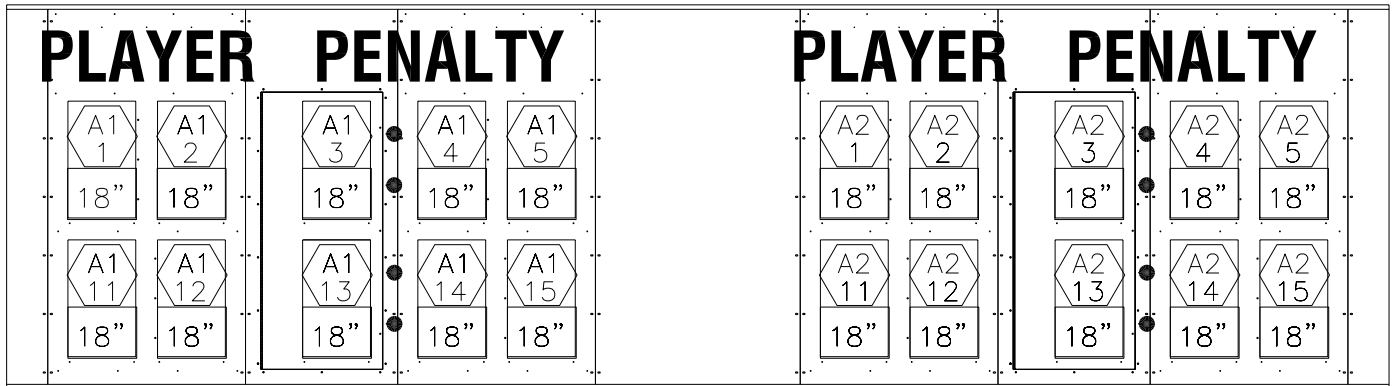

FRONT VIEW
(DOORS SHOWN CLOSED)



= LED DRIVER NUMBER & LED DRIVER CONNECTOR WIRED TO THAT DIGIT.



= DIGIT SIZE

THE CONCEPTS EXPRESSED AND DETAILS SHOWN ON THIS DRAWING ARE CONFIDENTIAL AND PROPRIETARY. DO NOT REPRODUCE BY ANY MEANS, INCLUDING ELECTRONICALLY WITHOUT THE EXPRESSED WRITTEN CONSENT OF DAKTRONICS, INC. COPYRIGHT 2004 DAKTRONICS, INC.

DAKTRONICS, INC. BROOKINGS, SD 57006

PROJ: OUTDOOR LED SCOREBOARDS

TITLE: COMPONENT LOCATIONS; MS-2004-11/-21, FD, G3

DES. BY: MCOPLAN

DRAWN BY: MCOPLAN

DATE: 16DEC04

REVISION

APPR. BY:

SCALE: 1=30

00

1192-R08A-229758

REV.	DATE	DESCRIPTION	BY	APPR.

REAR VIEW

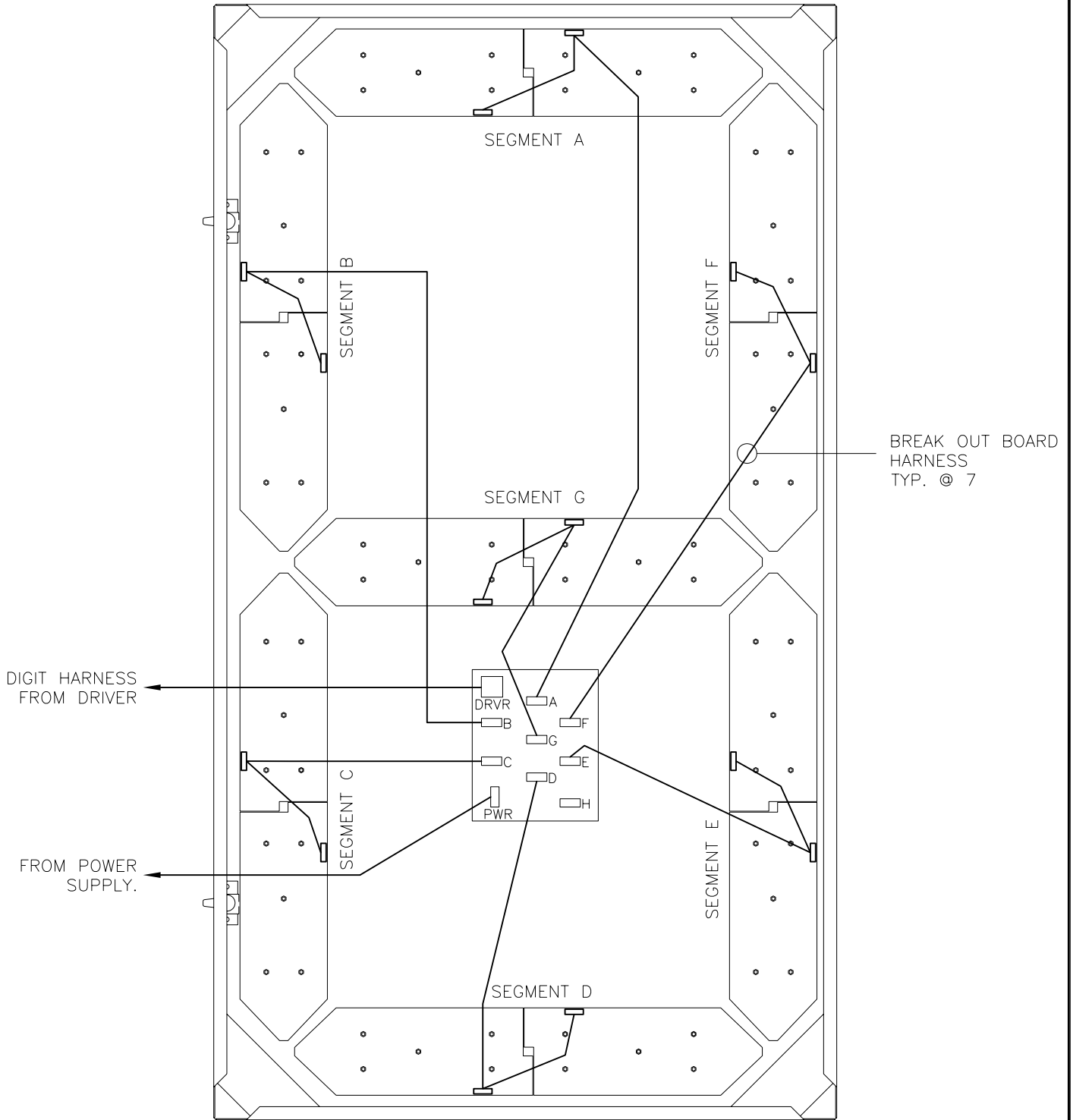

THE CONCEPTS EXPRESSED AND DETAILS SHOWN ON THIS DRAWING ARE CONFIDENTIAL AND PROPRIETARY. DO NOT REPRODUCE BY ANY MEANS, INCLUDING ELECTRONICALLY WITHOUT THE EXPRESSED WRITTEN CONSENT OF DAKTRONICS, INC. COPYRIGHT 2005 DAKTRONICS, INC.

DAKTRONICS, INC. BROOKINGS, SD 57006

PROJ: LED DATE TIME DISPLAYS

TITLE: HARNESS ASSEMBLY DIAGRAM; 60" DIGIT

DES. BY: MMILLER

DRAWN BY: MMILLER

DATE: 31 JAN 05

REVISION

APPR. BY:

SCALE: NONE

1279-R01A-232925

REV.	DATE	DESCRIPTION	BY	APPR.
00				

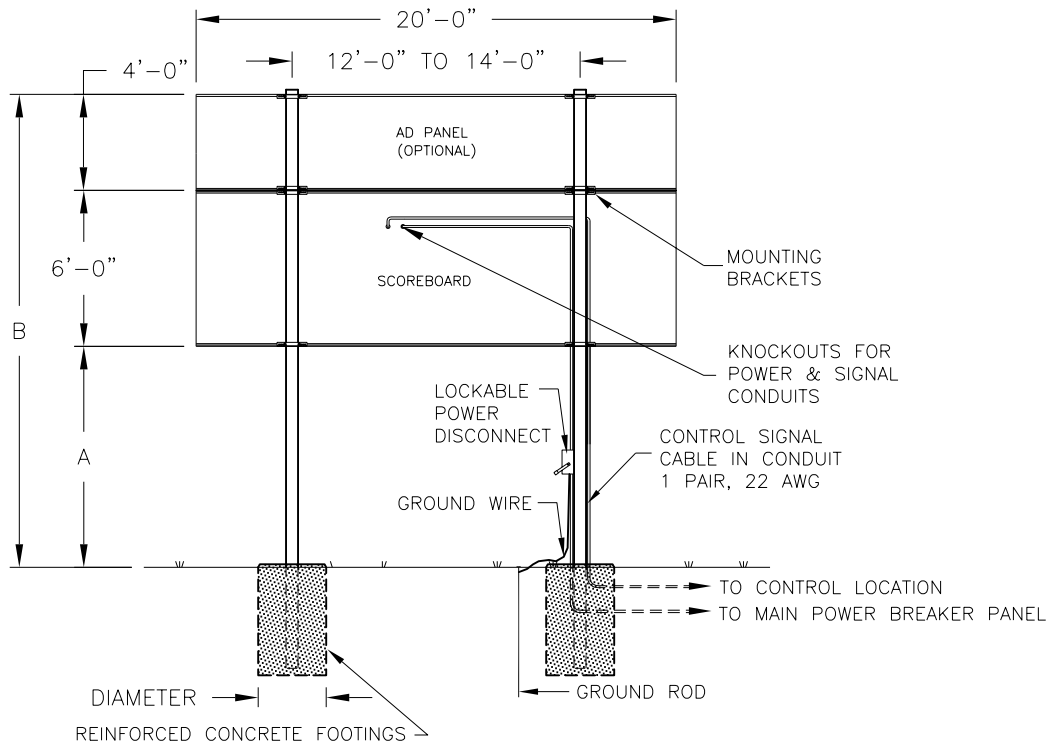

ELECTRICAL

REAR VIEW

POWER CABLE MUST HAVE A SEPERATE GROUND CONDUCTOR.
 SCOREBOARD MUST BE CONNECTED TO A GROUND ROD AT SCOREBOARD LOCATION.

BA-2019							
VERTICAL DISTANCE (A)	AD PANEL HEIGHT	COMBINED HEIGHT (B)		DESIGN WIND VELOCITY			
				70 MPH	80 MPH	90 MPH	100 MPH
10 FT	NONE	16'-0"	BEAM	W8x18	W6x20	W8x24	W8x24
			FOOTING	2.5'x5.8'	2.5'x6.2'	2.5'x6.7'	2.5'x7.3'
	4 FT	20'-0"	BEAM	W8x28	W8x31	W8x31	W10x33
			FOOTING	2.5'x6.9'	2.5'x7.7'	2.5'x8.4'	2.5'x9.0'
12 FT	NONE	18'-0"	BEAM	W6x20	W8x24	W8x28	W8x28
			FOOTING	2.5'x5.9'	2.5'x6.5'	2.5'x7.1'	2.5'x7.7'
	4 FT	22'-0"	BEAM	W8x31	W8x31	W10x33	W10x39
			FOOTING	2.5'x7.3'	2.5'x8.0'	2.5'x8.8'	2.5'x9.5'
14 FT	NONE	20'-0"	BEAM	W8x28	W8x28	W8x31	W8x31
			FOOTING	2.5'x6.1'	2.5'x6.8'	2.5'x7.4'	2.5'x8.0'
	4 FT	24'-0"	BEAM	W10x33	W10x39	W10x39	W10x45
			FOOTING	2.5'x7.6'	2.5'x8.3'	2.5'x9.1'	2.5'x9.8'
16 FT	NONE	22'-0"	BEAM	W8x31	W8x31	W8x31	W10x33
			FOOTING	2.5'x6.5'	2.5'x7.1'	2.5'x7.8'	2.5'x8.4'
	4 FT	26'-0"	BEAM	W10x39	W10x39	W10x45	W10x49
			FOOTING	2.5'x7.9'	2.5'x8.7'	2.5'x9.4'	2.5'x10.2'
18 FT	NONE	24'-0"	BEAM	W8x31	W8x31	W10x33	W10x39
			FOOTING	2.5'x6.7'	2.5'x7.3'	2.5'x8.0'	2.5'x8.6'
	4 FT	28'-0"	BEAM	W10x39	W10x45	W10x49	W10x60
			FOOTING	2.5'x8.1'	2.5'x8.9'	2.5'x9.7'	2.5'x10.5'
20 FT	NONE	26'-0"	BEAM	W10x33	W8x35	W10x39	W10x45
			FOOTING	2.5'x7.0'	2.5'x7.7'	2.5'x8.4'	2.5'x9.0'
	4 FT	30'-0"	BEAM	W10x45	W10x49	W10x60	W10x68
			FOOTING	2.5'x8.4'	2.5'x9.2'	2.5'x10.1'	2.5'x10.9'

FOOTING DIMENSIONS ARE SUGGESTIONS ONLY, PROVIDED TO ASSIST WITH ESTIMATING INSTALLATION COSTS, AND ARE NOT INTENDED FOR CONSTRUCTION PURPOSES.

COLUMNS AND FOOTINGS MUST BE DESIGNED BY A STATE LICENCED ENGINEER. DAKTRONICS DOES NOT ASSUME ANY LIABILITY FOR ANY INSTALLATIONS DERIVED FROM THIS INFORMATION OR DESIGNED AND INSTALLED BY OTHERS.

A NOTE ABOUT BEAM NOMENCLATURE:

For a typical beam, W12x30 for example, "W" stands for "Wide-Flange Beam". The first number (12) is the approximate front to rear dimension of the beam in inches. The second number (30) is the weight per foot in pounds. This numbering is standard in the steel industry. Widths vary from 8 to 14 inches in this chart.

FOOTING = DIAMETER X DEPTH

THE CONCEPTS EXPRESSED AND DETAILS SHOWN ON THIS DRAWING ARE CONFIDENTIAL AND PROPRIETARY. DO NOT REPRODUCE BY ANY MEANS, INCLUDING ELECTRONICALLY WITHOUT THE EXPRESSED WRITTEN CONSENT OF DAKTRONICS, INC. COPYRIGHT 2005 DAKTRONICS, INC.			
DAKTRONICS, INC. BROOKINGS, SD 57006			
PROJ: OUTDOOR INCANDESCENT SCORBOARDS			
TITLE: INSTALLATION SPECIFICATIONS; BA-2019-11/21			
DES. BY: MCOPLAN		DRAWN BY: TJOHNSON	
		DATE: 04 FEB 05	
REVISION	APPR. BY:	1192-R10A-233487	
01	SCALE: 1=96		

01	03FEB05	ADDED BEAMS AND FOOTINGS	JLB	
REV.	DATE	DESCRIPTION	BY	APPR.

ENCLOSED 16 COLUMN SLAVE DRIVER AND POWER/SIGNAL ENCLOSURE @2.
(THE COVER HAS BEEN REMOVED TO SHOW THE COMPONENT DETAIL).

BA-2005-11/-21 FD

ENCLOSED 16 COLUMN MASTER DRIVER AND POWER/SIGNAL ENCLOSURE @1.
(THE COVER HAS BEEN REMOVED TO SHOW THE COMPONENT DETAIL).

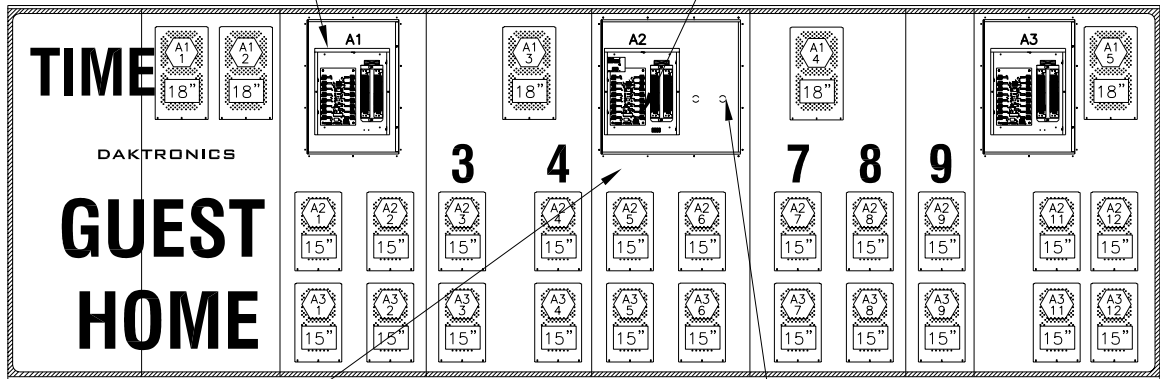

NOTE: SOME CAPTIONS HAVE BEEN REMOVED TO SHOW DETAIL

KNOCKOUTS FOR 1/2" CONDUIT

FRONT VIEW

BA-2005-11/-21 W/ TNMC, FD

ENCLOSED 16 COLUMN SLAVE DRIVER AND POWER/SIGNAL ENCLOSURE @2.
(THE COVER HAS BEEN REMOVED TO SHOW THE COMPONENT DETAIL).

ENCLOSED 16 COLUMN MASTER DRIVER AND POWER/SIGNAL ENCLOSURE @1.
(THE COVER HAS BEEN REMOVED TO SHOW THE COMPONENT DETAIL).

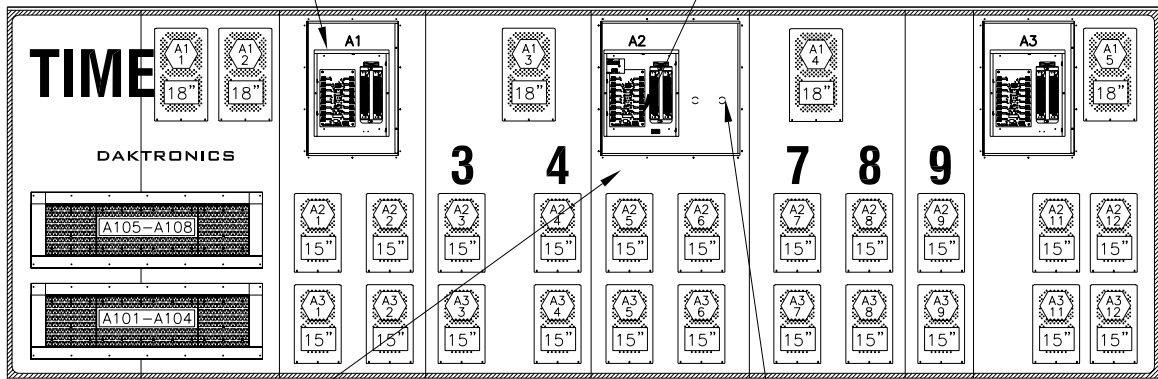

NOTE: SOME CAPTIONS HAVE BEEN REMOVED TO SHOW DETAIL

KNOCKOUTS FOR 1/2" CONDUIT

FRONT VIEW

5 = LED DRIVER CONNECTOR WIRED TO THAT DIGIT.

18" = DIGIT SIZE

HINGED ACCESS DOORS REMOVED TO SHOW THE LED DRIVER AND THE POWER/SIGNAL ENCLOSURE.

THE CONCEPTS EXPRESSED AND DETAILS SHOWN ON THIS DRAWING ARE CONFIDENTIAL AND PROPRIETARY. DO NOT REPRODUCE BY ANY MEANS, INCLUDING ELECTRONICALLY WITHOUT THE EXPRESSED WRITTEN CONSENT OF DAKTRONICS, INC. COPYRIGHT 2005 DAKTRONICS, INC.

DAKTRONICS, INC. BROOKINGS, SD 57006

PROJ: OUTDOOR LED SCOREBOARDS

TITLE: COMPONET LOCATIONS; BA-2005-11/-21 FD

DES. BY: CCAIN

DRAWN BY: CCAIN

DATE: 17 FEB 05

REVISION

APPR. BY:

SCALE: 1=40

1192-R08A-234592

REV.	DATE	DESCRIPTION	BY	APPR.
00				

CR-2002-11/-21

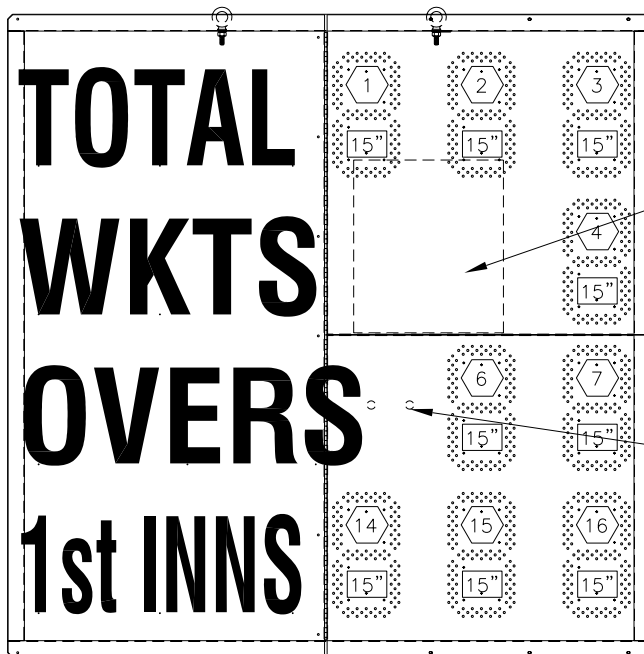

ENCLOSED 16 COLUMN LED DRIVER AND POWER/SIGNAL ENCLOSURE. (BEHIND DOOR).

KNOCKOUTS FOR 1/2" CONDUIT (BEHIND DOOR)

FRONT VIEW

 = LED DRIVER CONNECTOR WIRED TO THAT DIGIT.

THE CONCEPTS EXPRESSED AND DETAILS SHOWN ON THIS DRAWING ARE CONFIDENTIAL AND PROPRIETARY. DO NOT REPRODUCE BY ANY MEANS, INCLUDING ELECTRONICALLY WITHOUT THE EXPRESSED WRITTEN CONSENT OF DAKTRONICS, INC. COPYRIGHT 2005 DAKTRONICS, INC.

DAKTRONICS, INC. BROOKINGS, SD 57006

PROJ: CLUB INFORMATIVE CRICKET

TITLE: COMPONET LOCATION, CR-2002-11/21

DES. BY: CCAIN

DRAWN BY: CCAIN

DATE: 25 FEB 05

REVISION

APPR. BY:

SCALE: 1=20

1344-R08A-235279

REV.	DATE	DESCRIPTION	BY	APPR.
00				

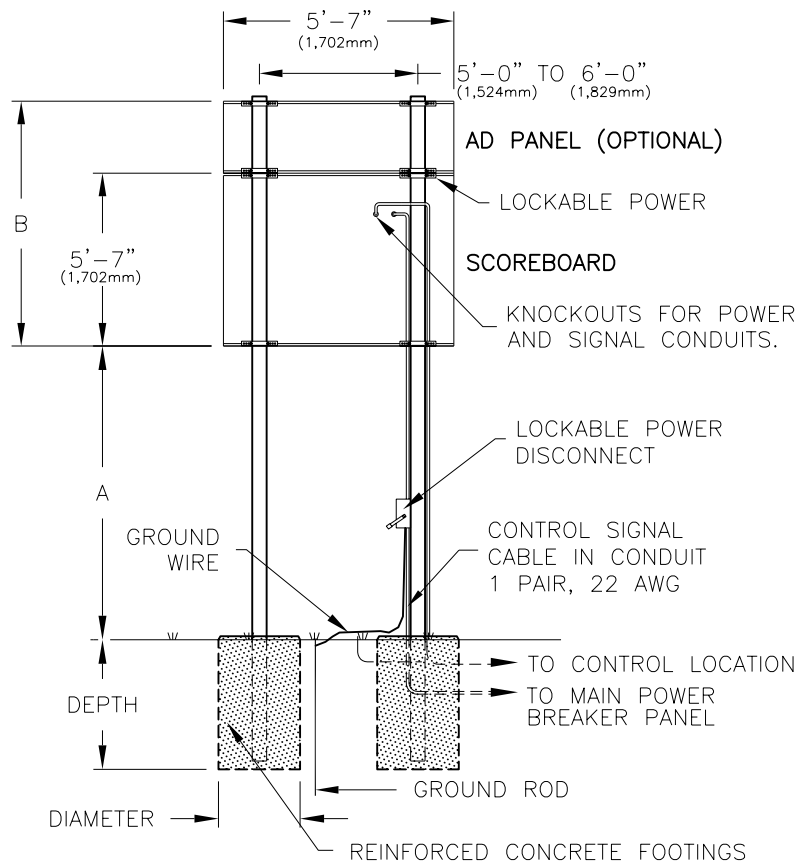

CR-2002
REAR VIEW

CR-2002						
VERTICAL DISTANCE (A)	AD PANEL HEIGHT	COMBINED HEIGHT (B)		DESIGN WIND VELOCITY		
				70 MPH	80 MPH	100 MPH
10 FT	NONE	6'-0"	BEAM	W6X15	W6X15	W6X20
			FOOTING	2.0X5.0	2.0X5.6	2.0X6.5
	2'-0"	8'-0"	BEAM	W8X18	W6X20	W8X24
			FOOTING	2.0X5.6	2.0X6.2	2.0X7.3
12 FT	NONE	6'-0"	BEAM	W8X18	W6X20	W8X24
			FOOTING	2.0X5.3	2.0X5.9	2.0X6.9
	2'-0"	8'-0"	BEAM	W6X20	W8X28	W8X31
			FOOTING	2.0X5.9	2.0X6.5	2.0X7.6
14 FT	NONE	6'-0"	BEAM	W6X20	W8X24	W8X28
			FOOTING	2.0X5.6	2.0X6.1	2.0X7.2
	2'-0"	8'-0"	BEAM	W8X28	W8X31	W8X31
			FOOTING	2.0X6.2	2.0X6.8	2.0X8.0

FOOTING DIMENSIONS ARE SUGGESTIONS ONLY, PROVIDED TO ASSIST WITH ESTIMATING INSTALLATION COSTS AND ARE NOT INTENDED FOR CONSTRUCTION PURPOSES.

FOOTING = DIAMETER X DEPTH

FOOTING DIMENSIONS ARE BASED ON ASSUMED SOIL BEARING PRESSURE OF 2000 LB/FT²

ACTUAL FOOTING DEPTH AND DIAMETER FOR A PARTICULAR INSTALLATION MUST BE DETERMINED BY A QUALIFIED STRUCTURAL ENGINEER, USING DATA FROM A SOIL SAMPLE TEST AT THE SITE.

DAKTRONICS, INC. IS NOT RESPONSIBLE FOR STRUCTURES DESIGNED AND INSTALLED BY OTHERS.

THE CONCEPTS EXPRESSED AND DETAILS SHOWN ON THIS DRAWING ARE CONFIDENTIAL AND PROPRIETARY. DO NOT REPRODUCE BY ANY MEANS, INCLUDING ELECTRONICALLY WITHOUT THE EXPRESSED WRITTEN CONSENT OF DAKTRONICS, INC. COPYRIGHT 2005 DAKTRONICS, INC.

DAKTRONICS, INC. BROOKINGS, SD 57006

PROJ: **CRICKET SCOREBOARDS**

TITLE: **INSTALLATION SPECIFICATIONS; CR-2002**

DES. BY: **RNEYEN**

DRAWN BY: **CCAIN**

DATE: **01 MAR 05**

01	25 OCT 07	ADDED MILLIMETERS DIMENSIONS	KDD	
REV.	DATE	DESCRIPTION	BY	APPR.

REVISION	APPR. BY:
01	SCALE: 1=80

1344-R10A-235517

MS-2002-11/-21

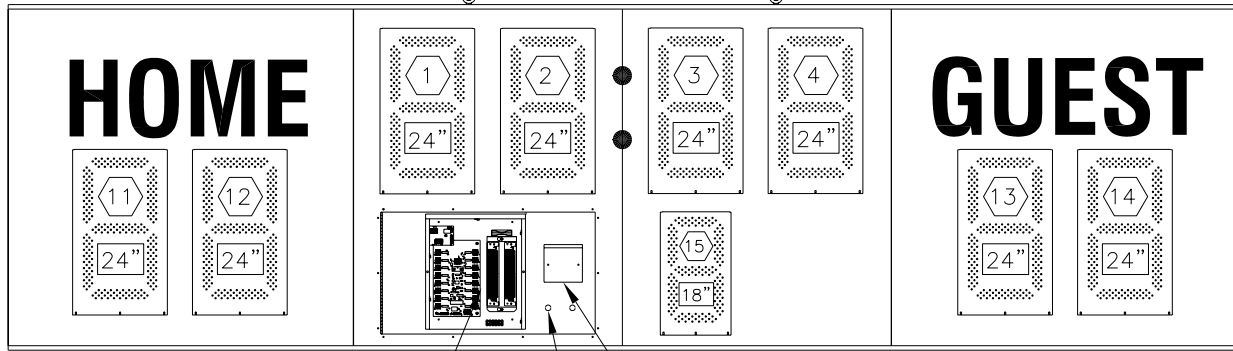

ENCLOSED 16 COLUMN LED DRIVER. (THE COVER IS REMOVED TO SHOW THE LED DRIVER.)

HORN (OPTIONAL)

KNOCKOUT FOR 1/2" CONDUIT

FRONT VIEW

MS-2002-11/-21 W/ TNMC

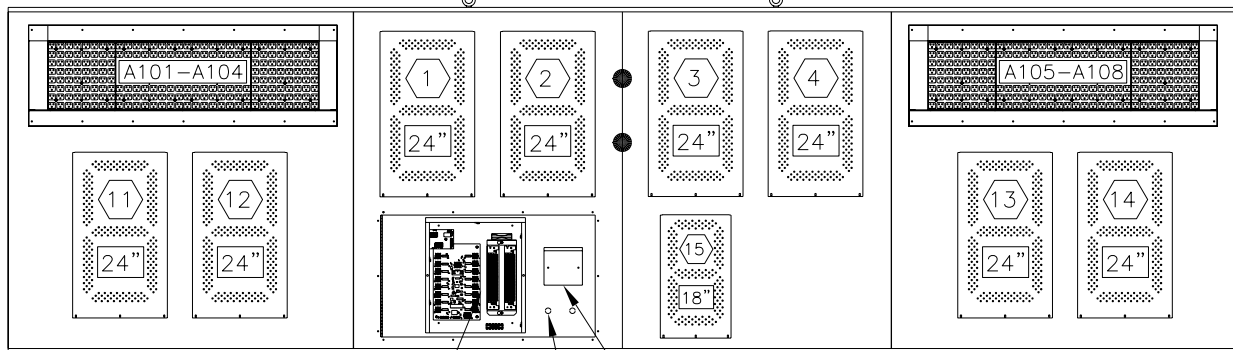

ENCLOSED 16 COLUMN LED DRIVER. (THE COVER IS REMOVED TO SHOW THE LED DRIVER.)

HORN (OPTIONAL)

KNOCKOUT FOR 1/2" CONDUIT

FRONT VIEW

① = LED DRIVER CONNECTOR WIRED TO THAT DIGIT.

24" = DIGIT SIZE

HINGED ACCESS DOORS REMOVED TO SHOW THE LED DRIVER AND POWER AND SIGNAL ENCLOSURE.

THE CONCEPTS EXPRESSED AND DETAILS SHOWN ON THIS DRAWING ARE CONFIDENTIAL AND PROPRIETARY. DO NOT REPRODUCE BY ANY MEANS, INCLUDING ELECTRONICALLY WITHOUT THE EXPRESSED WRITTEN CONSENT OF DAKTRONICS, INC. COPYRIGHT 2005 DAKTRONICS, INC.

DAKTRONICS, INC. BROOKINGS, SD 57006

PROJ: OUTDOOR LED SCOREBOARDS

TITLE: COMPONET LOCATIONS; MS-2002-11/21, G3, FD

DES. BY: CCAIN

DRAWN BY: CCAIN

DATE: 04 MAR 05

01	16 NOV 06	REMOVED ACCESS DOOR	AJS	
REV.	DATE	DESCRIPTION	BY	APPR.

REVISION	APPR. BY:
01	SCALE: 1=35

1192-R08A-235932

TI-2024-11/21

ENCLOSED 16 COLUMN LED DRIVER. (BEHIND DIGIT.)

6'-0"

4'-6"

RADIO BRACKET

ANTENNA HOLE

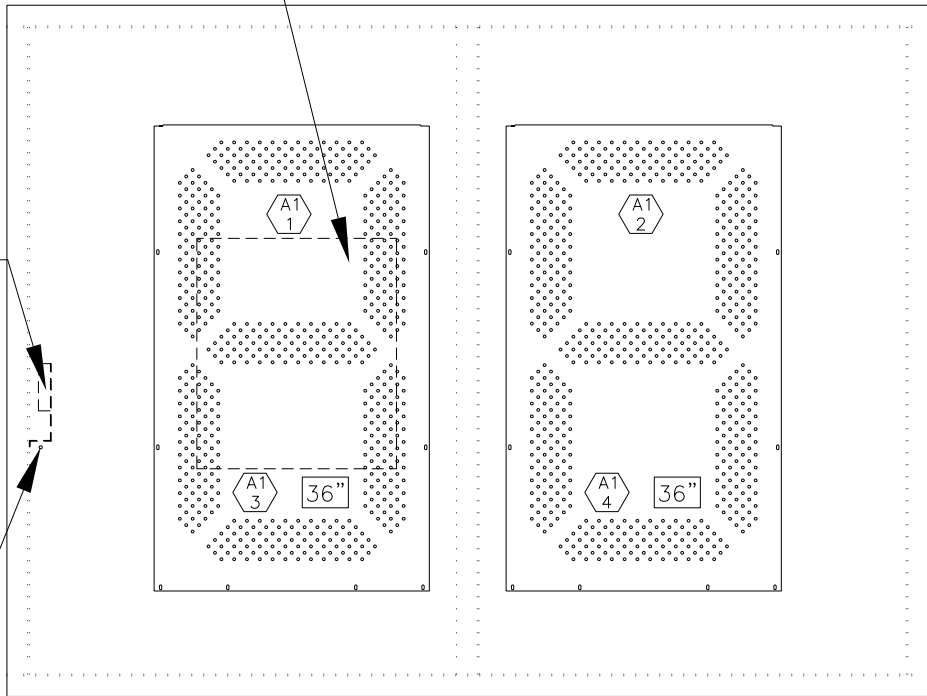

 = LED DRIVER NUMBER & LED DRIVER CONNECTOR WIRED TO THAT DIGIT.

 = DIGIT SIZE

THE CONCEPTS EXPRESSED AND DETAILS SHOWN ON THIS DRAWING ARE CONFIDENTIAL AND PROPRIETARY. DO NOT REPRODUCE BY ANY MEANS, INCLUDING ELECTRONICALLY WITHOUT THE EXPRESSED WRITTEN CONSENT OF DAKTRONICS, INC. COPYRIGHT 2005 DAKTRONICS, INC.			
DAKTRONICS, INC. BROOKINGS, SD 57006			
PROJ: OUTDOOR LED SCOREBOARDS			
TITLE: COMP. LOCATIONS, TI-2024-11/21, 36" DOG CLOCK			
DES. BY: CCAIN		DRAWN BY: CCAIN	
		DATE: 08 MAR 05	
REVISION	APPR. BY:	1192-R06A-236131	
01	SCALE: 1=15		

01	26SEPT06	ADDED RADIO BRACKET	TAJ	
REV.	DATE	DESCRIPTION	BY	APPR.

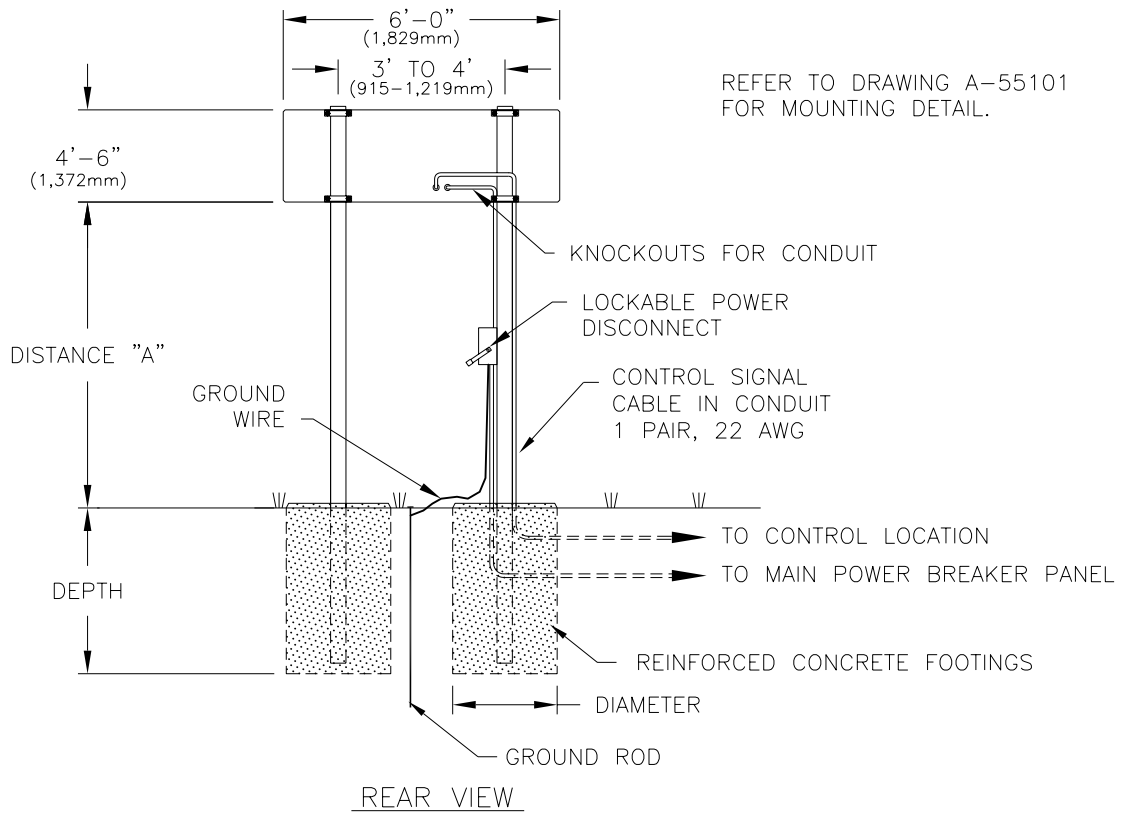

MODEL TI-2024					
DISTANCE "A" (SEE FIGURE)	TOTAL DISPLAY SIZE		DESIGN WIND VELOCITY		
			70 MPH	80 MPH	100 MPH
10'-0"	4'-6" x 6'-0"	BEAM FOOTING	W10x12 2.0 X 4.1	W10x12 2.0 X 4.5	W10x15 2.0 X 5.3
12'-0"	4'-6" x 6'-0"	BEAM FOOTING	W10x15 2.0 X 4.4	W10x15 2.0 X 4.8	W8x18 2.0 X 5.7
14'-0"	4'-6" x 6'-0"	BEAM FOOTING	W6x15 2.0 X 4.6	W8x18 2.0 X 5.1	W6x20 2.0 X 6.0

FOOTING = DIAMETER X DEPTH

FOOTING DIMENSIONS ARE SUGGESTIONS ONLY, PROVIDED TO ASSIST WITH ESTIMATING INSTALLATION COSTS AND ARE NOT INTENDED FOR CONSTRUCTION PURPOSES.

FOOTING DIMENSIONS ARE BASED ON ASSUMED SOIL BEARING PRESSURE OF 2000 LB/FT²

ACTUAL FOOTING DEPTH AND DIAMETER FOR A PARTICULAR INSTALLATION MUST BE DETERMINED BY A QUALIFIED STRUCTURAL ENGINEER, USING DATA FROM A SOIL SAMPLE TEST AT THE SITE.

DAKTRONICS, INC. IS NOT RESPONSIBLE FOR STRUCTURES DESIGNED AND INSTALLED BY OTHERS.

THE CONCEPTS EXPRESSED AND DETAILS SHOWN ON THIS DRAWING ARE CONFIDENTIAL AND PROPRIETARY. DO NOT REPRODUCE BY ANY MEANS, INCLUDING ELECTRONICALLY WITHOUT THE EXPRESSED WRITTEN CONSENT OF DAKTRONICS, INC. COPYRIGHT 2002 DAKTRONICS, INC.					
DAKTRONICS, INC. BROOKINGS, SD 57006					
PROJ: OUTDOOR SCOREBOARDS					
TITLE: INSTALLATION SPECS; TI-2024					
DES. BY: CCAIN		DRAWN BY: CCAIN		DATE: 08 MAR 05	
REVISION	APPR. BY:	1192-E10A-236147			
02	SCALE: 1=50				

REV.	DATE	DESCRIPTION	BY	APPR.
02	25 OCT 07	ADDED MILLIMETERS DIMENSIONS	KDD	
01	20APRIL05	CHANGED COLUMN AND FOOTING DIMENSIONS	JLB	

SO-2008-11/-21, FD

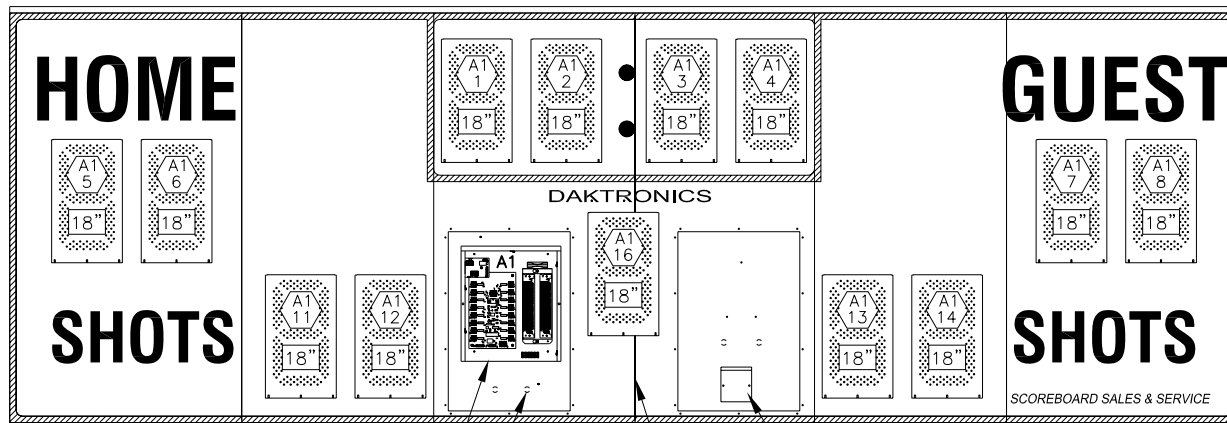

ENCLOSED 16 COLUMN LED DRIVER AND POWER AND SIGNAL ENCLOSURE. (THE COVER HAS BEEN REMOVED TO SHOW THE LED DRIVER).

HORN (OPTIONAL)

NOTE THAT THE PERIOD CAPTION AND ACCESS DOORS HAVE BEEN REMOVED TO SHOW DETAIL.

KNOCKOUT FOR 1/2" CONDUIT

SO-2008-11/-21 W/ TNMC, FD

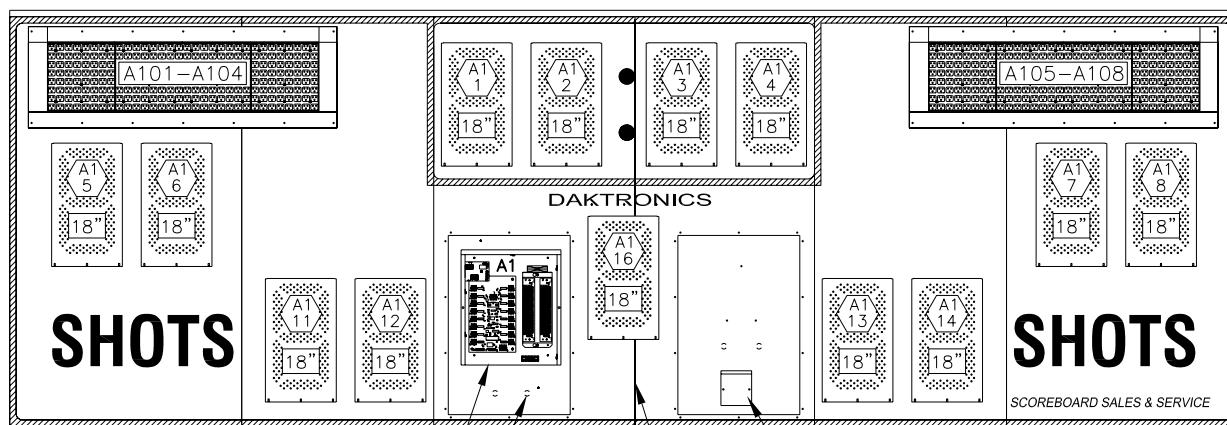

ENCLOSED 16 COLUMN LED DRIVER AND POWER AND SIGNAL ENCLOSURE. (THE COVER HAS BEEN REMOVED TO SHOW THE LED DRIVER).

HORN (OPTIONAL)

NOTE THAT THE PERIOD CAPTION AND ACCESS DOORS HAVE BEEN REMOVED TO SHOW DETAIL.

KNOCKOUT FOR 1/2" CONDUIT

24" = DIGIT SIZE

A1 1 = LED DRIVER NUMBER & LED DRIVER CONNECTOR WIRED TO THAT DIGIT.

HINGED ACCESS DOORS REMOVED TO SHOW LED DRIVER AND THE POWER AND SIGNAL ENCLOSURE.

THE CONCEPTS EXPRESSED AND DETAILS SHOWN ON THIS DRAWING ARE CONFIDENTIAL AND PROPRIETARY. DO NOT REPRODUCE BY ANY MEANS, INCLUDING ELECTRONICALLY WITHOUT THE EXPRESSED WRITTEN CONSENT OF DAKTRONICS, INC. COPYRIGHT 2005 DAKTRONICS, INC.			
DAKTRONICS, INC. BROOKINGS, SD 57006			
PROJ: OUTDOOR LED SCOREBOARDS			
TITLE: COMPONENT LOCATIONS; SO-2008-11/-21, G3, FD			
DES. BY: CCAIN		DRAWN BY: CCAIN	
		DATE: 09 MAR 05	
REVISION	APPR. BY:	1192-R08A-236233	
00	SCALE: 1=30		

REV.	DATE	DESCRIPTION	BY	APPR.

BA-2010-11/-21, FD

ENCLOSED 16 COLUMN LED DRIVER AND POWER/SIGNAL ENCLOSURE.
(THE COVER HAS BEEN REMOVED TO SHOW THE COMPONENT DETAIL).

KNOCKOUTS FOR 1/2" CONDUIT

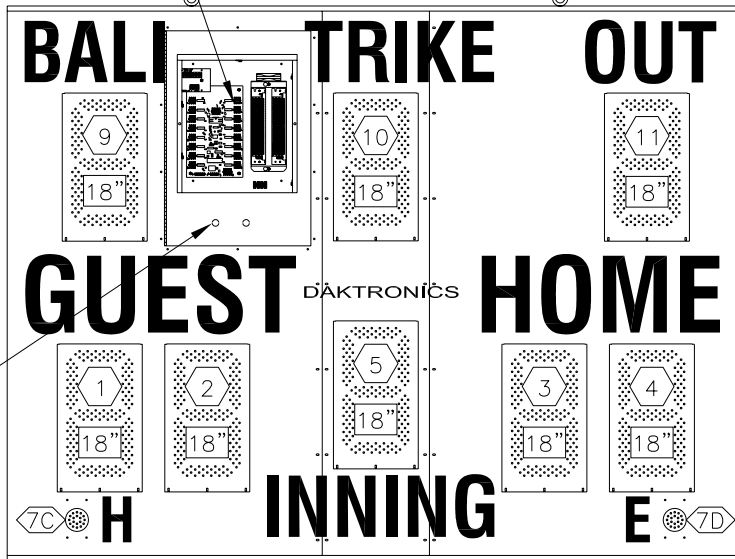

FRONT VIEW

- 5 = LED DRIVER CONNECTOR WIRED TO THAT DIGIT.
- 1C = LED DRIVER CONNECTOR AND SEGMENT (PIN) NO. WIRED TO THAT INDICATOR
- 18" = DIGIT SIZE

HINGED ACCESS DOORS REMOVED TO SHOW THE LED DRIVER AND POWER/SIGNAL ENCLOSURE.

THE CONCEPTS EXPRESSED AND DETAILS SHOWN ON THIS DRAWING ARE CONFIDENTIAL AND PROPRIETARY. DO NOT REPRODUCE BY ANY MEANS, INCLUDING ELECTRONICALLY WITHOUT THE EXPRESSED WRITTEN CONSENT OF DAKTRONICS, INC. COPYRIGHT 2002 DAKTRONICS, INC.			
DAKTRONICS, INC. BROOKINGS, SD 57006			
PROJ: OUTDOOR LED SCOREBOARDS			
TITLE: COMPONENT LOCATIONS; BA-2010-11/-21, G3			
DES. BY: CCAIN		DRAWN BY: CCAIN	
		DATE: 22 MAR 05	
REVISION	APPR. BY:	1192-R08A-237102	
00	SCALE: 1=25		

REV.	DATE	DESCRIPTION	BY	APPR.

ENCLOSED 16 COLUMN SLAVE DRIVER AND POWER/SIGNAL ENCLOSURE @2. (THE COVER HAS BEEN REMOVED TO SHOW THE COMPONENT DETAIL).

BA-2011-11/-21, FD

ENCLOSED 16 COLUMN MASTER DRIVER AND POWER/SIGNAL ENCLOSURE @2. (THE COVER HAS BEEN REMOVED TO SHOW THE COMPONENT DETAIL).

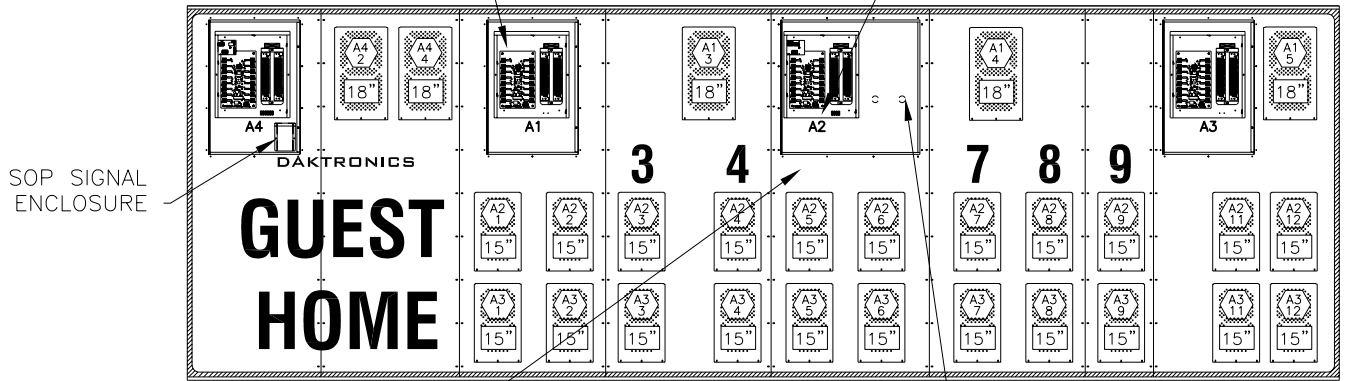

NOTE: SOME CAPTIONS HAVE BEEN REMOVED TO SHOW DETAIL

BA-2011-11/-21 W/ TNMC, FD

ENCLOSED 16 COLUMN SLAVE DRIVER AND POWER/SIGNAL ENCLOSURE @3. (THE COVER HAS BEEN REMOVED TO SHOW THE COMPONENT DETAIL).

ENCLOSED 16 COLUMN MASTER DRIVER AND POWER/SIGNAL ENCLOSURE @1. (THE COVER HAS BEEN REMOVED TO SHOW THE COMPONENT DETAIL).

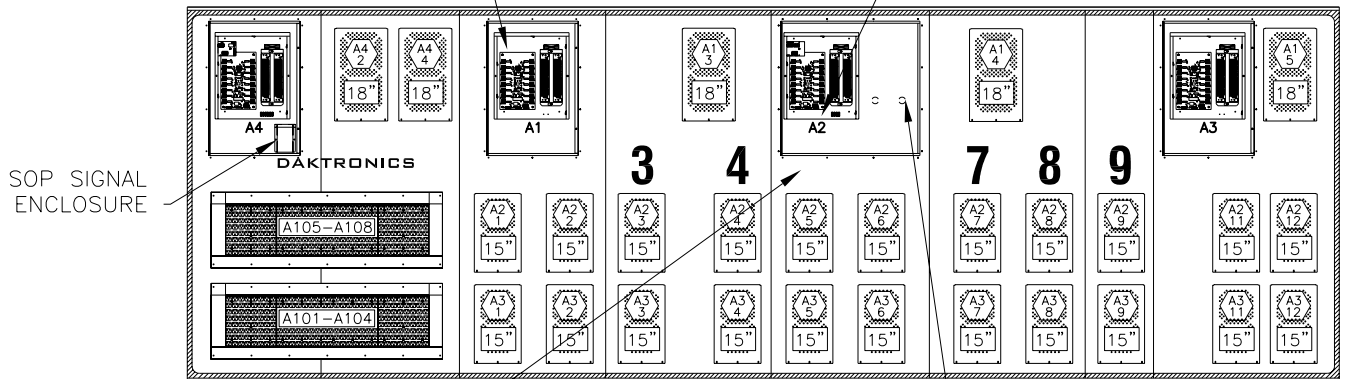

NOTE: SOME CAPTIONS HAVE BEEN REMOVED TO SHOW DETAIL

5 = LED DRIVER CONNECTOR WIRED TO THAT DIGIT.

18" = DIGIT SIZE

HINGED ACCESS DOORS REMOVED TO SHOW THE LED DRIVER AND THE POWER/SIGNAL ENCLOSURE.

THE CONCEPTS EXPRESSED AND DETAILS SHOWN ON THIS DRAWING ARE CONFIDENTIAL AND PROPRIETARY. DO NOT REPRODUCE BY ANY MEANS, INCLUDING ELECTRONICALLY WITHOUT THE EXPRESSED WRITTEN CONSENT OF DAKTRONICS, INC. COPYRIGHT 2002 DAKTRONICS, INC.			
DAKTRONICS, INC. BROOKINGS, SD 57006			
PROJ: OUTDOOR LED SCOREBOARDS			
TITLE: COMPONENT LOCATIONS; BA-2011-11/-21, G3			
DES. BY: CCAIN		DRAWN BY: CCAIN	
		DATE: 22 MAR 05	
REVISION	APPR. BY:	1192-R08A-237108	
00	SCALE: 1=40		

REV.	DATE	DESCRIPTION	BY	APPR.

ENCLOSED 16 COLUMN MASTER DRIVER AND POWER/SIGNAL ENCLOSURE @1. (THE COVER HAS BEEN REMOVED TO SHOW THE COMPONENT DETAIL).

BA-2014-11/-21, FD

ENCLOSED 16 COLUMN SLAVE DRIVER AND POWER/SIGNAL ENCLOSURE @2. (THE COVER HAS BEEN REMOVED TO SHOW THE COMPONENT DETAIL).

KNOCKOUTS FOR CONDUIT @2

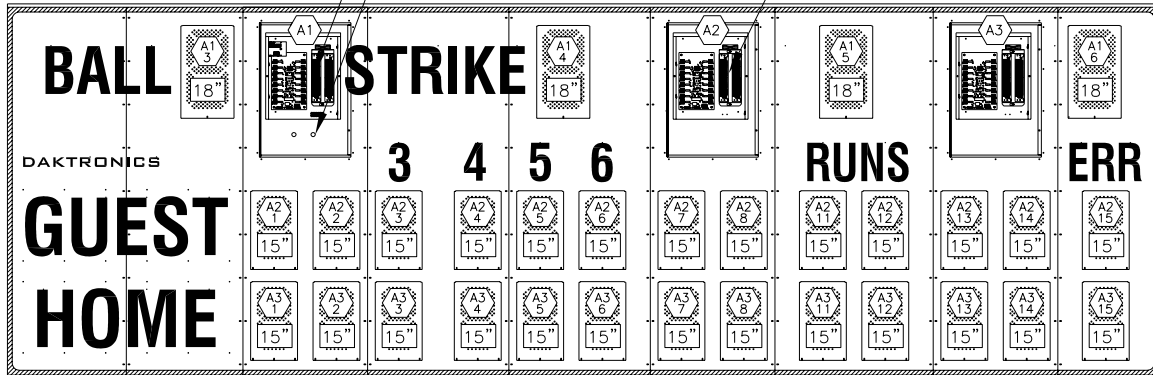

NOTE: SOME CAPTIONS HAVE BEEN REMOVED TO SHOW DETAIL.

FRONT VIEW

$A2_1$ = LED DRIVER CONNECTOR

18" = DIGIT SIZE

HINGED ACCESS DOORS REMOVED TO SHOW THE LED DRIVER AND THE POWER/SIGNAL ENCLOSURE.

THE CONCEPTS EXPRESSED AND DETAILS SHOWN ON THIS DRAWING ARE CONFIDENTIAL AND PROPRIETARY. DO NOT REPRODUCE BY ANY MEANS, INCLUDING ELECTRONICALLY WITHOUT THE EXPRESSED WRITTEN CONSENT OF DAKTRONICS, INC. COPYRIGHT 2004 DAKTRONICS, INC.

DAKTRONICS, INC. BROOKINGS, SD 57006

PROJ: OUTDOOR LED SCOREBOARDS

TITLE: COMPONENT LOCATIONS; BA-2014-11/-21, G3

DES. BY: MCOPLAN

DRAWN BY: MCOPLAN

DATE: 01JUL04

01	03 APR 07	CORRECTED DIGIT DESIGNATION FOR OUT, STRIKE BALL, AND H/E DIGITS.	MWM	
REV.	DATE	DESCRIPTION	BY	APPR.

REVISION	APPR. BY:
01	SCALE: 1=40

1192-R08A-237118

BA-2016-11/-21, FD

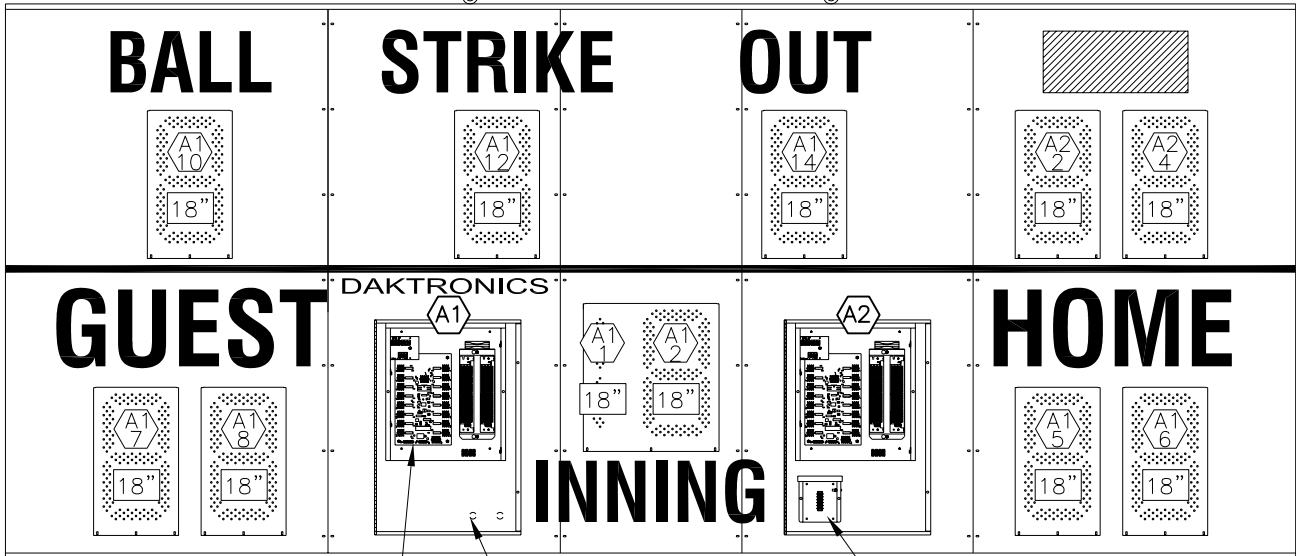

ENCLOSED 16 COLUMN LED DRIVER AND POWER/SIGNAL ENCLOSURE @2. (THE COVER HAS BEEN REMOVED TO SHOW THE COMPONENT DETAIL).

KNOCKOUTS FOR 1/2" CONDUIT

SOP/MPH/MPH SIGNAL/FIBER ENCLOSURE.

FRONT VIEW

A1 = LED DRIVER NUMBER
A5 = LED DRIVER CONNECTOR WIRED TO THAT DIGIT.

18" = DIGIT SIZE

HINGED ACCESS DOORS REMOVED TO SHOW THE LED DRIVER AND POWER/SIGNAL ENCLOSURE.

THE CONCEPTS EXPRESSED AND DETAILS SHOWN ON THIS DRAWING ARE CONFIDENTIAL AND PROPRIETARY. DO NOT REPRODUCE BY ANY MEANS, INCLUDING ELECTRONICALLY WITHOUT THE EXPRESSED WRITTEN CONSENT OF DAKTRONICS, INC. COPYRIGHT 2004 DAKTRONICS, INC.			
DAKTRONICS, INC. BROOKINGS, SD 57006			
PROJ: OUTDOOR LED SCOREBOARDS			
TITLE: COMPONENT LOCATIONS; BA-2016-11/-21, G3, FD			
DES. BY: CCAIN		DRAWN BY: CCAIN	DATE: 22 MAR 05
REVISION	APPR. BY:	1192-R08A-237124	
00	SCALE: 1=25		

REV.	DATE	DESCRIPTION	BY	APPR.

BA-2017-11/-21

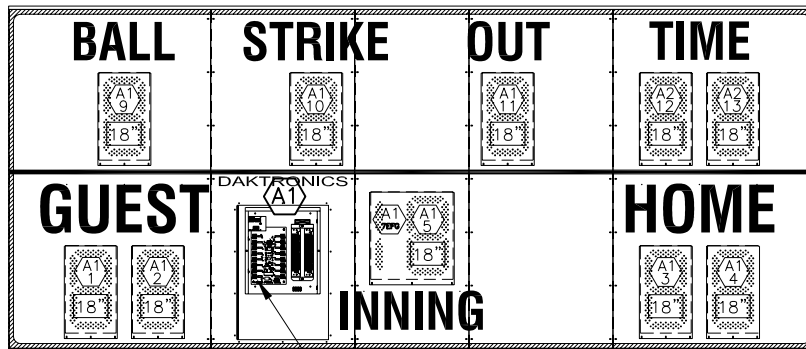

ENCLOSED 16 COLUMN MASTER DRIVER AND POWER/SIGNAL ENCLOSURE ©1. (THE COVER HAS BEEN REMOVED TO SHOW THE COMPONENT DETAIL).

FRONT VIEW

HINGED ACCESS DOORS REMOVED TO SHOW THE LED DRIVER AND THE POWER/SIGNAL ENCLOSURE.

18" = DIGIT SIZE

5 = LED DRIVER CONNECTOR

THE CONCEPTS EXPRESSED AND DETAILS SHOWN ON THIS DRAWING ARE CONFIDENTIAL AND PROPRIETARY. DO NOT REPRODUCE BY ANY MEANS, INCLUDING ELECTRONICALLY WITHOUT THE EXPRESSED WRITTEN CONSENT OF DAKTRONICS, INC. COPYRIGHT 2005 DAKTRONICS, INC.			
DAKTRONICS, INC. BROOKINGS, SD 57006			
PROJ: OUTDOOR LED SCOREBOARDS			
TITLE: COMPONENT LOCATIONS; BA-2017-11/-21, FD, G3			
DES. BY: CCAIN		DRAWN BY: CCAIN	DATE: 09 MAY 05
REVISION	APPR. BY:	1192-R08A-239729	
00	SCALE: 1=40		

REV.	DATE	DESCRIPTION	BY	APPR.
------	------	-------------	----	-------

MS-2012-11/-21

KNOCKOUT FOR 1/2" CONDUIT

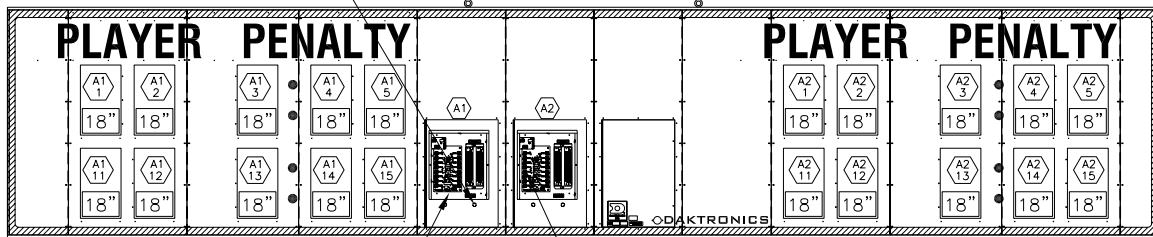

ENCLOSED 16 COLUMN MASTER LED DRIVER AND POWER/SIGNAL ENCLOSURE. (THE COVER HAS BEEN REMOVED TO SHOW THE ENCLOSURE COMPONENT DETAIL.)

ENCLOSED 16 COLUMN SLAVE LED DRIVER AND POWER/SIGNAL ENCLOSURE. (THE COVER HAS BEEN REMOVED TO SHOW THE ENCLOSURE COMPONENT DETAIL.)

FRONT VIEW

 = LED DRIVER NUMBER & LED DRIVER CONNECTOR WIRED TO THAT DIGIT.

 = DIGIT SIZE

HINGED ACCESS DOORS REMOVED TO SHOW THE LED DRIVER AND THE POWER/SIGNAL ENCLOSURE.

THE CONCEPTS EXPRESSED AND DETAILS SHOWN ON THIS DRAWING ARE CONFIDENTIAL AND PROPRIETARY. DO NOT REPRODUCE BY ANY MEANS, INCLUDING ELECTRONICALLY WITHOUT THE EXPRESSED WRITTEN CONSENT OF DAKTRONICS, INC. COPYRIGHT 2005 DAKTRONICS, INC.

DAKTRONICS, INC. BROOKINGS, SD 57006

PROJ: OUTDOOR LED SCOREBOARDS

TITLE: COMPONET LOCATIONS, MS-2012-11/21, FD

DES. BY: CCAIN

DRAWN BY: CCAIN

DATE: 25 JUL 05

REV.	DATE	DESCRIPTION	BY	APPR.
00				

REVISION

APPR. BY:

00

SCALE: 1=50

1192-R08A-246786

CR-2003-11/-21

ENCLOSED 16 COLUMN MASTER LED DRIVER AND POWER/SIGNAL ENCLOSURE.

KNOCKOUT FOR 1/2" CONDUIT

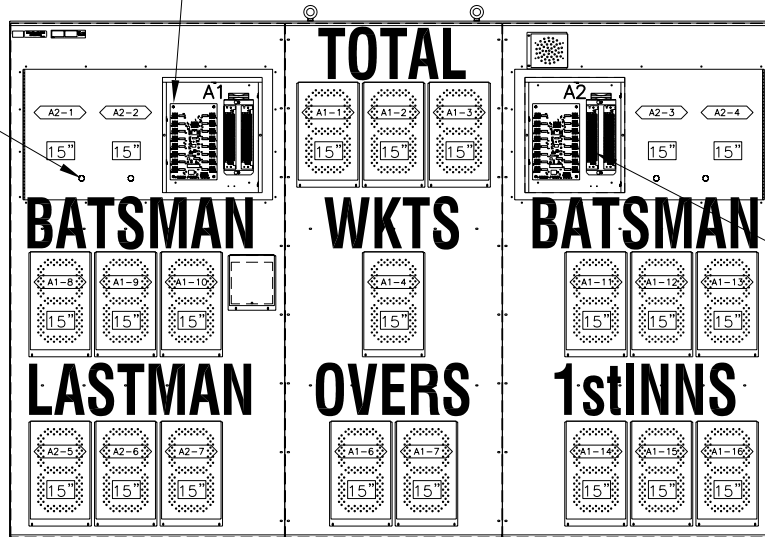

ENCLOSED 16 COLUMN SLAVE LED DRIVER AND POWER/SIGNAL ENCLOSURE.

FRONT VIEW

◁ A1-6 ▷ = LED DRIVER CONNECTOR AND SEGMENT (PIN) NO.

18" = DIGIT SIZE

HINGED ACCESS DOORS REMOVED TO SHOW THE LED DRIVER AND POWER/SIGNAL ENCLOSURE.

THE CONCEPTS EXPRESSED AND DETAILS SHOWN ON THIS DRAWING ARE CONFIDENTIAL AND PROPRIETARY. DO NOT REPRODUCE BY ANY MEANS, INCLUDING ELECTRONICALLY WITHOUT THE EXPRESSED WRITTEN CONSENT OF DAKTRONICS, INC. COPYRIGHT 2005 DAKTRONICS, INC.

DAKTRONICS, INC. BROOKINGS, SD 57006

PROJ: OUTDOOR LED CRICKET

TITLE: COMP LOCATION; CR-2003-11/21

DES. BY: CCAIN

DRAWN BY: CCAIN

DATE: 25 JUL 05

REVISION

APPR. BY:

00

SCALE: 1=30

1344-E10A-248722

REV.	DATE	DESCRIPTION	BY	APPR.

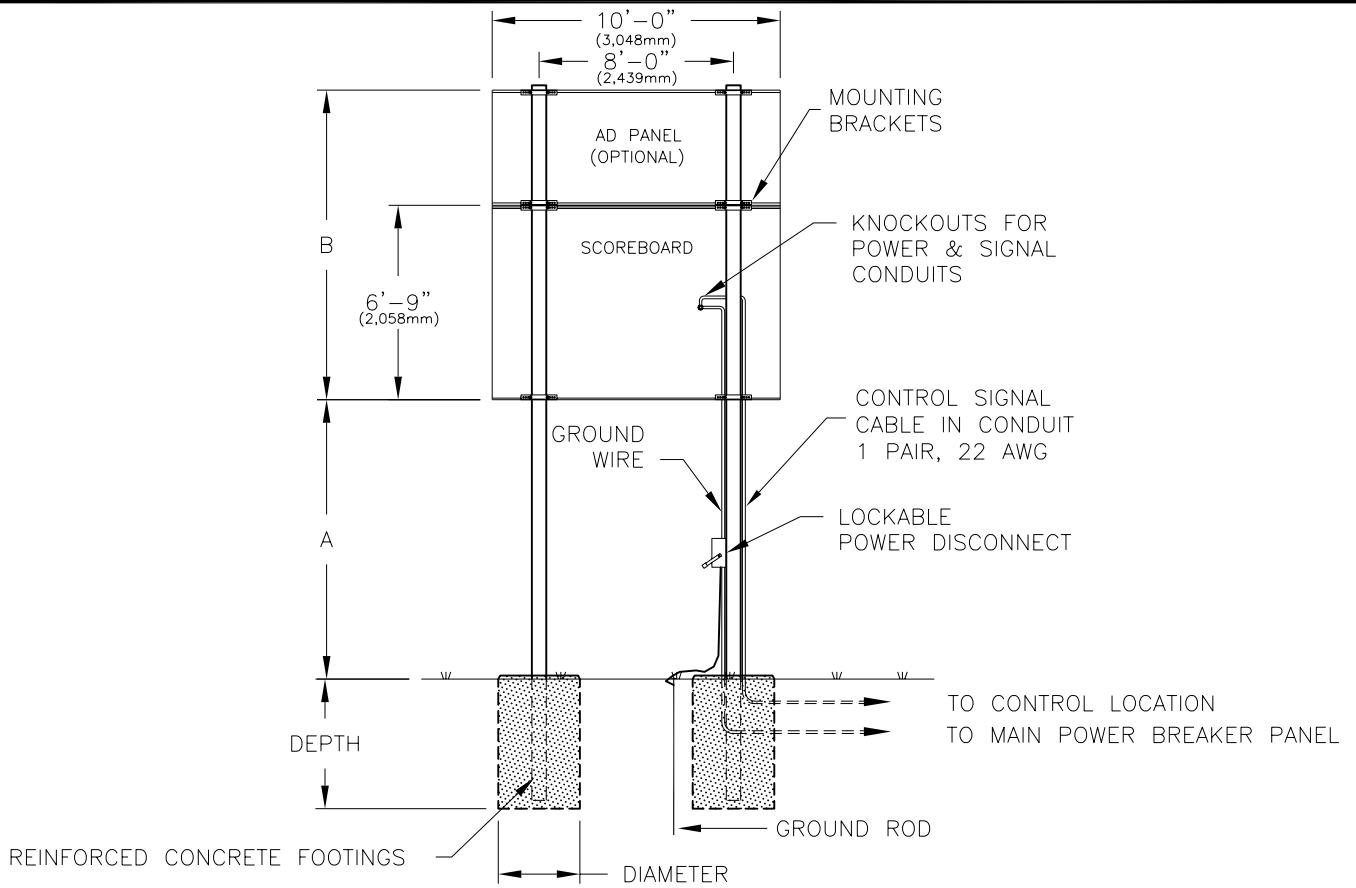

REAR VIEW
CR-2003

ELECTRICAL

POWER CABLE MUST HAVE A SEPERATE GROUND CONDUCTOR. SCOREBOARD MUST BE CONNECTED TO A GROUND ROD AT SCOREBOARD LOCATION.

FOOTING DIMENSIONS ARE SUGGESTIONS ONLY, PROVIDED TO ASSIST WITH ESTIMATING INSTALLATION COSTS, AND ARE NOT INTENDED FOR CONSTRUCTION PURPOSES.

COLUMNS AND FOOTINGS MUST BE DESIGNED BY A STATE LICENCED ENGINEER. DAKTRONICS DOES NOT ASSUME ANY LIABILITY FOR ANY INSTALLATIONS DERIVED FROM THIS INFORMATION OR DESIGNED AND INSTALLED BY OTHERS.

MODEL CR-2003						
VERTICAL DISTANCE (A)	AD PANEL HEIGHT	COMBINED HEIGHT (B)		DESIGN WIND VELOCITY		
				70 MPH	80 MPH	100 MPH
10 FT	NONE	6'-9"	BEAM	W6x15	W6x15	W6x20
			FOOTING	3.0' x 5.0'	3.0' x 5.5'	3.0' x 6.5'
	4 FT	10'-9"	BEAM	W6x20	W8x24	W8x28
			FOOTING	3.0' x 6.0'	3.0' x 6.5'	3.0' x 7.5'
12 FT	NONE	6'-9"	BEAM	W8x18	W8x18	W8x24
			FOOTING	3.0' x 5.5'	3.0' x 6.0'	3.0' x 7.0'
	4 FT	10'-9"	BEAM	W18x24	W12x26	W8x31
			FOOTING	3.0' x 6.5'	3.0' x 7.0'	3.0' x 8.0'
14 FT	NONE	6'-9"	BEAM	W6x20	W6x20	W12x26
			FOOTING	3.0' x 5.5'	3.0' x 6.0'	3.0' x 7.0'
	4 FT	10'-9"	BEAM	W12x26	W12x30	W10x33
			FOOTING	3.0' x 6.5'	3.0' x 7.5'	3.0' x 8.5'

FOOTING = DIAMETER X DEPTH

A NOTE ABOUT BEAM NOMENCLATURE:

For a typical beam, W12x30 for example, "W" stands for "Wide-Flange Beam". The first number (12) is the approximate front to rear dimension of the beam in inches. The second number (30) is the weight per foot in pounds. This numbering is standard in the steel industry. Widths vary from 4 to 8 inches in this chart.

DAKTRONICS, INC. BROOKINGS, SD 57006			
PROJ: OUTDOOR LED CRICKET			
TITLE: INSTALLATION SPECIFICATIONS, CR-2003			
DES. BY:	DRAWN BY: CCAIN	DATE: 26 JUL 05	
REVISION	APPR. BY:	1344-E10A-248966	
01	SCALE: 1=80		

01	25 OCT 07	ADDED MILLIMETERS DIMENSIONS	KDD	
REV.	DATE	DESCRIPTION	BY	APPR.

- 0A-1192-3165 8X32 34MM AMBER TNMC G4
- 0A-1192-3167 8X48 34MM AMBER TNMC G4
- 0A-1192-XXX 8X64 34MM AMBER TNMC G4
- 0A-1192-3229 8X32 34MM DROP IN/RETROFIT TNMC G4
- 0A-1192-3231 8X48 34MM DROP IN/RETROFIT TNMC G4
- 0A-1192-XXXX 8X64 34MM DROP IN/RETROFIT TNMC G4

W-1387, 18" RIBBON CABLE
TYP. FOR ALL MODULE TO
MODULE CONNECTIONS

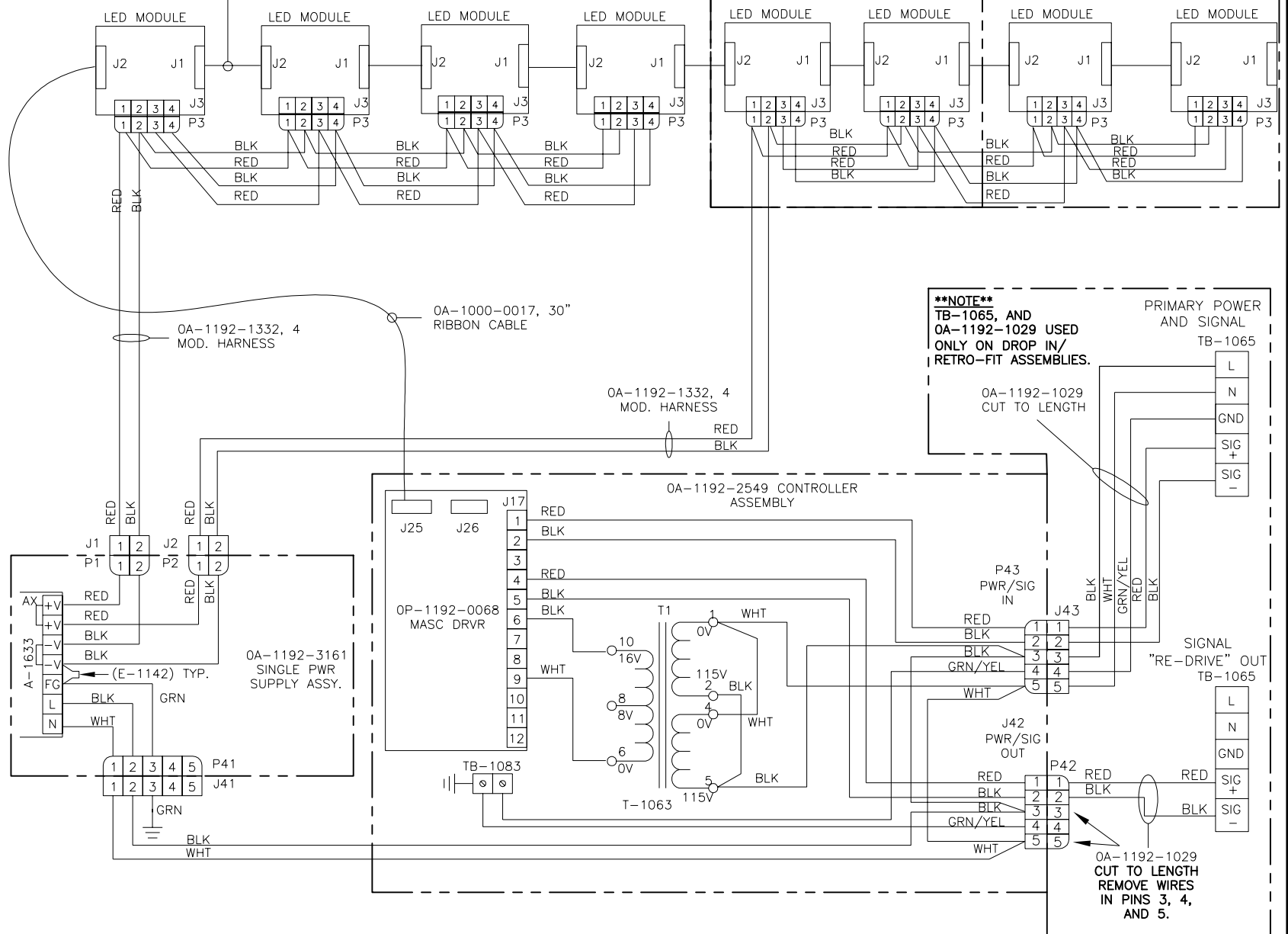

****NOTE****
TB-1065, AND
OA-1192-1029 USED
ONLY ON DROP IN/
RETRO-FIT ASSEMBLIES.

REV.	DATE	DESCRIPTION	BY	APPR.
01	DEC 05	CHANGED MOD. PWR HARNESS FROM 2 PIN TO 4 PIN HARNESS	SJC	
02	FEB 06	UPDATED PART NUMBERS AND EXPANDED DRAWING TO COVER 8X64 OPTION	MMM	
03	NOV 06	UPDATED TITLE TO INCLUDE 34 MM	SAL	MMM
04	APR 07	ADDED TB-1083 GND TERMINAL BLOCK AND GROUND WIRES	DMD	

THE CONCEPTS EXPRESSED AND DETAILS SHOWN ON THIS DRAWING ARE CONFIDENTIAL AND PROPRIETARY. DO NOT REPRODUCE BY ANY MEANS, INCLUDING ELECTRONICALLY WITHOUT THE EXPRESSED WRITTEN CONSENT OF DAKTRONICS, INC. COPYRIGHT 2005 DAKTRONICS, INC.

PROJ: OUTDOOR LED DIGIT SCOREBOARDS
TITLE: SCHEMATIC; 34 MM AMBER TNMC GEN IV
DES. BY: MILLER
DRAWN BY: DINING
DATE: 31 AUG 05

REVISION 04
SCALE: NONE
1192-R01A-252645

DAKTRONICS, INC. BROOKINGS, SD 57006

- 0A-1192-3164 8X32 34MM RED TNMC G4
- 0A-1192-3166 8X48 34MM RED TNMC G4
- 0A-1192-XXX 8X64 34MM RED TNMC G4
- 0A-1192-3228 8X32 34MM DROP IN/RETROFIT TNMC G4
- 0A-1192-3230 8X48 34MM DROP IN/RETROFIT TNMC G4
- 0A-1192-XXXX 8X64 34MM DROP IN TNMC G4

W-1387, 18" RIBBON CABLE
TYP. FOR ALL MODULE TO
MODULE CONNECTIONS

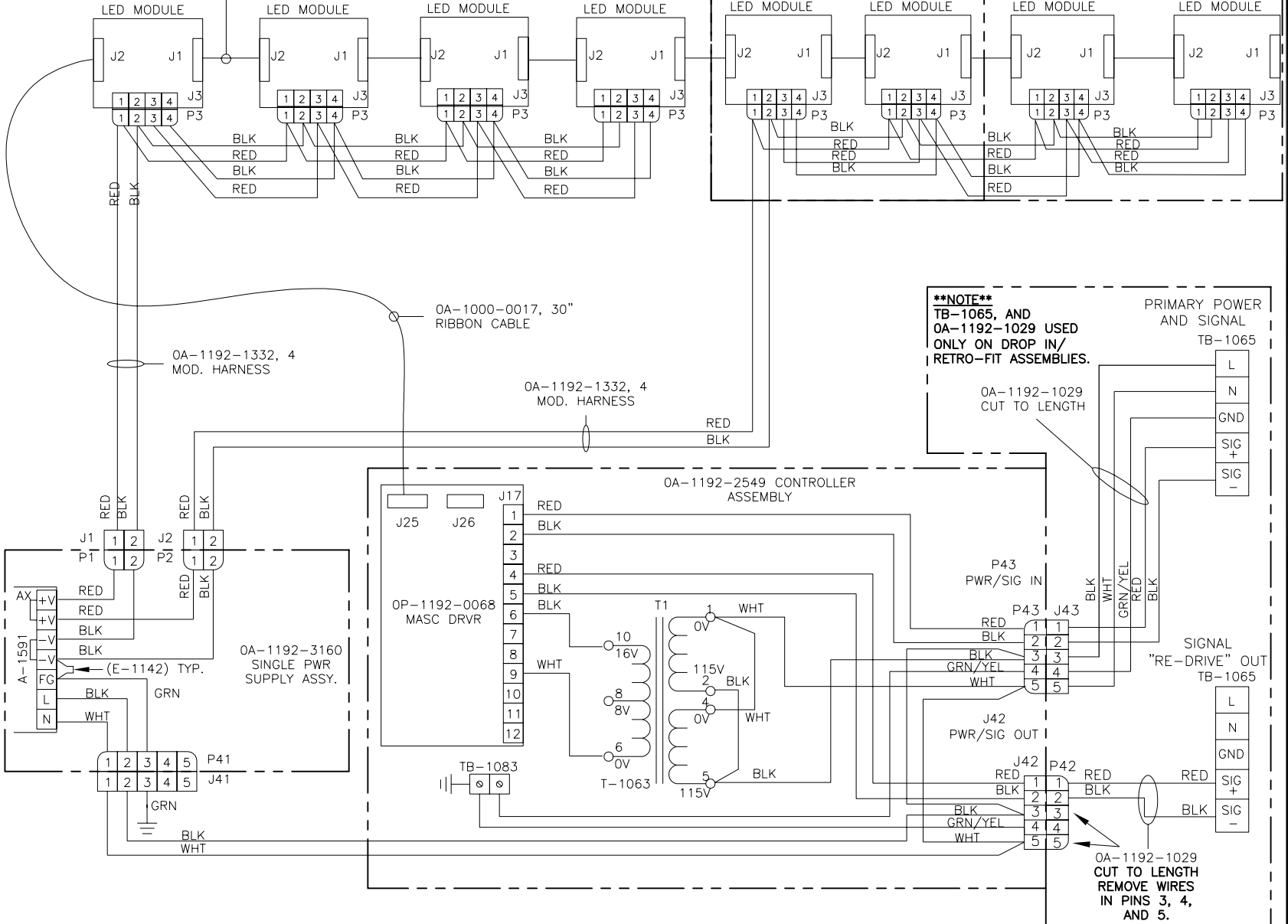

****NOTE****
TB-1065, AND
OA-1192-1029 USED
ONLY ON DROP IN/
RETRO-FIT ASSEMBLIES.

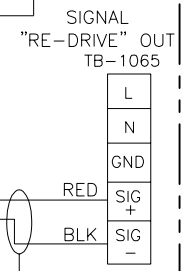
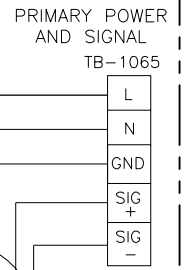

OA-1192-1029
CUT TO LENGTH
REMOVE WIRES
IN PINS 3, 4,
AND 5.

04	09 APR 07	ADDED TB-1063 AND GND ON J42, & P43	DMD	APPR.
03	07 NOV 06	UPDATED TITLE TO INCLUDE 34 MM	SAL	
02	08 MAR 06	UPDATED DETAILS TO SHOW 64 LONG	MMM	
01	01 DEC 05	CHANGE POWER HARNESS TO MOD FROM 2 PIN TO 4 PIN	SJC	
REV.	DATE	DESCRIPTION	BY	

THE CONCEPTS EXPRESSED AND DETAILS SHOWN ON THIS DRAWING ARE CONFIDENTIAL AND PROPRIETARY. DO NOT REPRODUCE BY ANY MEANS, INCLUDING ELECTRONICALLY WITHOUT THE EXPRESSED WRITTEN CONSENT OF DAKTRONICS, INC. COPYRIGHT 2005 DAKTRONICS, INC.

PROJ: OUTDOOR LED SCOREBOARDS
DAKTRONICS, INC. BROOKINGS, SD 57006

TITLE: SCHEMATIC; 34 MM RED TNMC GEN IV

DES. BY: DRAWN BY: DDINING DATE: 30 AUG 05

REVISION APPR. BY: SCALE: 1192-R01A-252681

REV.	01	DATE	20 DEC 07	DESCRIPTION	UPDATED DRAWING TO SHOW 864 TNMC MODELS.	BY	MMM	APPR.
------	----	------	-----------	-------------	--	----	-----	-------

832 AMBER LED TNMC
OA-1192-3165

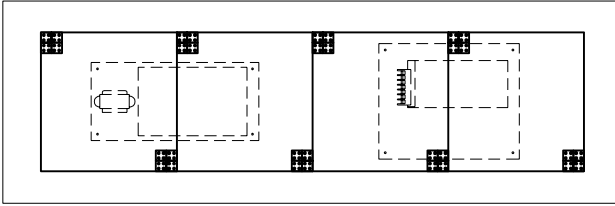

848 AMBER LED TNMC
OA-1192-3166

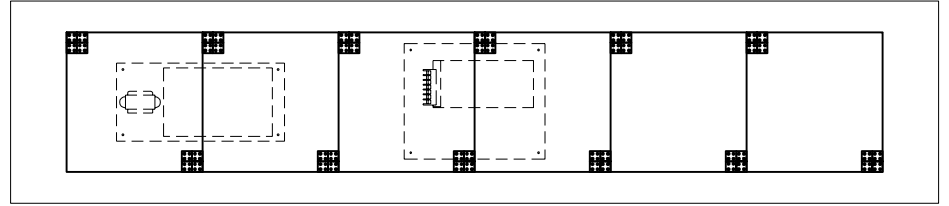

832 RED LED TNMC
OA-1192-3164

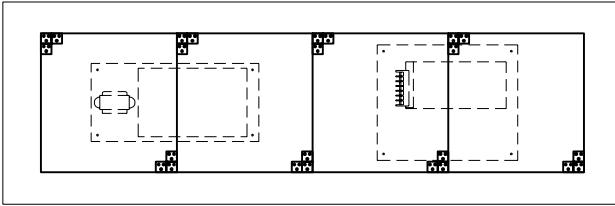

848 RED LED TNMC
OA-1192-3167

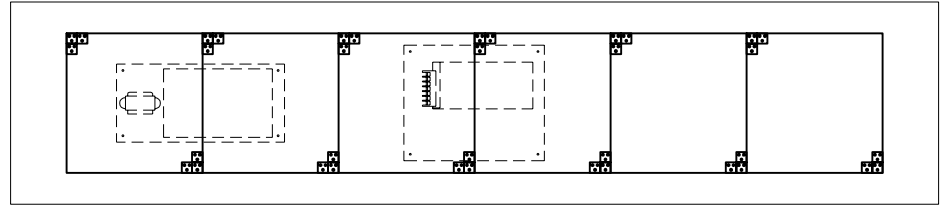

864 AMBER LED TNMC
OA-1192-3295

864 RED LED TNMC
OA-1192-3294

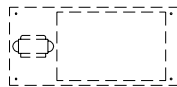
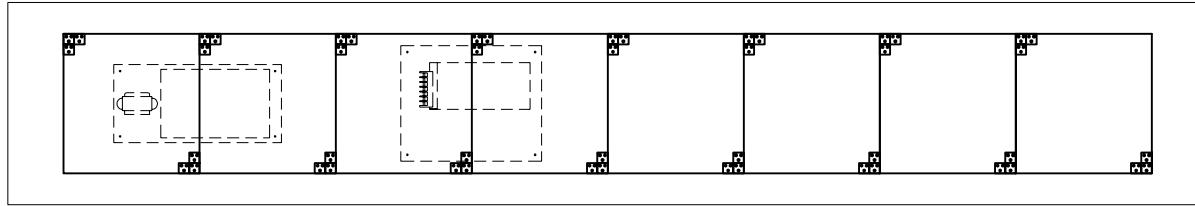

TNMC CONTROLLER
OA-1192-2549

USED IN RED & AMBER LED TNMCs

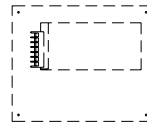

SINGLE POWER SUPPLY ASSEMBLY
OA-1192-3161

USED IN AMBER LED TNMCs

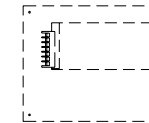

SINGLE POWER SUPPLY ASSEMBLY
OA-1192-3160

USED IN RED LED TNMCs

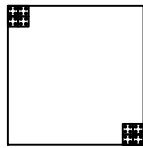

AMBER LED TNMC MODULE
OA-1208-4001
USED IN AMBER LED TNMCs

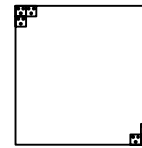

RED LED TNMC MODULE
OA-1208-4000
USED IN RED LED TNMCs

THE CONCEPTS EXPRESSED AND DETAILS SHOWN ON THIS DRAWING ARE CONFIDENTIAL AND PROPRIETARY. DO NOT REPRODUCE BY ANY MEANS, INCLUDING ELECTRONICALLY WITHOUT THE EXPRESSED WRITTEN CONSENT OF DAKTRONICS, INC. COPYRIGHT 2003 DAKTRONICS, INC.

DAKTRONICS, INC. BROOKINGS, SD 57006

PROJ.: OUTDOOR LED SCOREBOARDS

TITLE: COMPONENT LOC.: 832/842/864 RED/AMB LED TNMC G4

DES. BY: KBRICKER DRAWN BY: KBRICKER DATE: 08NOV05

REVISION 01 APPR. BY: SCALE: 1=15 1192-R08A-257029

BA-2019-11/-21

ENCLOSED 16 COLUMN LED DRIVER AND POWER/SIGNAL ENCLOSURE. (THE COVER HAS BEEN REMOVED TO SHOW THE COMPONENT DETAIL).

KNOCKOUTS FOR 1/2" CONDUIT

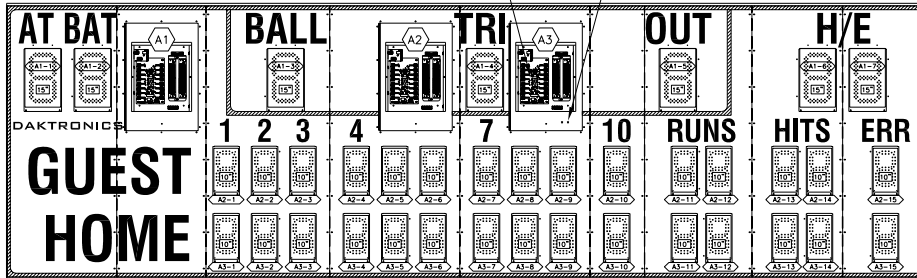

BA-2019-11/-21 W/ TNMC

ENCLOSED 16 COLUMN LED DRIVER AND POWER/SIGNAL ENCLOSURE. (THE COVER HAS BEEN REMOVED TO SHOW THE COMPONENT DETAIL).

KNOCKOUTS FOR 1/2" CONDUIT

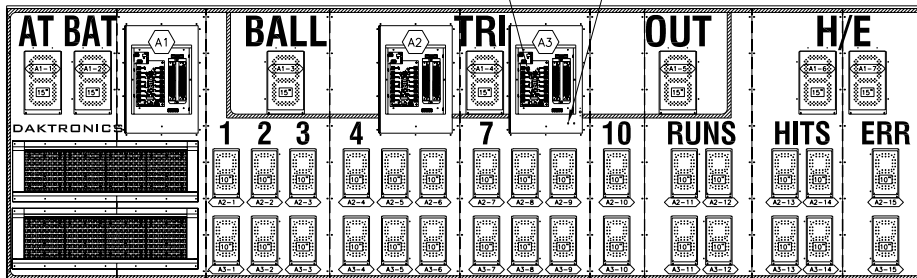

◁ A2-1 ▷ = DRIVER #; DRIVER PLUG #

18" = DIGIT SIZE

HINGED ACCESS DOORS REMOVED TO SHOW THE LED DRIVER AND POWER/SIGNAL ENCLOSURE.

THE CONCEPTS EXPRESSED AND DETAILS SHOWN ON THIS DRAWING ARE CONFIDENTIAL AND PROPRIETARY. DO NOT REPRODUCE BY ANY MEANS, INCLUDING ELECTRONICALLY WITHOUT THE EXPRESSED WRITTEN CONSENT OF DAKTRONICS, INC. COPYRIGHT 2005 DAKTRONICS, INC.

DAKTRONICS, INC. BROOKINGS, SD 57006

PROJ: OUTDOOR LED SCOREBOARDS

TITLE: COMPONENT LOCATIONS; BA-2019-11/21

DES. BY: CCAIN

DRAWN BY: CCAIN

DATE: 28 DEC 05

REVISION

APPR. BY:

00

SCALE: 1=50

1192-R08A-260481

REV.	DATE	DESCRIPTION	BY	APPR.

02	3 OCT 06	ADDED HARNESS 0A-1192-4262	CUG		
01	18 JUL 06	ADDED HARNESS NUMBERS TO POWER SUPPLY DETAIL.	BLC		
REV.	DATE	DESCRIPTION	BY	APPR.	

PROJ: OUTDOOR LED		TITLE: SCHEMATIC; 60" LED CLOCK	
DES. BY:		DRAWN BY: DDINING	DATE: 5 JUN 06
REVISION	APPR. BY: MILLER	SCALE: NONE	1192-R01A-273885
02			

THE CONCEPTS EXPRESSED AND DETAILS SHOWN ON THIS DRAWING ARE CONFIDENTIAL AND PROPRIETARY. DO NOT REPRODUCE BY ANY MEANS, INCLUDING ELECTRONICALLY WITHOUT THE EXPRESSED WRITTEN CONSENT OF DAKTRONICS, INC. COPYRIGHT 2006 DAKTRONICS, INC.

DAKTRONICS, INC. BROOKINGS, SD 57006

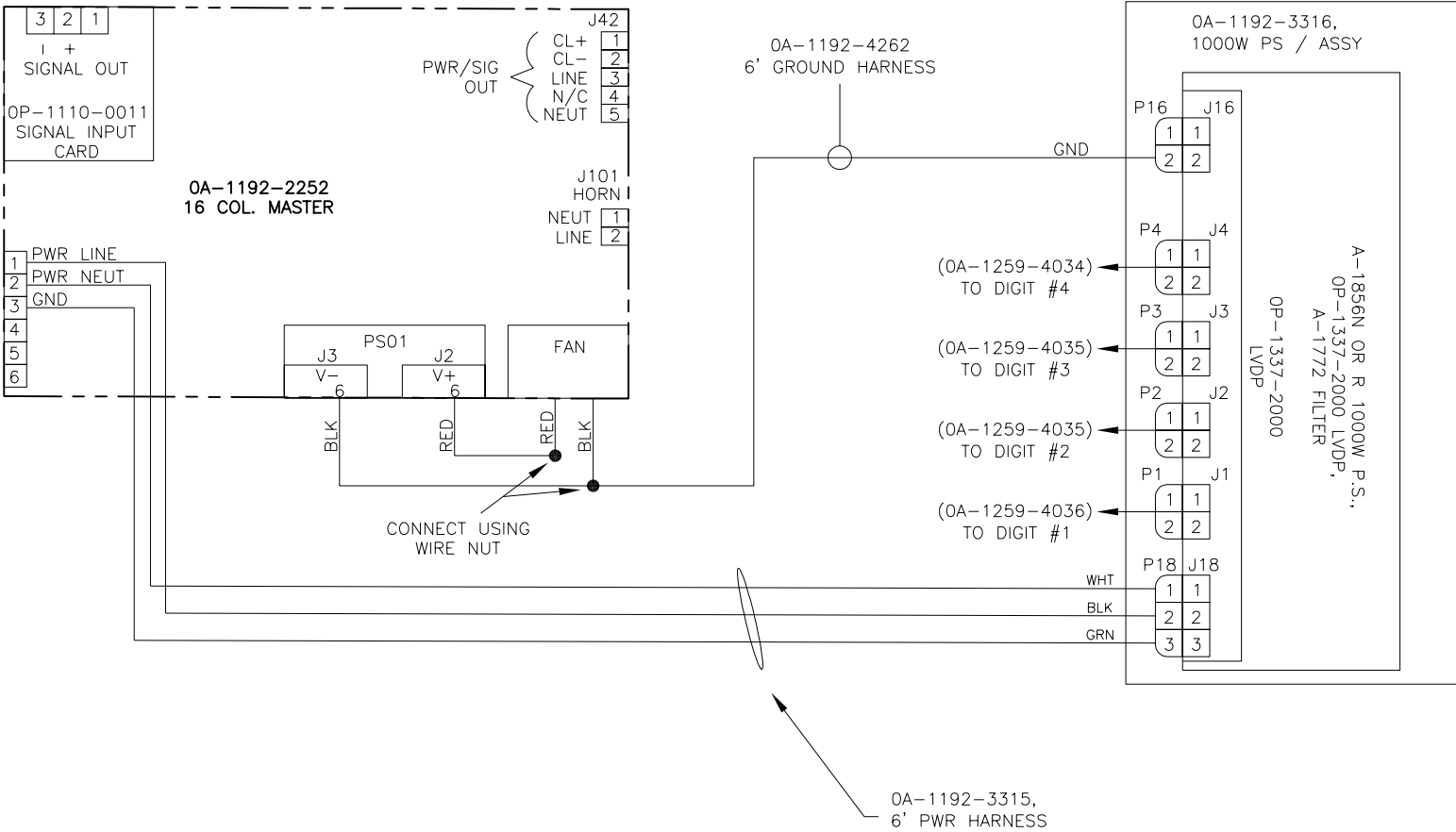

DAKTRONICS, INC. BROOKINGS, SD 57006

REV.	DATE	DESCRIPTION	BY	APPR.
------	------	-------------	----	-------

FB-2410-11/-21

OPTIONAL 120V OR 12V HORN

OPTIONAL RADIO RECEIVER

ENCLOSED 16 COLUMN MASTER DRIVER @1.

1000W POWER SUPPLY

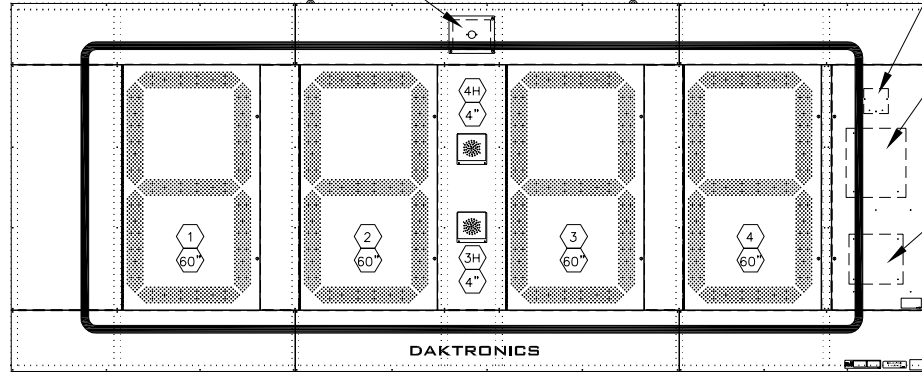

FRONT VIEW

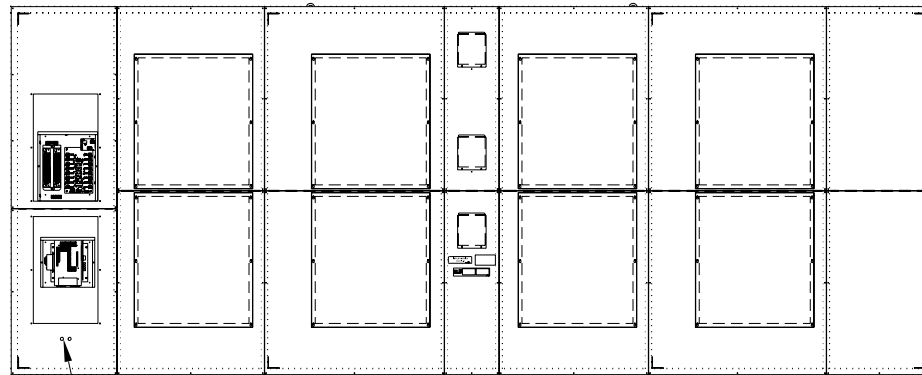

KNOCKOUTS FOR
1/2" CONDUIT.

REAR VIEW

REAR ACCESS COVERS REMOVED
TO SHOW THE LED DRIVER AND
THE POWER SUPPLY ENCLOSURES.

1 = LED DRIVER CONNECTOR
WIRED TO DIGIT.

60° = DIGIT SIZE

THE CONCEPTS EXPRESSED AND DETAILS SHOWN ON THIS DRAWING ARE CONFIDENTIAL AND PROPRIETARY. DO NOT REPRODUCE BY ANY MEANS, INCLUDING ELECTRONICALLY WITHOUT THE EXPRESSED WRITTEN CONSENT OF DAKTRONICS, INC. COPYRIGHT 2006 DAKTRONICS, INC.

PROJ: OUTDOOR LED SCOREBOARDS
DAKTRONICS, INC. BROOKINGS, SD 57006

TITLE: COMPONENT LOCATION: FB-2410
DES. BY: BCURTIS DRAWN BY: BCURTIS DATE: 14 JUN 06

REVISION 00 APPR. BY: SCALE: 1=50 1192-E07A-274863

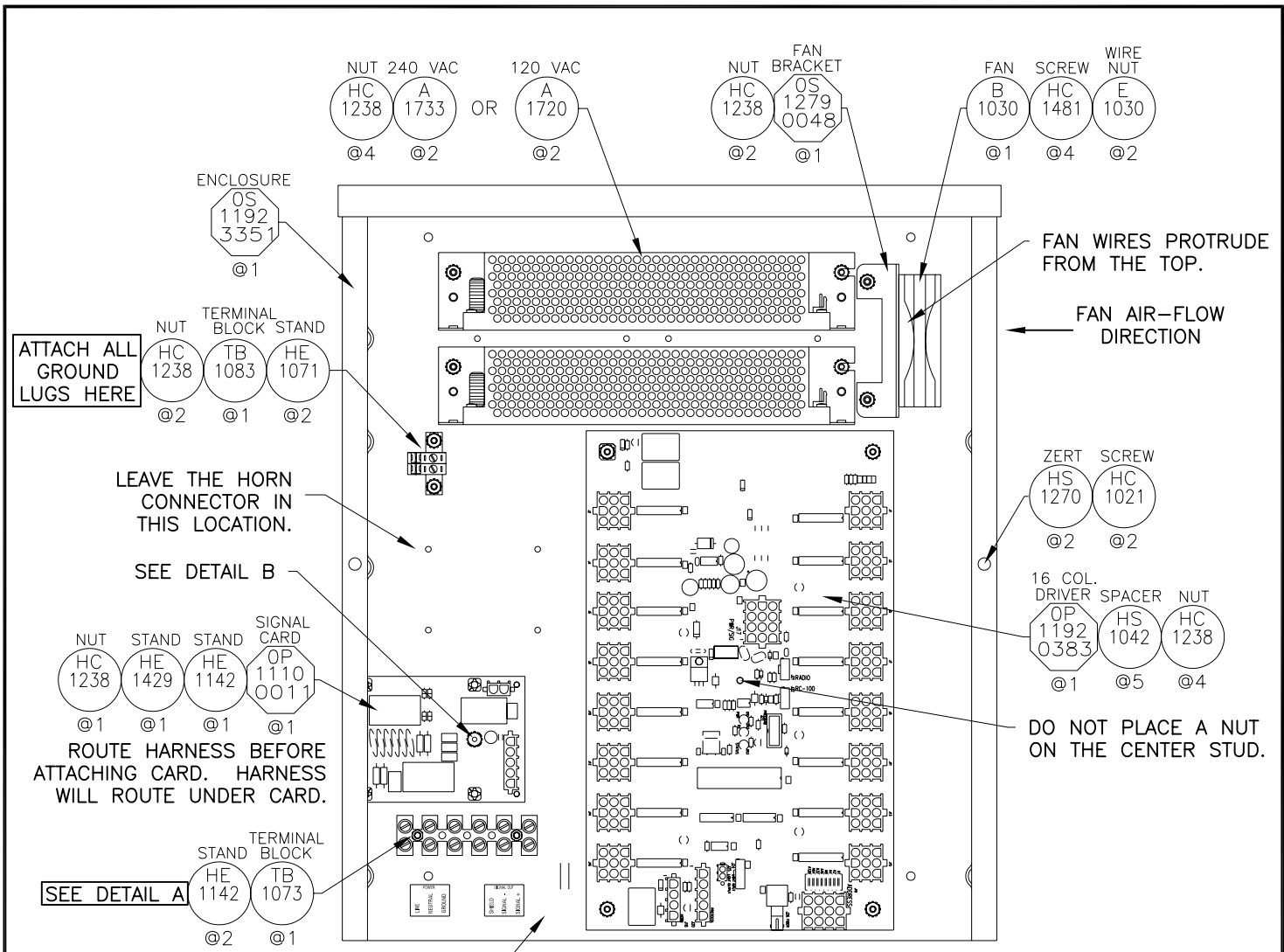

FRONT VIEW

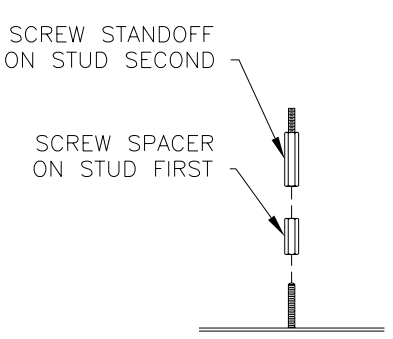
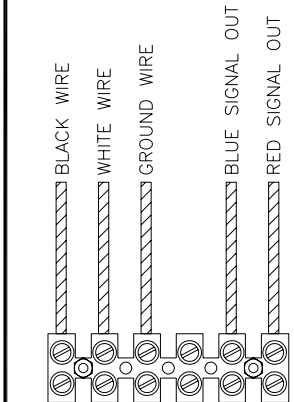

DETAIL: A
(SCALE 1=1.5)

DETAIL: B

NOTES:

- NOTE THE WIRES PROTRUDE FROM THE FAN ON ONE OF THE FOUR SIDES. WHEN MOUNTING THE FAN TO THE FAN BRACKET, MAKE SURE THE FAN WIRES PROTRUDE FROM THE TOP.
- THE FAN AIR-FLOW SHOULD BLOW AIR ONTO THE POWER SUPPLIES.
- SEE DRAWING A-284952 FOR COVER LABELING.

ASSEMBLY PACKETS

0A-1192-4252...DRIVER; GEN IV OUTDOOR LED, 16 COL MASTER
.OS-1192-3351...ENCLOSURE; GEN IV OUTDOOR LED DRIVER

REV.	DATE	DESCRIPTION	BY	APPR.
04	13 JUN 08	ADDED HE-1071 @2 PER ECO 049837	AMG	
03	04 DEC 07	REMOVED CABLE ANCHORS AND RIVETS.	BJC	
02	10 SEP 07	ADDED POWER LABEL BELOW TERMINAL BLOCK.	BJC	
01	12 MAR 07	ADDED SIGNAL OUT LABEL BELOW TERMINAL BLOCK FOR RE-DRIVE CAPABILITY.	BJC	

THE CONCEPTS EXPRESSED AND DETAILS SHOWN ON THIS DRAWING ARE CONFIDENTIAL AND PROPRIETARY. DO NOT REPRODUCE BY ANY MEANS, INCLUDING ELECTRONICALLY WITHOUT THE EXPRESSED WRITTEN CONSENT OF DAKTRONICS, INC. COPYRIGHT 2006 DAKTRONICS, INC.			
DAKTRONICS, INC. BROOKINGS, SD 57006			
PROJ: OUTDOOR LED SCOREBOARDS			
TITLE: DRIVER: GEN IV OUTDOOR LED- 16 COL MASTER			
DES. BY: BCURTIS		DRAWN BY: BCURTIS	DATE: 14 SEPT 06
REVISION	APPR. BY:	1192-E10A-284920	
06	SCALE: 1=4		

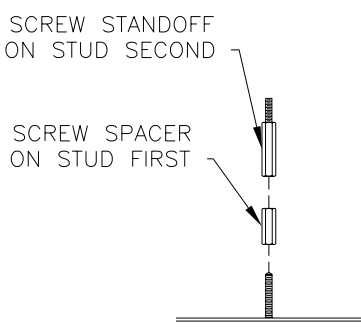
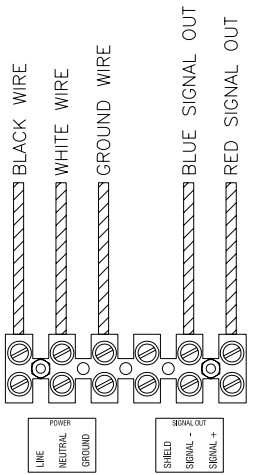
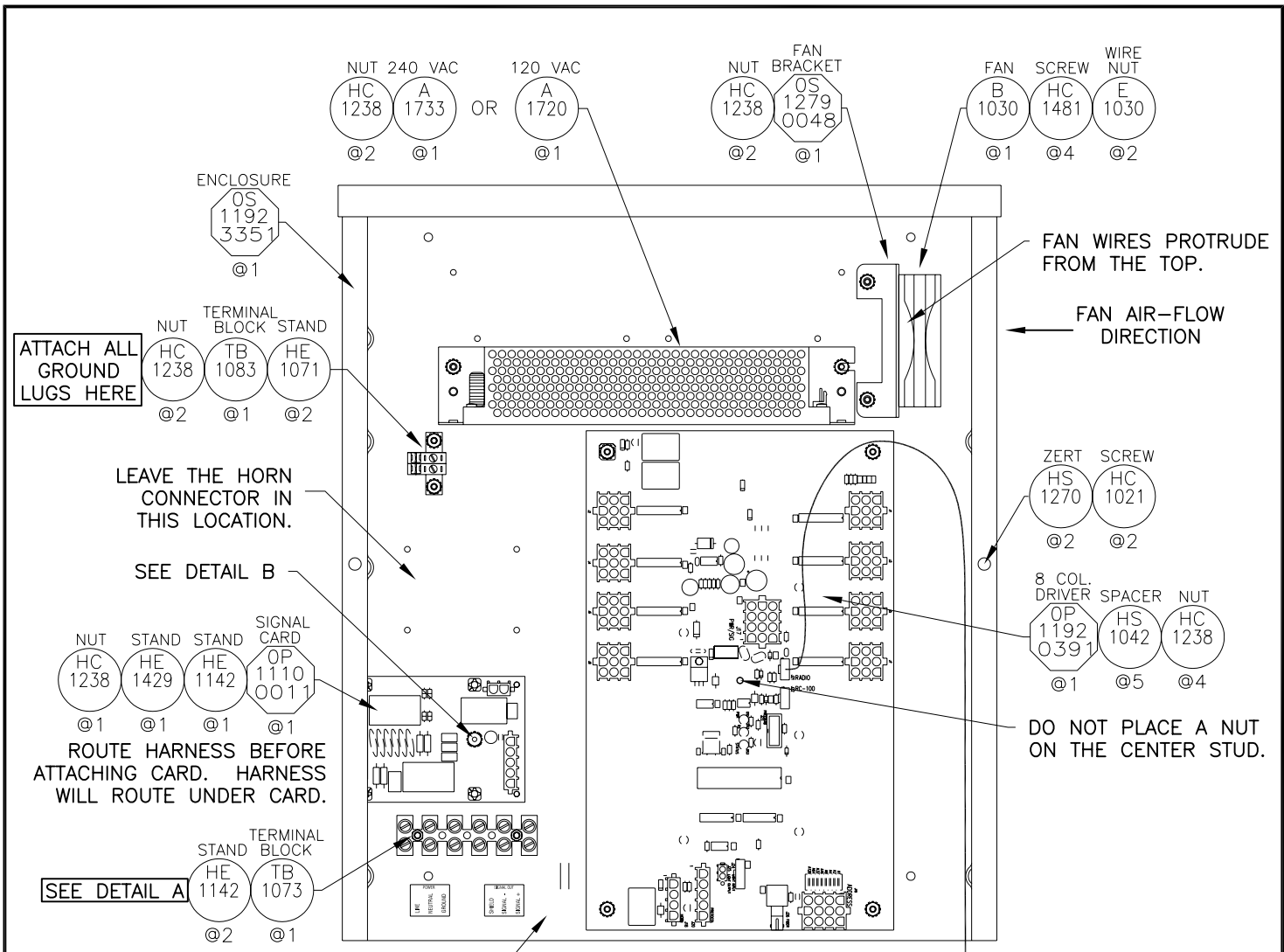

NOTES:

- NOTE THE WIRES PROTRUDE FROM THE FAN ON ONE OF THE FOUR SIDES. WHEN MOUNTING THE FAN TO THE FAN BRACKET, MAKE SURE THE FAN WIRES PROTRUDE FROM THE TOP.
- THE FAN AIR-FLOW SHOULD BLOW AIR ONTO THE POWER SUPPLIES.
- SEE DRAWING A-284952 FOR COVER LABELING.

ASSEMBLY PACKETS

0A-1192-4254...DRIVER; GEN IV OUTDOOR LED, 8 COL MASTER
 .OS-1192-3351...ENCLOSURE; GEN IV OUTDOOR LED DRIVER

DETAIL: A
 (SCALE 1=1.5)

DETAIL: B

REV.	DATE	DESCRIPTION	BY	APPR.
04	13 JUN 08	ADDED HE-1071 @2 PER ECO 049837	AMG	
03	04 DEC 07	REMOVED CABLE ANCHORS AND RIVETS.	BJC	
02	10 SEP 07	ADDED PWR/SIGNAL LABELS BELOW TERMINAL BLOCK.	BJC	
01	13 AUG 07	DDINING ADDED RADIO HARNESS 0A-1388-0004	DKD	

THE CONCEPTS EXPRESSED AND DETAILS SHOWN ON THIS DRAWING ARE CONFIDENTIAL AND PROPRIETARY. DO NOT REPRODUCE BY ANY MEANS, INCLUDING ELECTRONICALLY WITHOUT THE EXPRESSED WRITTEN CONSENT OF DAKTRONICS, INC. COPYRIGHT 2006 DAKTRONICS, INC.			
DAKTRONICS, INC. BROOKINGS, SD 57006			
PROJ: OUTDOOR LED SCOREBOARDS			
TITLE: DRIVER: GEN IV OUTDOOR LED- 8 COL MASTER			
DES. BY: BCURTIS		DRAWN BY: BCURTIS	DATE: 14 SEPT 06
REVISION	APPR. BY:	1192-E10A-284922	
05	SCALE: 1=4		

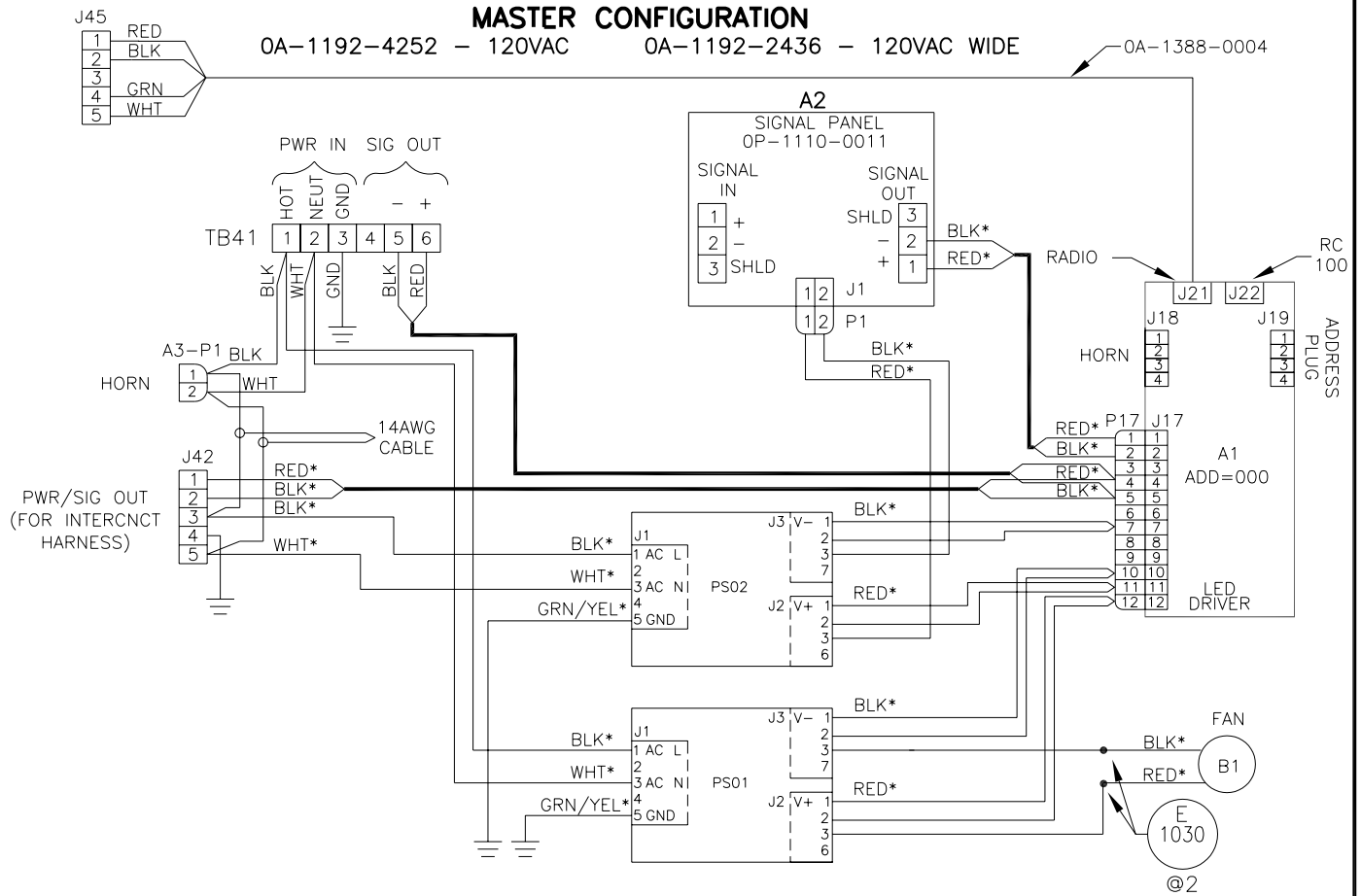

ALL CONDUCTORS ARE 14 AWG EXCEPT * INDICATES 18AWG CONDUCTORS.
ALL SIGNAL CONDUCTORS ARE ALSO 18 AWG CONDUCTORS.

REFERENCE DWG 1192-R03C-285776 FOR DETAILED CABLE ASSEMBLY DIAGRAM.

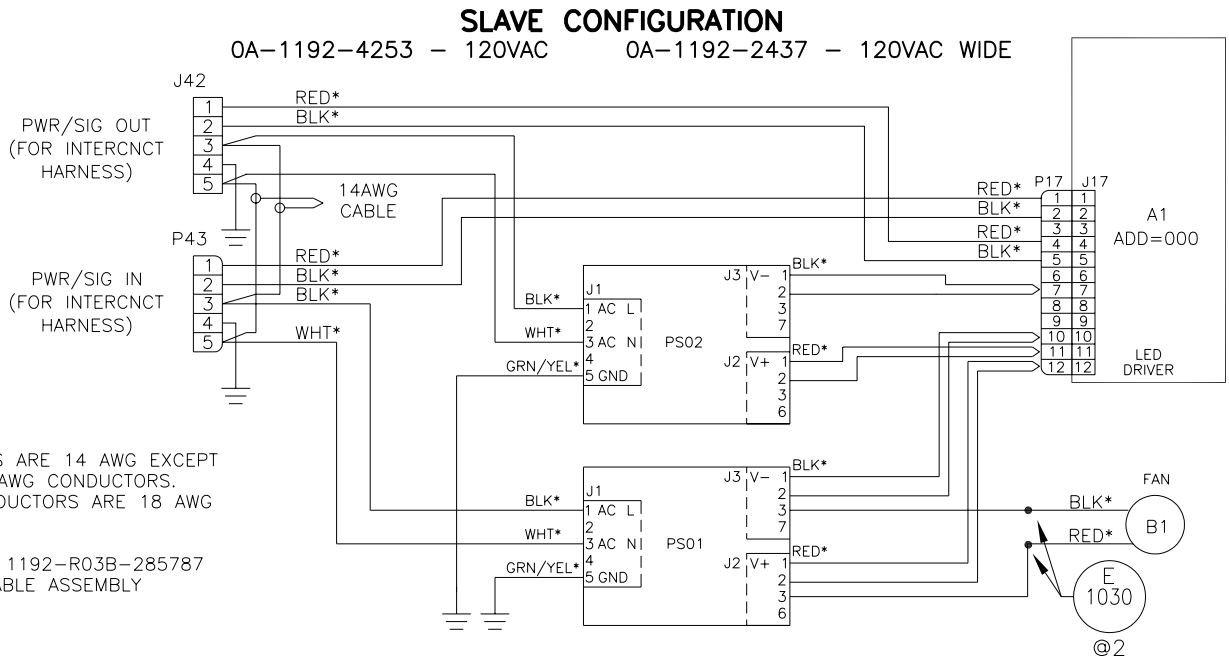

ALL CONDUCTORS ARE 14 AWG EXCEPT * INDICATES 18 AWG CONDUCTORS.
ALL SIGNAL CONDUCTORS ARE 18 AWG CONDUCTORS.

REFERENCE DWG 1192-R03B-285787 FOR DETAILED CABLE ASSEMBLY DIAGRAM.

REV.	DATE	DESCRIPTION	BY	APPR.
05	05 NOV 07	REMOVED 240V FROM THIS DWG AND MADE NEW 324504 DWG FOR 240V SETUP.	AMG	
04	9 APR 07	ADDED GND WIRES TO P43, & J42	DMD	
03	11 MAR 07	ADDED TB41 FOR SIGNAL RE-DRIVE	DMD	
02	11 JAN 07	UPDATED 240V 0A PACKET INFORMATION	JDD	

THE CONCEPTS EXPRESSED AND DETAILS SHOWN ON THIS DRAWING ARE CONFIDENTIAL AND PROPRIETARY. DO NOT REPRODUCE BY ANY MEANS, INCLUDING ELECTRONICALLY WITHOUT THE EXPRESSED WRITTEN CONSENT OF DAKTRONICS, INC. COPYRIGHT 2002 DAKTRONICS, INC.			
DAKTRONICS, INC. BROOKINGS, SD 57006			
PROJ: OUTDOOR LED SCOREBOARDS			
TITLE: SCHEMATIC; GEN IV OUTDOOR LED, 16 COL DRIVER			
DES. BY:		DRAWN BY: DDINING	DATE: 25 SEP 06
REVISION	APPR. BY: MMILLER	1192-R03A-285779	
05	SCALE: NONE		

MASTER CONFIGURATION
OA-1192-4254

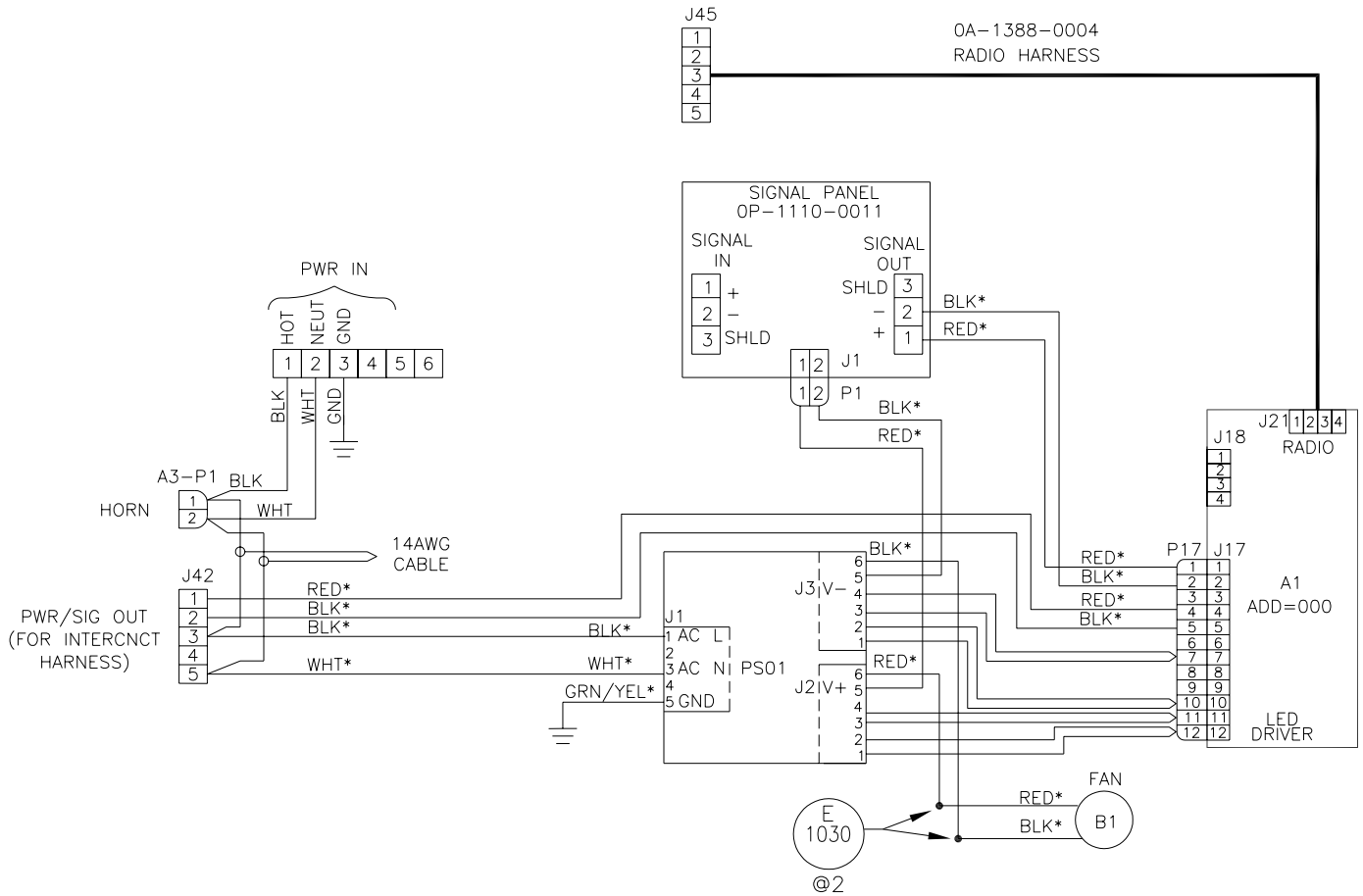

ALL CONDUCTORS ARE 14AWG EXCEPT * INDICATES 18AWG CONDUCTORS. ALL SIGNAL WIRES IS ALSO 18AWG.

REFERENCE DWG 1192-R03C-285872 FOR DETAILED CABLE ASSEMBLY DIAGRAM.

THE CONCEPTS EXPRESSED AND DETAILS SHOWN ON THIS DRAWING ARE CONFIDENTIAL AND PROPRIETARY. DO NOT REPRODUCE BY ANY MEANS, INCLUDING ELECTRONICALLY WITHOUT THE EXPRESSED WRITTEN CONSENT OF DAKTRONICS, INC. COPYRIGHT 2002 DAKTRONICS, INC.			
DAKTRONICS, INC. BROOKINGS, SD 57006			
PROJ: OUTDOOR LED SCOREBOARDS			
TITLE: SCHEMATIC; GEN IV OUTDOOR LED 8 COL. DRIVER ASSY			
DES. BY:	DRAWN BY: DDINING	DATE: 26 SEPT 06	
REVISION	APPR. BY: MMILLER	1192-R03A-285881	
01	SCALE: NONE		

01	13 AUG 07	ADDED RADIO HARNESS	DKD	
REV.	DATE	DESCRIPTION	BY	APPR.

LED DRIVER IV
 OP-1192-0383, 16 COL
 OP-1192-0384, 16 COL, AC

REFER TO DWGS
 A-115078 & A-115079
 FOR ADDRESS SETTINGS

REFER TO DWGS
 A-290261 & A-290689

S1 ADDRESS
 DIP SWITCH PACKAGE

J19 ADDRESS

PIN	FUNCTION
1	GND-N
2	ADD0-N
3	ADD1-N
4	GND-N
5	ADD2-N
6	ADD3-N
7	GND-N
8	ADD4-N
9	ADD5-N
10	GND-N
11	ADD6-N
12	ADD7-N

SW #	FUNCTION
1	ADD0
2	ADD1
3	ADD2
4	ADD3
5	ADD4
6	ADD5
7	ADD6
8	ADD7

J17 PWR/SIG

PIN	FUNCTION
1	SIG-P
2	SIG-N (232-IN)
3	SIG 2-P(232-GND)
4	CLOUT-P
5	CLOUT-N
6	16VAC-N
7	GND-N
8	EARTH-N
9	16VAC-P
10	GND-N
11	+VDD-P
12	+VBB-P

J22 RC-100 RADIO

PIN	FUNCTION
1	+UNREG-P
2	GND-N
3	GND-N
4	RX_INPUT-P

J23 PROGRAM

PIN	FUNCTION
1	DATA
2	/RESET
3	N/C
4	GND-N
5	CLK
6	GND-N
7	N/C
8	+5V-P
9	N/C
10	+5V-P

J21 2.4GHz RADIO

PIN	FUNCTION
1	+UNREG-P
2	GND-N
3	GND-N
4	RX_INPUT-P

J1-16 DIGIT JACKS

PIN	FUNCTION
1	SEGC-N
2	SEGB-N
3	SEGA-N
4	SEGF-N
5	SEGE-N
6	SEGD-N
7	+VBB-P
8	SEGH-N
9	SEGG-N

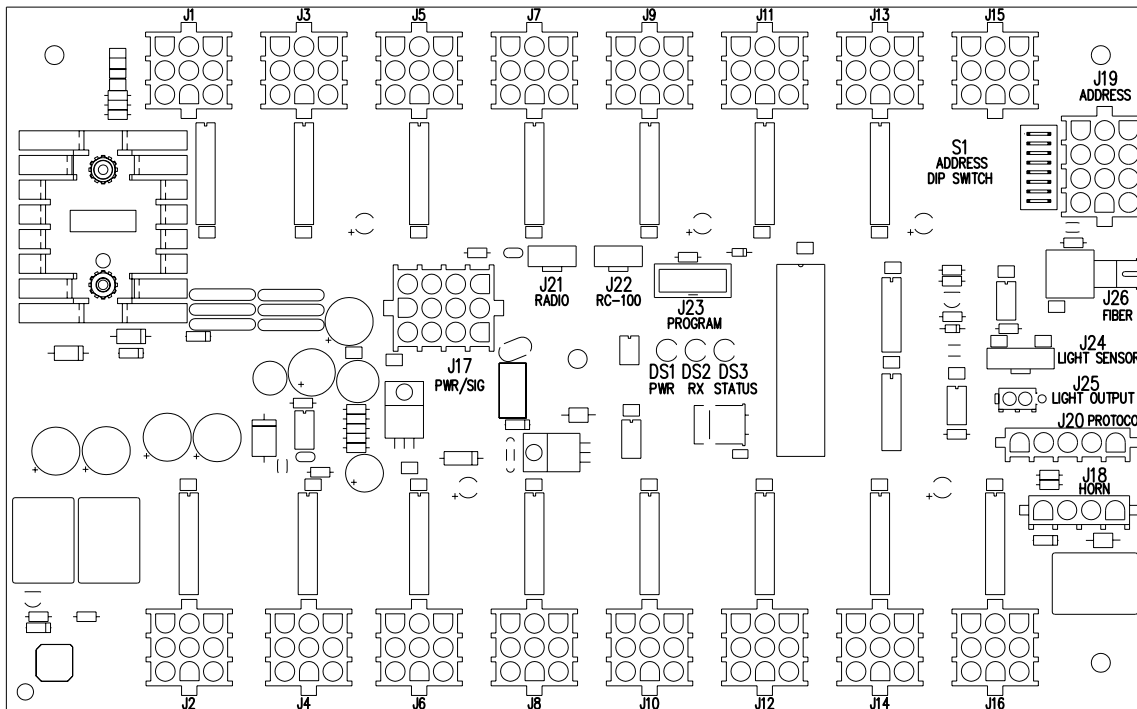

J26 FIBER RX

PIN	FUNCTION
1	N/C
2	+5V-P
3	GND-N
4	N/C
5	N/C
6	RX_INPUT-P
7	GND-N
8	N/C

J24 LIGHT SENSOR

PIN	FUNCTION
1	LIGHT_IN-P
2	LIGHT_IN-N
3	+5V-P
4	GND-N
5	GND-N
6	N/C

J25 LIGHT OUT- NEXT DRIVER

PIN	FUNCTION
1	LIGHT_OUT-P
2	LIGHT_OUT-N

REFER TO DWG A-115081
 FOR PROTOCOL SETTINGS

J20 PROTOCOL

PIN	FUNCTION
1	GND-N
2	PRO-N
3	PR1-N
4	PR2-N
5	PR3-N (TOD)

J18 HORN

PIN	FUNCTION
1	HORNOUT-N
2	AUXOUT-N
3	120SW-P
4	120SW-N

NOTES:

- WITH NO ADDRESS SELECTED, DRIVER WILL DEFAULT TO A/S 4000 PROTOCOL.
- GREEN LED DS1 INDICATES THAT THE DRIVER HAS POWER.
- RED LED DS2 WILL FLICKER WHEN THE DRIVER RECEIVES SIGNAL.
- AMBER LED DS3 WILL BLINK WHEN THE DRIVER IS RUNNING.
- IF DS3 IS ON OR OFF CONTINUOUSLY THE MICROCONTROLLER IS NOT WORKING.
- REFER TO DRAWING A-128429 FOR CURRENT LOOP REDRIVE SPECIFICATIONS.
- REFER TO DRAWING A-115081 FOR J20 PROTOCOL SETTINGS.
- REFER TO DRAWINGS A-115078,115079 FOR J19 ADDRESS SETTINGS.

THE CONCEPTS EXPRESSED AND DETAILS SHOWN ON THIS DRAWING ARE CONFIDENTIAL AND PROPRIETARY. DO NOT REPRODUCE BY ANY MEANS, INCLUDING ELECTRONICALLY WITHOUT THE EXPRESSED WRITTEN CONSENT OF DAKTRONICS, INC. COPYRIGHT 2006 DAKTRONICS, INC.

DAKTRONICS, INC. BROOKINGS, SD 57006

PROJ: SPECIFICATIONS; LED DRIVER IV, 16 COL
 DES. BY: DULSCHM DRAWN BY: DULSCHM DATE: 09 OCT 06

REVISION 02 APPR. BY: SCALE: 1 = 2

1192-R04A-288137

REV.	DATE	DESCRIPTION	BY	APPR.
02	30 NOV 06	ADDED ADDRESS SWITCH S1 TO DRAWING	DJU	
01	26 OCT 06	RESIZED TEXT SO THAT IT WAS EASIER TO READ, AND CLARIFIED FUNCTIONS OF EACH JACK.	AFL	

LED DRIVER IV
 OP-1192-0391, 8 COL
 OP-1192-0392, 8 COL, AC

REFER TO DWGS
 A-115078 & A-115079
 FOR ADDRESS SETTINGS

REFER TO DWGS
 A-290261 & A-290689
**S1 ADDRESS
 DIP SWITCH PACKAGE**

J1-8 DIGIT JACKS

PIN	FUNCTION
1	SEGC-N
2	SEGB-N
3	SEGA-N
4	SEGF-N
5	SEGE-N
6	SEGD-N
7	+VBB-P
8	SEGH-N
9	SEGG-N

J17 PWR/SIG

PIN	FUNCTION
1	SIG-P
2	SIG-N (232-IN)
3	SIG 2-P(232-GND)
4	CLOUT-P
5	CLOUT-N
6	16VAC-N
7	GND-N
8	EARTH-N
9	16VAC-P
10	GND-N
11	+VDD-P
12	+VBB-P

J22 RC-100 RADIO

PIN	FUNCTION
1	+UNREG-P
2	GND-N
3	GND-N
4	RX_INPUT-P

J21 2.4GHz RADIO

PIN	FUNCTION
1	+UNREG-P
2	GND-N
3	GND-N
4	RX_INPUT-P

J23 PROGRAM

PIN	FUNCTION
1	DATA
2	/RESET
3	N/C
4	GND-N
5	CLK
6	GND-N
7	N/C
8	+5V-P
9	N/C
10	+5V-P

J19 ADDRESS

PIN	FUNCTION
1	GND-N
2	ADD0-N
3	ADD1-N
4	GND-N
5	ADD2-N
6	ADD3-N
7	GND-N
8	ADD4-N
9	ADD5-N
10	GND-N
11	ADD6-N
12	ADD7-N

SW #	FUNCTION
1	ADD0
2	ADD1
3	ADD2
4	ADD3
5	ADD4
6	ADD5
7	ADD6
8	ADD7

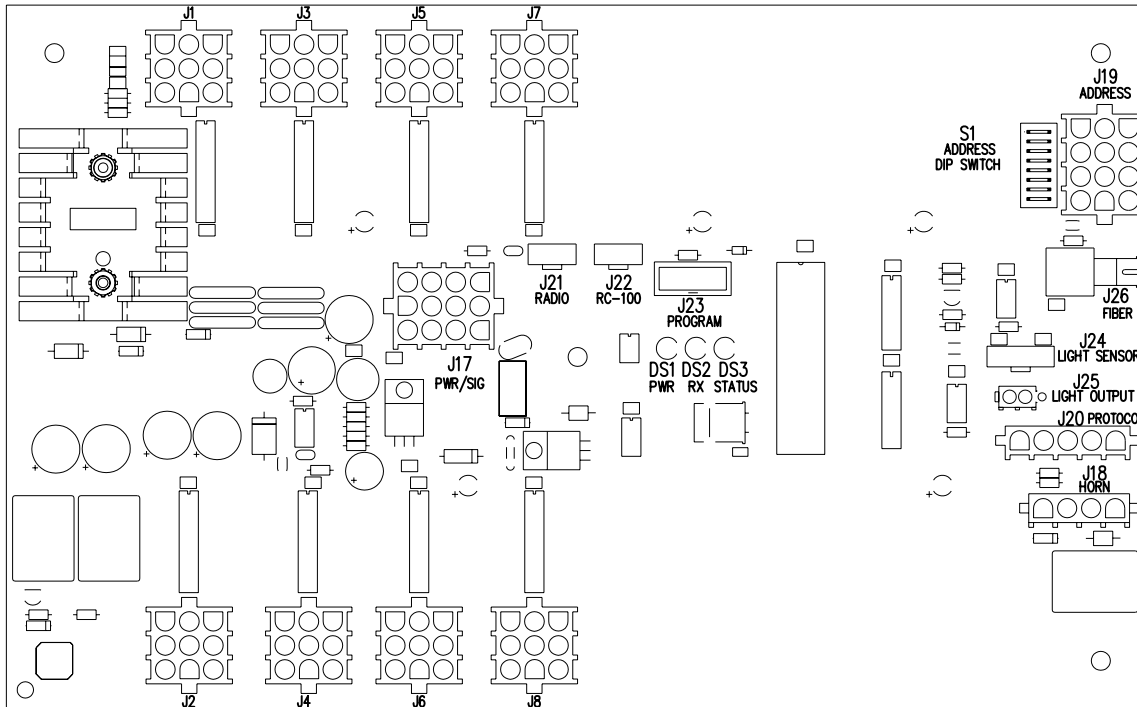

J26 FIBER RX

PIN	FUNCTION
1	N/C
2	+5V-P
3	GND-N
4	N/C
5	N/C
6	RX_INPUT-P
7	GND-N
8	N/C

J24 LIGHT SENSOR

PIN	FUNCTION
1	LIGHT_IN-P
2	LIGHT_IN-N
3	+5V-P
4	GND-N
5	GND-N
6	N/C

J25 LIGHT OUT- NEXT DRIVER

PIN	FUNCTION
1	LIGHT_OUT-P
2	LIGHT_OUT-N

REFER TO DWG A-115081
 FOR PROTOCOL SETTINGS

J20 PROTOCOL

PIN	FUNCTION
1	GND-N
2	PRO-N
3	PR1-N
4	PR2-N
5	PR3-N (TOD)

J18 HORN

PIN	FUNCTION
1	HORNOUT-N
2	AUXOUT-N
3	120SW-P
4	120SW-N

NOTES:

- WITH NO ADDRESS SELECTED, DRIVER WILL DEFAULT TO A/S 4000 PROTOCOL.
- GREEN LED DS1 INDICATES THAT THE DRIVER HAS POWER.
- RED LED DS2 WILL FLICKER WHEN THE DRIVER RECEIVES SIGNAL.
- AMBER LED DS3 WILL BLINK WHEN THE DRIVER IS RUNNING.
- IF DS3 IS ON OR OFF CONTINUOUSLY THE MICROCONTROLLER IS NOT WORKING.
- REFER TO DRAWING A-128429 FOR CURRENT LOOP REDRIVE SPECIFICATIONS.
- REFER TO DRAWING A-115081 FOR J20 PROTOCOL SETTINGS.
- REFER TO DRAWINGS A-115078,115079 FOR J19 ADDRESS SETTINGS.

THE CONCEPTS EXPRESSED AND DETAILS SHOWN ON THIS DRAWING ARE CONFIDENTIAL AND PROPRIETARY. DO NOT REPRODUCE BY ANY MEANS, INCLUDING ELECTRONICALLY WITHOUT THE EXPRESSED WRITTEN CONSENT OF DAKTRONICS, INC. COPYRIGHT 2006 DAKTRONICS, INC.

DAKTRONICS, INC. BROOKINGS, SD 57006

PROJ: _____
 TITLE: SPECIFICATIONS; LED DRIVER IV, 8 COL
 DES. BY: _____ DRAWN BY: DULSCHM DATE: 09 OCT 06

REVISION	APPR. BY:	SCALE:
02	1 = 2	

1192-R04A-288138

REV.	DATE	DESCRIPTION	BY	APPR.
02	30 NOV 06	ADDED ADDRESS SWITCH S1 TO DRAWING	DJU	
01	26 OCT 06	RESIZED TEXT SO IT WAS EASIER TO READ, AND CLARIFIED FUNCTIONS OF EACH JACK.	AFL	

DIP SWITCH ADDRESS SETTING	
DECIMAL ADDRESS	SW 8 SW 7 SW 6 SW 5 SW 4 SW 3 SW 2 SW 1
01	0 0 0 0 0 0 0 1
02	0 0 0 0 0 0 1 0
03	0 0 0 0 0 0 1 1
04	0 0 0 0 0 1 0 0
05	0 0 0 0 0 1 0 1
06	0 0 0 0 0 1 1 0
07	0 0 0 0 0 1 1 1
08	0 0 0 0 1 0 0 0
09	0 0 0 0 1 0 0 1
10	0 0 0 0 1 0 1 0
11	0 0 0 0 1 0 1 1
12	0 0 0 0 1 1 0 0
13	0 0 0 0 1 1 0 1
14	0 0 0 0 1 1 1 0
15	0 0 0 0 1 1 1 1
16	0 0 0 1 0 0 0 0

DIP SWITCH ADDRESS SETTING	
DECIMAL ADDRESS	SW 8 SW 7 SW 6 SW 5 SW 4 SW 3 SW 2 SW 1
33	0 0 0 1 0 0 0 1
34	0 0 0 1 0 0 0 0
35	0 0 0 1 0 0 1 1
36	0 0 0 1 0 0 0 0
37	0 0 0 1 0 0 1 0
38	0 0 0 1 0 0 1 1
39	0 0 0 1 0 0 1 1
40	0 0 0 1 0 1 0 0
41	0 0 0 1 0 1 0 1
42	0 0 0 1 0 1 0 0
43	0 0 0 1 0 1 0 1
44	0 0 0 1 0 1 1 0
45	0 0 0 1 0 1 1 0
46	0 0 0 1 0 1 1 0
47	0 0 0 1 0 1 1 1
48	0 0 0 1 1 0 0 0

DIP SWITCH ADDRESS SETTING	
DECIMAL ADDRESS	SW 8 SW 7 SW 6 SW 5 SW 4 SW 3 SW 2 SW 1
65	0 1 0 0 0 0 1 1
66	0 1 0 0 0 0 1 0
67	0 1 0 0 0 0 1 1
68	0 1 0 0 0 1 0 0
69	0 1 0 0 0 1 0 1
70	0 1 0 0 0 1 1 0
71	0 1 0 0 0 1 1 1
72	0 1 0 0 1 0 0 0
73	0 1 0 0 1 0 0 1
74	0 1 0 0 1 0 1 0
75	0 1 0 0 1 0 1 1
76	0 1 0 0 1 1 0 0
77	0 1 0 0 1 1 0 1
78	0 1 0 0 1 1 1 0
79	0 1 0 0 1 1 1 1
80	0 1 0 1 0 0 0 0

DIP SWITCH ADDRESS SETTING	
DECIMAL ADDRESS	SW 8 SW 7 SW 6 SW 5 SW 4 SW 3 SW 2 SW 1
97	0 1 1 0 0 0 1 1
98	0 1 1 0 0 0 1 0
99	0 1 1 0 0 0 1 1
100	0 1 1 0 0 1 0 0
101	0 1 1 0 0 1 0 1
102	0 1 1 0 0 1 1 0
103	0 1 1 0 0 1 1 1
104	0 1 1 0 1 0 0 0
105	0 1 1 0 1 0 0 1
106	0 1 1 0 1 0 1 0
107	0 1 1 0 1 0 1 1
108	0 1 1 0 1 1 0 0
109	0 1 1 0 1 1 0 1
110	0 1 1 0 1 1 1 0
111	0 1 1 0 1 1 1 1
112	0 1 1 1 0 0 0 0

DIP SWITCH ADDRESS SETTING	
DECIMAL ADDRESS	SW 8 SW 7 SW 6 SW 5 SW 4 SW 3 SW 2 SW 1
17	0 0 0 1 0 0 0 1
18	0 0 0 1 0 0 1 0
19	0 0 0 1 0 0 1 1
20	0 0 0 1 0 1 0 0
21	0 0 0 1 0 1 0 1
22	0 0 0 1 0 1 1 0
23	0 0 0 1 0 1 1 1
24	0 0 0 1 1 0 0 0
25	0 0 0 1 1 0 0 1
26	0 0 0 1 1 0 1 0
27	0 0 0 1 1 0 1 1
28	0 0 0 1 1 1 0 0
29	0 0 0 1 1 1 0 1
30	0 0 0 1 1 1 1 0
31	0 0 0 1 1 1 1 1
32	0 0 1 0 0 0 0 0

DIP SWITCH ADDRESS SETTING	
DECIMAL ADDRESS	SW 8 SW 7 SW 6 SW 5 SW 4 SW 3 SW 2 SW 1
49	0 0 1 1 0 0 0 1
50	0 0 1 1 0 0 1 0
51	0 0 1 1 0 0 1 1
52	0 0 1 1 0 1 0 0
53	0 0 1 1 0 1 0 1
54	0 0 1 1 0 1 1 0
55	0 0 1 1 0 1 1 1
56	0 0 1 1 1 0 0 0
57	0 0 1 1 1 0 0 1
58	0 0 1 1 1 0 1 0
59	0 0 1 1 1 0 1 1
60	0 0 1 1 1 1 0 0
61	0 0 1 1 1 1 0 1
62	0 0 1 1 1 1 1 0
63	0 0 1 1 1 1 1 1
64	0 1 0 0 0 0 0 0

DIP SWITCH ADDRESS SETTING	
DECIMAL ADDRESS	SW 8 SW 7 SW 6 SW 5 SW 4 SW 3 SW 2 SW 1
81	0 1 0 1 0 0 0 1
82	0 1 0 1 0 0 1 0
83	0 1 0 1 0 0 1 1
84	0 1 0 1 0 1 0 0
85	0 1 0 1 0 1 0 1
86	0 1 0 1 0 1 1 0
87	0 1 0 1 0 1 1 1
88	0 1 0 1 1 0 0 0
89	0 1 0 1 1 0 0 1
90	0 1 0 1 1 0 1 0
91	0 1 0 1 1 0 1 1
92	0 1 0 1 1 1 0 0
93	0 1 0 1 1 1 0 1
94	0 1 0 1 1 1 1 0
95	0 1 0 1 1 1 1 1
96	0 1 1 0 0 0 0 0

DIP SWITCH ADDRESS SETTING	
DECIMAL ADDRESS	SW 8 SW 7 SW 6 SW 5 SW 4 SW 3 SW 2 SW 1
113	0 1 1 1 0 0 0 1
114	0 1 1 1 0 0 1 0
115	0 1 1 1 0 0 1 1
116	0 1 1 1 0 1 0 0
117	0 1 1 1 0 1 0 1
118	0 1 1 1 0 1 1 0
119	0 1 1 1 0 1 1 1
120	0 1 1 1 1 0 0 0
121	0 1 1 1 1 0 0 1
122	0 1 1 1 1 0 1 0
123	0 1 1 1 1 0 1 1
124	0 1 1 1 1 1 0 0
125	0 1 1 1 1 1 0 1
126	0 1 1 1 1 1 1 0
127	0 1 1 1 1 1 1 1
128	1 0 0 0 0 0 0 0

S1-ADDRESS DIP SWITCH
SCALE 2=1

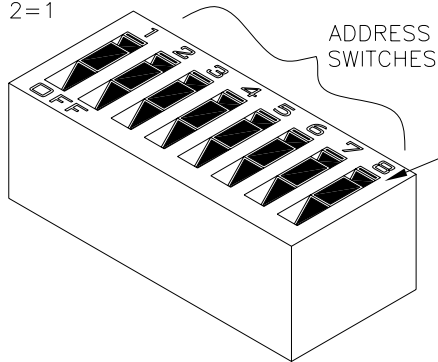

NOTES:

0 = OFF, 1 = ON.

TO TURN SWITCH ON, PRESS DOWN ON THE TOP SIDE OF THE SWITCH ROCKING IT TO THE OTHER POSITION.

THE CONCEPTS EXPRESSED AND DETAILS SHOWN ON THIS DRAWING ARE CONFIDENTIAL AND PROPRIETARY. DO NOT REPRODUCE BY ANY MEANS, INCLUDING ELECTRONICALLY WITHOUT THE EXPRESSED WRITTEN CONSENT OF DAKTRONICS, INC. COPYRIGHT 2005 DAKTRONICS, INC.			
DAKTRONICS, INC. BROOKINGS, SD 57006			
PROJ: OUTDOOR LED SCOREBOARDS			
TITLE: ADDRESS TABLE 1; GEN IV DRIVER ADDRESS DIP SWITCH			
DES. BY: MMILLER		DRAWN BY: MMILLER	
DATE: 16 NOV 06			
REVISION	APPR. BY:	1192-R10A-290261	
00	SCALE: 1 = 1		

REV.	DATE	DESCRIPTION	BY	APPR.

BA-2023-11/-21, G4

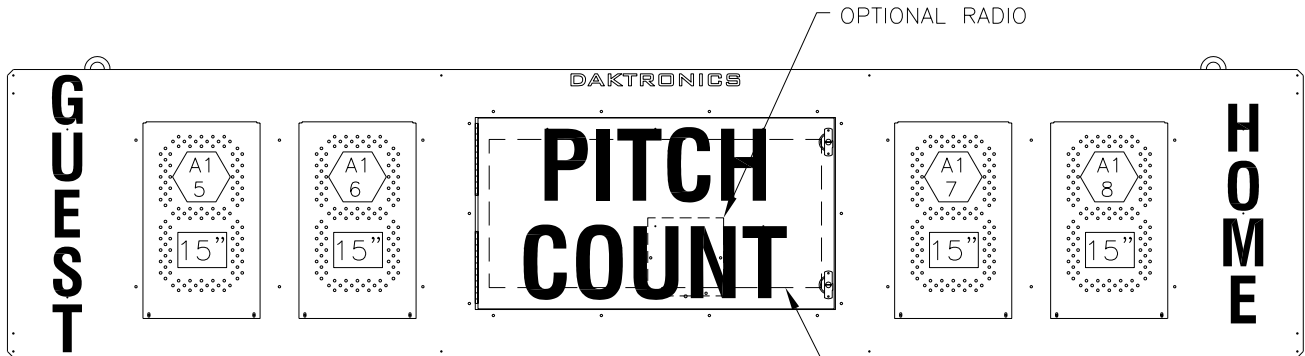

SEE DETAIL A
(MASTER DRIVER &
KNOCKOUT FOR 1/2" CONDUIT)

NOTES:

-  = LED DRIVER NUMBER & LED DRIVER CONNECTOR WIRED TO THAT DIGIT.
-  = DIGIT SIZE

ENCLOSED 18 COLUMN WIDE
MASTER LED DRIVER AND
POWER/SIGNAL ENCLOSURE @1.
(THE COVER HAS BEEN REMOVED
TO SHOW THE ENCLOSURE
COMPONENT DETAIL.)

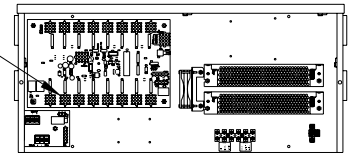

DETAIL: A

THE CONCEPTS EXPRESSED AND DETAILS SHOWN ON THIS DRAWING ARE CONFIDENTIAL AND PROPRIETARY. DO NOT REPRODUCE BY ANY MEANS, INCLUDING ELECTRONICALLY WITHOUT THE EXPRESSED WRITTEN CONSENT OF DAKTRONICS, INC. COPYRIGHT 2008 DAKTRONICS, INC.			
DAKTRONICS, INC. BROOKINGS, SD 57006			
PROJ: OUTDOOR LED SCOREBOARDS			
TITLE: COMPONENT LOCATION; BA-2023			
DES. BY: KDRAGT		DRAWN BY: KDRAGT	
		DATE: 22 JAN 08	
REVISION	APPR. BY:	1192-E08A-331219	
00	SCALE: 1=16		

REV.	DATE	DESCRIPTION	BY	APPR.

MASTER CONFIGURATION

0A-1192-4265 - 240VAC 0A-1192-4250 - 240VAC WIDE

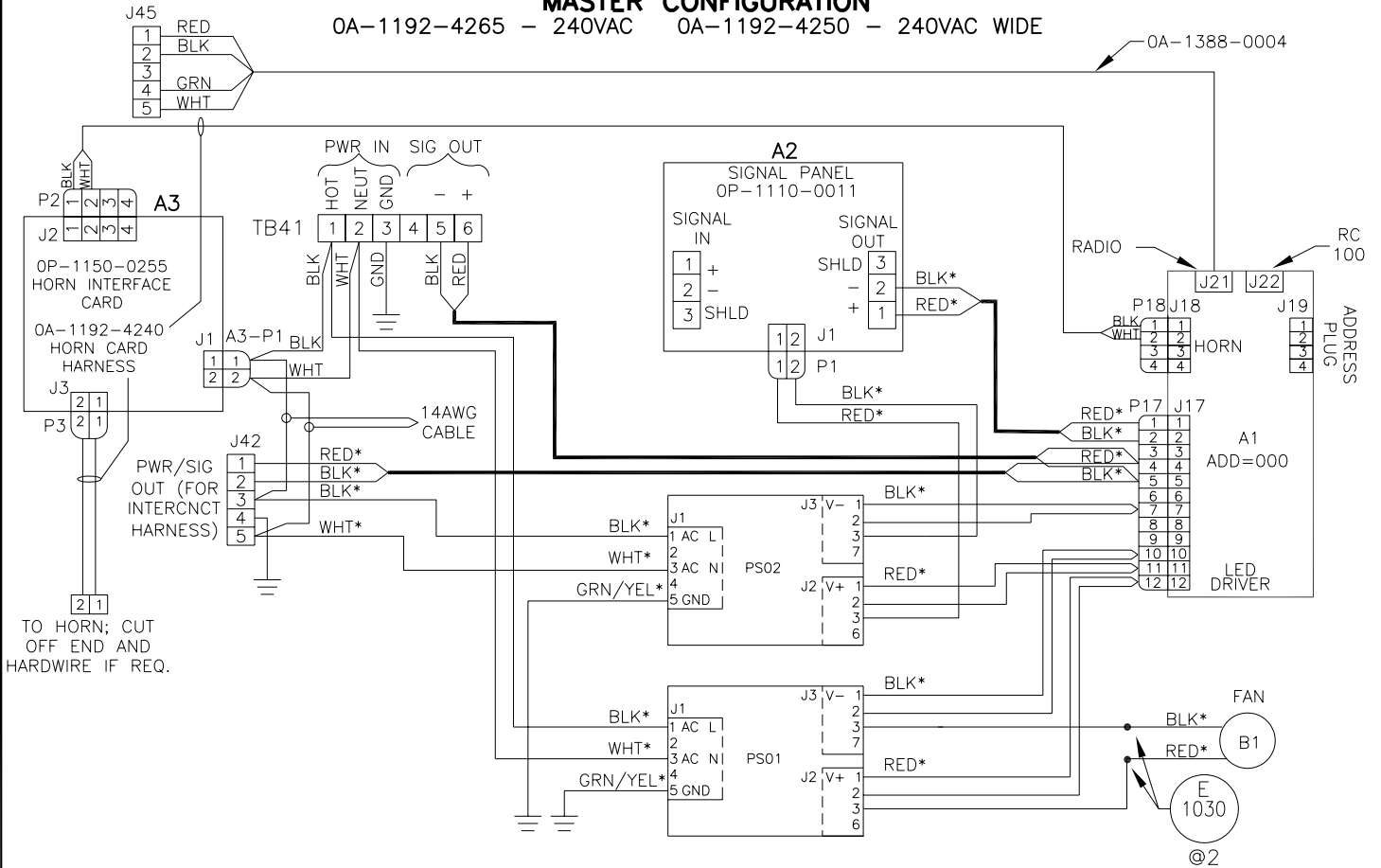

ALL CONDUCTORS ARE 14 AWG EXCEPT * INDICATES 18AWG CONDUCTORS.
ALL SIGNAL CONDUCTORS ARE ALSO 18 AWG CONDUCTORS.

REFERENCE DWG 1192-R03C-285776 FOR DETAILED CABLE ASSEMBLY DIAGRAM.

SLAVE CONFIGURATION

0A-1192-4266 - 240VAC 0A-1192-4251 - 240VAC WIDE

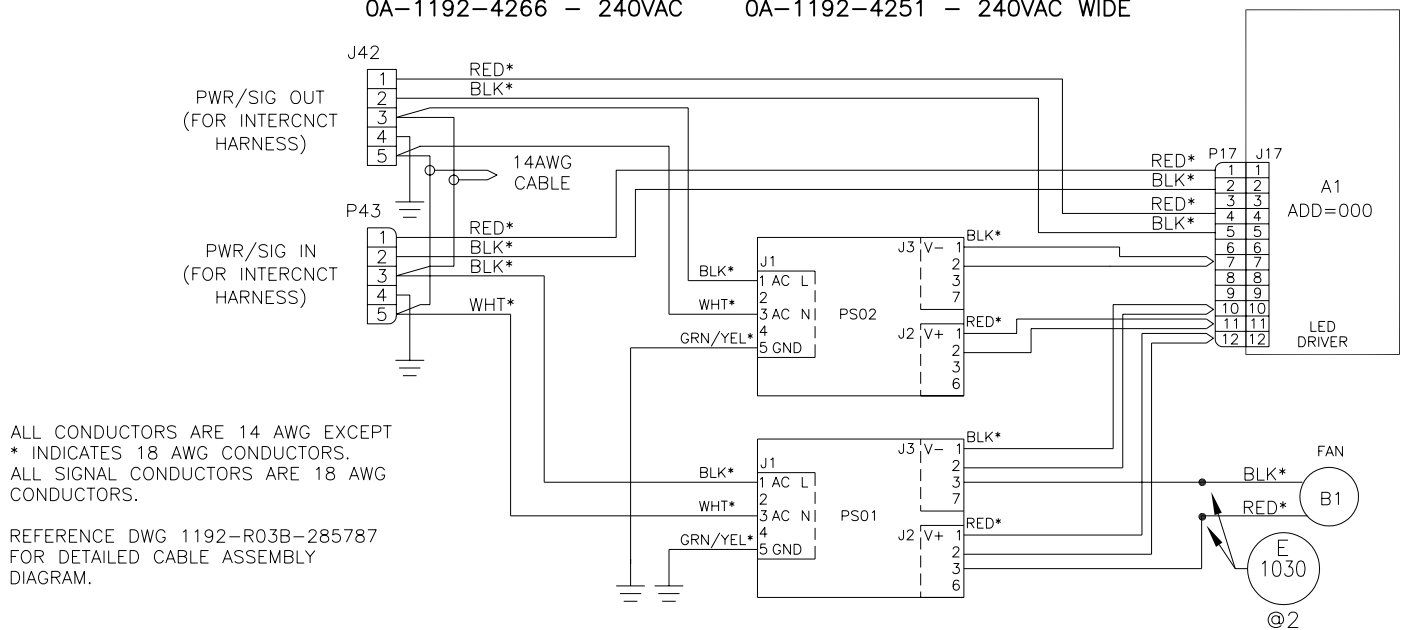

ALL CONDUCTORS ARE 14 AWG EXCEPT * INDICATES 18 AWG CONDUCTORS.
ALL SIGNAL CONDUCTORS ARE 18 AWG CONDUCTORS.

REFERENCE DWG 1192-R03B-285787 FOR DETAILED CABLE ASSEMBLY DIAGRAM.

THE CONCEPTS EXPRESSED AND DETAILS SHOWN ON THIS DRAWING ARE CONFIDENTIAL AND PROPRIETARY. DO NOT REPRODUCE BY ANY MEANS, INCLUDING ELECTRONICALLY WITHOUT THE EXPRESSED WRITTEN CONSENT OF DAKTRONICS, INC. COPYRIGHT 2002 DAKTRONICS, INC.

DAKTRONICS, INC. BROOKINGS, SD 57006

PROJ: OUTDOOR LED SCOREBOARDS

TITLE: SCHEMATIC: 240V GEN IV OUTDOOR LED- 16 COL DRIVER

DES. BY:

DRAWN BY: AGEWERT

DATE: 05 NOV 07

01	04 JUN 08	UPDATED LABELS	NLH	
REV.	DATE	DESCRIPTION	BY	APPR.

REVISION	APPR. BY: MMILLER
01	SCALE: NONE

1192-R03A-324504

REV.	DATE	DESCRIPTION	BY	APPR.

BA-2022-11/-21, G4

SEE DETAIL A
(MASTER DRIVER &
KNOCKOUT FOR 1/2"
CONDUIT)

OPTIONAL RADIO

SEE DETAIL B
(SLAVE DRIVER)

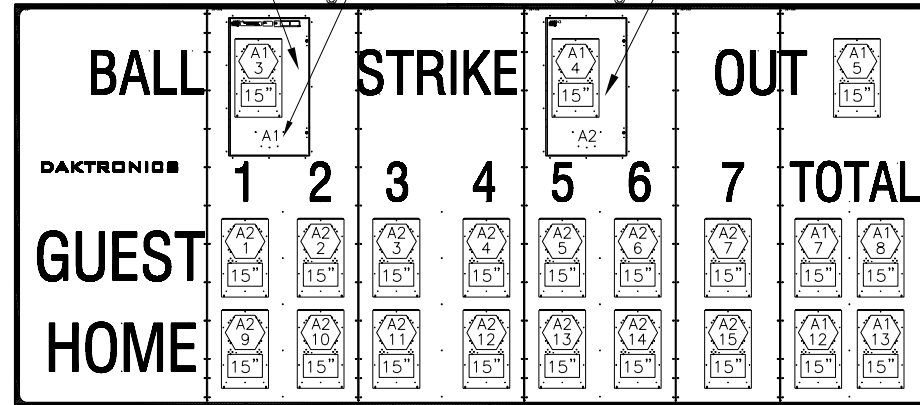

FRONT VIEW

ENCLOSED 16 COLUMN MASTER LED DRIVER AND POWER/SIGNAL ENCLOSURE @1. (THE COVER HAS BEEN REMOVED TO SHOW THE ENCLOSURE COMPONENT DETAIL.)

ENCLOSED 16 COLUMN SLAVE LED DRIVER AND POWER/SIGNAL ENCLOSURE @1. (THE COVER HAS BEEN REMOVED TO SHOW THE ENCLOSURE COMPONENT DETAIL.)

NOTES:

 = LED DRIVER NUMBER & LED DRIVER CONNECTOR WIRED TO THAT DIGIT.

 = DIGIT SIZE

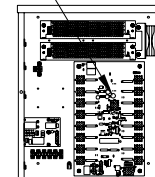

DETAIL: A
x2 SCALE

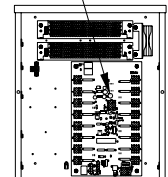

DETAIL: B
x2 SCALE

THE CONCEPTS EXPRESSED AND DETAILS SHOWN ON THIS DRAWING ARE CONFIDENTIAL AND PROPRIETARY. DO NOT REPRODUCE BY ANY MEANS, INCLUDING ELECTRONICALLY WITHOUT THE EXPRESSED WRITTEN CONSENT OF DAKTRONICS, INC. COPYRIGHT 2008 DAKTRONICS, INC.

PROJ: OUTDOOR LED SCOREBOARDS
DAKTRONICS, INC. BROOKINGS, SD 57006

TITLE: COMPONENT LOCATION: BA-2022-11/-21, G4
DES. BY: BCURTIS DRAWN BY: JDERAIL DATE: 03 JAN 08

REVISION 00 APPR. BY: 1407-R08A-329456

CT-2001-11/-21

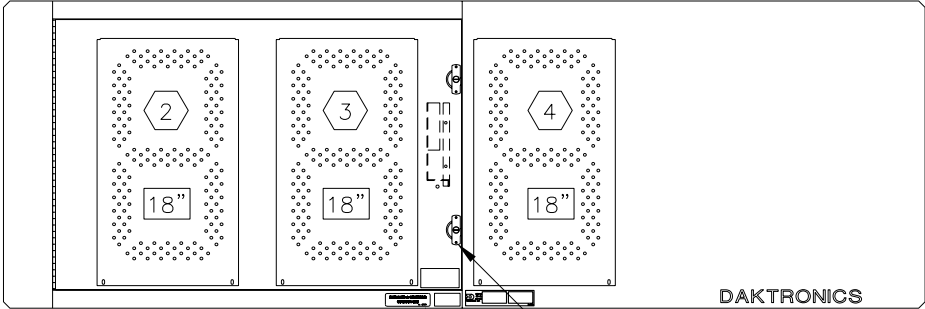

FRONT VIEW

USE FLAT HEAD SCREWDRIVER TO OPEN LATCHES AND ACCESS LED DRIVERS & PWR/SIG ENCLOSURE

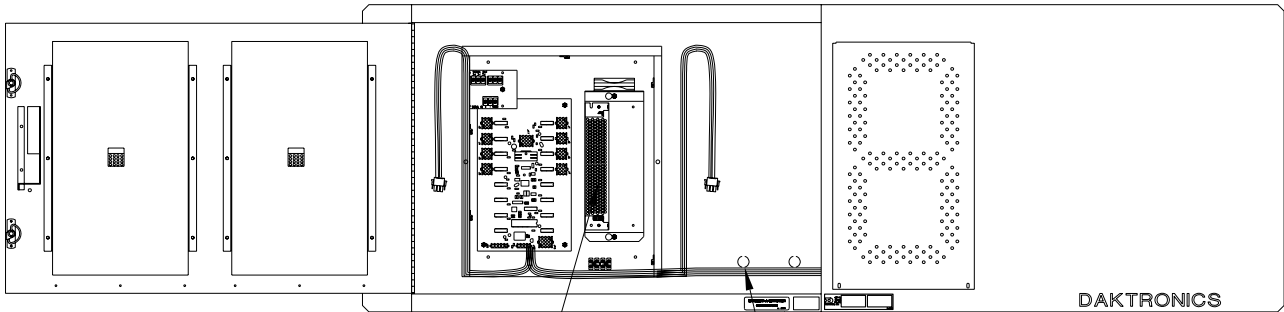

ENCLOSED 8 COLUMN LED DRIVER AND POWER & SIGNAL ENCLOSURE. (THE COVER HAS BEEN REMOVED TO SHOW THE DRIVER ENCLOSURE DETAIL).

KNOCKOUTS FOR 1/2" CONDUIT

FRONT VIEW
ACCESS DOOR OPEN

- ① = LED DRIVER CONNECTOR WIRED TO THAT DIGIT.
- 18" = DIGIT SIZE

THE CONCEPTS EXPRESSED AND DETAILS SHOWN ON THIS DRAWING ARE CONFIDENTIAL AND PROPRIETARY. DO NOT REPRODUCE BY ANY MEANS, INCLUDING ELECTRONICALLY WITHOUT THE EXPRESSED WRITTEN CONSENT OF DAKTRONICS, INC. COPYRIGHT 2008 DAKTRONICS, INC.			
DAKTRONICS, INC. BROOKINGS, SD 57006			
PROJ: OUTDOOR LED SCOREBOARDS			
TITLE: COMPONENT LOCATION; CT-2001-11/-21, G4			
DES. BY: TWEBER		DRAWN BY: BLERICKS	
		DATE: 22 JUL 08	
REVISION	APPR. BY:	1192-E08A-578903	
00	SCALE: 1=15		

REV.	DATE	DESCRIPTION	BY	APPR.

BA-2024-11/-21

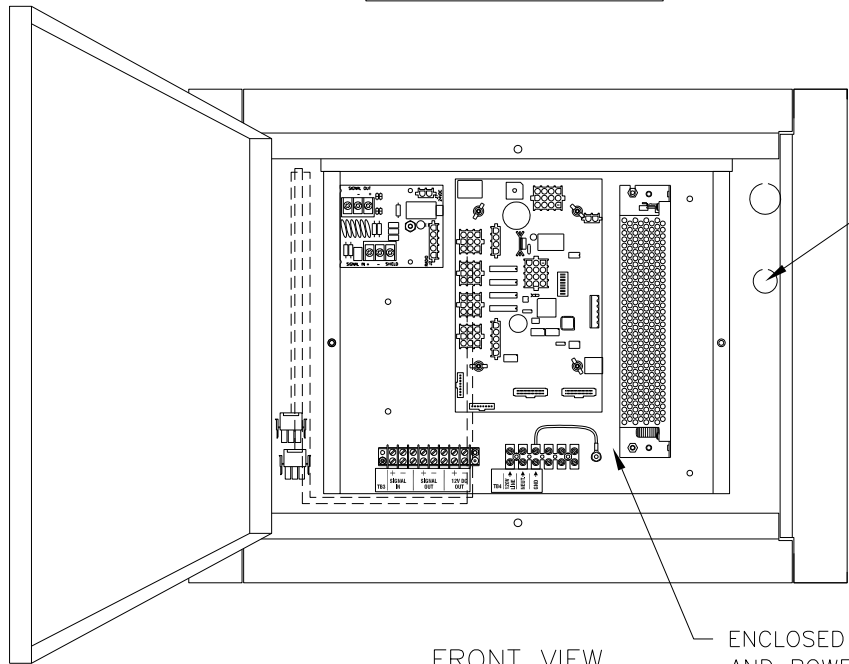

KNOCKOUTS FOR CONDUIT
(KNOCKOUTS CAN ALSO
BE FOUND ON BOTH SIDES
OF THIS DISPLAY)

FRONT VIEW
DOOR SHOWN OPEN

ENCLOSED 4 COLUMN LED DRIVER
AND POWER/SIGNAL ENCLOSURE.
(THE COVER HAS BEEN REMOVED
TO SHOW THE COMPONENT DETAIL).

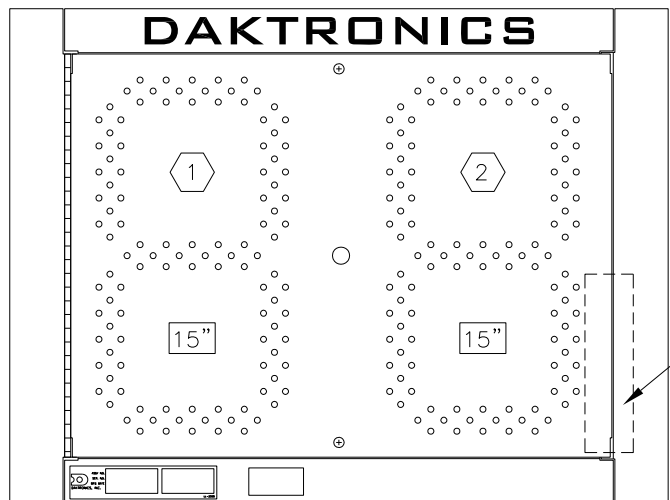

RADIO LOCATION
ANTENNA PROTRUDES
OUT END OF CABINET
(NOT FACE OF DISPLAY)

FRONT VIEW
DOOR SHOWN CLOSED

1 = DRIVER CONNECTOR
WIRED TO DIGIT

18" = DIGIT SIZE

THE CONCEPTS EXPRESSED AND DETAILS SHOWN ON THIS DRAWING ARE CONFIDENTIAL AND PROPRIETARY. DO NOT REPRODUCE BY ANY MEANS, INCLUDING ELECTRONICALLY WITHOUT THE EXPRESSED WRITTEN CONSENT OF DAKTRONICS, INC. COPYRIGHT 2009 DAKTRONICS, INC.			
DAKTRONICS, INC. BROOKINGS, SD 57006			
PROJ: OUTDOOR LED SCOREBOARDS			
TITLE: COMPONENT LOCATION; BA-2024-11/-21, G4			
DES. BY: KDRAGT		DRAWN BY: KDRAGT	DATE: 07 APR 09
REVISION	APPR. BY:	1192-R08A-825868	
00	SCALE: 1=7		

REV.	DATE	DESCRIPTION	BY	APPR.

PLASTIC HOUSING WITH WEATHERSTRIPPING FOR WATERPROOFING

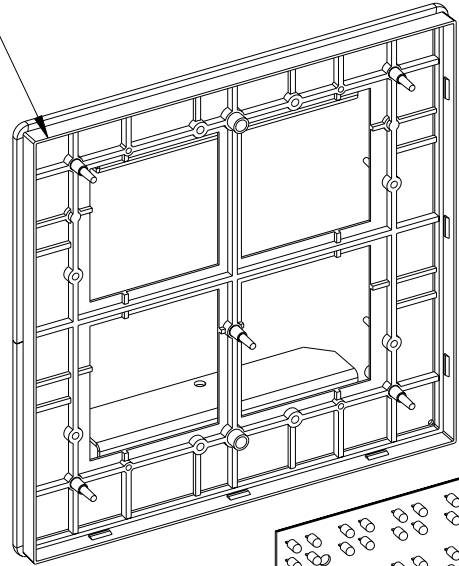

SINGLE LED AND DRIVER PANEL

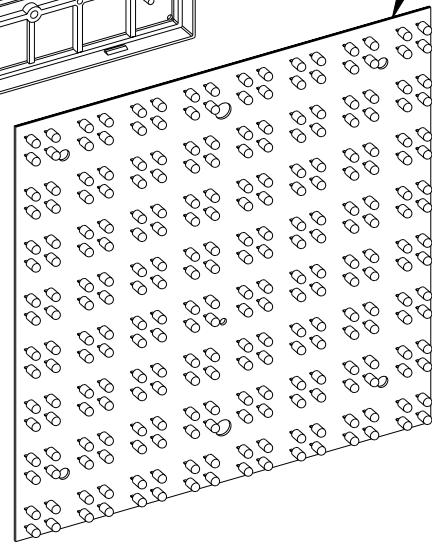

LOUVER

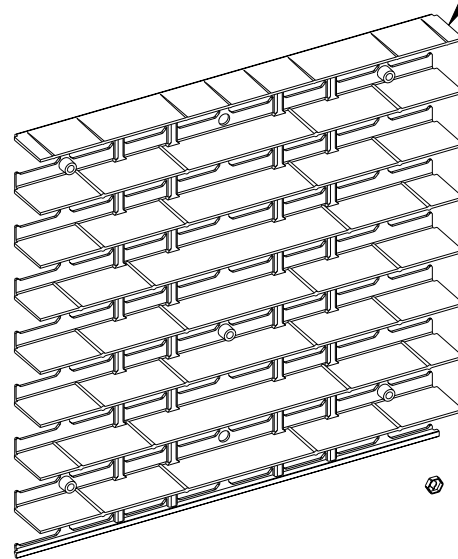

LATCH ACCESS PLUG @2 FOR FRONT AND REAR MODULE ACCESS AND WATERPROOFING



TWIST ON FASTENERS @5 FOR ATTACHMENT OF LOUVER



DAKTRONICS, INC. BROOKINGS, SD 57006

PROJ: 34MM OUTDOOR GALAXY

TITLE: EXPLODED FRONT VIEW; SINGLE PANEL MODULE

DES. BY: NANDAL DRAWN BY: DNUGTEREN DATE: 10JAN00

REVISION SHEET 1 OF DWG 126111

SCALE: 1=2

1208-E10B-126111

REV.	DATE	DESCRIPTION	BY	APPR.

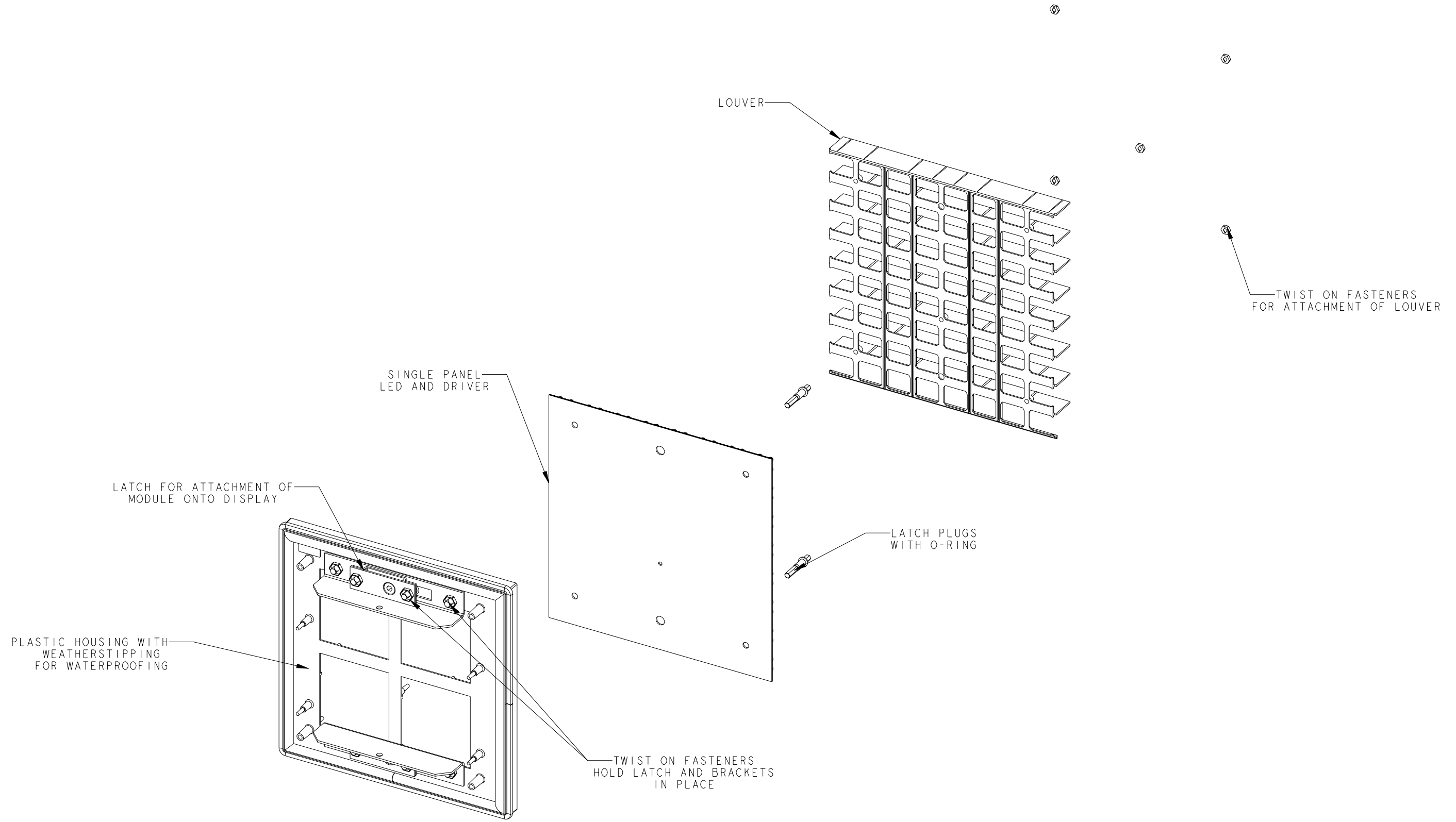

DAKTRONICS, INC. BROOKINGS, SD 57006	
PROJ:	34MM OUTDOOR GALAXY
TITLE:	EXPLODED REAR VIEW; SINGLE PANEL MODULE
DES. BY:	NANDAL
DRAWN BY:	DNUGTEREN
DATE:	10JAN00
REVISION	SHEET 1 OF DWG 126112
SCALE:	1=2
1208 - E10B - 126112	

REV.	DATE	DESCRIPTION	BY	APPR.

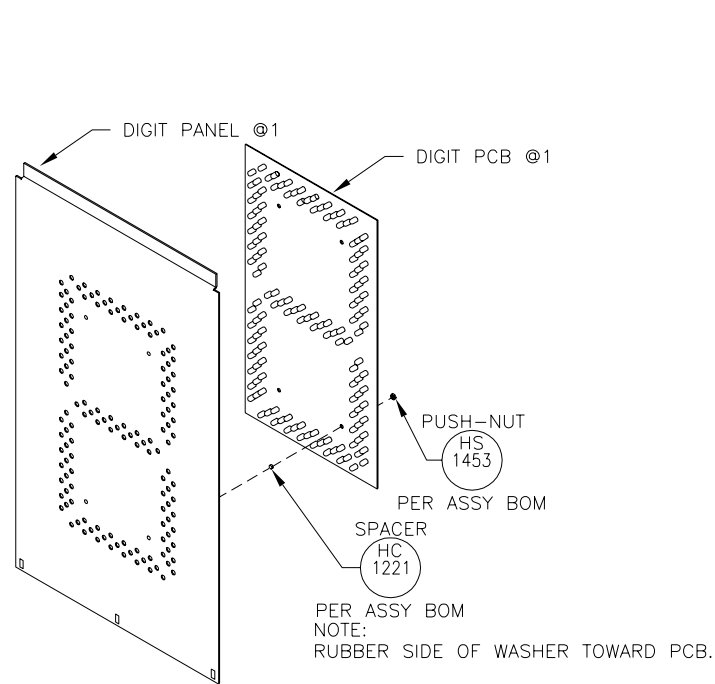

DETAIL: A

REFER TO THIS DETAIL FOR THE FOLLOWING RED, GRN, AND AMBER LED DIGIT ASSEMBLY SIZES:
 -5", 7", 10", 15", 18", SMALL FB IND, AND LARGE FB IND (NOTE THAT THE FB INDICATORS DO NOT LOOK LIKE THE DIGIT IN THE ABOVE DETAIL. THESE INDICATORS ARE ASSEMBLED WITH THE SAME METHOD AS THE DIGIT SHOWN IN THE ABOVE DETAIL.)

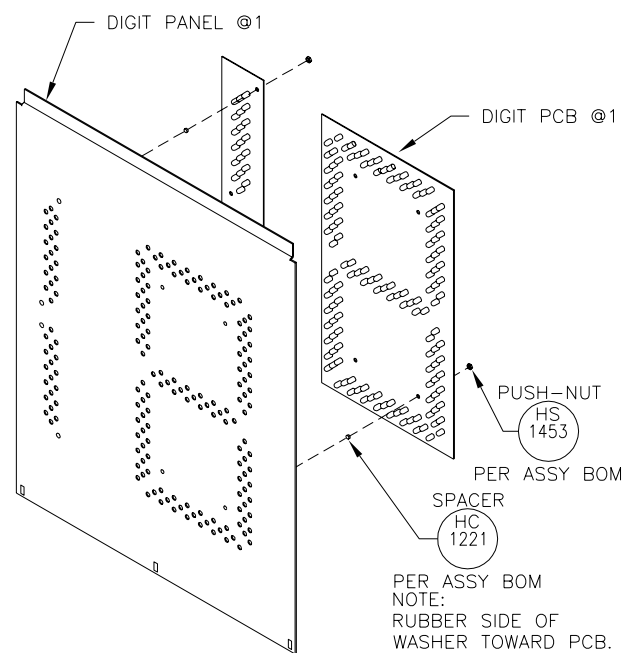

DETAIL: B

REFER TO THIS DETAIL FOR THE FOLLOWING RED, GRN, AND AMBER LED DIGIT ASSEMBLY SIZES:
 -15"+1, AND 18"+1

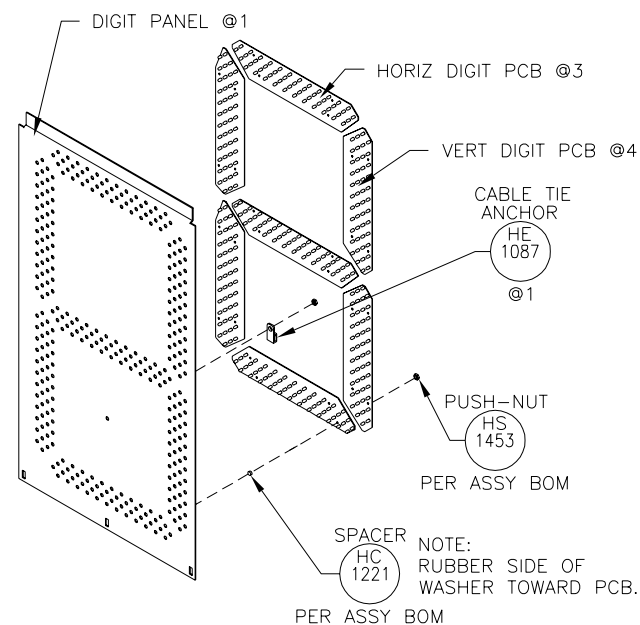

DETAIL: C

REFER TO THIS DETAIL FOR THE FOLLOWING RED, GRN, AND AMBER LED DIGIT ASSEMBLY SIZES:
 -24", 24" WIDE, 30", 30" WIDE, 36", 42", 48", 60"

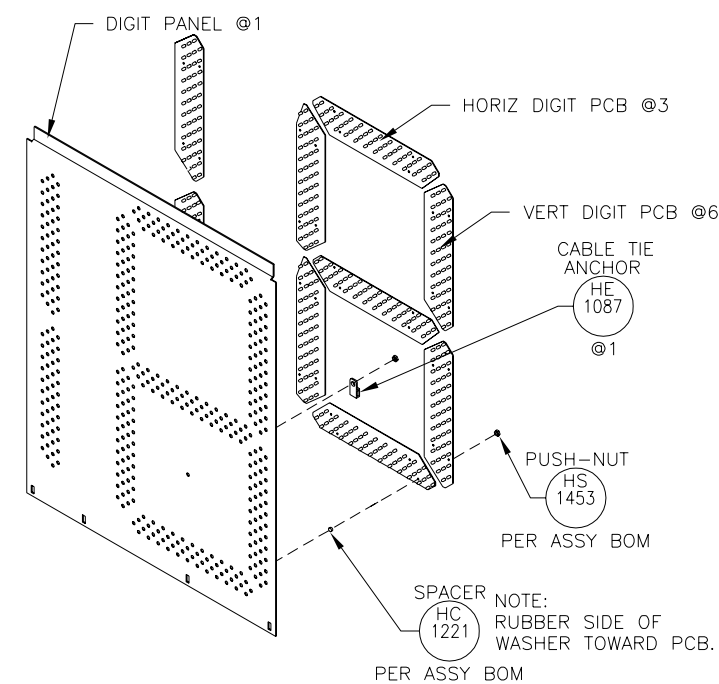

DETAIL: D

REFER TO THIS DETAIL FOR THE FOLLOWING RED, GRN, AND AMBER LED DIGIT ASSEMBLY SIZES:
 -24"+1, 30"+1, 36"+1

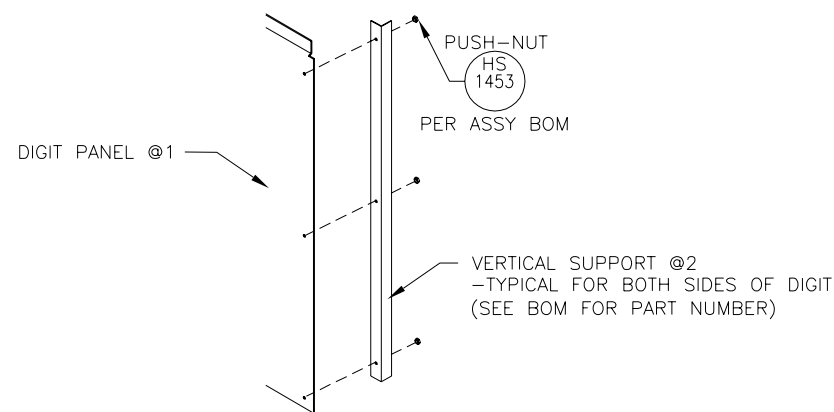

DETAIL: E

REFER TO THIS DETAIL FOR THE FOLLOWING RED, GRN, AND AMBER LED DIGIT ASSEMBLY SIZES:
 48", AND 48"+1

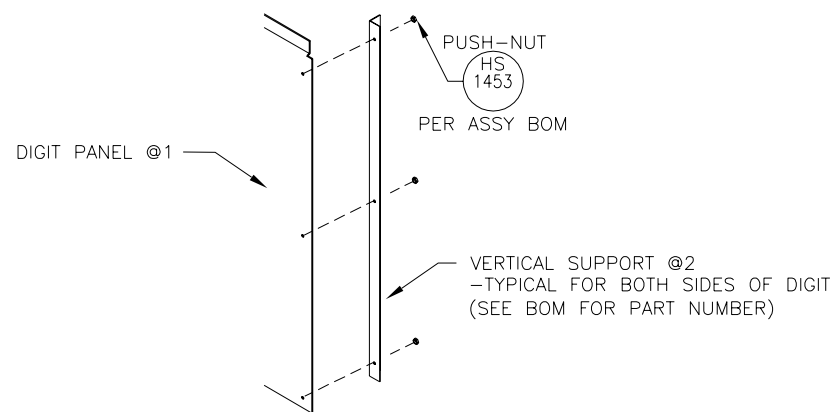

DETAIL: F

REFER TO THIS DETAIL FOR THE FOLLOWING RED, GRN, AND AMBER LED DIGIT ASSEMBLY SIZES:
 -30", 30"+1, AND 30" WIDE.

NOTE: IN SOME APPLICATIONS, THE LED DIGIT PCB MAY BE MOUNTED DIRECTLY TO THE FACE PANEL OF THE SCOREBOARD INSTEAD OF THE LED DIGIT PANEL. THE SAME HARDWARE WILL BE USED TO INSTALL THE LED DIGIT PCB. THE LED SCOREBOARD FACE PANEL CAN BE SUBSTITUTED FOR THE LED DIGIT PANEL IN ALL DETAILS.

REV	DATE	DESCRIPTION	BY	APPR.

THE CONCEPTS EXPRESSED AND DETAILS SHOWN ON THIS DRAWING ARE CONFIDENTIAL AND PROPRIETARY. DO NOT REPRODUCE BY ANY MEANS, INCLUDING ELECTRONICALLY WITHOUT THE EXPRESSED WRITTEN CONSENT OF DAKTRONICS, INC. COPYRIGHT 2002 DAKTRONICS, INC.

DAKTRONICS, INC. BROOKINGS, SD 57006

PROJ: OUTDOOR LED SCOREBOARDS

TITLE: DIGIT ASSEMBLIES: GEN III LED DIGITS

DES. BY: MCOPLAN DRAWN BY: MCOPLAN DATE: 30OCT02

06	16 APR 08	REMOVE WIRING DETAIL	KZB	
REV.	DATE	DESCRIPTION	BY	APPR.

REVISION 06 APPR. BY: SCALE: 1=6 1192-E10B-177679

ALL WIRES ARE INCLUDED IN HARNESS. WIRES NOT SHOWN.

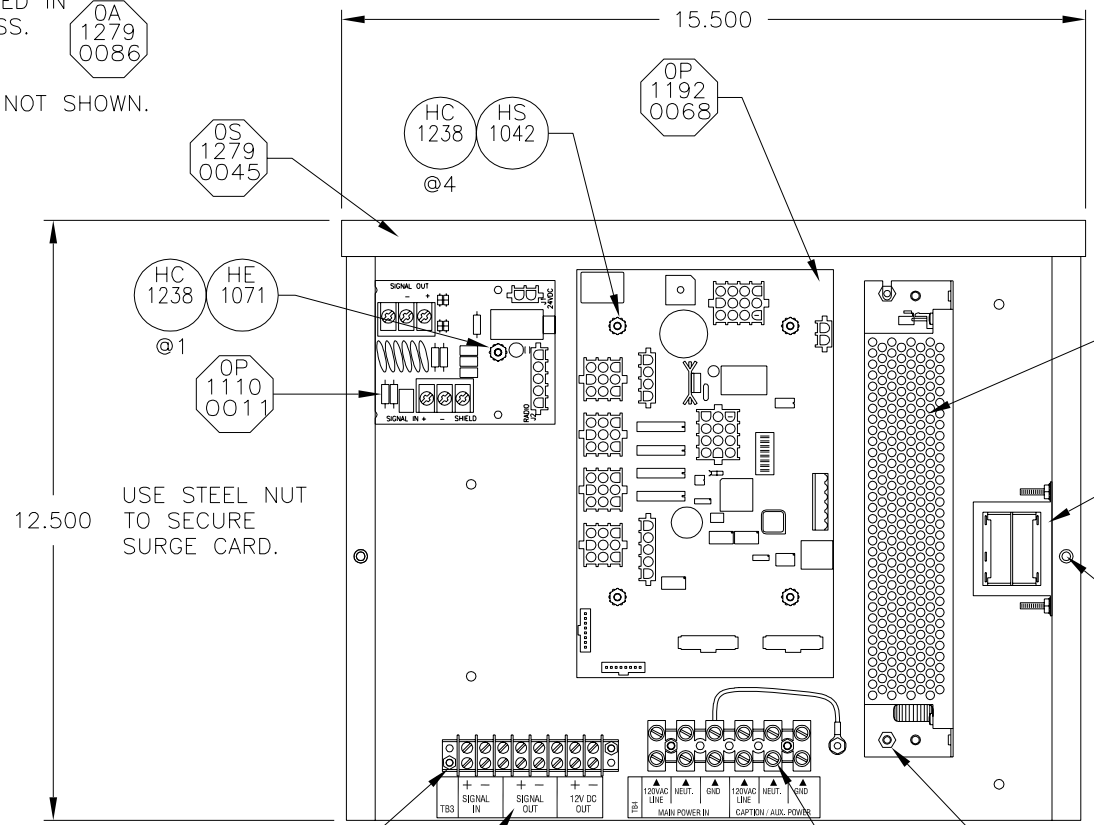

CAP OFF THE FAN WIRES WITH WIRE NUTS. E 1030 @2

APPLY SIGNAL SCHEMATIC TO THE BACK OF THE COVER. USE IT AS A REFERENCE WHEN ROUTING THE WIRES.

MOUNT POWER SUPPLY DIRECTLY TO #6 STUDS AND SECURE WITH NUTS. A 1720

NOTE: MOUNT TRANSFORMER BEFORE INSTALLING POWER SUPPLY OR DRIVER. T 1072

USE STEEL NUT TO SECURE SURGE CARD.

FRONT VIEW

NOTE: TERMINAL LABELS MUST BE ALIGNED WITH TERMINALS AS SHOWN.

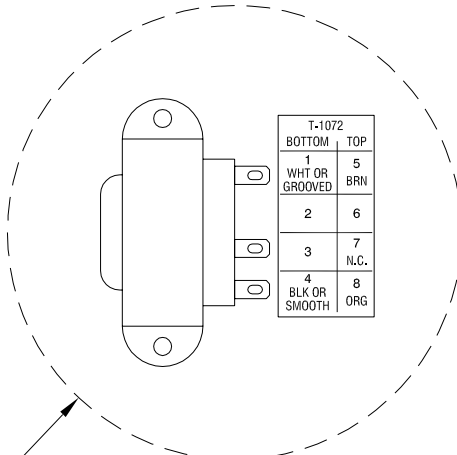

DETAIL: A (2 X SCALE) APPLY LABEL AS SHOWN

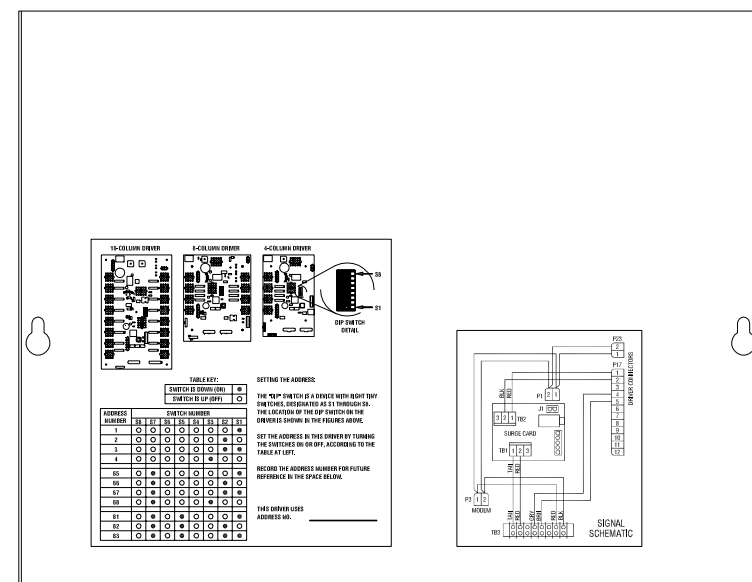

COVER, REAR VIEW

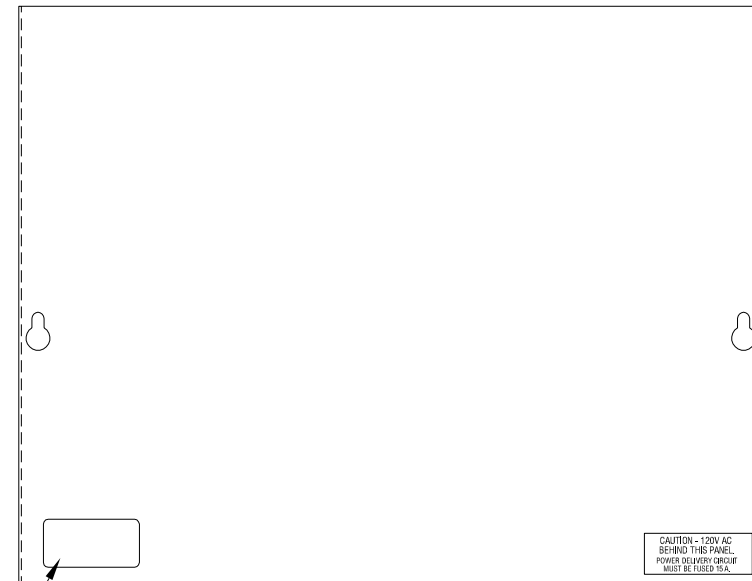

COVER, FRONT VIEW

APPLY THE CAUTION 120V LABEL TO THE FRONT OF THE COVER, DOWN IN THE CORNER.

USE 1/2" LONG STANDOFFS (HE-1071) AS NUTS ON TERMINAL BLOCKS AND GROUND LUG

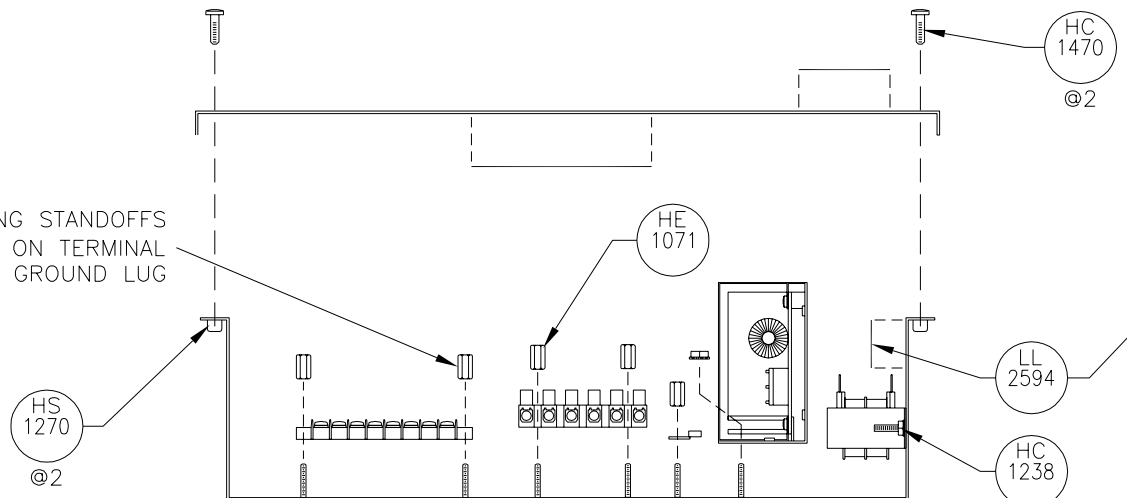

BOTTOM VIEW

REV.	DATE	DESCRIPTION	BY	APPR.	REV.	DATE	DESCRIPTION	BY	APPR.	REV.	DATE	DESCRIPTION	BY	APPR.
08	27 DEC 04	UPDATED LL-2564 LABELS.	MGL		04	10 JUL 03	REPLACED DRIVER MOUNTING HDWR WITH HC-1364 @4 AND SURGE CARD MOUNTING HDWR WITH HC-1238 @1.	MGL		07	29 DEC 03	MOVED TRANSFORMER AND ADDED LL-2594.	MGL	
07	29 DEC 03	MOVED TRANSFORMER AND ADDED LL-2594.	MGL		03	28 APR 03	ADDED T-1072 AND HDWE. INCREASED WIDTH OF BOX AND COVER BY 0.50"	AVB		06	22 OCT 03	CHANGED HC-1364 @4 TO HC-1238 @4 PER ECO-041460.	MGL	
06	22 OCT 03	CHANGED HC-1364 @4 TO HC-1238 @4 PER ECO-041460.	MGL		02	25 FEB 03	CHANGED DRIVER MOUNTING HARDWARE AND SURGE CARD MOUNTING.	AVB		05	14 JUL 03	INSERTED NEW TB-1073 AND ADJUSTED ITS POSITION.	MGL	
05	14 JUL 03	INSERTED NEW TB-1073 AND ADJUSTED ITS POSITION.	MGL		01	03 JAN 03	CHANGED TB-1072 TO TB-1073.	AVB		09	25MAY 06	REMOVED P-1151.	AVB	

THE CONCEPTS EXPRESSED AND DETAILS SHOWN ON THIS DRAWING ARE CONFIDENTIAL AND PROPRIETARY. DO NOT REPRODUCE BY ANY MEANS, INCLUDING ELECTRONICALLY WITHOUT THE EXPRESSED WRITTEN CONSENT OF DAKTRONICS, INC. COPYRIGHT 2002 DAKTRONICS, INC.	
DAKTRONICS, INC. BROOKINGS, SD 57006	
PROJ: ENCLOSED DRIVER, 4-COL MASC	
DES. BY: AVB	DRAWN BY: A VANBEMMEL DATE: 27 NOV 02
REVISION 09	APPR. BY: SCALE: 1=4
1279-E10B-179349	

THIS SCHEMATIC REPRESENTS THE INTERCONNECT OF THE MASTER DRIVER TO OTHER DRIVERS/TNMC'S IN A MULTI DRIVER SCOREBOARD CONFIGURATION. SEE THE PRE-PAINT ASSEMBLY DRAWING AND/OR THE FINAL ASSEMBLY DRAWING FOR THE PART NUMBERS OF THE INTERCONNECT HARNESES NEEDED AND INSTALLATION INSTRUCTIONS.

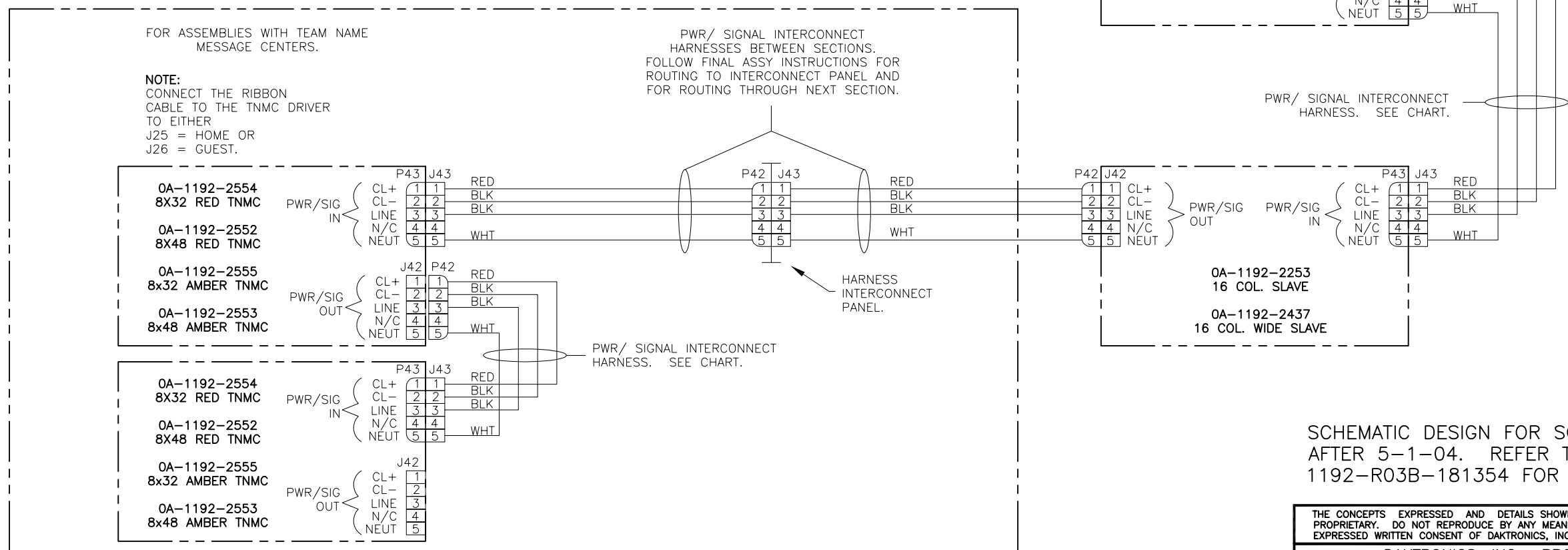
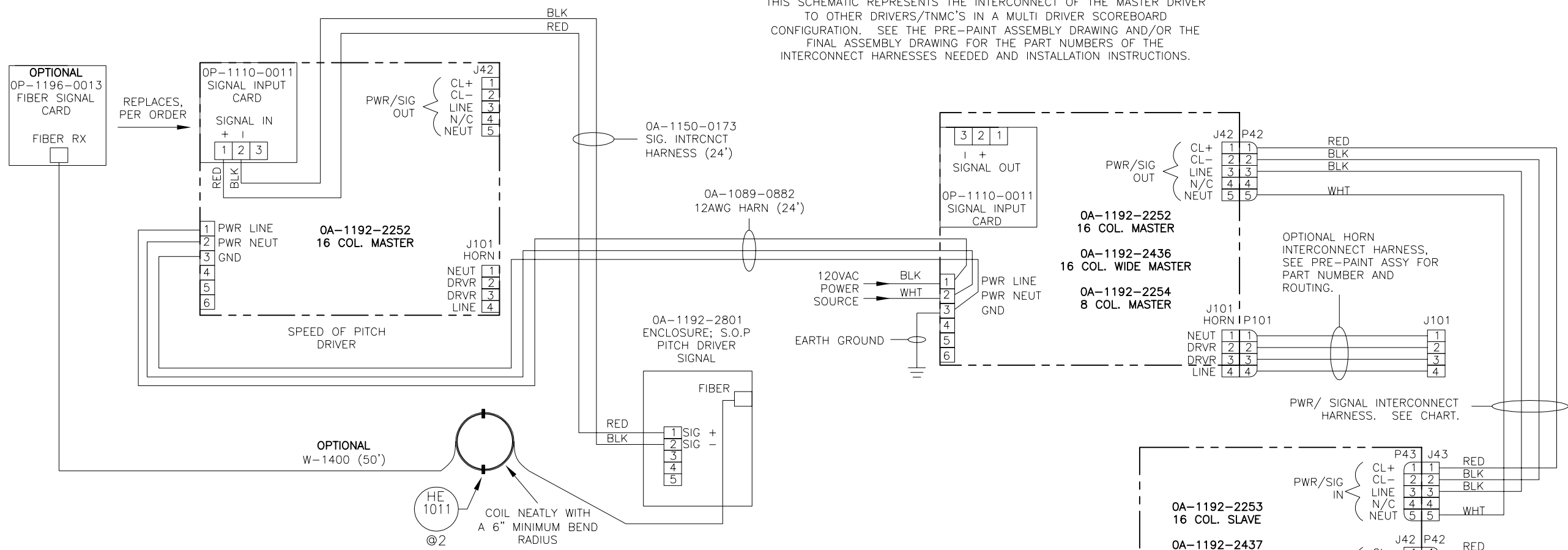

SCHEMATIC DESIGN FOR SCOREBOARDS BUILT AFTER 5-1-04. REFER TO DWG 1192-R03B-181354 FOR OLDER SCHEMATIC.

THE CONCEPTS EXPRESSED AND DETAILS SHOWN ON THIS DRAWING ARE CONFIDENTIAL AND PROPRIETARY. DO NOT REPRODUCE BY ANY MEANS, INCLUDING ELECTRONICALLY WITHOUT THE EXPRESSED WRITTEN CONSENT OF DAKTRONICS, INC. COPYRIGHT 2002 DAKTRONICS, INC.

DAKTRONICS, INC. BROOKINGS, SD 57006			
PROJ: OUTDOOR LED SCOREBOARDS			
TITLE: SCHEMATIC; BASEBALL W/ S.O.P, GEN III, OPTIONAL TNMC			
DES. BY: MMILLER		DRAWN BY: MMILLER	
DATE: 13 FEB 04		REVISION	
APPR. BY:		SCALE: NONE	
1192-R03B-204264			

REV.	DATE	DESCRIPTION	BY	APPR.
00				

THIS SCHEMATIC REPRESENTS THE INTERCONNECT OF THE MASTER DRIVER TO OTHER DRIVERS/ TNMC'S IN A MULTI DRIVER SCOREBOARD CONFIGURATION. SEE PRE PAINT ASSEMBLY DRAWING FOR THE FINAL ASSEMBLY DRAWING FOR PART NUMBERS OF THE INTERCONNECT HARNESSES NEEDED AND INSTALLATION INSTRUCTIONS.

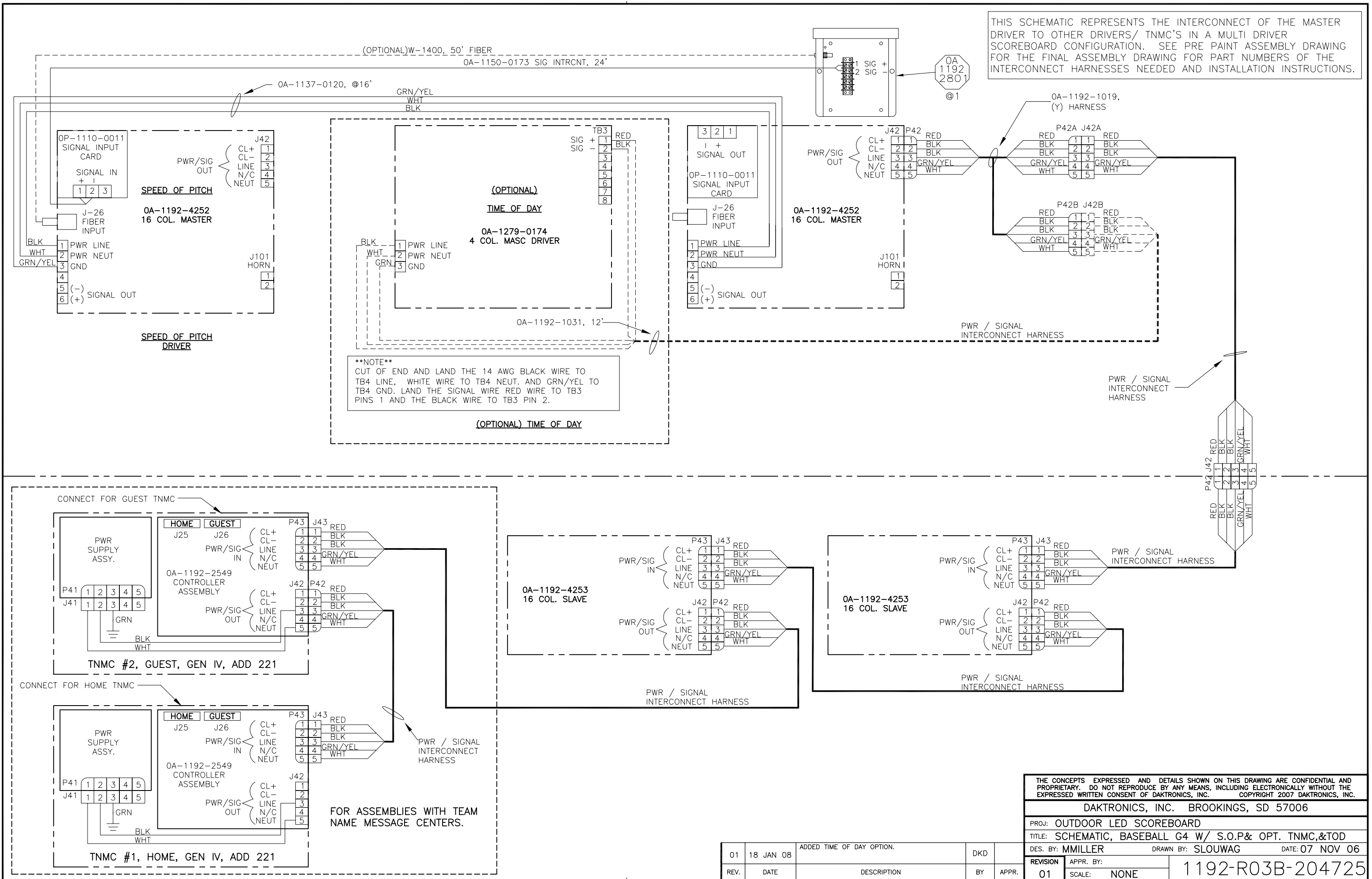

****NOTE****
 CUT OF END AND LAND THE 14 AWG BLACK WIRE TO TB4 LINE, WHITE WIRE TO TB4 NEUT. AND GRN/YEL TO TB4 GND. LAND THE SIGNAL WIRE RED WIRE TO TB3 PINS 1 AND THE BLACK WIRE TO TB3 PIN 2.

THE CONCEPTS EXPRESSED AND DETAILS SHOWN ON THIS DRAWING ARE CONFIDENTIAL AND PROPRIETARY. DO NOT REPRODUCE BY ANY MEANS, INCLUDING ELECTRONICALLY WITHOUT THE EXPRESSED WRITTEN CONSENT OF DAKTRONICS, INC. COPYRIGHT 2007 DAKTRONICS, INC.				
DAKTRONICS, INC. BROOKINGS, SD 57006				
PROJ: OUTDOOR LED SCOREBOARD				
TITLE: SCHEMATIC, BASEBALL G4 W/ S.O.P& OPT. TNMC,&TOD				
DES. BY: MMILLER		DRAWN BY: SLOWWAG		DATE: 07 NOV 06
REVISION	APPR. BY:	1192-R03B-204725		
01	SCALE: NONE			

REV.	DATE	DESCRIPTION	BY	APPR.
01	18 JAN 08	ADDED TIME OF DAY OPTION.	DKD	

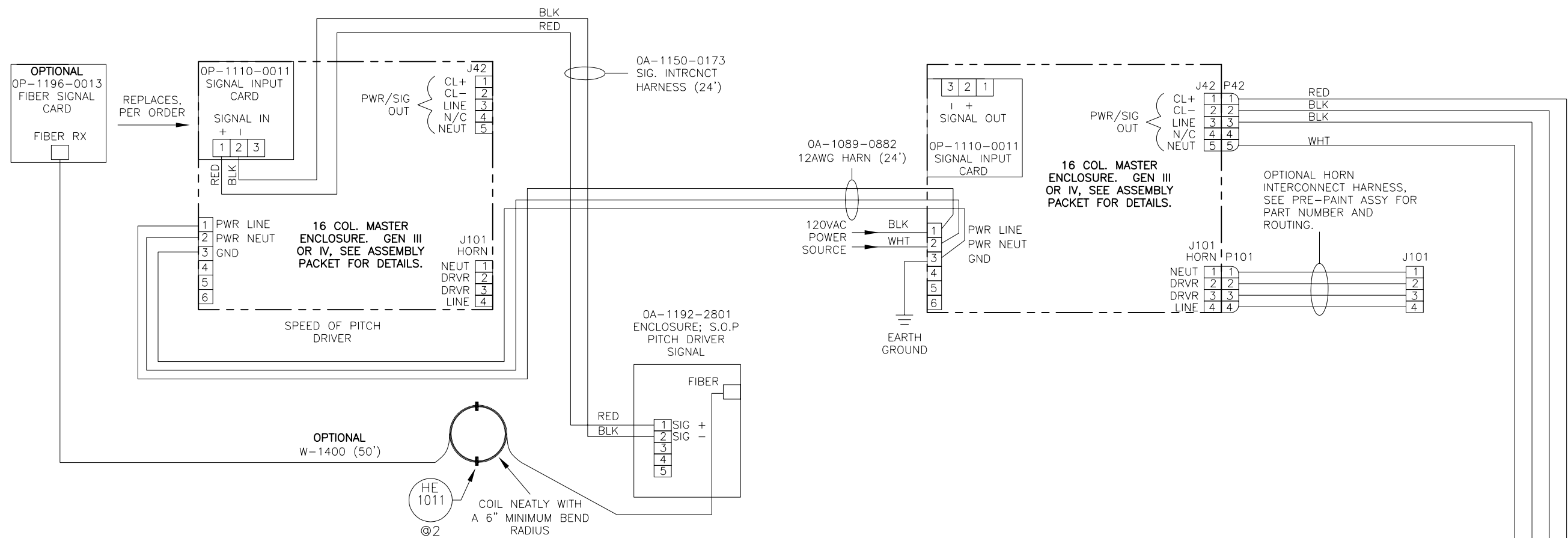

FOR ASSEMBLIES WITH TEAM NAME MESSAGE CENTERS.

NOTE:
CONNECT THE RIBBON CABLE TO THE TNMC DRIVER TO EITHER
J25 = HOME OR
J26 = GUEST.

PWR/ SIGNAL INTERCONNECT HARNESSES BETWEEN SECTIONS. FOLLOW FINAL ASSY INSTRUCTIONS FOR ROUTING TO INTERCONNECT PANEL AND FOR ROUTING THROUGH NEXT SECTION.

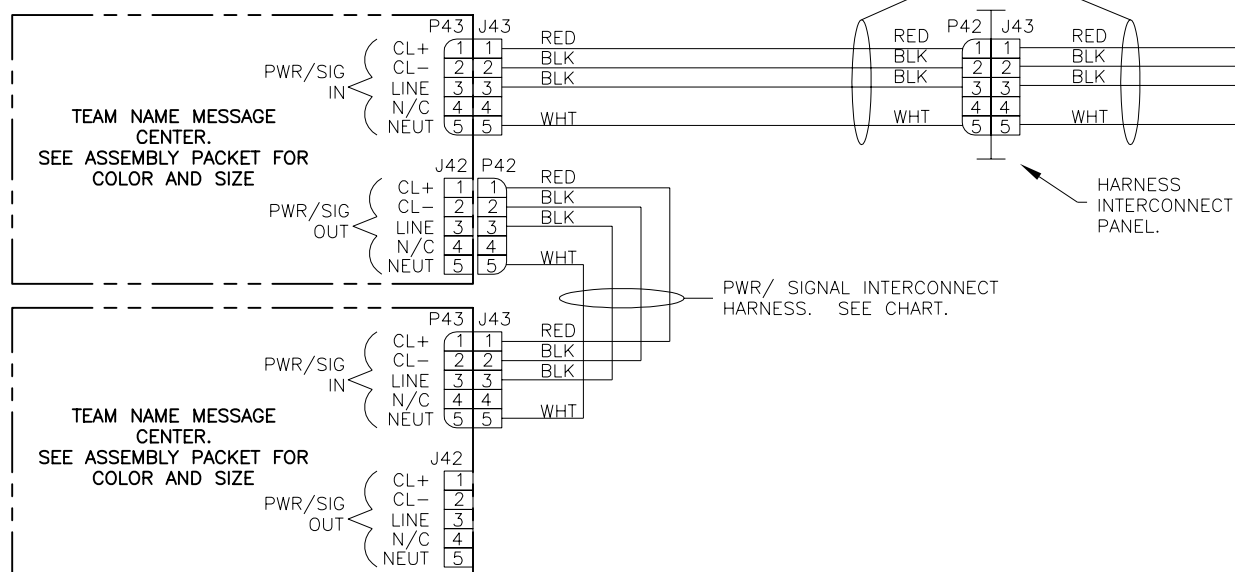

PWR/ SIGNAL INTERCONNECT HARNESS. SEE CHART.

THE CONCEPTS EXPRESSED AND DETAILS SHOWN ON THIS DRAWING ARE CONFIDENTIAL AND PROPRIETARY. DO NOT REPRODUCE BY ANY MEANS, INCLUDING ELECTRONICALLY WITHOUT THE EXPRESSED WRITTEN CONSENT OF DAKTRONICS, INC. COPYRIGHT 2004 DAKTRONICS, INC.

DAKTRONICS, INC. BROOKINGS, SD 57006

PROJ: OUTDOOR LED SCOREBOARDS

TITLE: SCHEMATIC; GEN III & IV OD LED, 1DRVR W/ S.O.P.

DES. BY: RTAGTOW DRAWN BY: RTAGTOW DATE: 30 APR 04

REVISION 00 APPR. BY: MMILLER SCALE: NONE

1192-R03B-210454

REV.	DATE	DESCRIPTION	BY	APPR.

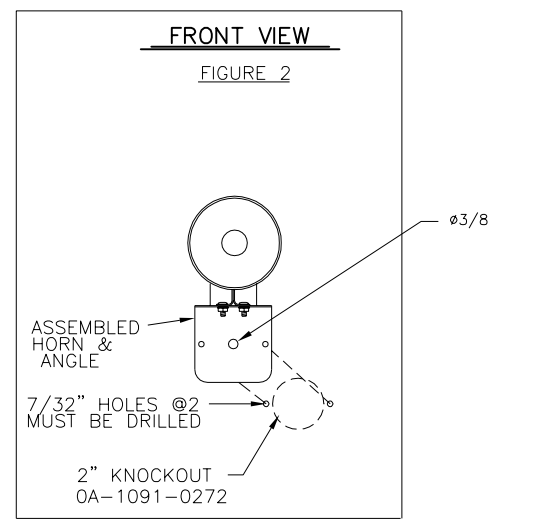
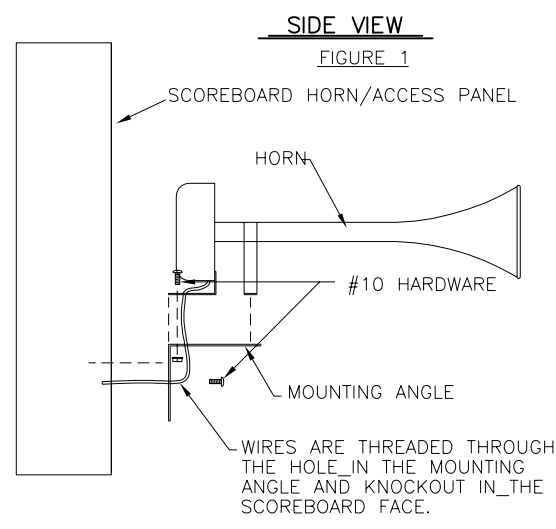

**GEN IV LED DRIVERS
SYSTEM BUILT FROM
JAN 2007 TO PRESENT**

FOR COMPLETE INSTALLATION INSTRUCTIONS, REFER TO ED-10006.

MOUNTING ENCLOSURE TO INSIDE OF SCOREBOARD

1. OPEN THE HORN PANEL AND LOCATE THE ENTRANCE PLATE. DRILL TWO 5/32" HOLES 4 INCHES APART IN THE BACK OF THE SCOREBOARD NEAR THE ENTRANCE PLATE.
2. ATTACH THE ENCLOSURE TO THE INSIDE OF THE SCOREBOARD OVER THE 5/32" HOLES USING #10 TAPPING SCREWS. ATTACH THE PLATE ASSEMBLY TO THE ENCLOSURE USING #10 HARDWARE. REMOVE 2" KNOCKOUT IN THE HORN PANEL AND DRILL TWO 7/32" HOLES USING THE TEMPLATE DRAWING A-83502. IF NO KNOCKOUT EXISTS, USE THE TEMPLATE TO DRILL ONE 8/32" HOLE AND TWO 7/32" HOLES IN THE PANEL.

MOUNTING HORN TO SCOREBOARD FACE

1. THREAD THE TWO GRAY WIRES FROM THE HORN THROUGH THE TOP OF THE MOUNTING ANGLE.
2. ATTACH THE HORN TO THE MOUNTING ANGLE USING THE HARDWARE PROVIDED (FIGURE 1).
3. INSERT THE BUSHING INTO THE 3/8" HOLE IN THE MOUNTING ANGLE.
4. MOUNT HORN/ANGLE ASSEMBLY TO THE FACE OF THE SCOREBOARD OVER THE 2" KNOCKOUT AND 7/32" HOLES USING #10 HARDWARE PROVIDED.
5. OPEN THE HORN PANEL AND REMOVE THE COVER FROM THE ENCLOSURE.
6. USING THE WIRE NUTS PROVIDED CONNECT ONE GRAY WIRE FROM THE HORN TO THE BLACK WIRE FROM THE PLATE ASSEMBLY. CONNECT THE OTHER GRAY WIRE TO THE RED WIRE (FIGURE 3).

7. STEPS FOR INSTALLING THE OA-1192-1685, HORN INTERFACE KIT. (FIGURE 3)

- (A) MOUNT OP-1150-0246 HORN SWITCH CARD USING HS-1042 SPACER & HC-1238 LOCK NUT.
 - (B) PLUG SIGNAL CABLE P18 INTO J18 ON THE DRIVER AND P2 INTO J2 OF OP-1150-0246.
 - (C) PLUG POWER A3-P1 POWER HARNESS INTO A3-J1 OF THE HORN INTERFACE CARD.
 - (D) PLUG HORN CABLE P3 INTO J3 OF THE OP-1150-0246 AND THE OPPOSITE END ON TO THE HORN.
8. ATTACH THE COVER TO THE ENCLOSURE USING #10 HARDWARE.
 9. CLOSE AND SECURE THE HORN PANEL.

**GEN III LED DRIVERS
SYSTEMS BUILT FROM
MAR 2006 TO JAN 2007**

FOR COMPLETE INSTALLATION INSTRUCTIONS, REFER TO ED-10006.

MOUNTING ENCLOSURE TO INSIDE OF SCOREBOARD

1. OPEN THE HORN PANEL AND LOCATE THE ENTRANCE PLATE. DRILL TWO 5/32" HOLES 4 INCHES APART IN THE BACK OF THE SCOREBOARD NEAR THE ENTRANCE PLATE.
2. ATTACH THE ENCLOSURE TO THE INSIDE OF THE SCOREBOARD OVER THE 5/32" HOLES USING #10 TAPPING SCREWS. ATTACH THE PLATE ASSEMBLY TO THE ENCLOSURE USING #10 HARDWARE. REMOVE 2" KNOCKOUT IN THE HORN PANEL AND DRILL TWO 7/32" HOLES USING THE TEMPLATE DRAWING A-83502. IF NO KNOCKOUT EXISTS, USE THE TEMPLATE TO DRILL ONE 8/32" HOLE AND TWO 7/32" HOLES IN THE PANEL.
3. CLEAN METAL AND MOUNT OP-1150-0246 IN DRIVER ENCLOSURE WITH ADHESIVE TAPE PROVIDED.

MOUNTING HORN TO SCOREBOARD FACE

1. THREAD THE TWO GRAY WIRES FROM THE HORN THROUGH THE TOP OF THE MOUNTING ANGLE.
2. ATTACH THE HORN TO THE MOUNTING ANGLE USING THE HARDWARE PROVIDED (FIGURE 1).
3. INSERT THE BUSHING INTO THE 3/8" HOLE IN THE MOUNTING ANGLE.
4. MOUNT HORN/ANGLE ASSEMBLY TO THE FACE OF THE SCOREBOARD OVER THE 2" KNOCKOUT AND 7/32" HOLES USING #10 HARDWARE PROVIDED.
5. OPEN THE HORN PANEL AND REMOVE THE COVER FROM THE ENCLOSURE.
6. USING THE WIRE NUTS PROVIDED CONNECT ONE GRAY WIRE FROM THE HORN TO THE BLACK WIRE FROM THE PLATE ASSEMBLY. CONNECT THE OTHER GRAY WIRE TO THE RED WIRE (FIGURE 3).

7. CONNECT THE PLUG FROM THE PLATE ASSEMBLY TO THE HORN JACK ON THE HORN INTERFACE CARD.
 - CONNECT THE POWER HARNESS (P101) INTO (J101) OF THE DRIVER ENCLOSURE AND J1 ON THE HORN INTERFACE CARD.
 - PLUG THE HORN SIGNAL HARNESS IN TO J18 OF THE DRIVER & J2 OF THE HORN INTERFACE CARD.

8. ATTACH THE COVER TO THE ENCLOSURE USING #10 HARDWARE.
9. CLOSE AND SECURE THE HORN PANEL.

**GEN I & II LED DRIVERS
SYSTEMS BUILT FROM
2001 TO MAR 2006**

FOR COMPLETE INSTALLATION INSTRUCTIONS, REFER TO ED-10006.

MOUNTING ENCLOSURE TO INSIDE OF SCOREBOARD

1. OPEN THE HORN PANEL AND LOCATE THE ENTRANCE PLATE. DRILL TWO 5/32" HOLES 4 INCHES APART IN THE BACK OF THE SCOREBOARD NEAR THE ENTRANCE PLATE.
2. ATTACH THE ENCLOSURE TO THE INSIDE OF THE SCOREBOARD OVER THE 5/32" HOLES USING #10 TAPPING SCREWS. ATTACH THE PLATE ASSEMBLY TO THE ENCLOSURE USING #10 HARDWARE. REMOVE 2" KNOCKOUT IN THE HORN PANEL AND DRILL TWO 7/32" HOLES USING THE TEMPLATE DRAWING A-83502. IF NO KNOCKOUT EXISTS, USE THE TEMPLATE TO DRILL ONE 8/32" HOLE AND TWO 7/32" HOLES IN THE PANEL.

MOUNTING HORN TO SCOREBOARD FACE

1. THREAD THE TWO GRAY WIRES FROM THE HORN THROUGH THE TOP OF THE MOUNTING ANGLE.
2. ATTACH THE HORN TO THE MOUNTING ANGLE USING THE HARDWARE PROVIDED (FIGURE 1).
3. INSERT THE BUSHING INTO THE 3/8" HOLE IN THE MOUNTING ANGLE.
4. MOUNT HORN/ANGLE ASSEMBLY TO THE FACE OF THE SCOREBOARD OVER THE 2" KNOCKOUT AND 7/32" HOLES USING #10 HARDWARE PROVIDED.
5. OPEN THE HORN PANEL AND REMOVE THE COVER FROM THE ENCLOSURE.
6. USING THE WIRE NUTS PROVIDED CONNECT ONE GRAY WIRE FROM THE HORN TO THE BLACK WIRE FROM THE PLATE ASSEMBLY. CONNECT THE OTHER GRAY WIRE TO THE RED WIRE (FIGURE 3).

7. CONNECT THE PLUG FROM THE PLATE ASSEMBLY TO THE HORN JACK (J101) HARNESS
8. ATTACH THE COVER TO THE ENCLOSURE USING #10 HARDWARE.
9. CLOSE AND SECURE THE HORN PANEL.

FIGURE 3
HORN CONNECTION

SEE DWG-302328 DETAIL (A) FOR MORE DETAILED VIEW OF DRIVER

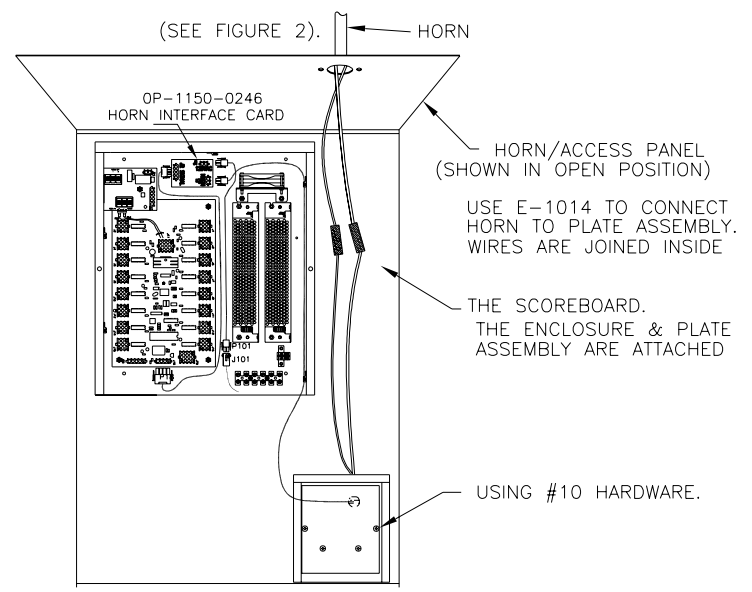
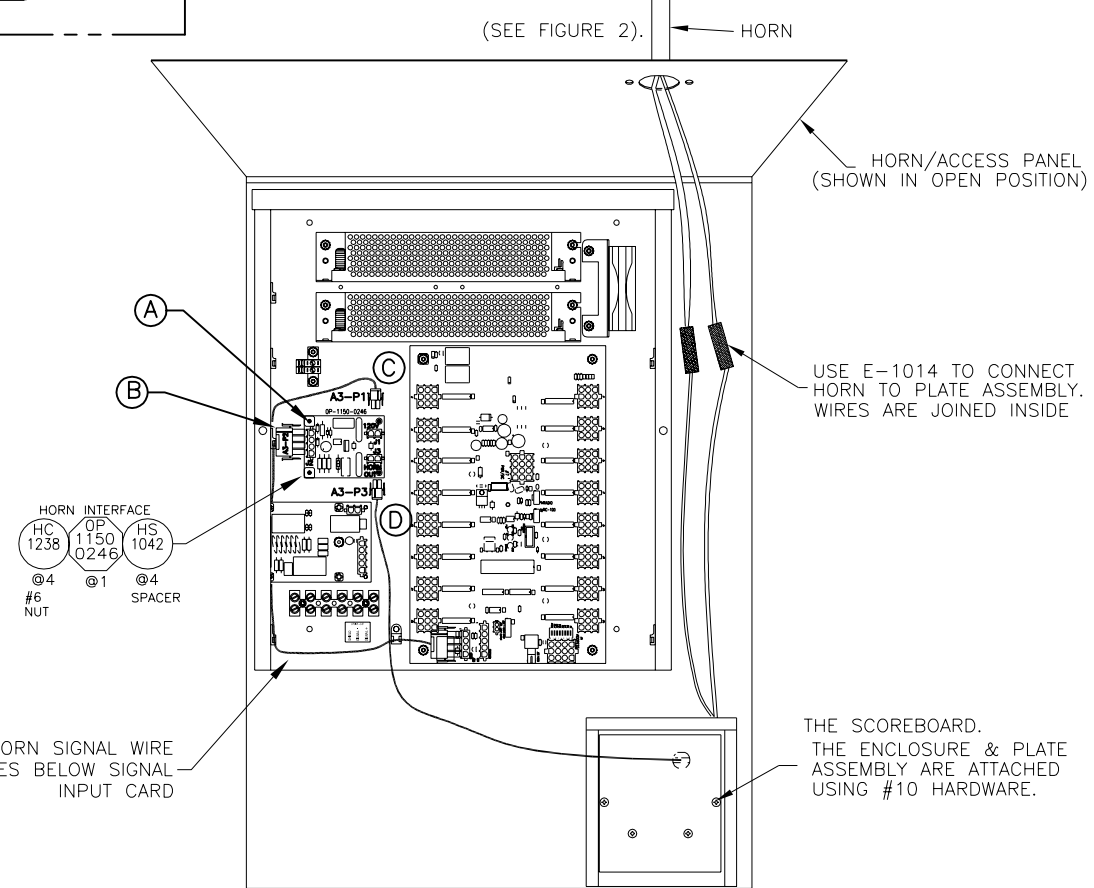

FIGURE 3
HORN CONNECTION

SEE DWG-302328 DETAIL (B) FOR MORE DETAILED VIEW OF DRIVER

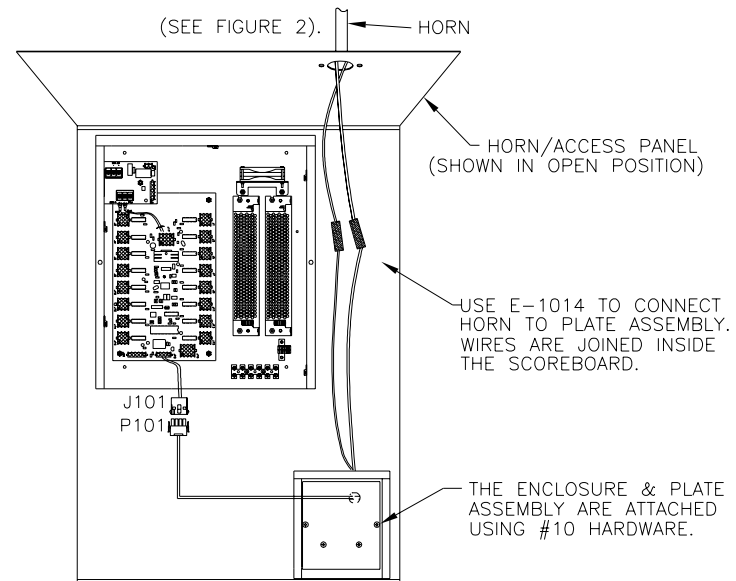

FIGURE 3
HORN CONNECTION

REV.	DATE	DESCRIPTION	BY	APPR.
02	13 AUG 07	ADDED GEN IV DRIVER	DMD	
01	30 MAY 06	ADDED HORN INTERFACE CARD	DMD	

THE CONCEPTS EXPRESSED AND DETAILS SHOWN ON THIS DRAWING ARE CONFIDENTIAL AND PROPRIETARY. DO NOT REPRODUCE BY ANY MEANS, INCLUDING ELECTRONICALLY WITHOUT THE EXPRESSED WRITTEN CONSENT OF DAKTRONICS, INC. COPYRIGHT 2006 DAKTRONICS, INC.				
DAKTRONICS, INC. BROOKINGS, SD 57006				
PROJ: STANDARD SCOREBOARDS				
TITLE: F.ASSY; 12V DC HORN MOUNTING, OUTDOOR LED SCBD				
DES. BY:		DRAWN BY: JMOEN		DATE: 20 JUN 96
REVISION	APPR. BY:	1091-E10B-242731		
02	SCALE: NONE			

ADDRESS SETTINGS:
DRIVER: A1
ADDRESS: 3
SET THE FOLLOWING SWITCHES TO ON: 1 AND 2

BA-2023-11
SPECIFICATIONS FOR LL-2306
MODEL: BA-2023-11
VOLTS: 120V AC
AMPS: 1.7A
MAX WATTS: 300W

OR

BA-2023-21
SPECIFICATIONS FOR LL-2306
MODEL: BA-2023-21
VOLTS: 120V AC
AMPS: 1.7A
MAX WATTS: 300W

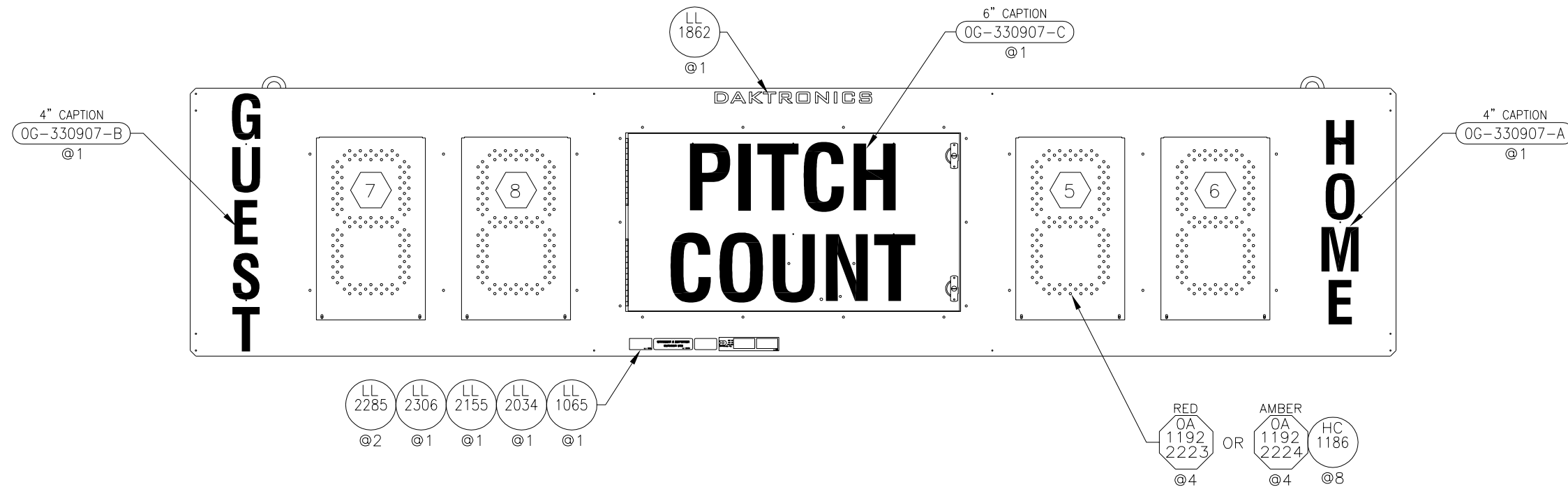

SCHEMATIC/DIGIT DESIGNATION
1192-R03B-285779

ASSEMBLY PACKETS:

OA-1192-3469...F. ASSY; BA-2023-11, G4
 OA-1192-3470...F. ASSY; BA-2023-21, G4
 .OA-1192-3473...PRE-PAINT; BA-2023
 ..OS-1192-3372...CABINET; BA-2023

THE CONCEPTS EXPRESSED AND DETAILS SHOWN ON THIS DRAWING ARE CONFIDENTIAL AND PROPRIETARY. DO NOT REPRODUCE BY ANY MEANS, INCLUDING ELECTRONICALLY WITHOUT THE EXPRESSED WRITTEN CONSENT OF DAKTRONICS, INC. COPYRIGHT 2008 DAKTRONICS, INC.			
DAKTRONICS, INC. BROOKINGS, SD 57006			
PROJ: OUTDOOR LED SCOREBOARDS			
TITLE: F. ASSY: BA-2023-11/-21- G4			
DES. BY: KDRAGT		DRAWN BY: KDRAGT	
DATE: 18 JAN 08		DATE: 18 JAN 08	
REVISION	APPR. BY:	1192-E10B-331009	
01	SCALE: 1=12		

REV.	DATE	DESCRIPTION	BY	APPR.
01	05 MAR 08	UPDATED DIGIT DESIGNATION	KDD	

Appendix B: Eyebolts

Eyebolts [ED-7244](#)

EYEBOLTS

Almost every display that leaves Daktronics is equipped with eyebolts for lifting the display. There are two standard sizes of eyebolts: 1/2" and 5/8".

Load Increase Factor: The load increases as the lift angle (θ) decreases. The allowable load on the eyebolts also decreases with the lift angle due the bending stress on the eyebolts. In sum, the smaller the angle between the cable and the top of the display, the lighter the sign must be to safely lift it. *Do NOT attempt to lift the display when the lift angle is less than 30 degrees.*

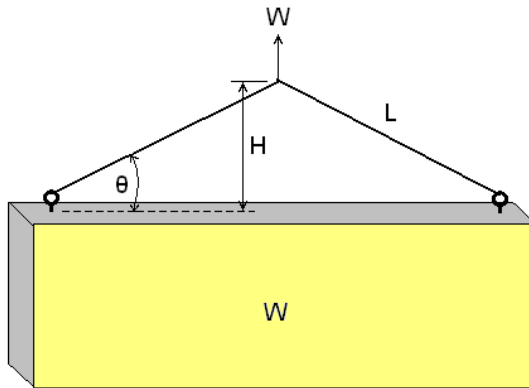

W= Weight of sign or Section
 H= Distance between top of sign and lift point
 L= Length of cable on one side
 θ = Angle between sign and cable

Horizontal Angle	Load Angle Factor (L/H)
90	1.00
60	1.155
50	1.305
45	1.414
30	2.00

θ	1/2"		5/8"	
	Line Load	Weight/Anchor	Line Load	Weight/Anchor
90	2600	2600	4000	4000
60	1500	1299	3300	2858
45	650	460	1000	707
30	520	260	800	400

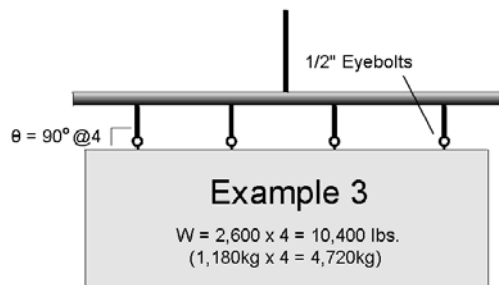
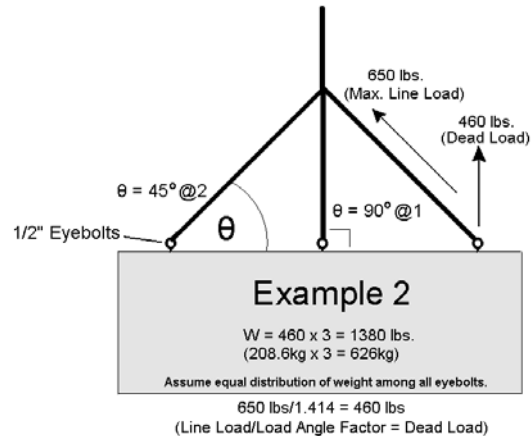
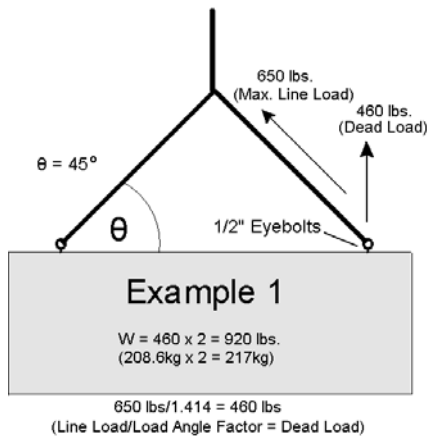

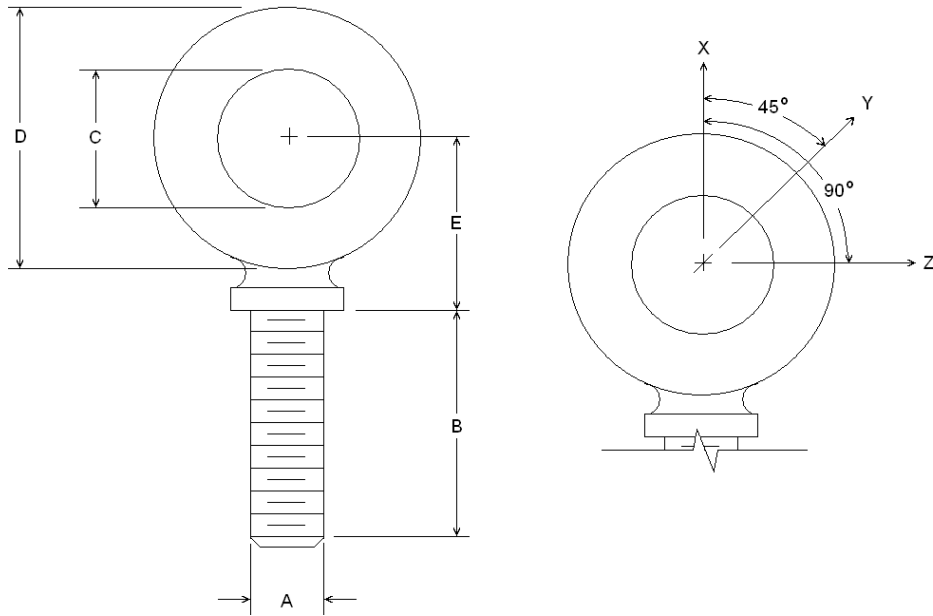

A	B	C	D	E	No.	Min. Proof Load (lbs.)	Min. Break Load (lbs.)	Stocked	Min. Eff. Thrd. Length	Line Loads		
										Wx	Wy	Wz
1/4	1	3/4	1-3/16	25/32	21	600	2,000	Blank 1/4-20	7/8	400	100	80
3/8	1-1/4	1	1-21/32	1-3/16	23	2,100	5,000	Blank 3/8-16	1-1/8	1,400	350	250
1/2	1-1/2	1-3/16	2-1/16	1-13/32	25	3,900	9,200	Blank 1/2-13	1-11/32	2,600	650	520
9/16	1-5/8	1-9/32	2-13/16	1-17/32	26	4,500	11,830	Blank 9/16-12	1-3/8	3,000	750	600
5/8	1-3/4	1-3/8	2-1/2	1-11/16	27	6,000	14,700	Blank 5/8-11	1-9/16	4,000	1,000	800
3/4	2	1-1/2	2-13/16	1-13/16	28	9,000	21,700	Blank 3/4-10	1-5/8	6,000	1,500	1,200
7/8	2-1/4	1-11/16	3-1/4	2-1/16	29	10,000	30,000	Blank 7/8-9	1-13/16	6,600	1,670	1,330
1	2-1/2	1-13/16	3-9/16	2-5/16	30	12,000	39,400	Blank 1-8	2-1/16	8,000	2,000	1,600
1-1/2	3-1/2	2-9/16	5-1/2	3-5/32	34	27,000	91,300	Blank 1-1/2-6	3	17,800	4,500	3,600

- A. Do not use eyebolts on angular lifts unless absolutely necessary. For angular lifts, the shoulder pattern eyebolt is preferred.
- B. Load should always be applied to eyebolts in the plane of the eye, not at some angle to this plane.
- C. Shoulder eyebolts must be properly seated (should bear firmly against the mating part), otherwise the working loads must be reduced to those indicated for regular eyebolts. A washer or spacer may be required to put the plane of the eye in the direction of the load when the shoulder is seated.
- D. No load greater than the safe working load listed in the data table should be used.
- E. To obtain the greatest strength from the eyebolt, it must fit reasonably tight in its mounting hole to prevent accidental unscrewing due to twist of cable.
- F. Eyebolts should never be painted or otherwise coated when used for lifting. Such coatings may cover potential flaws in the eyebolt.
- G. To attain the safe working loads listed for regular eyebolts, 90% of the thread length must be engaged.

Appendix C: Daktronics Warranty and Limitation of Liability

**DAKTRONICS
WARRANTY AND LIMITATION OF LIABILITY**

This Warranty and Limitation of Liability (the "Warranty") sets forth the warranty provided by Daktronics with respect to the Equipment. By accepting delivery of the Equipment, Purchaser agrees to be bound by and accept these terms and conditions. All defined terms within the Warranty shall have the same meaning and definition as provided elsewhere in the Agreement.

DAKTRONICS WILL ONLY BE OBLIGATED TO HONOR THE WARRANTY SET FORTH IN THESE TERMS AND CONDITIONS UPON RECEIPT OF FULL PAYMENT FOR THE EQUIPMENT.

1. Warranty Coverage

A. Daktronics warrants to the original end-user that the Equipment will be free from Defects (as defined below) in materials and workmanship for a period of one (1) year (the "Warranty Period"). The warranty period shall commence on the earlier of: (i) four weeks from the date that the equipment leaves Daktronics' facility; or (ii) Substantial Completion as defined herein. The warranty period shall expire on the first anniversary of the commencement date.

"Substantial Completion" means the operational availability of the Equipment to the Purchaser in accordance with the Equipment's specifications, without regard to punch-list items, or other non-substantial items which do not affect the operation of the Equipment.

B. Daktronics' obligation under this Warranty is limited to, at Daktronics' option, replacing or repairing, any Equipment or part thereof that is found by Daktronics not to conform to the Equipment's specifications. Unless otherwise directed by Daktronics, any defective part or component shall be returned to Daktronics for repair or replacement. Daktronics may, at its option, provide on-site warranty service. Daktronics shall have a reasonable period of time to make such replacements or repairs and all labor associated therewith shall be performed during regular working hours. Regular working hours are Monday through Friday between 8:00 a.m. and 5:00 p.m. at the location where labor is performed, excluding any holidays observed by either Purchaser or Daktronics.

C. Daktronics shall pay ground transportation charges for the return of any defective component of the Equipment. If returned Equipment is repaired or replaced under the terms of this warranty, Daktronics will prepay ground transportation charges back to Purchaser; otherwise, Purchaser shall pay transportation charges to return the Equipment back to the Purchaser. All returns must be pre-approved by Daktronics before shipment. Daktronics shall not be obligated to pay freight for any unapproved return. Purchaser shall pay any upgraded or expedited transportation charges.

D. Any replacement parts or Equipment will be new or serviceably used, comparable in function and performance to the original part or Equipment, and warranted for the remainder of the Warranty Period. Purchasing additional parts or Equipment from the Seller does not extend this Warranty Period.

E. Defects shall be defined as follows. With regard to the Equipment (excepting LEDs), a "Defect" shall refer to a material variance from the design specifications that prohibit the Equipment from operating for its intended use. With respect to LEDs, "Defects" are defined as LED pixels that cease to emit light. The limited warranty provided by Daktronics does not impose any duty or liability upon Daktronics for partial LED pixel degradation. Nor does the limited warranty provide for the replacement or installation of communication methods including but not limited to, wire, fiber optic cable, conduit, trenching, or for the purpose of overcoming local site interference radio equipment substitutions.

THIS LIMITED WARRANTY IS THE ONLY WARRANTY APPLICABLE TO THE EQUIPMENT AND REPLACES ALL OTHER WARRANTIES OR CONDITIONS, EXPRESS OR IMPLIED, INCLUDING, BUT NOT LIMITED TO, THE IMPLIED WARRANTIES OR CONDITIONS OF MERCHANTABILITY AND FITNESS FOR A PARTICULAR PURPOSE. SPECIFICALLY, EXCEPT AS PROVIDED HEREIN, THE SELLER UNDERTAKES NO RESPONSIBILITY FOR THE QUALITY OF THE EQUIPMENT OR THAT THE EQUIPMENT WILL BE FIT FOR ANY PARTICULAR PURPOSE FOR WHICH PURCHASER MAY BE BUYING THE EQUIPMENT. ANY IMPLIED WARRANTY IS LIMITED IN DURATION TO THE WARRANTY PERIOD. NO ORAL OR WRITTEN INFORMATION, OR ADVICE GIVEN BY THE COMPANY, ITS AGENTS OR EMPLOYEES, SHALL CREATE A WARRANTY OR IN ANY WAY INCREASE THE SCOPE OF THIS LIMITED WARRANTY.

THIS LIMITED WARRANTY IS NOT TRANSFERABLE.

2. Exclusion from Warranty Coverage

The limited warranty provided by Daktronics does not impose any duty or liability upon Daktronics for:

A. Any damage occurring, at any time, during shipment of Equipment unless otherwise provided for in the Agreement. When returning Equipment to Daktronics for repair or replacement, Purchaser assumes all risk of loss or damage, and agrees to use any shipping containers that might be provided by Daktronics and to ship the Equipment in the manner prescribed by Daktronics;

B. Any damage caused by the unauthorized adjustment, repair or service of the Equipment by anyone other than personnel of Daktronics or its authorized repair agents;



C. Damage caused by the failure to provide a continuously suitable environment, including, but not limited to: (i) neglect or misuse, (ii) a failure or sudden surge of electrical power, (iii) improper air conditioning or humidity control, or (iv) any other cause other than ordinary use;

D. Damage caused by fire, flood, earthquake, water, wind, lightning or other natural disaster, strike, inability to obtain materials or utilities, war, terrorism, civil disturbance or any other cause beyond Daktronics' reasonable control;

E. Failure to adjust, repair or replace any item of Equipment if it would be impractical for Daktronics personnel to do so because of connection of the Equipment by mechanical or electrical means to another device not supplied by Daktronics, or the existence of general environmental conditions at the site that pose a danger to Daktronics personnel;

F. Any statements made about the product by salesmen, dealers, distributors or agents, unless such statements are in a written document signed by an officer of Daktronics. Such statements as are not included in a signed writing do not constitute warranties, shall not be relied upon by Purchaser and are not part of the contract of sale;

G. Any damage arising from the use of Daktronics products in any application other than the commercial and industrial applications for which they are intended, unless, upon request, such use is specifically approved in writing by Daktronics; or

H. Any performance of preventive maintenance.

3. Limitation of Liability

Daktronics shall be under no obligation to furnish continued service under this Warranty if alterations are made to the Equipment without the prior written approval of Daktronics.

It is specifically agreed that the price of the Equipment is based upon the following limitation of liability. In no event shall Daktronics (including its subsidiaries, affiliates, officers, directors, employees, or agents) be liable for any special, consequential, incidental or exemplary damages arising out of or in any way connected with the Equipment or otherwise, including but not limited to damages for lost profits, cost of substitute or replacement equipment, down time, lost data, injury to property or any damages or sums paid by Purchaser to third parties, even if Daktronics has been advised of the possibility of such damages. The foregoing limitation of liability shall apply whether any claim is based upon principles of contract, tort or statutory duty, principles of indemnity or contribution, or otherwise.

In no event shall Daktronics be liable to Purchaser or any other party for loss, damage, or injury of any kind or nature arising out of or in connection with this Warranty in excess of the purchase price of the Equipment actually delivered to and paid for by the Purchaser. The Purchaser's remedy in any dispute under this Warranty shall be ultimately limited to the Purchase Price of the Equipment to the extent the Purchase Price has been paid.

4. Assignment of Rights

The Warranty contained herein extends only to the original end-user (which may be the Purchaser) of the Equipment and no attempt to extend the Warranty to any subsequent user-transferee of the Equipment shall be valid or enforceable without the express written consent of Daktronics.

5. Dispute Resolution

Any dispute between the parties will be resolved exclusively and finally by arbitration administered by the American Arbitration Association ("AAA") and conducted under its rules, except as otherwise provided below. The arbitration will be conducted before a single arbitrator. The arbitration shall be held in Brookings, South Dakota. Any decision rendered in such arbitration proceedings will be final and binding on each of the parties, and judgment may be entered thereon in any court of competent jurisdiction. This arbitration agreement is made pursuant to a transaction involving interstate commerce, and shall be governed by the Federal Arbitration Act.

6. Governing Law

The rights and obligations of the parties under this warranty shall not be governed by the provisions of the United Nations Convention on Contracts for the International Sales of Goods of 1980. Both parties consent to the application of the laws of the State of South Dakota to govern, interpret, and enforce all of Purchaser and Daktronics rights, duties, and obligations arising from, or relating in any manner to, the subject matter of this Warranty, without regard to conflict of law principles.

7. Availability of Extended Service Agreement

For Purchaser's protection, in addition to that afforded by the warranties set forth herein, Purchaser may purchase extended warranty services to cover the Equipment. The Extended Service Agreement, available from Daktronics, provides for electronic parts repair and/or on-site labor for an extended period from the date of expiration of this warranty. Alternatively, an Extended Service Agreement may be purchased in conjunction with this warranty for extended additional services. For further information, contact Daktronics Customer Service at 1-877-605-1116.