

Daktronics Tuff Sport[®] Indoor Tennis LED Scoreboards

Display Manual

ED-16309

Rev 6 – 16 July 2012

DAKTRONICS

Models			
	TN-2501	*	TN-2550
	TN-2503	*	TN-2551
	TN-2504	*	TN-2552
	TN-2505	*	TN-2553

*Discontinued

Please fill in the information below for your display; use it for reference when calling Daktronics for assistance.

Scoreboard Serial No. _____

Scoreboard Model No. _____

Date Installed _____

DAKTRONICS, INC.

Copyright © 2006-2012

All rights reserved. While every precaution has been taken in the preparation of this manual, the publisher assumes no responsibility for errors or omissions. No part of this book covered by the copyrights hereon may be reproduced or copied in any form or by any means – graphic, electronic, or mechanical, including photocopying, taping, or information storage and retrieval systems – without written permission of the publisher.

All Sport® , DakTennis™ , PanaView®, Tuff Sport®, and UniView® are trademarks of Daktronics, Inc.

Table of Contents

Section 1:	Introduction	1
1.1	Scoreboard Controllers.....	1
1.2	Scoreboard Label.....	2
1.3	Model Number	2
1.4	Resources.....	2
1.5	Daktronics Nomenclature	3
1.6	Product Safety Approval.....	3
Section 2:	Specifications.....	5
Section 3:	Mechanical Installation	7
3.1	Lifting the Scoreboard	7
3.2	Scoreboard Mounting (Single- and Multi-Court Models)	8
3.3	Suspension Mounting Kit (Single-Court Models Only).....	8
3.4	Ad Panel Mounting.....	9
3.5	Scoreboard Protective Devices	9
Section 4:	Electrical Installation	11
4.1	Installation Overview	11
4.2	Power	14
	Grounding.....	14
4.3	Power-On Self-Test (POST)	14
	Radio Settings.....	14
4.4	Single-Court Signal Connection	15
4.5	Multi-Court Scoreboard Signal Connection	15
Section 5:	Scoreboard Troubleshooting	17
5.1	Troubleshooting Table.....	17
5.2	Component Location & Access	19
5.3	Replacing Digits	19
	PanaView	20
	UniView	21
5.4	LED Drivers	22
	Replacing a Driver	24
	Setting the Driver Address	24
	Multiple Drivers.....	24
5.5	Segmentation and Digit Designation.....	25
5.6	Schematics.....	25
5.7	Replacement Parts List	25
5.8	Daktronics Exchange and Repair & Return Programs.....	26
	Exchange Program.....	26
	Repair & Return Program	27
	Daktronics Warranty and Limitation of Liability	27
Section 6:	Scoreboard Options	29
6.1	Radio Control.....	29

6.2	Team Name Message Centers	29
Section 7:	TNMC Troubleshooting & Maintenance	31
7.1	Display Overview	31
7.2	Initialization Information at Startup	32
7.3	Display Troubleshooting Table	32
7.4	Power & Signal Summary	33
7.5	Component Locations & Access	33
7.6	Display Drivers.....	33
	Diagnostic LEDs	34
	Replacing a Driver	34
7.7	Modules.....	35
	Replacing Modules	35
7.8	Power Supplies	36
	Replacing a Power Supply	36
7.9	Display Maintenance	36
7.10	Replacement Parts List	36
Appendix A:	Component Location Drawings.....	37
Appendix B:	Scoreboard Options	39
Appendix C:	Schematic Drawings	41
Appendix D:	Additional Reference Drawings.....	43
Appendix E:	Daktronics Warranty and Limitation of Liability	45

Section 1: Introduction

This manual explains the installation and maintenance of Daktronics Tuff Sport® Indoor Tennis LED Scoreboards. For additional information regarding the safety, installation, operation, or service of these displays, refer to the telephone numbers listed in **Section 5.8**. This manual is not specific to a particular installation.

Important Safeguards:

- Please read and understand all instructions before beginning the installation process.
- Do not drop control equipment or allow it to get wet.
- Do not disassemble control equipment or electronic controls of the display; failure to follow this safeguard will make the warranty null and void.
- Disconnect display power when not in use or when servicing.
- Disconnect display power before servicing power supplies to avoid electrical shock. Power supplies run on high voltage and may cause physical injury if touched while powered.
- Do not modify the scoreboard structure or attach any panels or coverings to the scoreboard without the express written consent of Daktronics, Inc.

Project-specific information takes precedence over any other general information found in this manual.

1.1 Scoreboard Controllers

Daktronics Tuff Sport tennis scoreboards are designed for use with the RC-100 handheld controller. Single-court scoreboards with optional Team Name Message Centers (TNMCs) require an All Sport® 5000 series control console, while multi-court models require a computer running DakTennis™ control software. All controllers use keyboard overlays (sport inserts) to control numerous sports and scoreboard models. Refer to the following manuals for operating instructions:

- **Remote Control System RC-100 Operational Overview (ED-15133)**
- **All Sport 5000 Series Control Console Operation Manual (ED-11976)**
- **DakTennis Version 3 Installation & Operation Manual (DD1965926)**

These control console manuals are available online at www.daktronics.com/manuals.

1.2 Scoreboard Label

Serial and model numbers of a Daktronics scoreboard can be found on the ID label on the display, similar to that shown in **Figure 1**.



Figure 1: Display ID Label

Please list the model number, display serial number, and the date this display became operational in the blanks provided on the second page of this manual. When calling Daktronics customer service, please have this information available to ensure the request is serviced as quickly as possible.

1.3 Model Number

Daktronics scoreboards are differentiated by their model numbers and two-letter prefixes for each sport. Most Daktronics scoreboards also carry a two-number suffix that refers to indoor-outdoor status, power supply, and digit color.

TN	Tennis
----	--------

-13	indoor scoreboards, 120 V, PanaView® digits
-14	indoor scoreboards, 230 V, PanaView® digits
-15	indoor scoreboards, 120 V, UniView® digits
-16	indoor scoreboards, 230 V, UniView® digits

1.4 Resources

Figure 2 illustrates a Daktronics drawing label. The drawing number is located in the lower-right corner of a drawing. This manual refers to drawings by listing the last set of digits and the letter preceding them. In the example, the drawing would be referred to as **Drawing C-325405**.

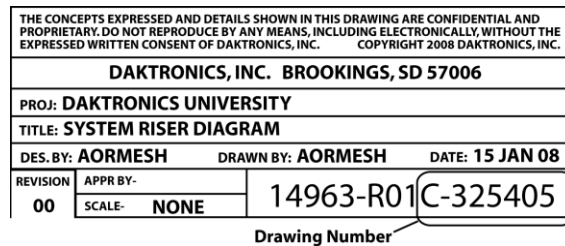

Figure 2: Daktronics Drawing Label

Reference Drawing:

System Riser Diagram.....**Drawing C-325405**

Daktronics identifies manuals by the DD or ED number located on the cover page of each manual. For example, this manual would be referred to as **ED-16309**.

1.5 Daktronics Nomenclature

Most components within this display carry a white label that lists the part number of the unit. If a component is not found in the Replacement Parts List in **Section 5.7**, use the label to order a replacement. **Figure 3** illustrates a typical label. The part number is in bold.

Main Component Labels	
Part Type	Part Number
Individual circuit board	0P-XXXX-XXXX
Assembly; a collection of circuit boards	0A-XXXX-XXXX
Wire or cable	W-XXXX
Fuse	F-XXXX
Transformer	T-XXXX
Metal part	M-XXX
Fabricated metal assembly	0S-XXXXXX
Specially ordered part	PR-XXXXX-X

Accessory Labels	
Component	Label
Termination block for power or signal cable	<u>TBXX</u>
Grounding point	<u>EXX</u>
Power or signal jack	<u>JXX</u>
Power or signal plug for the opposite jack	<u>PXX</u>

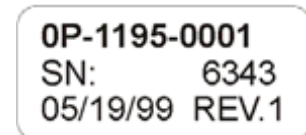

Figure 3: Typical Label

Following the Replacement Parts List is the Daktronics Exchange Policy and the Repair & Return Program. Refer to these instructions if replacing or repairing any display component.

1.6 Product Safety Approval

Daktronics Tuff Sport scoreboards are ETL-listed, tested to CSA standards and CE-labeled for indoor use. Contact Daktronics with any questions regarding the testing procedures.

Section 2: Specifications

The chart on the following pages details all of the mechanical specifications, circuit specifications, and power requirements for each display in this manual. Models are listed in alphanumeric order.

Note: All displays require a 120 VAC, 15 A circuit. Displays with a 230 VAC power requirement are also available.

Model & Options	Dimensions: Height, Width, Depth	Uncrated Weight	Watts	Amps 120 / 230 VAC	Driver # & Address
TN-2501	1'-6" H, 4'-0" W, 6" D (457 mm, 1219 mm, 152 mm)	25 lb (11 kg)	200 W	1.7 A / 0.9 A	A1: 11
TN-2503	3'-6" H, 8'-0" W, 6" D (1067 mm, 2438 mm, 152 mm)	112 lb (51 kg)	200 W	1.7 A / 0.9 A	A1: 11
w/ 0.75" TNMC	(same)	480 lb (218 kg)	300 W	2.5 A / 1.3 A	TNMC: 221
w/ 1.00" TNMC			400 W	3.3 A / 1.7 A	
TN-2504	3'-6" H, 9'-0" W, 6" D (1067 mm, 2743 mm, 152 mm)	126 lb (57 kg)	200 W	1.7 A / 0.9 A	A1: 11
w/ 0.75" TNMC	(same)	141 lb (64 kg)	300 W	2.5 A / 1.3 A	TNMC: 221
w/ 1.00" TNMC			400 W	3.3 A / 1.7 A	
TN-2505	2'-0" H, 9'-0" W, 6" D (610 mm, 2743 mm, 152 mm)	72 lb (33 kg)	200 W	1.7 A / 0.9 A	A1: 11
w/ 0.75" TNMC	(same)	87 lb (40 kg)	300 W	2.5 A / 1.3 A	TNMC: 221
w/ 1.00" TNMC			400 W	3.3 A / 1.7 A	
TN-2550	9'-0" H, 24'-0" W, 6" D (2743 mm, 7315 mm, 152 mm)	864 lb (392 kg)	1400 W	11.7 A / 6.1 A	A1-A6: 11-16 A7: 20
w/ 0.75" TNMC	(same)	969 lb (440 kg)	2100 W	17.5 A / 9.1 A	TNMC 1-6: 221-226
w/ 1.00" TNMC			2800 W	23.3 A / 12.2 A	TNMC 7: 230

Model & Options	Dimensions: Height, Width, Depth	Uncrated Weight	Watts	Amps 120 / 230 VAC	Driver # & Address
TN-2551	9'-0" D, 27'-0" W, 6" D (2743 mm, 8230 mm, 152 mm)	972 lb (441 kg)	1400 W	11.7 A / 6.1 A	A1-A6: 11-16 A7: 20
w/ 0.75" TNMC	(same)	1077 lb (489 kg)	2100 W	17.5 A / 9.1 A	TNMC 1-6: 221-226
w/ 1.00" TNMC			2800 W	23.3 A / 12.2 A	TNMC 7: 230
TN-2552	12'-6" H, 16'-0" W, 6" D (3810 mm, 4877 mm, 152 mm)	800 lb (363 kg)	1400 W	11.7 A / 6.1 A	A1-A6: 11-16 A7: 20
w/ 0.75" TNMC	(same)	905 lb (411 kg)	2100 W	17.5 A / 9.1 A	TNMC 1-6: 221-226
w/ 1.00" TNMC			2800 W	23.3 A / 12.2 A	TNMC 7: 230
TN-2553	12'-6" H, 18'-0" W, 6" D (3810 mm, 5486 mm, 152 mm)	900 lb (408 kg)	1400 W	11.7 A / 6.1 A	A1-A6: 11-16 A7: 20
w/ 0.75" TNMC	(same)	1005 lb (456 kg)	2100 W	17.5 A / 9.1 A	TNMC 1-6: 221-226
w/ 1.00" TNMC			2800 W	23.3 A / 12.2 A	TNMC 7: 230

Section 3: Mechanical Installation

Mechanical installation consists of lifting and permanently mounting the scoreboard or scoreboard sections. Be sure that the installation complies with local building codes.

Note: Daktronics does not assume any liability for any installation derived from the information provided in this manual or installations designed and installed by others.

3.1 Lifting the Scoreboard

Daktronics Tuff Sport tennis scoreboards are shipped equipped with eyebolts for lifting the displays, as well as pre-drilled holes along the top and bottom of each cabinet for wall attachment. Eyebolts are located along the top of the cabinet for each scoreboard or scoreboard section. Daktronics indoor scoreboards use $\frac{3}{8}$ " eyebolts.

Daktronics strongly recommends using a spreader bar, or lifting bar, to lift the display. Spreader bars ensure the force on the eyebolts remains straight up, minimizing lifting stress.

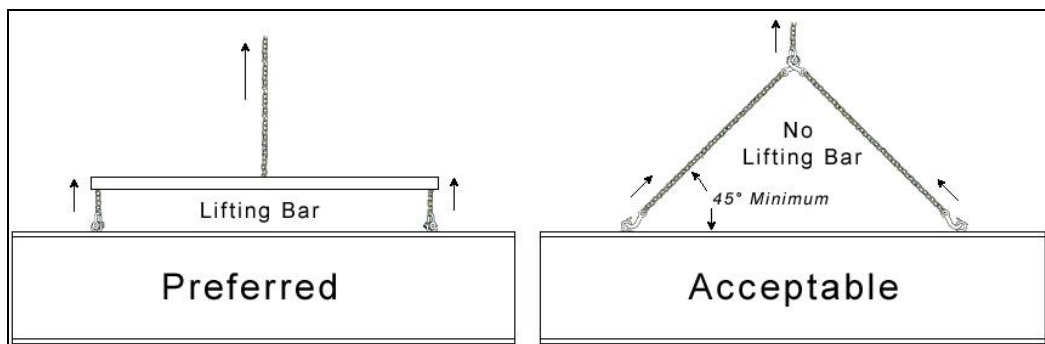

Figure 4: Lifting Methods

Figure 4 illustrates the preferred scoreboard lifting method on the left and an acceptable alternative lifting method on the right. When lifting the display:

- Use a spreader bar if possible.
- Use every lifting point provided.

Cables and chains attached to the eyebolts and directly to a center lifting point, as shown in the right-hand example in **Figure 4**, can create a dangerous lateral force on the eyebolts and may cause the eyebolts to fail. The smaller the angle between the cable and the top of the display, the lighter the sign must be to safely lift it. If this method must be used, ensure a minimum angle between the chain and scoreboard of at least 45°.

Do NOT attempt to lift the display if the angle is less than 45°.

Exceeding load angles or weight limits could cause the bolts in the scoreboard cabinet to buckle, resulting in serious damage to the scoreboard or injury to personnel. Also, loads should be applied directly in the plane of the eyebolt as shown in **Figure 5**.

Note: Daktronics assumes no liability for damages resulting from incorrect setup or lifting methods. Eyebolts are intended for lifting only. Do not attempt to permanently support the display by the eyebolts without the suspension mounting kit (see **Section 3.3**).

Small Daktronics scoreboards are not equipped with eyebolts, and instead use two lifting straps that encircle the scoreboard. It is recommended to use a spreader bar with the straps.

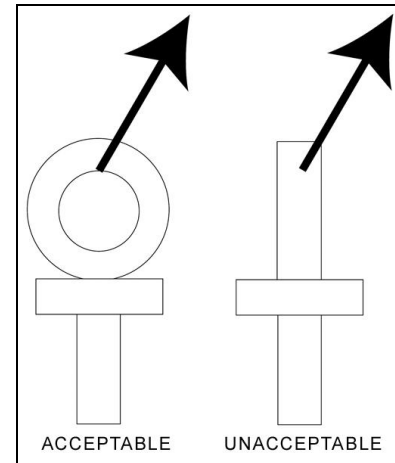

Figure 5: Eyebolt Plane Load

3.2 Scoreboard Mounting (Single- and Multi-Court Models)

1. Use the eyebolts at the top of the scoreboard frame to lift the display into position for mounting.
2. Secure the display to the wall by attaching mounting hardware through all holes on the top and bottom rear flanges of the display to a pre-drilled hole in the wall (**Figure 6**).

Note: For multi-court boards, mount the bottom scoreboard section first, remove the eyebolts, and mount the next section above it. Repeat until all sections are securely in place.

Due to the variety of wall materials used in sports facilities, Daktronics cannot anticipate a user's individual installation needs or provide mounting hardware suitable for every installation. Choose a method of installation that will safely support the weight of the display.

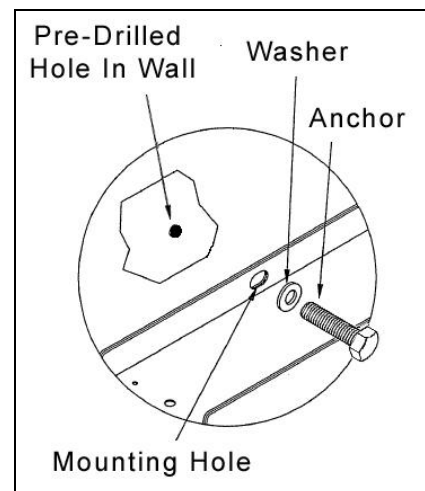

Figure 6: Wall Mounting

3.3 Suspension Mounting Kit (Single-Court Models Only)

One of several mounting options with the Tuff Sport scoreboards is a suspension lift eye installation, which requires a special mounting kit (part # 0A-1237-0016). Contact Daktronics about any installation that involves permanently suspending the scoreboard.

1. Secure the mounting angle with the $\frac{3}{8}$ " nut to each side of the scoreboard with the included screws. Install the eyebolts into the nut on the mounting angle.
2. Attach suspension cables to the eyebolt using a shackle and pin (all of this equipment is provided by others).

Notes:

- 1) Daktronics recommends that two cables be used at each end of the scoreboard.
- 2) Cables and hardware must be specified by a licensed engineer.
- 3) Do not attach suspension hardware to ad panels – attach to top of scoreboard.
- 4) This installation method must not be used to support scoreboard with message centers and/or backlit ad panels attached.
- 5) The total weight of scoreboard and accessories must not exceed 500 lb (223 kg).

Similar to the eyebolts used to lift the scoreboard, the suspension eyebolts have a maximum angle at which they can safely support the display. The ideal angle is perpendicular to the top of the scoreboard, but this angle may extend up to 30° out to either side of the display.

Refer to **Drawing A-148644** in **Appendix B** for more information.

3.4 Ad Panel Mounting

Refer to **Drawing A-147668** in **Appendix B** for typical ad panel mounting (similar to **Scoreboard Mounting** shown above) or **Drawing A-156134** for instructions on mounting ad panels to the top or bottom of a scoreboard.

3.5 Scoreboard Protective Devices

Daktronics Tuff Sport displays have been designed so that a normal tennis ball impact will not damage the LEDs or display cabinet, reducing the need for protective devices. Some users, however, may still wish to have additional protection from other projectiles, and in these cases, Daktronics provides optional protective devices. Refer to the **Protective Screen Installation Instructions (ED-5423)**, available online at www.daktronics.com/manuals for more information about installing protective devices.

Note: Scoreboard protection devices not provided by Daktronics must be approved by Daktronics prior to installation. Failure to follow this approval procedure will void the scoreboard warranty.

Section 4: Electrical Installation

CAUTION: Only qualified individuals should access the electrical components of the display and its associated equipment. It is the responsibility of the electrical contractor to ensure that all electrical work meets or exceeds local and national codes.

Daktronics engineering staff must approve all changes or the warranty will be void.

4.1 Installation Overview

The diagram shown in **Figure 7** illustrates a typical wireless setup between a single-court scoreboard and the control system. Daktronics part numbers are shown in parentheses. **Drawings A-177098** and **A-252412** in **Appendix D** also show power and signal layouts. Refer also to **Drawing A-227465** for wireless RC-100 base station installation. **Section 6.1** provides more information about the All Sport radio option.

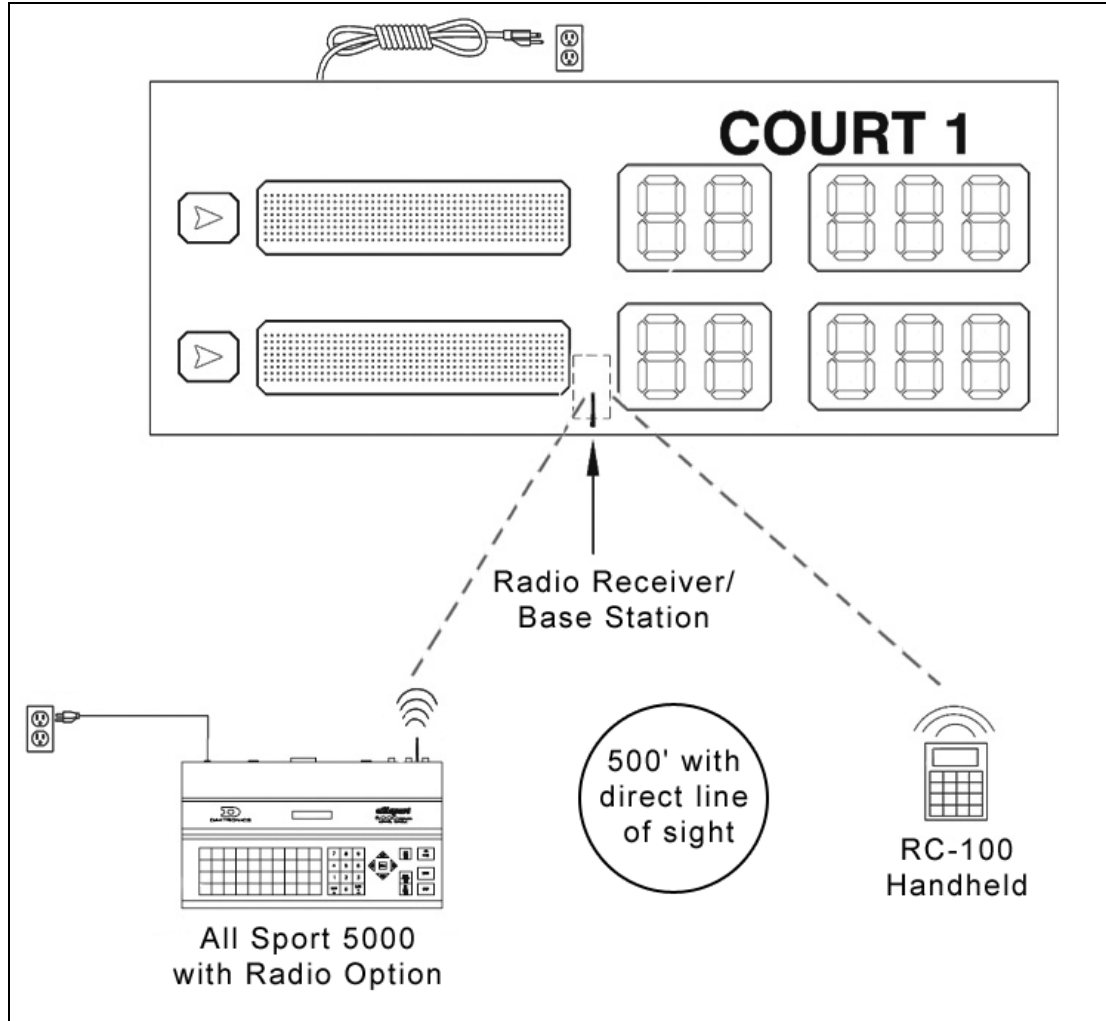

Figure 7: Wireless Single-Court Installation

The diagram shown in **Figure 8** illustrates a typical wired setup between a single-court scoreboard and the control system.

Note: Control signal cable and some junction boxes are not provided as part of this system and can be purchased locally or from Daktronics.

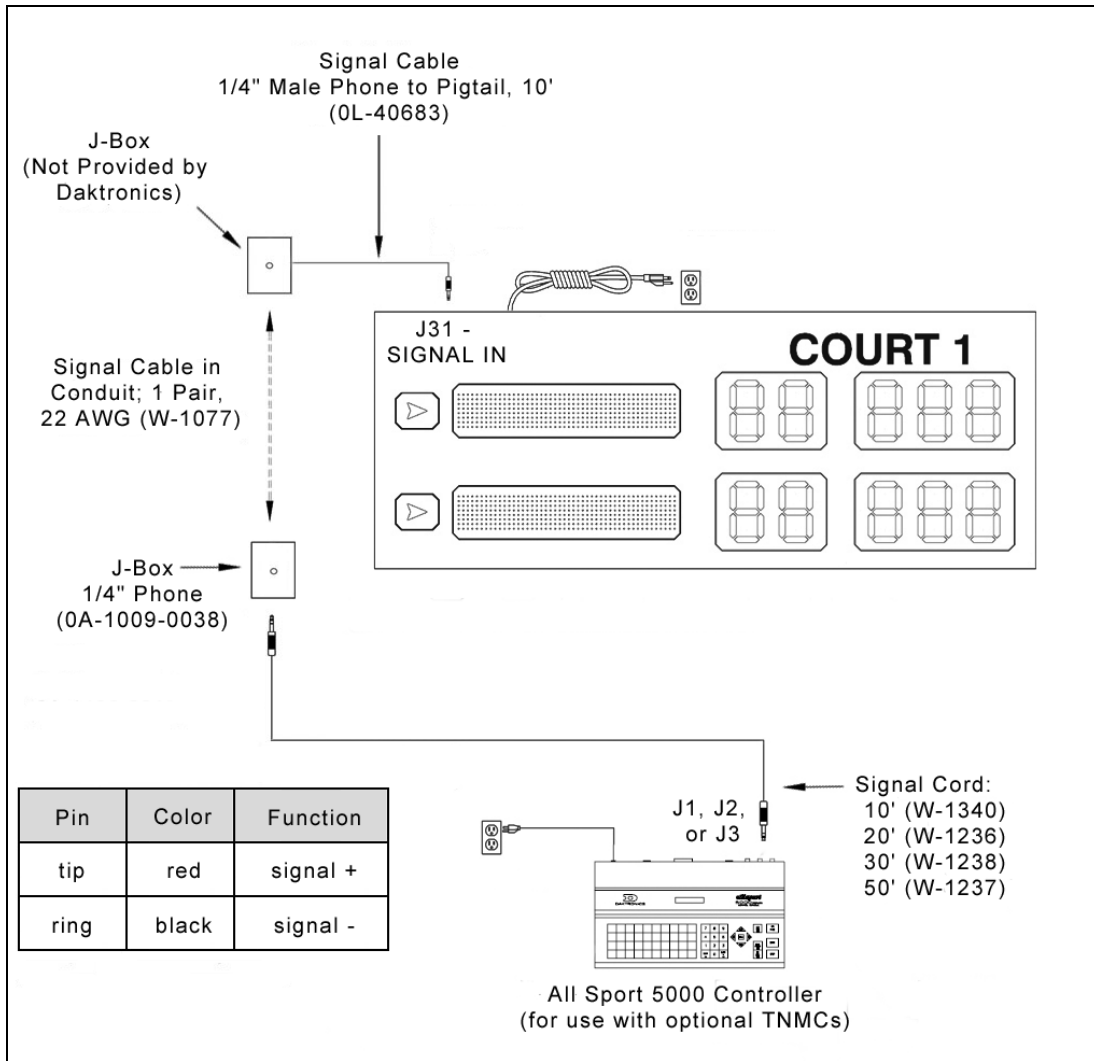

Figure 8: Wired Single-Court Installation

The diagram shown in **Figure 9** illustrates a typical setup between a multi-court scoreboard, optional single-court scoreboards, and a wireless or DakTennis™ control system. Daktronics part numbers are shown in parentheses. **Drawings B-231298** and **B-233254** in **Appendix D** also show power and signal layouts. Refer also to **Drawing A-227465** for wireless RC-100 base station installation.

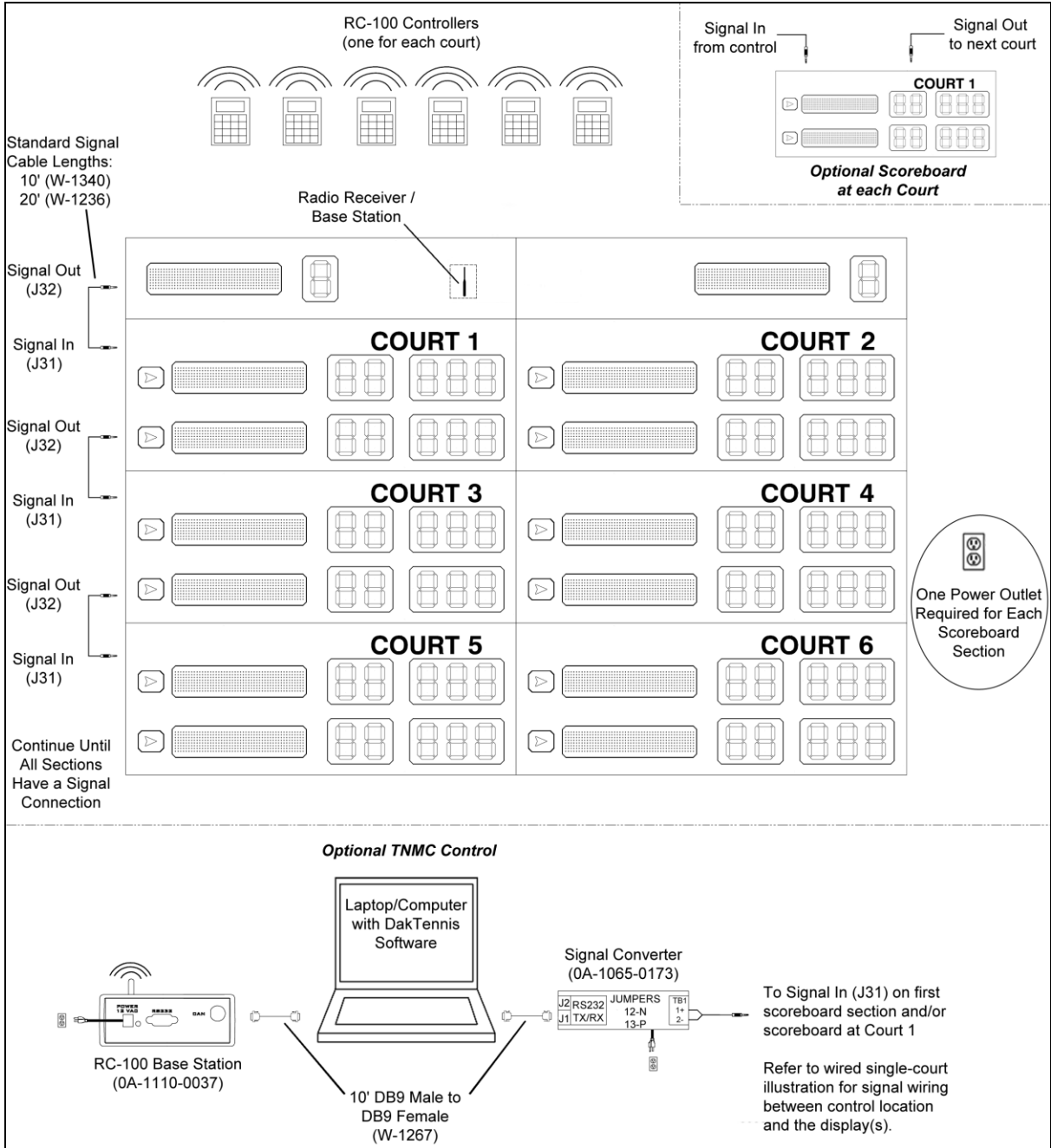

Figure 9: Multi-Court Installation

Note: When each court will also have its own scoreboard controlled by the DakTennis system, the scoreboards must be set to specific driver addresses. Refer to **Section 5.4** for more information about setting driver addresses and **Drawing A-1054354** in **Appendix D** for addressing information.

4.2 Power

Each scoreboard and scoreboard section features a 120 VAC power cord with a three-prong plug. Install a grounded receptacle near the equipment so that the power cord can easily reach it. The control console requires a 120 VAC receptacle and uses less than 1 A of power.

Displays operating on 230 VAC are also available, and they are shipped equipped with a universal power plug.

Grounding

Connect the scoreboard to earth ground. Proper grounding assures reliable equipment operation and protects the equipment against damaging electrical disturbances and lightning. Daktronics recommends a resistance-to-ground of 10 ohms or less. The electrical contractor performing the electrical installation can verify ground resistance. Daktronics Sales and Service personnel can also provide this service. The grounding connection on the power cord's three-prong plug connects to the shell of the scoreboard.

Note: The customer must properly ground the outlet according to local and national codes. Failure to ground the outlet voids the warranty for the scoreboard.

4.3 Power-On Self-Test (POST)

The scoreboard performs a self-test each time that power is turned on and the control console is powered off or not attached to the scoreboard. If the control console is attached and powered on, the self-test does not run, and data from the control console is displayed on the scoreboard after a brief period of time. Each scoreboard self-test pattern will vary depending on the scoreboard model, the number of drivers and types of digits. **Figure 10** shows an example of the LED bar test pattern that each digit performs.

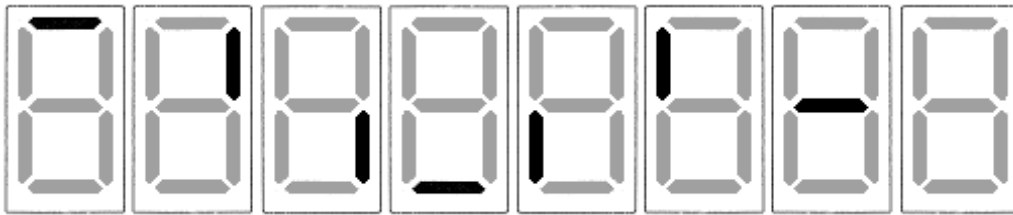

Figure 10: Digit Segment POST

Radio Settings

If an All Sport radio receiver is installed (see **Section 6.1**), the radio broadcast settings ("b1") and the channel settings ("C1") will be displayed in the game/set score digits (**Figure 11**) during the POST. These values must match the settings in the control console (refer to the appropriate control console manual listed in **Section 1.1**).



Figure 11: Radio Settings in Game/Set Digits

Note: Scoreboards using the RC-100 controller will only display the channel settings.

4.4 Single-Court Signal Connection

For single-court scoreboards using a wired All Sport 5000 setup, signal installation requires routing control cable from the scoreboard control console to a signal junction box (J-box) near the display. Refer to **Drawing A-28124** in **Appendix D** for signal wire connection.

1. At a minimum, use a paired, 22 AWG shielded cable (part # W-1077) and connect the cable to a 1/4" J-box at the control console end.
2. Route the cable from the J-box on the control console end to a J-box near the display.
3. Install the 1/4" phone plug (part # 0L-40683) to the display end of the cable. Be sure to connect the cable shielding only in the J-box on this end.

Note: DO NOT connect cable shielding at the J-box near the control console.

4. Insert the plug into the Signal In (J31) jack on the scoreboard.
5. Connect a signal cable from the J-box to the J1, J2, or J3 jack on the back of the All Sport 5000 console.

4.5 Multi-Court Scoreboard Signal Connection

- Connect a 1/4" phone plug cable between the Signal Out (J32) jack on the first scoreboard section to the Signal In (J31) jack on next scoreboard section. Repeat this process until all scoreboard sections are connected.

For multi-court scoreboards using team name message centers (TNMCs), signal installation also requires a wireless base station to receive the signal from the handheld RC-100 controllers, a computer running DakTennis™ software, and a signal converter to send the wired signal to the display. Refer to **Figure 9** and **Drawing B-231298** in **Appendix D**.

1. Plug in the wireless base station (part # 0A-1110-0037).
2. Connect a 9-pin serial cable (part # W-1267) between the RS232 jack of the wireless base station and an available COM port on a computer running the DakTennis software. Ensure the wireless base station is set to **Function "5"**.
3. Connect another 9-pin serial cable between the DakTennis computer and the J1 jack of a signal converter (part # 0A-1065-0173).

Note: If the DakTennis computer only has one COM port, it will be necessary to use a USB-to-Serial converter (not provided by Daktronics).

4. At a minimum, use a paired, 22 AWG shielded cable (part # W-1077) and connect the cable from the TB1 jack of the signal converter to a 1/4" J-box.
5. Route the cable from the J-box on the control end to a J-box near the display.
6. Install the 1/4" phone plug (part # 0L-40683) to the display end of the cable. Be sure to connect the cable shielding only in the J-box on this end.

Note: DO NOT connect cable shielding at the J-box near the control console.

7. Route the 1/4" phone plug from the J-box near the display to the scoreboard.
8. Insert the plug into the Signal In (J31) jack on the first scoreboard section, and connect signal cables between each section as described above.

Section 5: Scoreboard Troubleshooting

IMPORTANT NOTES:

1. Disconnect power before doing any repair work on the scoreboard.
2. Allow only qualified service personnel access to internal display electronics.
3. Disconnect power when not using the scoreboard.

5.1 Troubleshooting Table

The table below lists potential problems with the scoreboard and indicates possible causes and corrective actions. This list does not include every symptom that may be encountered, but it does present several of the most common situations that may occur.

Many of the solutions offered below provide references to other sections within this manual or to supplemental product manuals with further detail on how to fix the problem.

If a problem occurs that is not listed or that cannot be resolved using the solutions in the following table, contact Daktronics using the information provided in **Section 5.8**.

Problem	Possible Cause	Solution/Items to Check
Scoreboard doesn't light and console doesn't work	No power to the scoreboard	Check that the main circuit breaker for the scoreboard is on.
		Check that the scoreboard is receiving 120 (or 230) VAC power.
	No power to console	Ensure the console is plugged into a 120 (or 230) VAC power supply.
		Swap the console with one known to work correctly, and enter the proper sport code and/or radio settings to test. Replace console if necessary.
Scoreboard digits don't light, but console works	No wired signal from console	Check that the scoreboard is receiving 120 (or 230) VAC power.
		Check that the red DS2 LED on the driver lights up when sending commands from the control console (see Section 5.4).
	No radio signal from console	Cycle power to the scoreboard and watch for radio receiver broadcast/channel settings (see Section 4.3).
		Check that the green POWER and amber RADIO IN RANGE indicators on the radio receiver in the scoreboard light up when the control console is powered on. Keep the console between 20 to 500 feet from the scoreboard.

Problem	Possible Cause	Solution/Items to Check
		Move the console 20-30 feet from the scoreboard and test again. Verify that both the console and scoreboard antennae are securely tightened and in a vertical position.
		Replace the radio receiver.
	No signal to driver	Check that the scoreboard is receiving 120 (or 230) VAC power.
		Check that the red DS2 LED on the driver lights up when sending commands from the control console (see Section 5.4). Swap the driver with one known to work correctly and with the same part number to verify the problem. Replace if necessary (see Section 5.4).
No power to driver	Check that the green DS1 LED on the driver is always lit up when the scoreboard is powered on (see Section 5.4).	
Scoreboard digits light, but not in the correct order	Incorrect sport code	Ensure the correct sport code is being used for the scoreboard model. Refer to the control console operation manual (see Section 1.1).
	Incorrect driver address	Check that the scoreboard driver(s) are set to the correct address(es) (see Section 5.4).
Scoreboard digits light, console works, but no display on scoreboard	No wired signal from console	(See solution on previous page)
	No radio signal from console	(See solution on previous page)
	Bad/damaged wiring	Check that the red DS2 LED on the driver lights up when sending commands from the control console (see Section 5.4).
Scoreboard works, but some LEDs always stay on	Short in digit or indicator circuit	Swap the digit/indicator with one known to work correctly to verify the problem. Replace if necessary (see Section 5.3).
Scoreboard works, but some LEDs do not light or they blink	Bad connection	Verify the power/signal connector on the back of the digit circuit board is secure (see Section 5.3).
	Bad digit or driver	Swap the digit/driver with one known to work correctly to verify the problem. Replace if necessary (see Section 5.3 for digits or Section 5.4 for drivers).

Problem	Possible Cause	Solution/Items to Check
Scoreboard works, but some digits do not light	Bad digit or driver	(see solution on previous page)
	Incorrect sport code	(see solution on previous page)
	Incorrect driver address	(see solution on previous page)
	Wrong console controlling scoreboard	Another console's radio signal could be transmitting to the scoreboard.
	Radio interference	There may be other radio transmissions in the area that overpower the console. If it is not possible to disable the interfering device, It may be necessary to run a wired signal connection instead.
Scoreboard works, but a certain section of digits do not light	Bad multi-section connection	Verify signal cables between scoreboard sections properly connected (see Section 4.5)

5.2 Component Location & Access

All Tuff Sport indoor tennis scoreboards are front-access scoreboards, meaning that internal electronic components and digits are reached by opening a face panel, an access door, or a digit panel on the front of the display.

Digit panels are typically held in place on the scoreboard face by two screws. To remove a digit, simply unfasten the screws and carefully lift it from the cabinet. The power/signal plug can then be removed from the connector on the back of the digit to completely free the digit and access internal components.

Remove non-digit access panels by unfastening the top, side or bottom screws holding it in place. Some panels are hinged and swing open when the screws are removed or loosened.

Component location varies with each scoreboard model, but drivers and power and signal components are typically mounted inside the scoreboard behind a digit panel. To locate the driver(s), look for a warning label similar to that shown in **Figure 12**.

Refer to the component location drawings in **Appendix A** for model-specific component layouts and access locations.



Figure 12: Power Warning Label

5.3 Replacing Digits

LEDs are embedded in a circuit board that is mounted to the back of the digit panel. Do not attempt to remove individual LEDs. In the case of a malfunctioning LED or digit segment, replace the entire digit circuit board. The process of replacing digits varies by whether it is a PanaView digit or UniView digit (**Figure 13**).

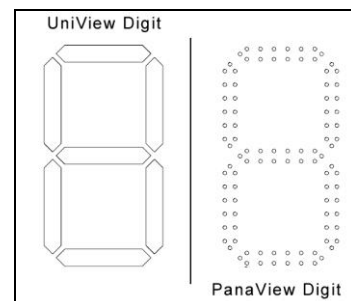

Figure 13: Digit Types

PanaView

To replace a PanaView digit circuit board (**Figure 14**):

1. Open the digit panel as described in **Section 5.2**.
2. Disconnect the power/signal connector from the back of the digit by squeezing together the locking tabs and pulling the connector free.
3. Use a $\frac{9}{32}$ " nut driver to remove the nuts securing the digits to the inside of the panel, and then lift the digit off the stud inserts.
4. Position a new digit over the studs (making sure the small plastic spacers are still in place) and tighten the nuts.
5. Reconnect the power/signal connector.

Note: This is a keyed connector and it will attach in one way only. Do not attempt to force the connection.

6. Secure the digit panel to the display with the two screws, then power up and test the display to see if changing the digit has resolved the problem.

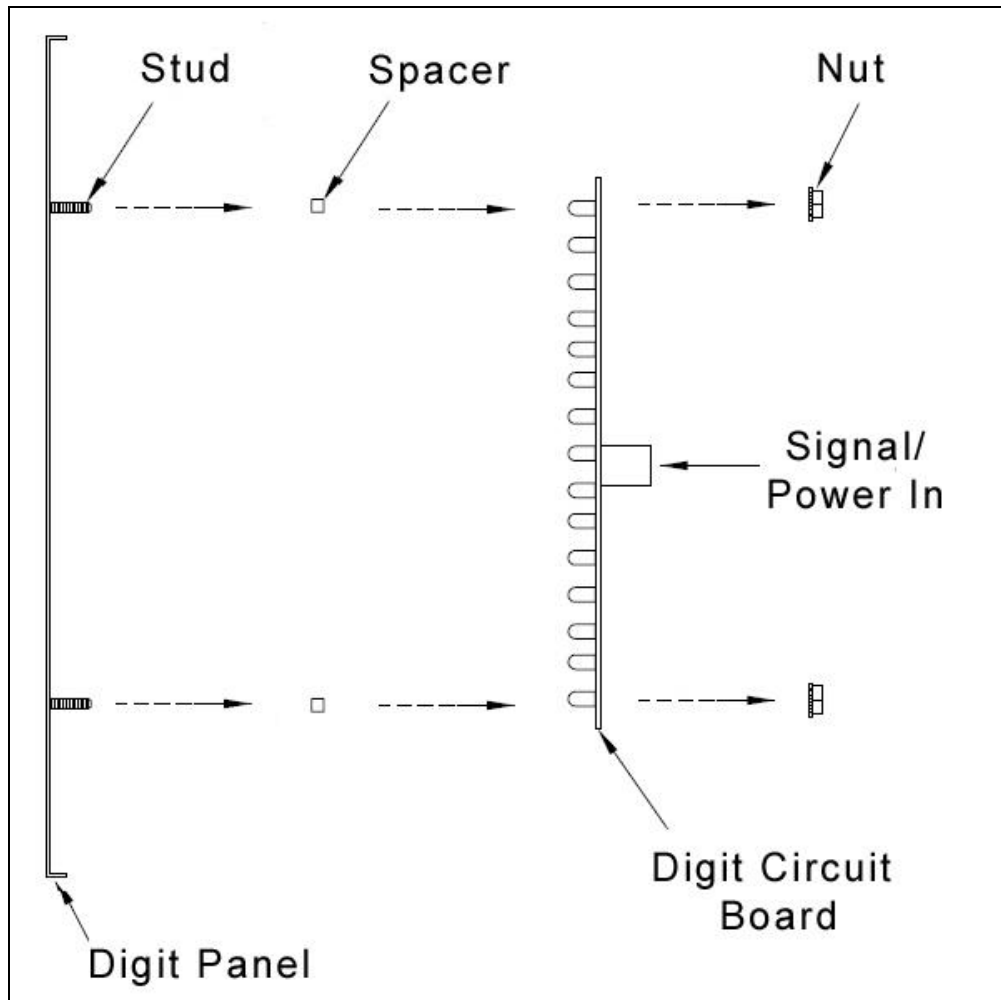

Figure 14: PanaView Digit Assembly

UniView

To replace a UniView digit circuit board (**Figure 15**):

1. Open the digit panel as described in **Section 5.2**.
2. Disconnect the power/signal connector from the back of the digit by squeezing together the locking tabs and pulling the connector free.
3. Use a $\frac{9}{32}$ " nut driver to remove the nuts securing the digits to the aluminum standoffs, and then lift the digit off the standoff/diffuser assembly.
4. Position a new digit over the standoffs, and tighten the nuts. It may be necessary to also tighten the standoffs if they became loose while removing the nuts.
5. Reconnect the power/signal connector.

Note: This is a keyed connector and it will attach in one way only. Do not attempt to force the connection.

6. Secure the digit panel to the display with the two screws, then power up and test the display to see if changing the digit has resolved the problem.

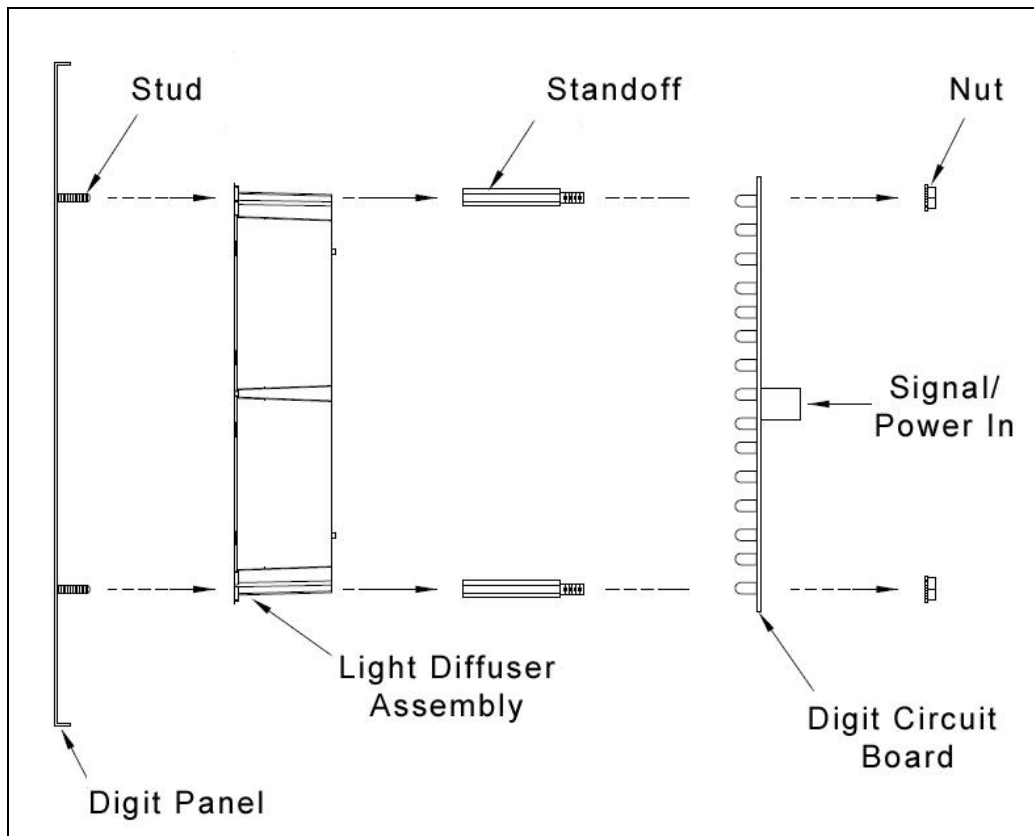

Figure 15: UniView Digit Assembly

5.4 LED Drivers

In each scoreboard, one or more LED drivers perform the task of switching LEDs on and off. LED drivers are located inside of a driver enclosure. Refer to **Figure 16** to view the location and components of a Tuff Sport driver enclosure.

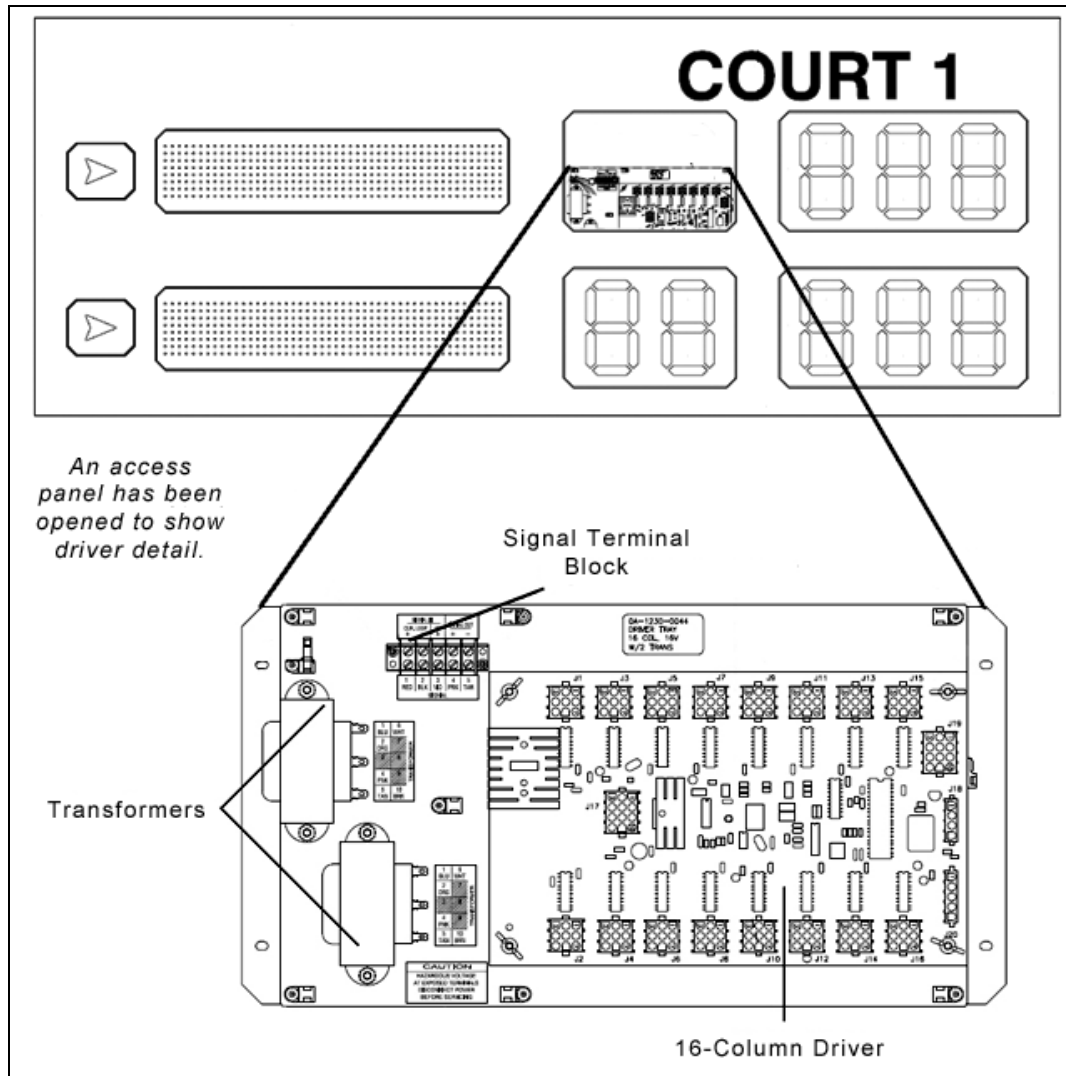

Figure 16: Driver Enclosure Location & Components

All Tuff Sport tennis scoreboards use 16-column drivers (**Figure 16**). Multi-court scoreboard models contain more than one driver to accommodate all of the digits and indicators. Refer to the component location drawings in **Appendix A** to determine the type and number of drivers for a particular scoreboard model.

Each driver has numerous connectors providing power and signal inputs and outputs to the scoreboard digits and indicators. The table on the following page shows the function of these connectors for a 16-column driver:

Connector #	Function
1-16	Output to digits and indicators
17	Control signal
19	Address

Refer to **Drawing A-126174** in **Appendix D** for detailed driver pin out/switch specifications.

When troubleshooting driver problems, three LEDs labeled **DS1**, **DS2**, and **DS3**, provide the following diagnostic information:

LED	Color	Function	Operation	Summary
DS1	Green	Power	Steady on	DS1 will be on and steady to indicate the driver has power.
DS2	Red	Signal RX	Steady on or blinking	DS2 will be on or blinking when the driver is receiving a signal and off when there is no signal.
DS3	Amber	Status	Blinking	DS3 will be blinking at one second intervals to indicate the driver is running.

Note: While it is necessary to have the scoreboard powered on to check the LED driver status indicators, always disconnect scoreboard power before servicing.

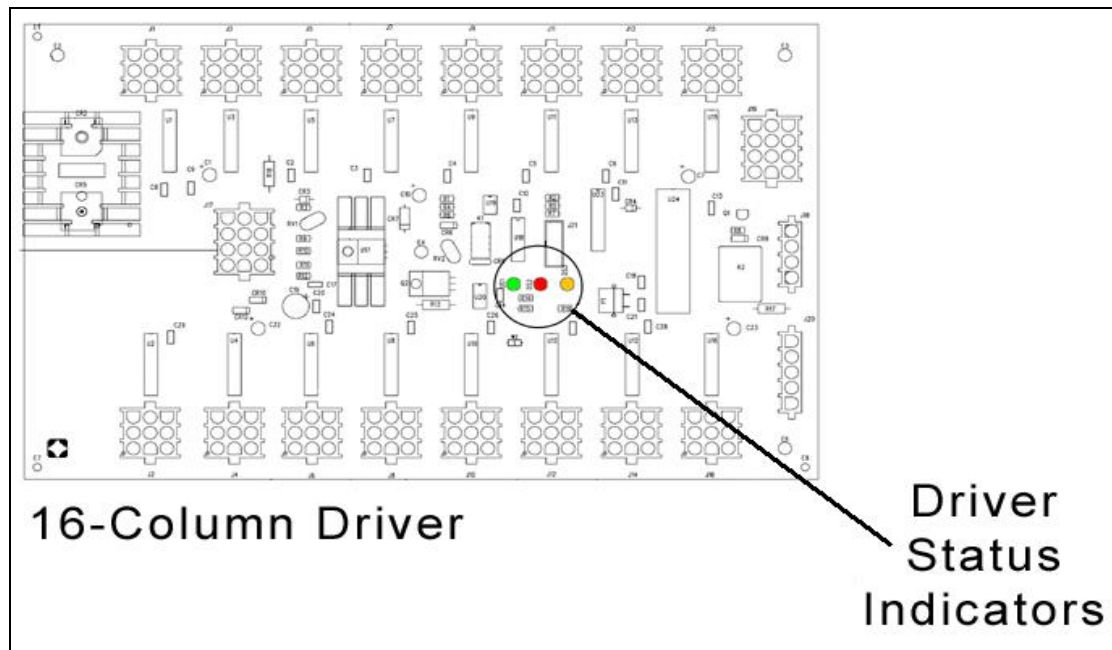

Figure 17: Driver Status Indicators

Replacing a Driver

If the driver status indicators do not appear to be working correctly, it may be necessary to replace the driver.

1. Open the digit panel or scoreboard face panel as described in **Section 5.2**.
2. Disconnect all connectors from the driver by squeezing together the locking tabs and pulling the connectors free.

Note: It may be helpful to label the cables to know which cable goes to which connector when reattaching the driver.

3. Remove the wing nuts securing the driver to the driver tray.
4. Carefully lift the driver from the display and place it on a clean, flat surface.
5. Position a new driver over the screws and tighten the nuts.
6. Reconnect all power/signal connectors.

Note: The connectors are keyed and will attach in one way only. Do not attempt to force the connections.

7. Ensure the driver is set to the correct address (refer to **Setting the Driver Address**).
8. Close and secure the access panel, then power up and test the scoreboard to see if changing the driver has resolved the problem.

Setting the Driver Address

Since the same LED drivers can be used for many scoreboard models, each driver must be set to receive the correct signal input, or address, for the model being used. This address is set with jumper wires in a 12-pin plug which mates with jack J19 on the driver (**Figure 18**).

It may be possible to reuse the same address plug from the driver that was replaced. If not, first refer to the specifications table in **Section 2** to find the correct driver address(es) for a particular scoreboard model. Then refer to **Drawing A-1054354** in **Appendix D** for a listing of the wire/pin connections for up to 12 courts, including TNMCs.

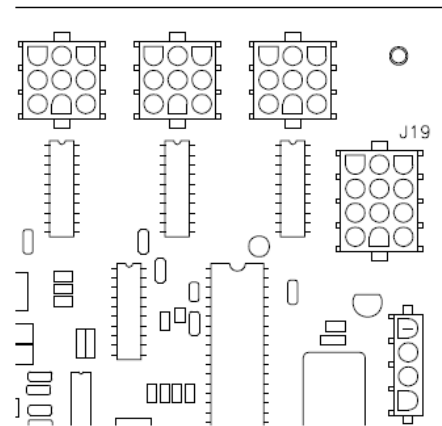

Figure 18: Address Jack J19

Multiple Drivers

Scoreboards that require multiple drivers operate using a master/slave driver configuration. Master and slave drivers function identically, but slave units lack the power/signal termination blocks. The drivers have been designed to simply plug into one another, and this is done at the factory, so no additional on-site connection is necessary.

If it appears as though only a certain group of digits on the scoreboard is not functioning, there may be a problem with the slave driver(s) or the power/signal connection from the other driver(s).

5.5 Segmentation and Digit Designation

In each digit, certain LEDs always go on and off together. These groupings of LEDs are called segments. **Drawing A-38532** in **Appendix D** details which connector pin is wired to each digit segment and the wiring color code used throughout the display.

The component location drawings in **Appendix A** specify the driver connectors controlling the digits. Numbers shown in hexagons in the upper half of each digit indicate which connector is wired to that digit.

5.6 Schematics

For advanced scoreboard troubleshooting and repair, it may be necessary to consult the schematic drawings. Located in **Appendix C**, schematic drawings show detailed power and signal wiring diagrams of internal display components such as drivers and transformers as well as optional components like TNMCs and radio receivers.

5.7 Replacement Parts List

Refer to the following table for Daktronics scoreboard replacement parts.

Description	Daktronics Part #
Junction box; phone jack	0A-1009-0038
Signal Converter, 120 V	0A-1065-0173
RC-100 Handheld Controller	0A-1110-0053
RC-100 Base Station, Scoreboard Receiver	0A-1110-0035
RC-100 Base Station, Serial COM	0A-1110-0037
LED driver, 16-column	0P-1150-0126
PanaView Digit, 5" red LED, 7-seg	0P-1150-0200
PanaView Digit, 5" amber LED, 7-seg	0P-1150-0081
PanaView Digit, 10" red LED, 7-seg	0P-1230-0050
PanaView Digit, 10" amber LED, 7-seg	0P-1230-0051
PanaView Digit, 13" red LED, 7-seg	0P-1230-0052
PanaView Digit, 13" amber LED, 7-seg	0P-1230-0053
PanaView Arrow, Red, 3"	0P-1150-0185
PanaView Arrow, Amber, 3"	0P-1150-0164
PanaView Colon, Red	0P-1230-0070
PanaView Colon, Amber	0P-1230-0071
UniView Digit, 10" Red LED, 7-seg	0P-1230-0025
UniView Digit, 10" Amber LED, 7-seg	0P-1230-0026
UniView Digit, 13" Red LED, 7-seg	0P-1230-0027
UniView Digit, 13" Amber LED, 7-seg	0P-1230-0028
UniView 1 Position Indicator, Red	0P-1230-0037
UniView 1 Position Indicator, Amber	0P-1230-0039

Description	Daktronics Part #
UniView Colon, Red	0P-1230-0068
UniView Colon, Amber	0P-1230-0069
Transformer, 120P/16S, 6.3 A	T-1066
Cable, 20' phone plug	W-1236
Cable, 50' phone plug	W-1237
Cable, 30' phone plug	W-1238
Cable, 10' phone plug	W-1340

5.8 Daktronics Exchange and Repair & Return Programs

Exchange Program

The Daktronics Exchange Program is a service for quickly replacing key components in need of repair. If a component fails, Daktronics sends a replacement part to the customer who, in turn, returns the failed component to Daktronics. This decreases equipment downtime. Customers who follow the program guidelines explained below will receive this service.

Before Contacting Daktronics

Identify these important numbers:

Display Serial Number: _____
 Display Model Number: _____
 Job/Contract Number: _____
 Date Installed: _____
 Daktronics Customer ID Number: _____

To participate in the Exchange Program, follow these steps.

1. Call Daktronics Customer Service.

Market Description	Customer Service Number
Schools (including community/junior colleges), religious organizations, municipal clubs and community centers	877-605-1115
Universities and professional sporting events, live events for auditoriums and arenas	866-343-6018

2. When the new exchange part is received, mail the old part to Daktronics.

If the replacement part fixes the problem, send in the problem part being replaced.

- a. Package the old part in the same shipping materials in which the replacement part arrived.
- b. Fill out and attach the enclosed UPS shipping document.
- c. Ship the part to Daktronics.

3. **The defective or unused parts must be returned to Daktronics within 5 weeks of initial order shipment.**

If any part is not returned within five (5) weeks, a non-refundable invoice will be presented to the customer for the costs of replenishing the exchange parts inventory with a new part.

Daktronics reserves the right to refuse parts that have been damaged due to acts of nature or causes other than normal wear and tear.

Repair & Return Program

For items not subject to exchange, Daktronics offers a Repair & Return Program. To send a part for repair, follow these steps:

1. **Call or fax Daktronics Customer Service:**
Refer to the appropriate market number in the chart listed on the previous page.
Fax: **605-697-4444**
2. **Receive a case number before shipping.**
This expedites repair of the part.
3. **Package and pad the item carefully to prevent damage during shipment.**
Electronic components, such as printed circuit boards, should be placed in an antistatic bag before boxing. Daktronics does not recommend using packing 'peanuts' when shipping.
4. **Enclose:**
 - name
 - address
 - phone number
 - the case number
 - a clear description of symptoms

Shipping Address

Daktronics Customer Service
[Case #]
201 Daktronics Drive, Dock E
Brookings, SD 57006

Daktronics Warranty and Limitation of Liability

The Daktronics Warranty and Limitation of Liability is located in **Appendix E**. The Warranty is independent of Extended Service agreements and is the authority in matters of service, repair, and display operation.

Section 6: Scoreboard Options

6.1 Radio Control

All Sport radio control is an option for single-court tennis scoreboards. The system provides scoreboard control via a 2.4 GHz, extra-high frequency FM signal.

The radio transmitter and receiver are not standard equipment. This setup requires a control console equipped with a radio transmitter as well as a radio receiver plugged into the driver/power enclosure and mounted internally to the front panel of the scoreboard.

For additional information about this option, contact a Daktronics representative; for complete information on setting up radio communication control, refer to the **Gen V Radio Installation Manual (ED-13831)** or the **Gen VI Radio Installation Manual (DD2362277)**, both available online at www.daktronics.com/manuals.

6.2 Team Name Message Centers

Refer to **Section 7** for more information about Team Name Message Centers.

Section 7: TNMC Troubleshooting & Maintenance

IMPORTANT NOTES:

1. Always disconnect scoreboard power before doing any repair/maintenance work on the message centers.
2. Permit only qualified service personnel to access internal display electronics.
3. Disconnect power when not using the scoreboard.

7.1 Display Overview

Team Name Message Centers (TNMCs) are programmable LED displays that allow users to show custom Home and Guest names or messages of ~15 characters on the scoreboard in place of static vinyl captions. TNMCs are typically ordered factory-installed, but they may also be field-mounted after the scoreboard is in place. Characters are shown on one line using single- or double-stroke fonts.

Primary matrix sizes include 8x32 with 1" pixel spacing and 8x48 with 0.75" pixel spacing. **Figure 19** shows an example of 8x48, 0.75" TNMCs.

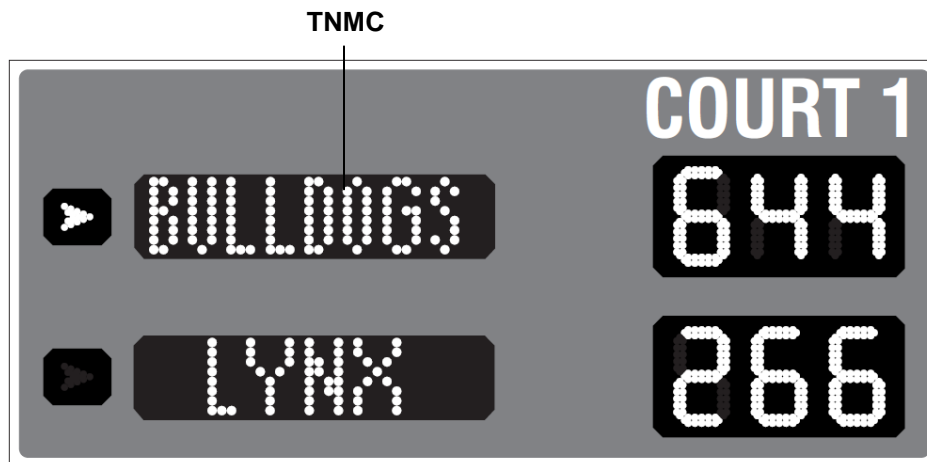

Figure 19: Tennis Scoreboard with TNMCs

Matrix Size	Number of Modules	Pixel Spacing	Active Display Area	Weight*
8x48	3	19 mm (0.75")	6" x 36" (152 mm x 914 mm)	15 lb (7 kg)
8x32	2	25 mm (1")	8" x 32" (203 mm x 813 mm)	20 lb (9 kg)

* Weight shown is for a pair of displays.

7.2 Initialization Information at Startup

Every time the display is powered up and there is no All Sport® signal present, the display will run through an initialization process, during which it will test all LEDs and addresses. First, the message center will display the proper address number.

If the entire display fails at startup, power may not be properly connected, or the address setting may not be correct on the display driver. Check both in the event of a failure.

7.3 Display Troubleshooting Table

The table below lists potential problems with the display and indicates possible causes and corrective actions. This list does not include every symptom that may be encountered, but it does present several of the most common situations that may occur.

Many of the solutions offered below provide references to other sections within this manual with further detail on how to fix the problem.

If a problem occurs that is not listed or that cannot be resolved using the solutions in the following table, contact Daktronics using the information provided in **Section 5**.

Symptom/Condition	Possible Remedy
One or more LEDs on a single module fails to light	Check/replace the ribbon cables on the module.
	Replace the module (see Section 7.7).
One or more LEDs on a single module fails to turn off	Check/replace the ribbon cables on module.
	Replace the module (see Section 7.7).
A section of the display not working; section extends all the way to the right side of the display	Check/replace the ribbon cables running to the first module that is not working.
	Replace the first module on the left side of the first module that is not working (see Section 7.7).
	Replace the second module that is not working (see Section 7.7).
	Replace the power supply assembly on the first module that is not working (see Section 7.8).
One row of modules does not work or is garbled	Replace the first module (see Section 7.7).
	Replace the display driver (see Section 7.6).
A group of modules that share the same power supply assembly fails to work	Replace the power supply assembly (see Section 7.8).
Entire display fails to work	Check for proper line voltage into the power termination panel.
	Check/replace the ribbon cable from the display driver to the modules.
	Check the voltage settings on the power supplies.
	Check/replace the signal cable to the driver.
	Repair/replace the driver (see Section 7.6).

7.4 Power & Signal Summary

Reference Drawings:

Schematic: 3/4" and 1" DC TNMC's **Drawing B-146975**

Refer to **Drawing B-146975** in **Appendix C** for detailed schematics about display power and signal routing.

Display signal routing can be summarized as follows:

1. Data from the All Sport® controller or DakTennis™ software travels via signal cable (or All Sport radio) into the scoreboard.
2. The signal then travels through the driver, typically re-driven from the driver TB-31 to the current loop interface (CLI) cards located on the right-hand module of each display.
3. A ribbon cable harness carries the signal to the first LED module, and the signal relays from module to module via ribbon cable in daisy-chain style until it reaches the last module in the display.

Display power routing can be summarized as follows:

1. Incoming power from the power cord terminates at the main scoreboard LED driver tray.
2. Using interconnect harnesses, the power is passed from the driver tray to the Home display power supply, and then to the Guest display power supply.
3. Power from the power supplies is relayed to all display modules.
4. The modules draw their power directly from the power supply assemblies; the display driver receives power out from the first module via ribbon cable.

7.5 Component Locations & Access

Reference Drawings:

Installation, 6" 8x48 & 8" 8x32 TNMC **Drawing B-261916**

To access the internal components of the display, simply remove the two screws on either side of the face panel that secure it to the scoreboard. Carefully remove the face panel from the scoreboard, as there will be several cables connected to it.

Drawing B-261916 in **Appendix B** provides a detailed view of each display component and the connections between them.

7.6 Display Drivers

Reference Drawings:

Address Details; Indoor Tennis Scoreboards **Drawing A-1054354**

Display drivers, also known as controllers or shift cards, use a 12-pin plug that mates with jack J4 to set the address. Refer to **Drawing A-1054354** in **Appendix D** for addressing information of tennis systems with up to 12 courts.

Figure 20 illustrates some of the primary jacks and indicators of a display driver.

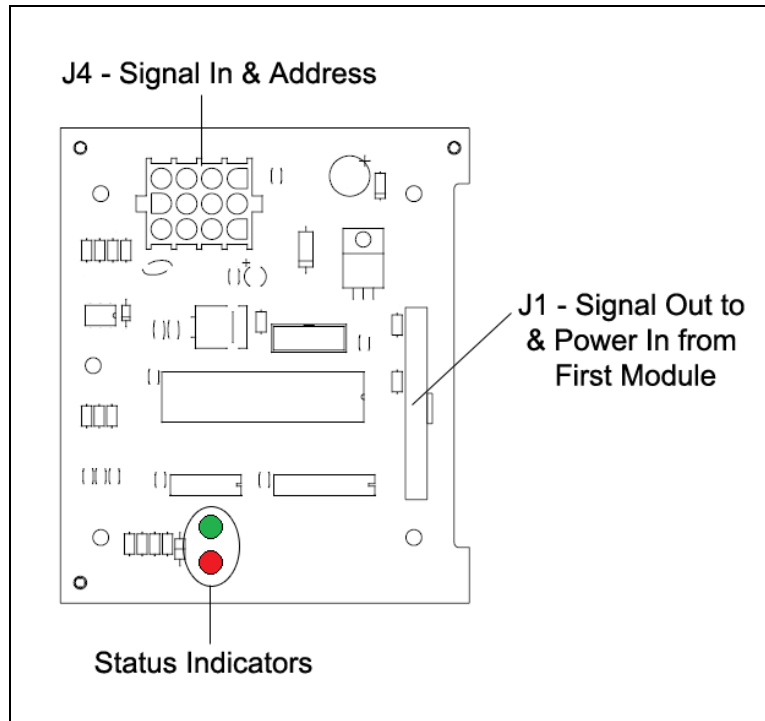

Figure 20: Display Driver

Diagnostic LEDs

The following table explains the functions of the primary diagnostic LEDs on the drivers:

LED Name	Color	Illumination Summary
DS1 PWR	Green	Steady on or blinking when the driver has power
DS2 RX	Red	Steady on or blinking when the driver is receiving and off when there is no current loop (CL) signal

Replacing a Driver

1. Access the internal components as described in **Section 7.5**.
2. Disconnect all power and signal connectors from the driver by squeezing together the locking tabs and pulling the connectors free.

Note: It may be helpful to label the cables to know which cable goes to which connector when reattaching a driver.

3. Remove the four screws securing the driver to the module. This will be the right-most module, when viewing the display from the front.
4. Position a new driver over the standoffs on the module and tighten the screws.
5. Reconnect all power/signal connectors.
6. Power up and test the scoreboard/display to see if the problem has been resolved.

Refer to **Figure 21** for an overview of driver (and module) replacement.

7.7 Modules

Display modules consist of LEDs embedded in a circuit board. One or more circuit boards are mounted to the back of a display face panel. Do not attempt to remove individual LEDs. In the case of malfunctioning LEDs, replace the entire module circuit board.

Replacing Modules

1. Access the internal components as described in **Section 7.5**.
2. Carefully disconnect all ribbon cables from the driver by squeezing together the locking tabs and pulling the connectors free.

Note: It may be helpful to label the cables to know which cable goes to which connector when reattaching.

3. Remove the nuts securing the module circuit board to the face panel. If a display driver is attached to the module, remove it along with the screws and standoffs.
4. Position a new module on the front of the face panel and reconnect all ribbon cables.
5. Reattach the module to the face panel. If a display driver was previously removed from the module, reattach it at this time too.
6. Power up and test the scoreboard/display to see if the problem has been resolved.

Refer to **Figure 21** for an overview of module (and driver) replacement.

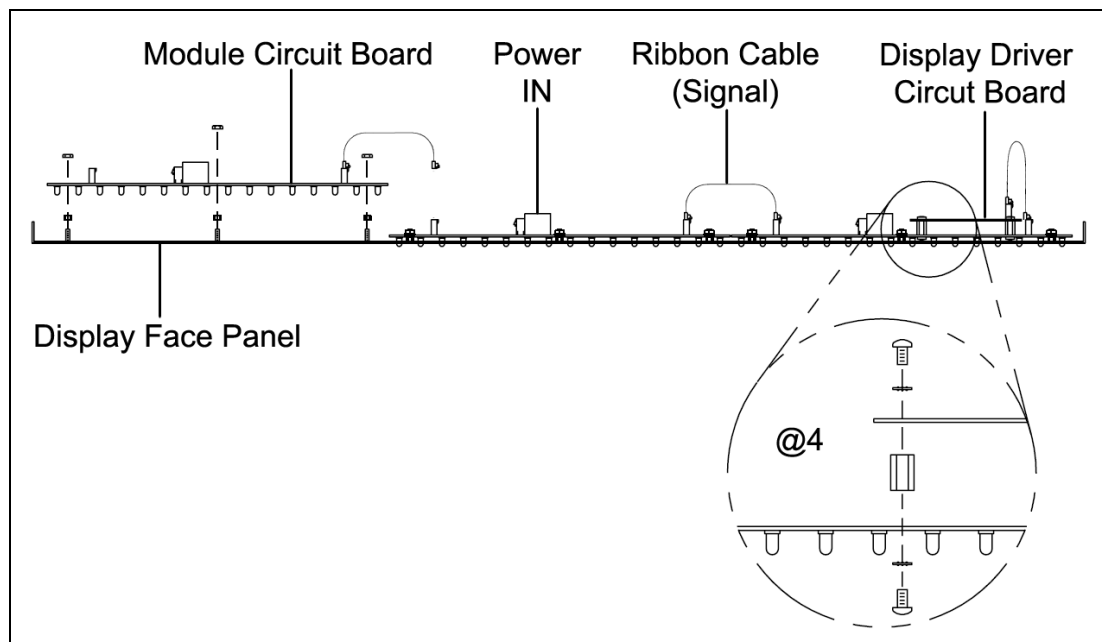

Figure 21: Replacing a Module or Driver, Top View (0.75" Mods Shown)

7.8 Power Supplies

Replacing a Power Supply

1. Access the internal components as described in **Section 7.5**.
2. Remove the two screws securing the power supply bracket, and remove it from the display cabinet.
3. Disconnect all the wires connected to the power supply.

Note: It may be helpful to label the cables to know which cable goes to which connector when reattaching.

4. Remove the three screws securing the power supply to the bracket, and attach the new power supply to it.
5. Reconnect all wires, and mount the power supply bracket inside the display cabinet.

7.9 Display Maintenance

Complete a yearly inspection to maintain safe and dependable display operation. This inspection should address the following issues:

- **Loose Hardware:** Verify that fasteners, such as bolts and rivets, have not come loose. Check and tighten or replace fasteners as required.
- **Excessive Dust Buildup:** It may be necessary to occasionally vacuum the inside of the display cabinet to remove dust/dirt buildup that may interfere with airflow.
- **Corrosion:** Check the paint, and look for possible corrosion

Note: If any of the preceding conditions are discovered, make the necessary repairs or take corrective action immediately.

7.10 Replacement Parts List

The following table contains display components that may have to be replaced. Many of the components within the display itself have attached part number labels.

Part Description	Part Number
Indoor TNMC Card	0P-1150-0206
Module; 8x16, Amber (1")	0P-1186-0104
Module; 8x16, Red (1")	0P-1186-0111
Module; 8x16, Amber (0.75")	0P-1186-0112
Module; 8x16, Red (0.75")	0P-1186-0204
Power Supply; 12V @ 8.5A, 85-264VAC (for 1" mods)	A-1555
Power Supply; 5V @ 10A, 85-264VAC (for 0.75" mods)	A-1568
Cable; 18 pos, Ribbon, 6"	W-1320

See **Section 5** for information on Daktronics Exchange and Repair and Return program.

Appendix A: Component Location Drawings

<i>Drawing Title</i>	<i>Drawing Number</i>
Component Location; TN-2501, Indoor Tennis	A-775555
Component Location; TN-2504, Indoor Tennis	A-775579
Component Location; TN-2551, Indoor Tennis	A-775742
Component Location; TN-2553, Indoor Tennis	A-776414
Component Location; TN-2550, Indoor Tennis	A-776724

TN-2501-13/-15

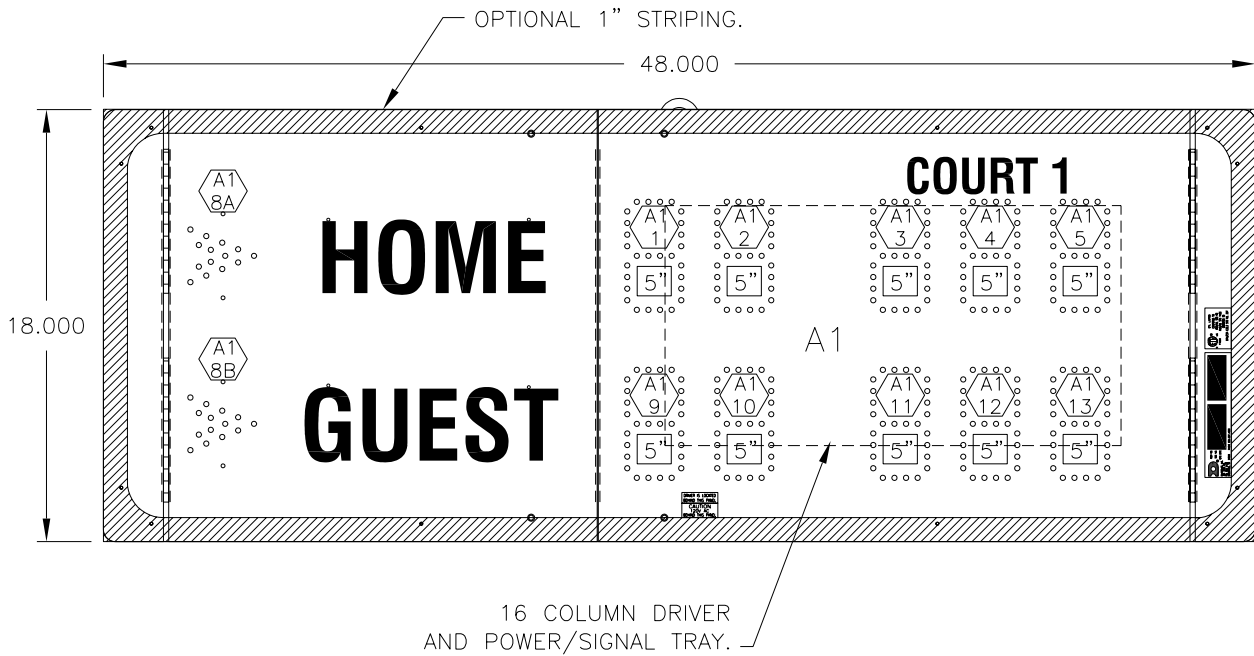

FRONT VIEW

NOTES:

1. LIFTEYE IS FOR TEMPORARY USE FOR LIFTING THE SCOREBOARD DURING INSTALLATION. DO NOT USE FOR PERMANENT INSTALLATION.
2. THE SCOREBOARD IS SHOWN WITH PANAVIEW DIGIT TECHNOLOGY. SEE DRAWING A-158550 FOR MORE DETAILS.

= LED DRIVER NUMBER & LED DRIVER CONNECTOR WIRED TO THAT DIGIT

= DIGIT SIZE

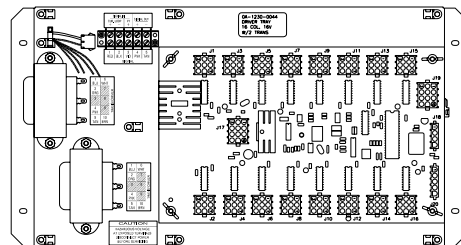

DRIVER DETAIL

THE CONCEPTS EXPRESSED AND DETAILS SHOWN ON THIS DRAWING ARE CONFIDENTIAL AND PROPRIETARY. DO NOT REPRODUCE BY ANY MEANS, INCLUDING ELECTRONICALLY WITHOUT THE EXPRESSED WRITTEN CONSENT OF DAKTRONICS, INC. COPYRIGHT 2008 DAKTRONICS, INC.

DAKTRONICS, INC. BROOKINGS, SD 57006

PROJ: TENNIS SCOREBOARDS

TITLE: COMPONENT LOCATION; TN-2501, INDOOR TENNIS

DES. BY: KDRAGT

DRAWN BY: KDRAGT

DATE: 10 DEC 08

REVISION

APPR. BY:

00

SCALE: 1=8

1164-R03A-775555

REV.	DATE	DESCRIPTION	BY	APPR.

TN-2504-13/-15

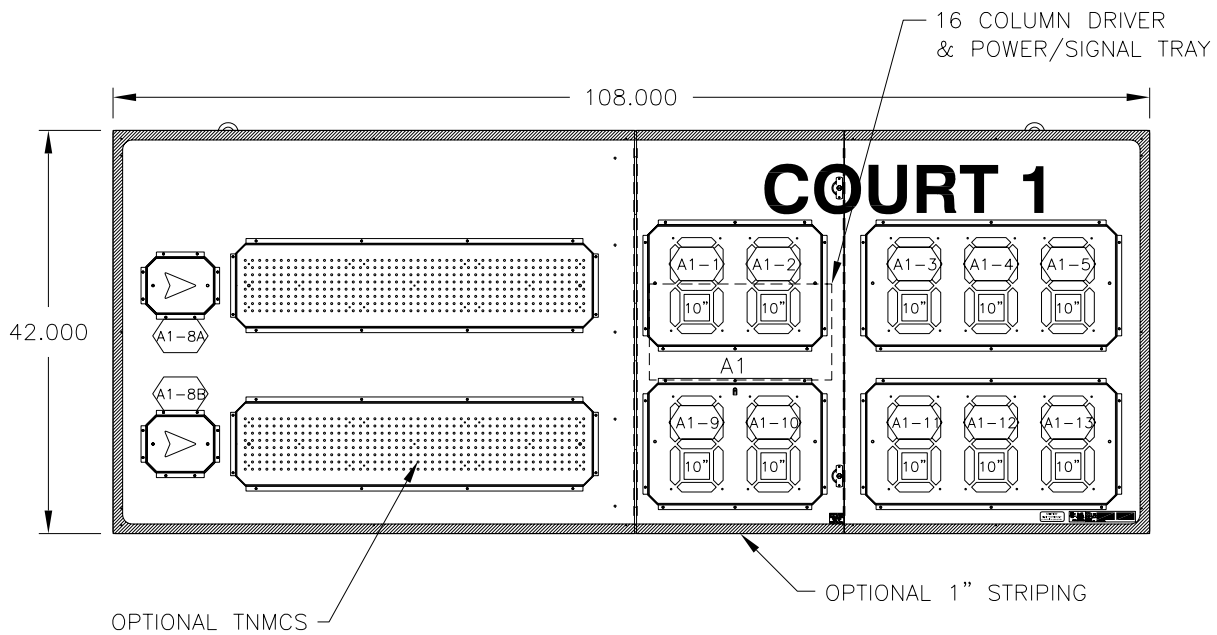

FRONT VIEW

NOTES:

1. LIFTEYE IS FOR TEMPORARY USE FOR LIFTING THE SCOREBOARD DURING INSTALLATION. DO NOT USE FOR PERMANENT INSTALLATION.
2. THE SCOREBOARD IS SHOWN WITH UNIVIEW DIGIT TECHNOLOGY. SEE DRAWING A-158550 FOR MORE DETAILS.

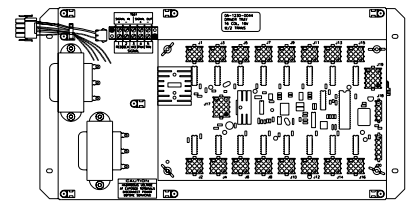

DRIVER DETAIL

SCALE X2

= LED DRIVER NUMBER & LED DRIVER CONNECTOR WIRED TO THAT DIGIT

= DIGIT SIZE

THE CONCEPTS EXPRESSED AND DETAILS SHOWN ON THIS DRAWING ARE CONFIDENTIAL AND PROPRIETARY. DO NOT REPRODUCE BY ANY MEANS, INCLUDING ELECTRONICALLY WITHOUT THE EXPRESSED WRITTEN CONSENT OF DAKTRONICS, INC. COPYRIGHT 2008 DAKTRONICS, INC.			
DAKTRONICS, INC. BROOKINGS, SD 57006			
PROJ: TENNIS SCOREBOARDS			
TITLE: COMPONENT LOCATION; TN-2504, INDOOR TENNIS			
DES. BY: KDRAGT		DRAWN BY: KDRAGT	DATE: 10 DEC 08
REVISION	APPR. BY:	1164-R03A-775579	
00	SCALE: 1=20		

REV.	DATE	DESCRIPTION	BY	APPR.

REV.	DATE	DESCRIPTION	BY	APPR.
------	------	-------------	----	-------

TN-2551-13/-15

16 COLUMN DRIVER & POWER/SIGNAL TRAY @7

OPTIONAL TIME OF DAY DIGIT PANEL.

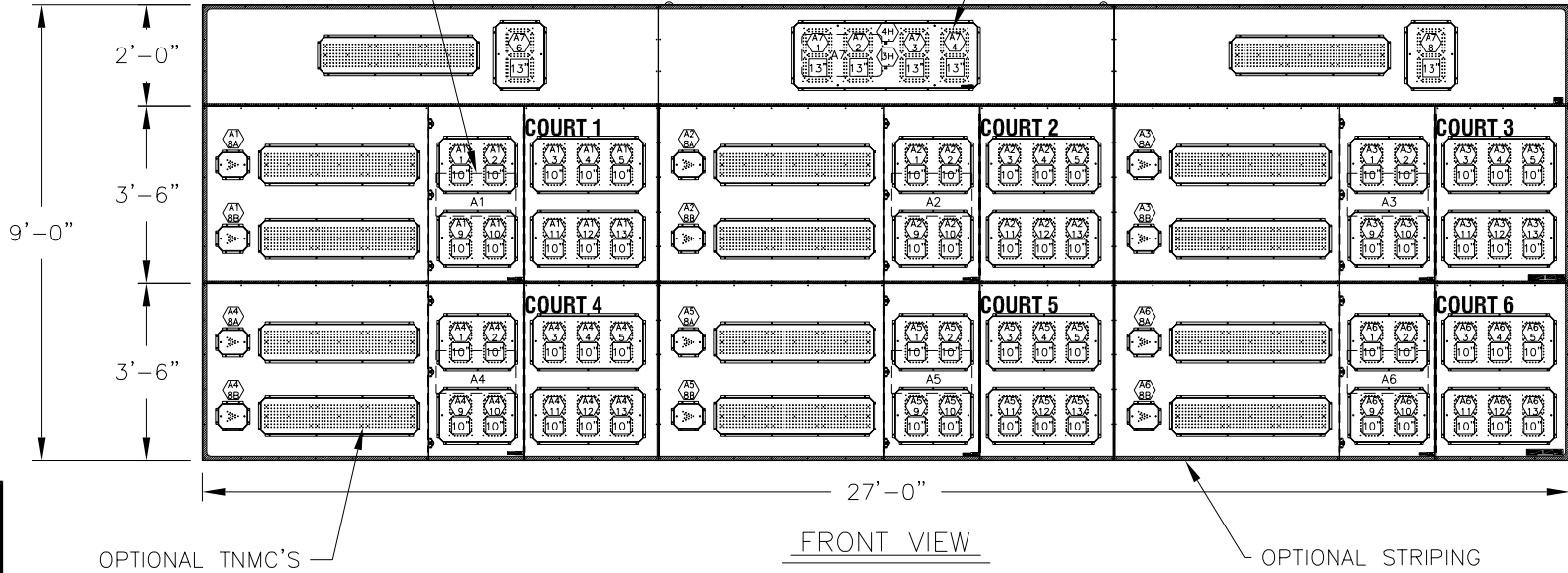

NOTES:

1. LIFTEYE IS TEMPORARY USE FOR LIFTING THE SCOREBOARD DURING INSTALLATION. DO NOT USE FOR PERMANENT INSTALLATION.
2. THE SCOREBOARD IS SHOWN WITH PANAVIEW DIGIT TECHNOLOGY. SEE DRAWING A-158550 FOR MORE DETAILS.
3. DISPLAY IS COMPRISED OF THREE (3) SECTIONS.

 = LED DRIVER NUMBER & LED DRIVER CONNCTOR WIRED TO THAT DIGIT

 = DIGIT SIZE

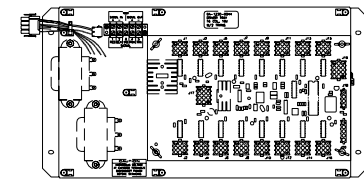

DRIVER DETAIL

SCALE X4

THE CONCEPTS EXPRESSED AND DETAILS SHOWN ON THIS DRAWING ARE CONFIDENTIAL AND PROPRIETARY. DO NOT REPRODUCE BY ANY MEANS, INCLUDING ELECTRONICALLY WITHOUT THE EXPRESSED WRITTEN CONSENT OF DAKTRONICS, INC. COPYRIGHT 2008 DAKTRONICS, INC.

PROJ: TENNIS SCOREBOARDS
 TITLE: COMPONENT LOCATION: TN-2551, INDOOR TENNIS
 DES. BY: KDRAGT DRAWN BY: KDRAGT DATE: 11 DEC 08
 REVISION APPR. BY: 1164-R03A-775742
 00 SCALE: 1=45

DAKTRONICS, INC. BROOKINGS, SD 57006

REV.	DATE	DESCRIPTION	BY	APPR.
------	------	-------------	----	-------

THE CONCEPTS EXPRESSED AND DETAILS SHOWN ON THIS DRAWING ARE CONFIDENTIAL AND PROPRIETARY. DO NOT REPRODUCE BY ANY MEANS, INCLUDING ELECTRONICALLY WITHOUT THE EXPRESSED WRITTEN CONSENT OF DAKTRONICS, INC. COPYRIGHT 2008 DAKTRONICS, INC.

PROJ: TENNIS SCOREBOARDS
 TITLE: COMPONENT LOCATION: TN-2553, INDOOR TENNIS
 DES. BY: KDRAGT DRAWN BY: VSHIRAL DATE: 11 DEC 08
 REVISION 00 APPR. BY: SCALE: 1=30 1164-R03A-776414

DAKTRONICS, INC. BROOKINGS, SD 57006

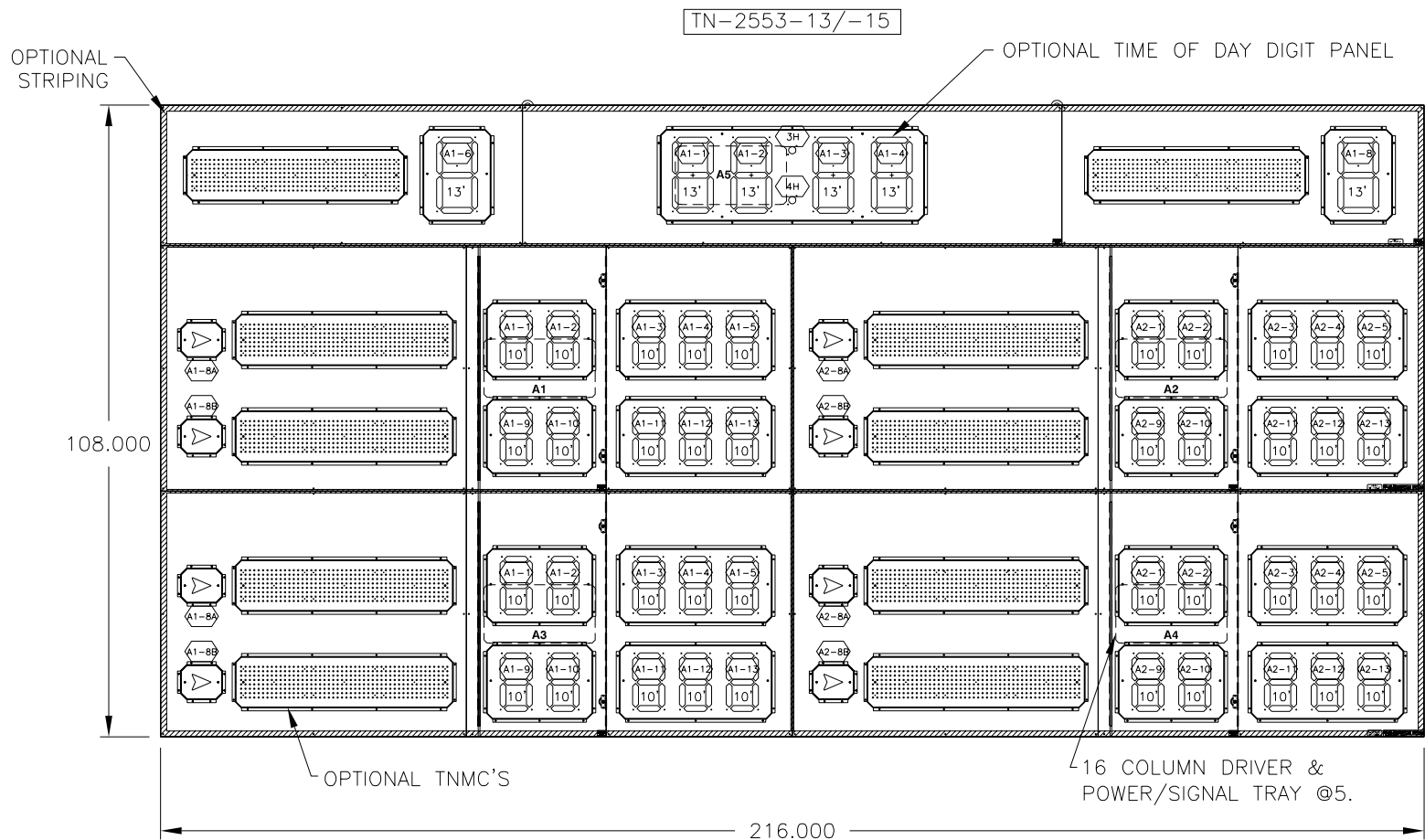

NOTES:

1. LIFTEYE IS FOR TEMPORARY USE FOR LIFTING THE SCOREBOARD DURING INSTALLATION. DO NOT USE FOR PERMANENT INSTALLATION.
2. THE SCOREBOARD IS SHOWN WITH UNIVIEW DIGIT TECHNOLOGY. SEE DRAWING A-158550 FOR MORE DETAILS.

 = LED DRIVER NUMBER & LED DRIVER CONNECTOR WIRED TO THAT DIGIT.

 = DIGIT SIZE

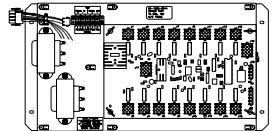

DRIVER DETAIL

SCALE X2

REV.	DATE	DESCRIPTION	BY	APPR.

PROJ: TENNIS SCOREBOARDS
 TITLE: COMPONENT LOCATION: TN-2550, INDOOR TENNIS
 DES. BY: KDRAGT DRAWN BY: KDRAGT DATE: 12 DEC 08
 REVISION APPR. BY: 1164-R03A-776724
 SCALE: 1=40
 DAKTRONICS, INC. BROOKINGS, SD 57006
 THE CONCEPTS EXPRESSED AND DETAILS SHOWN ON THIS DRAWING ARE CONFIDENTIAL AND PROPRIETARY. DO NOT REPRODUCE BY ANY MEANS, INCLUDING ELECTRONICALLY WITHOUT THE EXPRESSED WRITTEN CONSENT OF DAKTRONICS, INC. COPYRIGHT 2008 DAKTRONICS, INC.

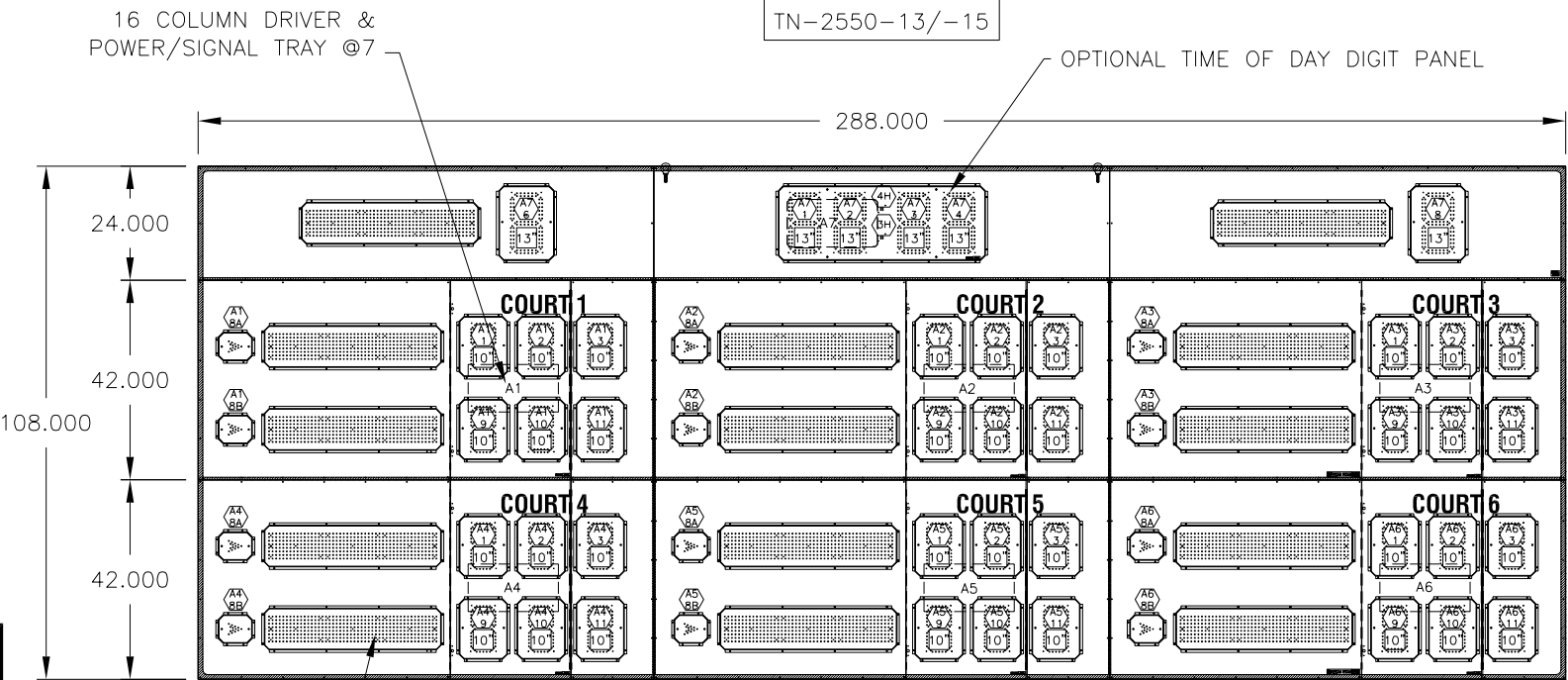

FRONT VIEW

NOTES:

1. LIFTEYE IS TEMPORARY USE FOR LIFTING THE SCOREBOARD DURING INSTALLATION. DO NOT USE FOR PERMANENT INSTALLATION.
2. THE SCOREBOARD IS SHOWN WITH PANAVIEW DIGIT TECHNOLOGY. SEE DRAWING A-158550 FOR MORE DETAILS.
3. DISPLAY IS COMPRISED OF THREE (3) SECTIONS.

 = LED DRIVER NUMBER & LED DRIVER CONNCTOR WIRED TO THAT DIGIT

 = DIGIT SIZE

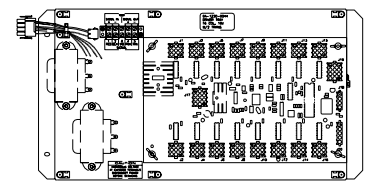

DRIVER DETAIL

SCALE X4

Appendix B: Scoreboard Options

<i>Drawing Title</i>	<i>Drawing Number</i>
Advertising/Identification Display Mounting	A-147668
Suspension Lift Eye Installation	A-148644
Installation, 6" Amber 8x48 TNMC	A-148701
ID or Ad Panel Mounting to Scoreboard	A-156134

MOUNT THE ANGLE (WITH 3/8" NUT) UNDER THE OVERHANG AT THE TOP OF THE SCOREBOARD. USE ONE ANGLE AT EACH END OF THE SCOREBOARD. SECURE WITH SCREWS INTO THE THREADED INSERTS MOUNTED IN THE SIDE OF THE SCOREBOARD.

INSTALL THE EYEBOLTS IN THE NUTS MOUNTED IN THE ANGLES.

ATTACH SUSPENSION CABLES TO EACH EYEBOLT WITH A SHACKLE (CLEVIS) AND PIN.

DAKTRONICS RECOMMENDS THAT TWO CABLES BE USED AT EACH END OF THE SCOREBOARD FOR REDUNDANCY. CABLES DIVERGE TO MINIMIZE SWINGING.

CABLES AND HARDWARE MUST BE SPECIFIED BY A LICENSED ENGINEER. THIS INSTALLATION METHOD MUST NOT BE USED TO SUPPORT SCOREBOARD WITH MESSAGE CENTERS AND BACKLIT AD PANELS ATTACHED.

TOTAL WEIGHT OF SCOREBOARD AND ATTACHED ACCESSORIES MUST NOT EXCEED 500 LB.

SUSPENSION HARDWARE IS FOR THE TOP OF THE SCOREBOARD ONLY. SCOREBOARD INSTALLATION WITH AD PANEL MUST NOT BE SUSPENDED FROM THE AD PANEL. THE SCOREBOARD MUST BE AT THE TOP.

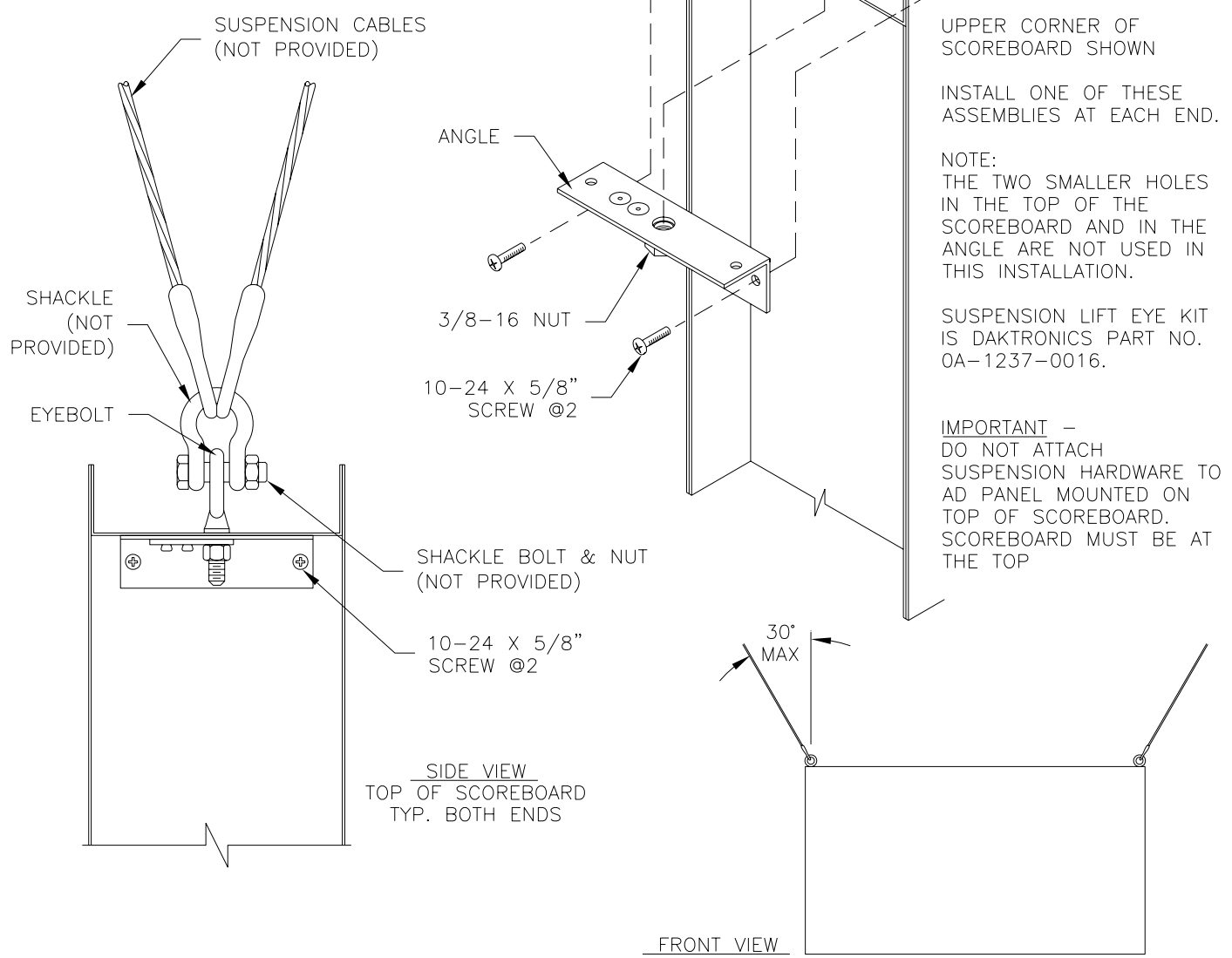

UPPER CORNER OF SCOREBOARD SHOWN
INSTALL ONE OF THESE ASSEMBLIES AT EACH END.

NOTE:
THE TWO SMALLER HOLES IN THE TOP OF THE SCOREBOARD AND IN THE ANGLE ARE NOT USED IN THIS INSTALLATION.

SUSPENSION LIFT EYE KIT IS DAKTRONICS PART NO. 0A-1237-0016.

IMPORTANT -
DO NOT ATTACH SUSPENSION HARDWARE TO AD PANEL MOUNTED ON TOP OF SCOREBOARD. SCOREBOARD MUST BE AT THE TOP

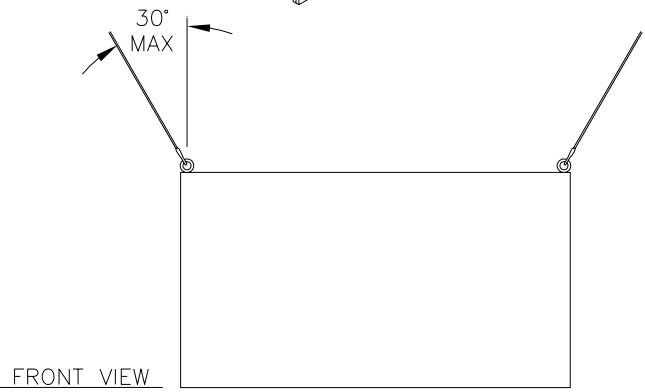

REV.	DATE	DESCRIPTION	BY	APPR.
03	23 OCT 02	REVERSED ORIENTATION OF NUT PLATE	AVB	
02	01 NOV 01	ADDED NOTES ABOUT NOT SUSPENDING FROM AN AD PANEL.	AVB	
01	27 SEP 01	ADDED KIT PART NUMBER AND NOTE THAT SHACKLE IS NOT PROVIDED.	AVB	

DAKTRONICS, INC. BROOKINGS, SD 57006			
PROJ:			
TITLE:	SUSPENSION LIFT EYE INSTALLATION		
DES. BY:	AVB	DRAWN BY:	A VANBEMMEL
		DATE:	09 MAY 01
REVISION	APPR. BY:	1237-R10A-148644	
	SCALE: 1=4		

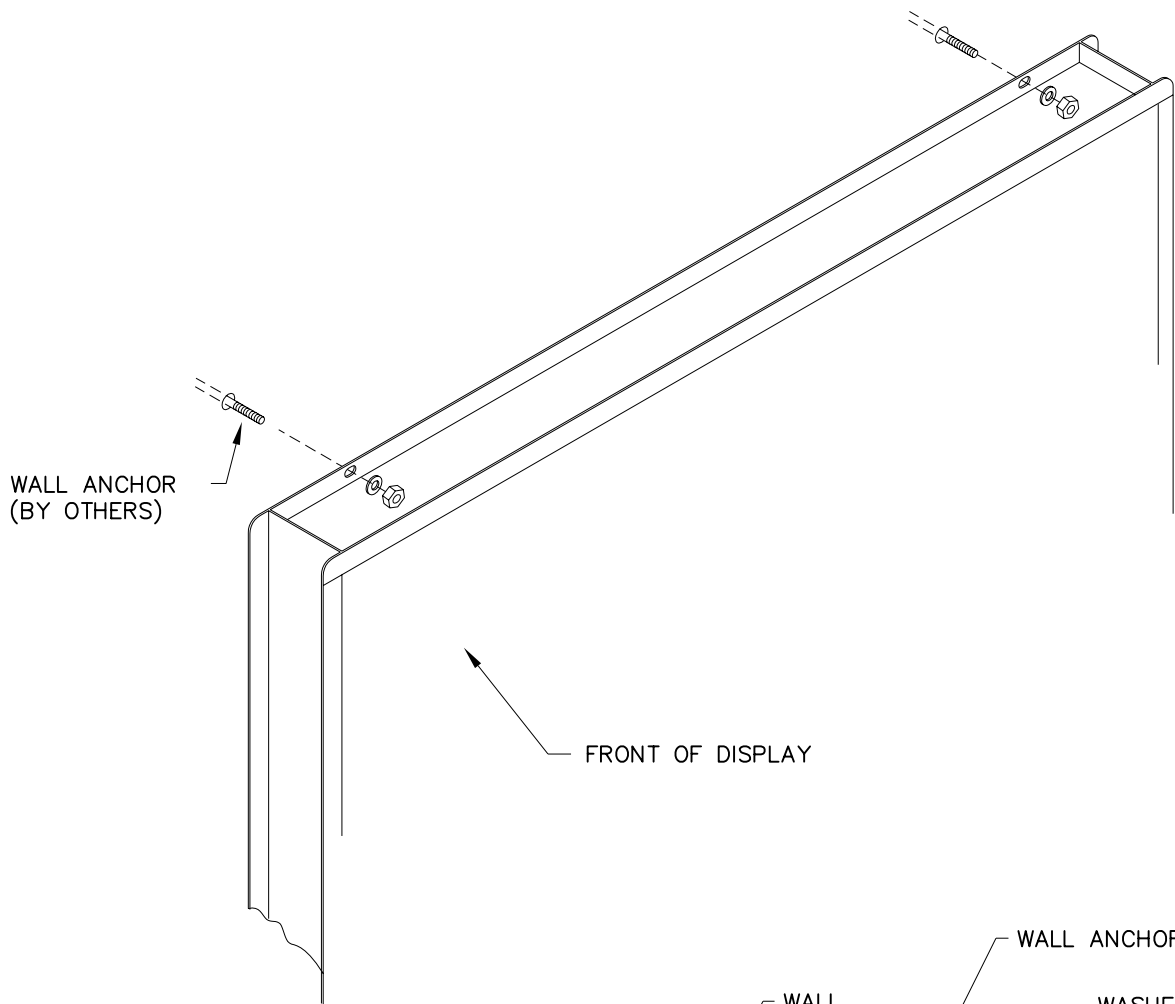

ATTACH THE DISPLAY TO THE WALL USING MOUNTING LOCATIONS PROVIDED. QUANTITY AND POSITION OF MOUNTING LOCATIONS WILL VARY WITH MODEL. USE THE APPROPRIATE ANCHORS FOR THE TYPE OF WALL.

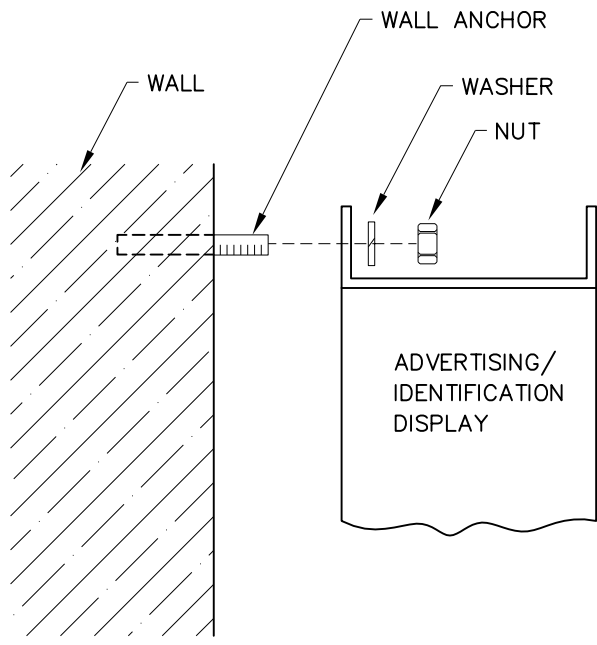

DAKTRONICS, INC. BROOKINGS, SD 57006	
PROJ:	
TITLE:	ADVERTISING/IDENTIFICATION DISPLAY MOUNTING
DES. BY:	JANDRE
DRAWN BY:	JANDRE
DATE:	16APR01
REVISION	APPR. BY:
	SCALE: NONE
1009-R10A-147668	

REV.	DATE	DESCRIPTION	BY	APPR.

TNMC INSTALLATION INSTRUCTIONS

1. REMOVE THE HOME/GUEST FACE PANELS FROM THE DISPLAY.
REFERENCE FIGURE 1
2. MOUNT THE POWER SUPPLY ASSEMBLY TO THE BACK OF THE TNMC PAN WITH HC-1470 SCREWS. THE WIRES ARE ALREADY CONNECTED TO THE POWER SUPPLY.
REFERENCE FIGURE 2
3. ROUTE THE 5V DC WIRES FROM THE POWER SUPPLY THROUGH THE OPENING TO THE TNMC LOCATIONS. ROUTE THE 120V POWER INTERCONNECT CABLE BETWEEN THE POWER SUPPLIES AND CONNECT. ROUTE THE POWER INPUT CABLE FROM THE HOME TNMC'S POWER SUPPLY TO THE 2-PIN PLUG AT THE DRIVER.
REFERENCE FIGURE 3
4. INSTALL THE SIGNAL HARNESS. ROUTE THE SIGNAL HARNESS FROM TB-31 AT THE DRIVER TO THE TNMC LOCATIONS.
REFERENCE FIGURE 3
5. CONNECT THE POWER AND SIGNAL TO THE TNMCS.
REFERENCE FIGURE 3

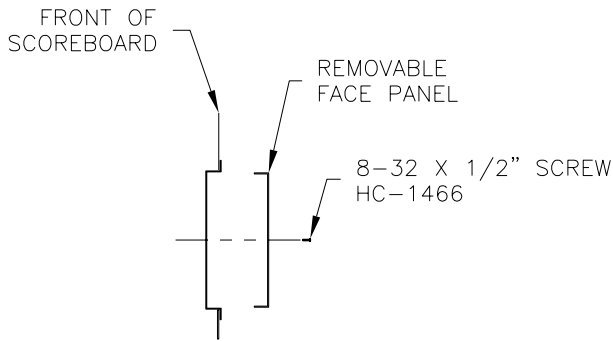

FIGURE 1

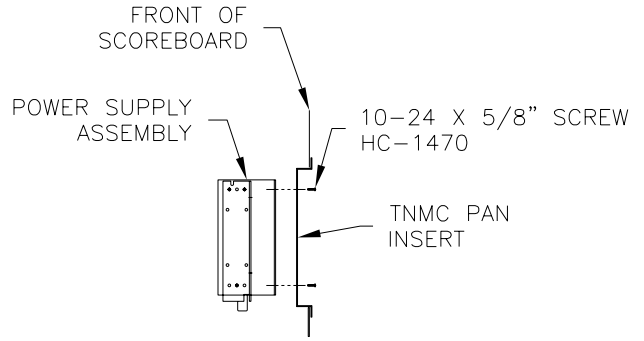

FIGURE 2

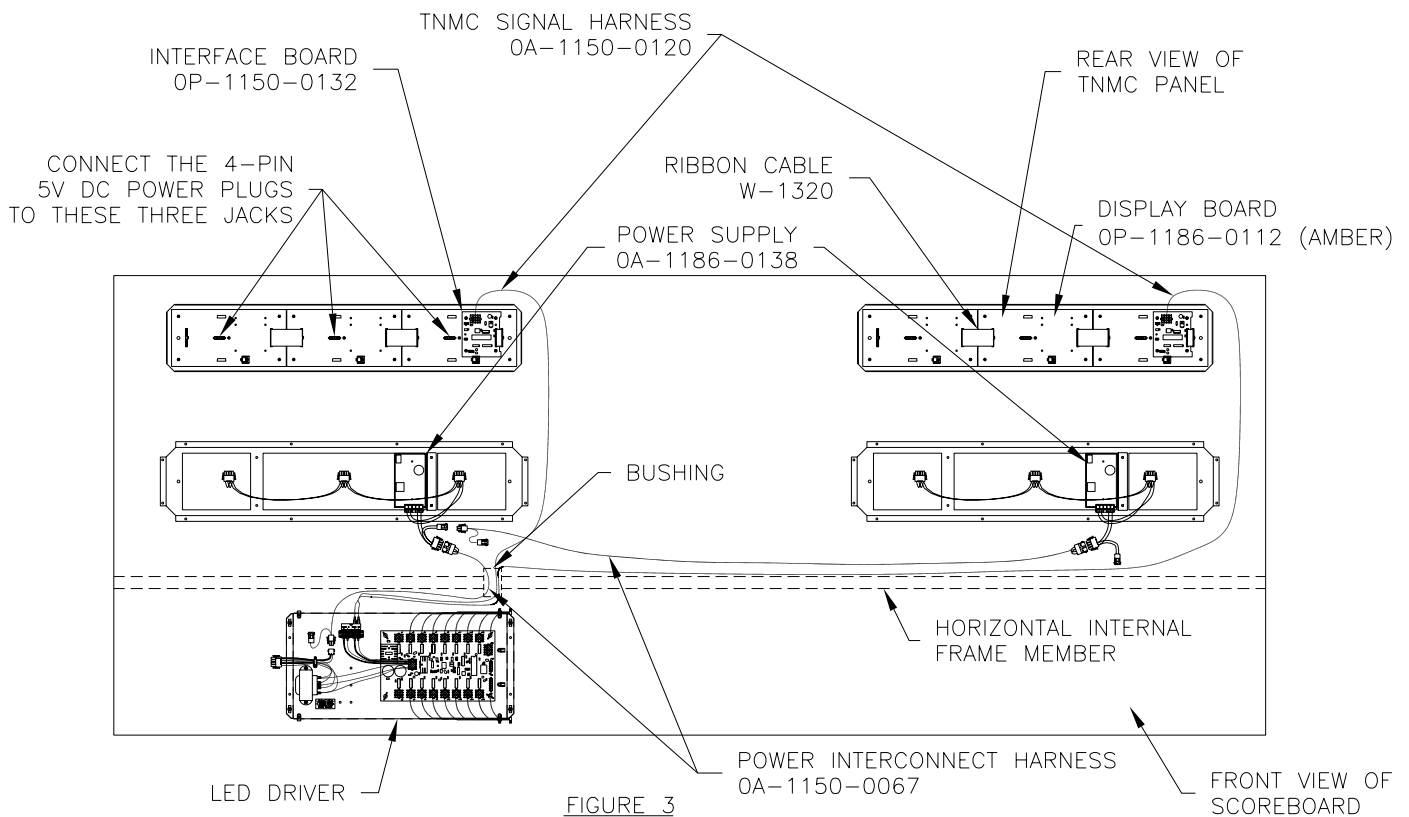
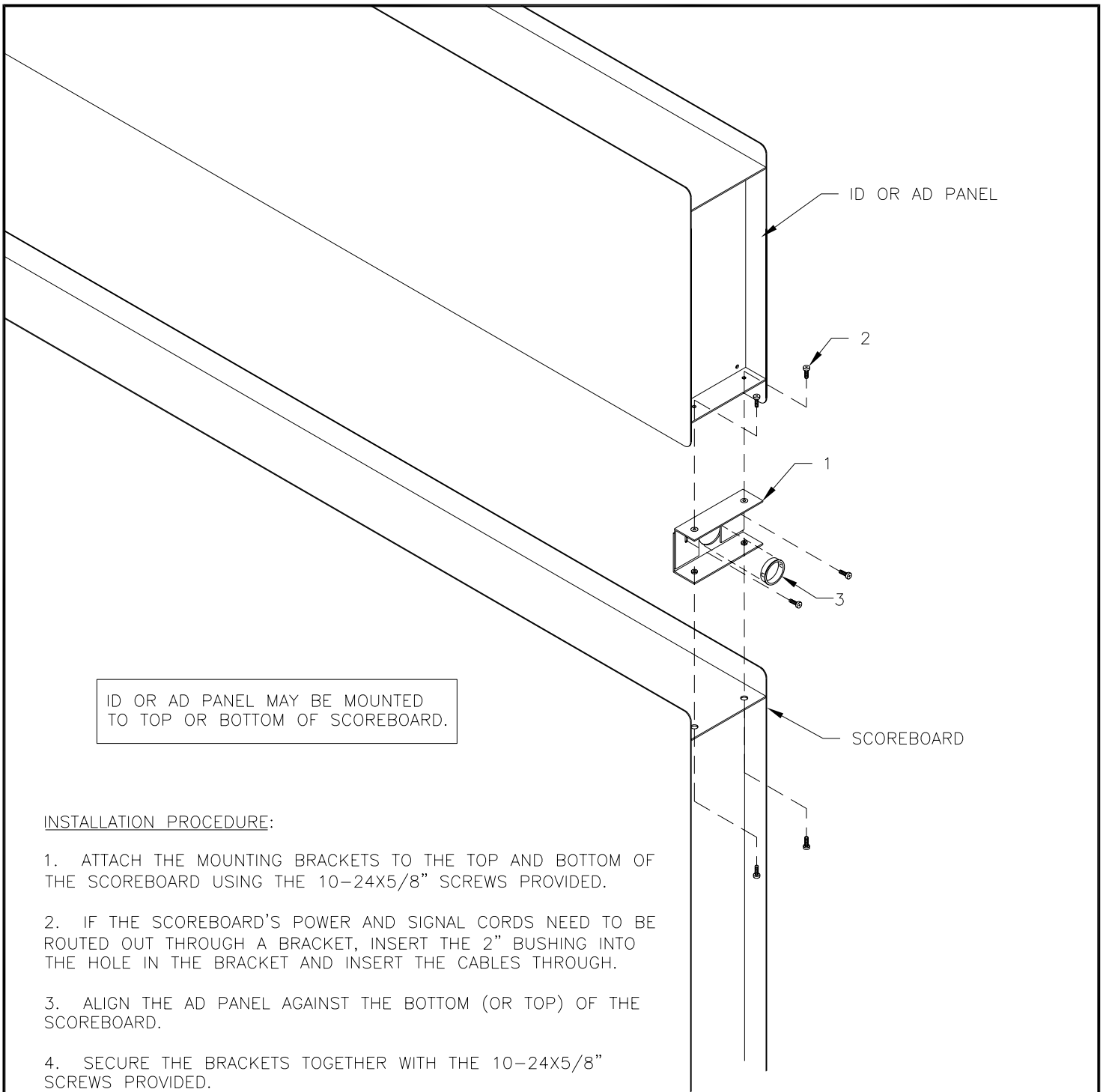

FIGURE 3

DAKTRONICS, INC. BROOKINGS, SD 57006			
PROJ: TUFF SPORT SCOREBOARDS			
TITLE: INSTALLATION, 6" AMBER 8X48 TNMC			
DES. BY: E REBHAWN		DRAWN BY: E REBHAWN	
		DATE: 10 MAY 01	
REVISION	APPR. BY:	1237-E10A-148701	
	SCALE: 1=20		

REV.	DATE	DESCRIPTION	BY	APPR.



ID OR AD PANEL MAY BE MOUNTED TO TOP OR BOTTOM OF SCOREBOARD.

INSTALLATION PROCEDURE:

1. ATTACH THE MOUNTING BRACKETS TO THE TOP AND BOTTOM OF THE SCOREBOARD USING THE 10-24X5/8" SCREWS PROVIDED.
2. IF THE SCOREBOARD'S POWER AND SIGNAL CORDS NEED TO BE ROUTED OUT THROUGH A BRACKET, INSERT THE 2" BUSHING INTO THE HOLE IN THE BRACKET AND INSERT THE CABLES THROUGH.
3. ALIGN THE AD PANEL AGAINST THE BOTTOM (OR TOP) OF THE SCOREBOARD.
4. SECURE THE BRACKETS TOGETHER WITH THE 10-24X5/8" SCREWS PROVIDED.

DESCRIPTION	PART NUMBER	QTY
1. MOUNTING BRACKETS	0S-1237-0058	2
2. SCREW, 10-24x5/8	HC-1022	12
3. BUSHING, 2.0 Ø	HE-1051	2

REV.	DATE	DESCRIPTION	BY	APPR.
02	18 JUL 06	REPLACED 0M-150458 BRKT WITH 0M-278266-A AND 0M-278266-B BRKTS	KAS	
01	20 JAN 03	REPLACED HC-1470 WITH HC-1022 RIVETS	RJC	

DAKTRONICS, INC. BROOKINGS, SD 57006			
PROJ: TUFF SPORT SCOREBOARDS			
TITLE: ID OR AD PANEL MOUNTING TO SCOREBOARD			
DES. BY: BPETERSON		DRAWN BY: JJSYRSTAD	
		DATE: 20 SEP 01	
REVISION		APPR. BY:	
02		SCALE: NONE	
1237-R04A-156134			

Appendix C: Schematic Drawings

<i>Drawing Title</i>	<i>Drawing Number</i>
Schematic; 3/4" & 1" TNMCs.....	B-146975
Schematic, 16V 1 Driver, 120 or 230VAC	A-158348
Schematic- 3 Court Horizontal Section- Indoor	C-261649
Schematic: TN-25XX- Team Score w/ TNMC and TOD Clock	B-261704
Schematic, 1 Driver w/ TNMCs, 120VAC or 230VAC.....	B-281962
Schematic- TN-25XX Two Court- Horizontal Section.....	B-282123

Models	Drawing Title	Drawing
TN-2501 TN-2503 TN-2504 TN-2505	Schematic, 16V 1 Driver, 120 or 230VAC	A-158348
TN-2550 TN-2551	Schematic- 3 Court Horizontal Section- Indoor	C-261649
TN-2552 TN-2553	Schematic- TN-25XX Two Court- Horizontal Section	B-282123
Single-Court w/TNMC	Schematic, 1 Driver w/ TNMCs, 120VAC or 230VAC	B-281962
Multi-Court w/TNMC	Schematic: TN-25XX- Team Score w/ TNMC and TOD Clock	B-261704

REAR VIEW

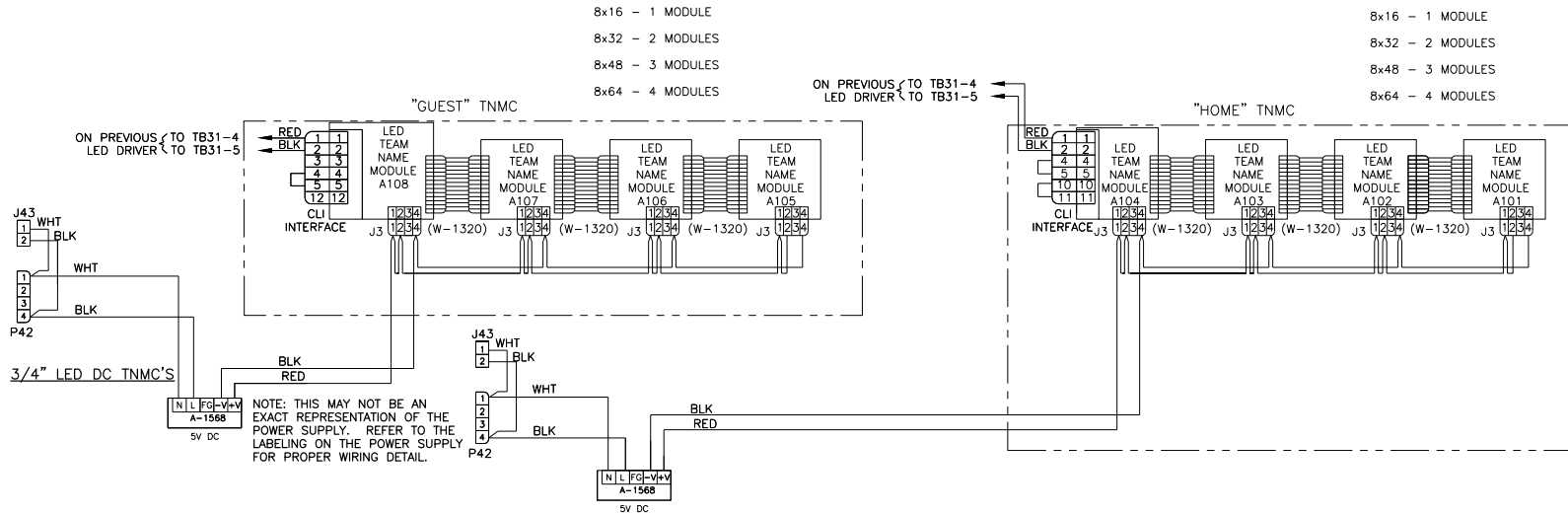

REAR VIEW

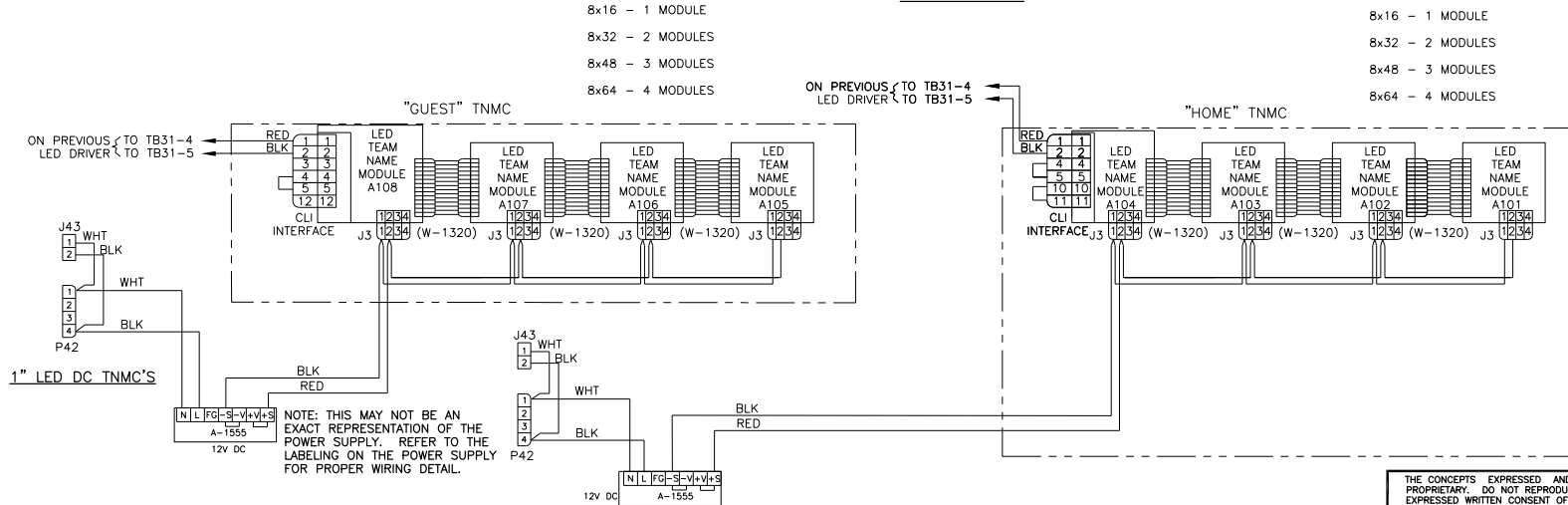

THE CONCEPTS EXPRESSED AND DETAILS SHOWN ON THIS DRAWING ARE CONFIDENTIAL AND PROPRIETARY. DO NOT REPRODUCE BY ANY MEANS, INCLUDING ELECTRONICALLY WITHOUT THE EXPRESSED WRITTEN CONSENT OF DAKTRONICS, INC. COPYRIGHT 2003 DAKTRONICS, INC.

03		29 DEC 08	REVISE DETAIL OF P42 PER ECO 65496. MOVED PIN 2 TO PIN 4. ORIGINAL CHANGE WAS MADE ON 5 OCT 04	DKD		DAKTRONICS, INC. BROOKINGS, SD 57006	
02		06 AUG 03	CHANGED TO B SIZE DWG ADDED 3RD MODULE TO SHOW 8X64 CONFIGURATION	TLH	MWM	PROJ: SCHEMATIC: 3/4" AND 1" DC TNMC'S	
01		25 JUN 03	SWAPPED N & L ON A-1568 PER ECO #31661	RASMUS	CMC	DES. BY: DRAWN BY: JSPAHR DATE: 29 MAR 01	
REV.	DATE	DESCRIPTION		BY	APPR.	REVISION	APPR. BY: SCALE: NONE 1152-R03B-146975

120V AND 230VAC MODELS

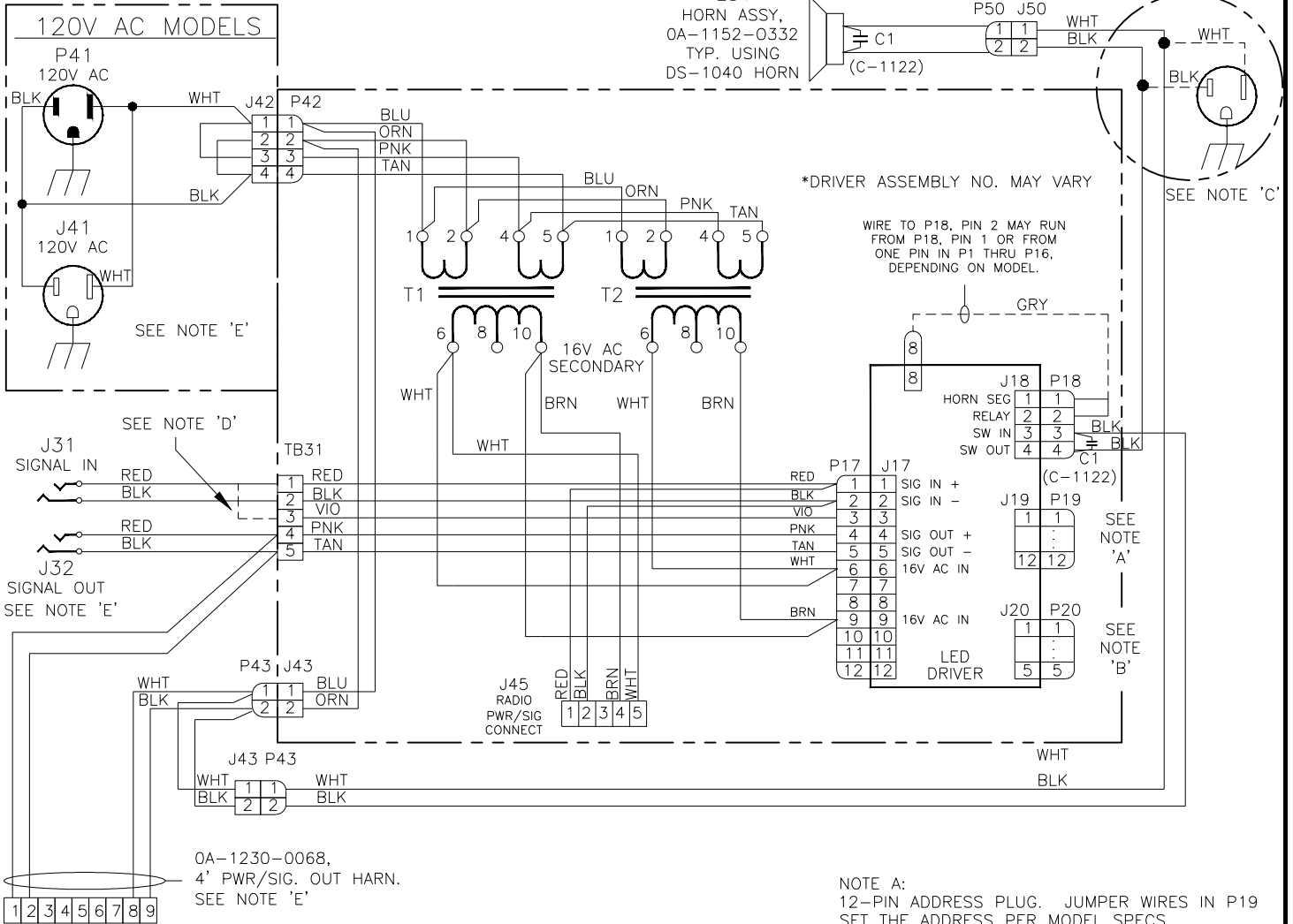

NOTE A:
12-PIN ADDRESS PLUG. JUMPER WIRES IN P19 SET THE ADDRESS PER MODEL SPECS.

NOTE B:
5-PIN PROTOCOL PLUG. JUMPER WIRES IN P20 SET THE PROTOCOL PER SYSTEM SPECS.

NOTE 'C':
J-1041 @1 & E-1047 @2, USED FOR EXTERNAL HORN APPLICATIONS. NOT AVAILABLE ON SOME MODELS.

NOTE D:
FOR SWIM SYSTEMS CONTROLLED BY POWER TIME.

NOTE 'E':
NOT USED IN SOME MODELS.

120V AC MODELS

SPECIFICATION LABEL DATA	
MODEL NO:	(PER ORDER)
VOLTS:	120 VAC, SINGLE PHASE
WATTS:	200
AMPS:	1.7

230V AC MODELS

SPECIFICATION LABEL DATA	
MODEL NO:	(PER ORDER)
VOLTS:	230 VAC, SINGLE PHASE
WATTS:	200
AMPS:	.9

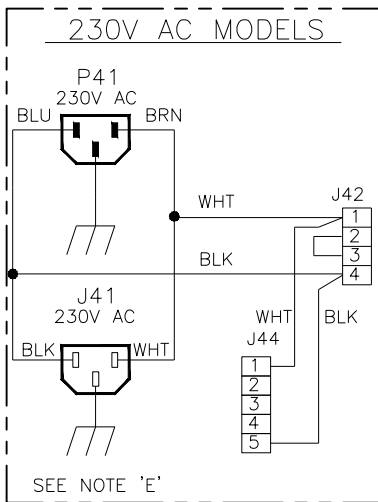

REV	DATE:	DESCRIPTION	BY:
05	13 FEB 03	MOVED TAP 8 TO A DOUBLE CRIMP ON TAP 10 ON TRANSFORMER T1 CONNECTED TO J45. UPDATED TITLE TO SAY 230VAC ALSO	CME
04	15 APR 02	ADDED 4" PWR/SIG OUT HARN. THAT IS IN SOME TUFF SPORT MODELS.	MWM
03	23 JAN 02	CHANGED TITLE FROM SCHEMATIC, 16V LED DRVR TO SCHEMATIC, 16V 1 DRIVER, 120 VAC	ALG
02	17 DEC 01	CHANGED DRIVER BLOCK LAYOUT.	MWM
01	11 NOV 01	UPDATED NOTES AND 230V POWER BLOCK	MWM

DAKTRONICS, INC. BROOKINGS, SD 57006		THE CONCEPTS EXPRESSED AND DETAILS SHOWN ON THIS DRAWING ARE CONFIDENTIAL AND PROPRIETARY. DO NOT REPRODUCE BY ANY MEANS WITHOUT THE EXPRESSED WRITTEN CONSENT OF DAKTRONICS, INC. COPYRIGHT 2011 DAKTRONICS, INC.	
DO NOT SCALE DRAWING			
PROJ: INDOOR UNIFORM LED DIGIT			
TITLE: SCHEMATIC- 16V 1 DRIVER- 120 OR 230VAC			
DESIGN: MMILLER		DRAWN: MMILLER	
SCALE: 1 = 1		DATE: 02 NOV 01	
SHEET	REV	JOB NO:	FUNC-TYPE-SIZE
	07	P1230	R-03-A
			158348

REV	DATE:	DESCRIPTION	BY:
07	01 JUN 11	ADDED CAP DETAIL ON P18 AT DRIVER LOCATION FOR THE HORN HARNESS. UPDATED LS1 TEXT	MWM
06	11 JAN 05	ADDED WIRE COLORS TO 230V PLUG PER ECO# 042552	RT

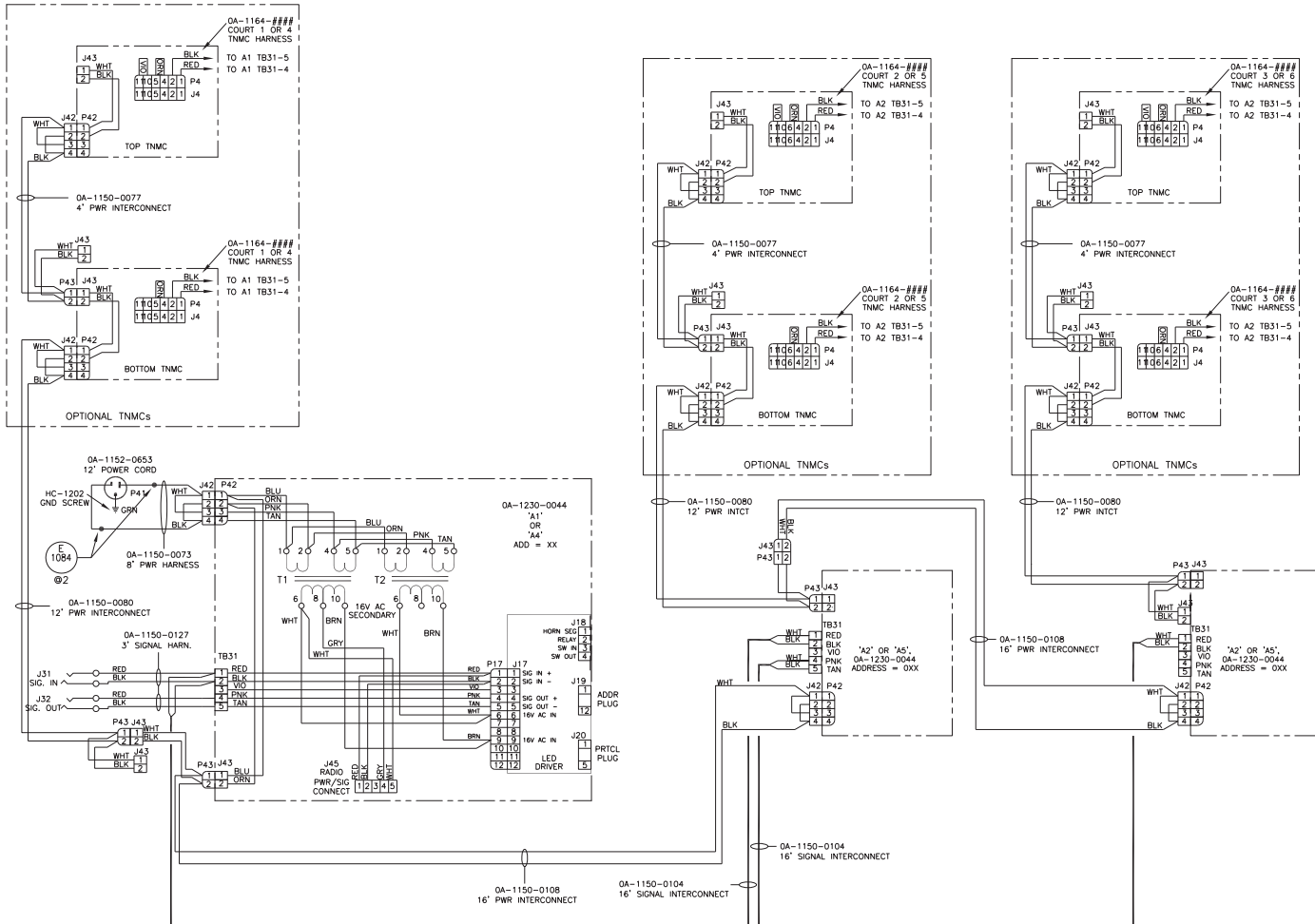

FOR TNMC OPTION
CABLES FOUND IN FINAL ASSY.

COURT 1	OA-1164-0260
COURT 2	OA-1164-0261
COURT 3	OA-1164-0262
COURT 4	OA-1164-0263
COURT 5	OA-1164-0264
COURT 6	OA-1164-0265

NOTE: NOT ALL DISPLAYS GET TNMC OPTION.
LOAD HARNESSES EITHER WAY.

COURT 1
J-19 ADDRESS PLUG

	12	11	10	9	8	7	6	5	4	3	2
PIN 12	PIN 11	PIN 10	PIN 9	PIN 8	PIN 7	PIN 6	PIN 5	PIN 4	PIN 3	PIN 2	
A1	11	12	0	0	0	0	1	0	1	0	0
GUEST TNMC	221	0	0	0	0	0	1	0	1	0	0
HOME TNMC	221	0	1	0	0	0	1	0	1	0	0

COURT 2
J-19 ADDRESS PLUG

	12	11	10	9	8	7	6	5	4	3	2
PIN 12	PIN 11	PIN 10	PIN 9	PIN 8	PIN 7	PIN 6	PIN 5	PIN 4	PIN 3	PIN 2	
A1	12	0	0	0	0	1	1	0	1	0	0
GUEST TNMC	222	0	0	0	0	1	1	0	1	0	0
HOME TNMC	222	0	1	0	0	1	1	0	1	0	0

COURT 3
J-19 ADDRESS PLUG

	12	11	10	9	8	7	6	5	4	3	2
PIN 12	PIN 11	PIN 10	PIN 9	PIN 8	PIN 7	PIN 6	PIN 5	PIN 4	PIN 3	PIN 2	
A1	13	0	0	0	0	1	1	0	1	0	0
GUEST TNMC	223	0	0	0	0	1	1	0	1	0	0
HOME TNMC	223	0	1	0	0	1	1	0	1	0	0

COURT 4
J-19 ADDRESS PLUG

	12	11	10	9	8	7	6	5	4	3	2
PIN 12	PIN 11	PIN 10	PIN 9	PIN 8	PIN 7	PIN 6	PIN 5	PIN 4	PIN 3	PIN 2	
A1	14	0	0	0	0	1	1	0	1	0	0
GUEST TNMC	224	0	0	0	0	1	1	0	1	0	0
HOME TNMC	224	0	1	0	1	0	1	0	1	0	0

COURT 5
J-19 ADDRESS PLUG

	12	11	10	9	8	7	6	5	4	3	2
PIN 12	PIN 11	PIN 10	PIN 9	PIN 8	PIN 7	PIN 6	PIN 5	PIN 4	PIN 3	PIN 2	
A1	15	0	0	0	0	1	1	0	1	0	0
GUEST TNMC	225	0	0	0	0	1	1	0	1	0	0
HOME TNMC	225	0	1	0	1	0	1	0	1	0	0

COURT 6
J-19 ADDRESS PLUG

	12	11	10	9	8	7	6	5	4	3	2
PIN 12	PIN 11	PIN 10	PIN 9	PIN 8	PIN 7	PIN 6	PIN 5	PIN 4	PIN 3	PIN 2	
A1	16	0	0	0	1	1	0	3	0	0	0
GUEST TNMC	226	0	0	0	1	1	0	3	0	0	0
HOME TNMC	226	0	1	0	1	1	0	3	0	0	0

WITHOUT TNMCs	WITH 3/4" TNMCs	WITH 1" TNMCs
SYSTEM OPERATION REQUIREMENTS	SYSTEM OPERATION REQUIREMENTS	SYSTEM OPERATION REQUIREMENTS
SYSTEM CONTROL CONSOLE DAK TENNIS SOFTWARE	SYSTEM CONTROL CONSOLE DAK TENNIS SOFTWARE	SYSTEM CONTROL CONSOLE DAK TENNIS SOFTWARE
SYSTEM RISER # NA	SYSTEM RISER # NA	SYSTEM RISER # NA
DISPLAY F ASSY DWG NA	DISPLAY F ASSY DWG NA	DISPLAY F ASSY DWG NA
SYSTEM VOLTAGE 120 VAC	SYSTEM VOLTAGE 120 VAC	SYSTEM VOLTAGE 120 VAC
HIGH LEG (AMPS) 5	HIGH LEG (AMPS) 7.5	HIGH LEG (AMPS) 10.0
MAXIMUM WATTS 600	MAXIMUM WATTS 900	MAXIMUM WATTS 1200
SPORT INSERT # NA	SPORT INSERT # NA	SPORT INSERT # NA
OPERATING CODE # NA	OPERATING CODE # NA	OPERATING CODE # NA

NOTE: FOR TESTING
- USE THE ALLSPORT 5000 AND CODE 229 FOR TESTING.
- TEST USING STANDARD SCOREBOARD TESTING PROCEDURES.
- WHEN TESTING IS COMPLETE INSTALL CORRECT ADDRESS PLUGS AND HARNESSES.

NOTE: INSTALL SPECIFIED SIGNAL KIT AND TEST.

03 9 FEB 09	ADDED TNMC CABLE PART NUMBER CHART	MRH	THE CONCEPTS EXPRESSED AND DETAILS SHOWN ON THIS DRAWING ARE CONFIDENTIAL AND PROPRIETARY. DO NOT REPRODUCE BY ANY MEANS, INCLUDING ELECTRONICALLY WITHOUT THE EXPRESSED WRITTEN CONSENT OF DAKTRONICS, INC.
02 13 APR 07	CORRECTED THE PIN OUT CHART FOR ADDRESS 16. IT WAS SHOWING THE ADDRESS 33 SETTING (PINS 03-0333)	MMW	DAKTRONICS, INC. BROOKINGS, SD 57006
01 8 JAN 07	REVISED SCHEMATIC, ADDRESS ADDRESS CHARTS, AND TESTING NOTE	DMD	PROJ: TENNIS SCOREBOARDS
REV.	DATE	DESCRIPTION	BY
			APPR.
			03
			SCALE: NONE
			1164-R03C-261649
			DATE: 10 JAN 06
			DRAWN BY: APAGE
			DES. BY: MMILLER
			TITLE: SCHEMATIC- 3 COURT HORIZONTAL SECTION- INDOOR

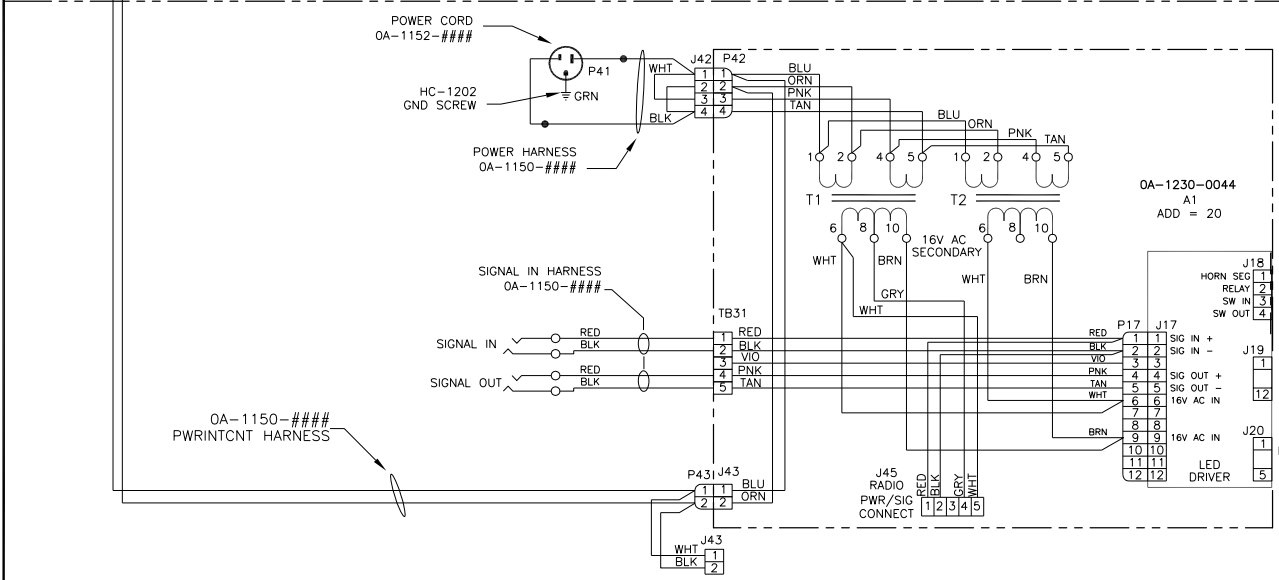
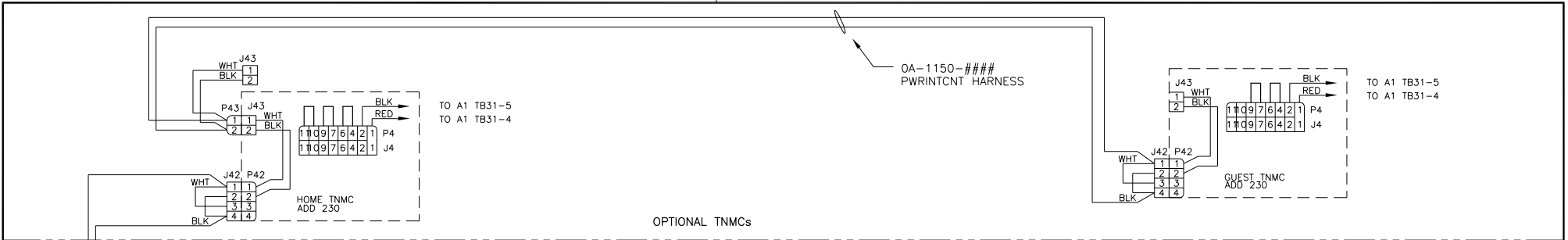

ADDRESS TABLE:

	12	11	10	9	8	7	6	5	4	3	2
PIN	PIN	PIN	PIN	PIN	PIN	PIN	PIN	PIN	PIN	PIN	PIN
GUEST TNMC	230	0	0	1	0	1	0	0	0	0	0
HOME TNMC	230	0	1	1	0	1	0	0	0	0	0
(A1)CLOCK SCORE	20	0	0	0	1	0	1	0	0	0	0

FOR TESTING PURPOSES

- USE THE ALLSPORT 5000, WITH INSERT LL-2483, AND CODE 229
- TEST USING STANDARD SCORBOARD TESTING PROCEDURES.
- WHEN TESTING IS COMPLETE INSTALL CORRECT ADDRESS PULGS AND HARNESSSES.

NOTE:BEFORE FEB 09 TNMC ADDRESS & SIGNAL HARNESS ASSEMBLY PACKET IS OA-1164-0165.

- REFER TO DIGIT DESIGNATION DRAWING FOR HARNESS LENGTHS AND PART NUMBERS.
- AFTER FEB 09 REFER TO OA-1164-0083 FOR TNMC INTCNT.

TIME OF DAY OPTION PROTOCOL PLUG. CONNECT OA-1150-0118 HERE

WITHOUT TNMCs AND WITH OR WITHOUT T.O.D.

SYSTEM OPERATION REQUIREMENTS	
SYSTEM CONTROL CONSOLE	
A/S	5010
OA-1196-0001	
SYSTEM RISER #	NA
DISPLAY F ASSY DWG	
SYSTEM VOLTAGE	120 VAC
HIGH LEG (AMPS)	1.7
MAXIMUM WATTS	200
SPORT INSERT #	LL-2483
OPERATING CODE #	DAKTENNIS

WITH 3/4" TNMCs AND WITH OR WITHOUT T.O.D.

SYSTEM OPERATION REQUIREMENTS	
SYSTEM CONTROL CONSOLE	
A/S	5010
OA-1196-0001	
SYSTEM RISER #	NA
DISPLAY F ASSY DWG	
SYSTEM VOLTAGE	120 VAC
HIGH LEG (AMPS)	2.5
MAXIMUM WATTS	300
SPORT INSERT #	LL-2483
OPERATING CODE #	DAKTENNIS

WITH 1" TNMCs AND WITH OR WITHOUT T.O.D.

SYSTEM OPERATION REQUIREMENTS	
SYSTEM CONTROL CONSOLE	
A/S	5010
OA-1196-0001	
SYSTEM RISER #	NA
DISPLAY F ASSY DWG	
SYSTEM VOLTAGE	120 VAC
HIGH LEG (AMPS)	3.4
MAXIMUM WATTS	400
SPORT INSERT #	LL-2483
OPERATING CODE #	DAKTENNIS

REV.	DATE	DESCRIPTION	BY	APPR.
05	17 FEB 09	UPDATED ADDRESS TABLE FOR HOME TNMC	MRH	
04	3 FEB 09	UPDATED NOTE TO INCLUDE UPDATED TNMC INTNT ASSEMBLY NUMBER.	MRH	
03	07 DEC 07	CHANGED POWER CHARTS TO INCLUDE T.O.D. OPTIONS.	AMG	
02	26 OCT 07	CHG TEST CODE	KZB	
01	13 AUG 06	REVISED TO BE STANDARD RISER FOR TN-25XX SERIES TENNIS BOARDS.	DMD	

THE CONCEPTS EXPRESSED AND DETAILS SHOWN ON THIS DRAWING ARE CONFIDENTIAL AND PROPRIETARY. DO NOT REPRODUCE BY ANY MEANS, INCLUDING ELECTRONICALLY WITHOUT THE EXPRESSED WRITTEN CONSENT OF DAKTRONICS, INC. COPYRIGHT 2006 DAKTRONICS, INC.

DAKTRONICS, INC. BROOKINGS, SD 57006

PROJ: TENNIS SCOREBOARD
 TITLE: SCHEMATIC: TN-25XX- TEAM SCORE W/TNMC AND TOD CLK
 DES. BY: APAGE DRAWN BY: APAGE DATE: 10 JAN 06

REVISION APPR. BY: SCALE: NONE 1164-R03B-261704

120V AND 230VAC MODELS

230V AC MODELS

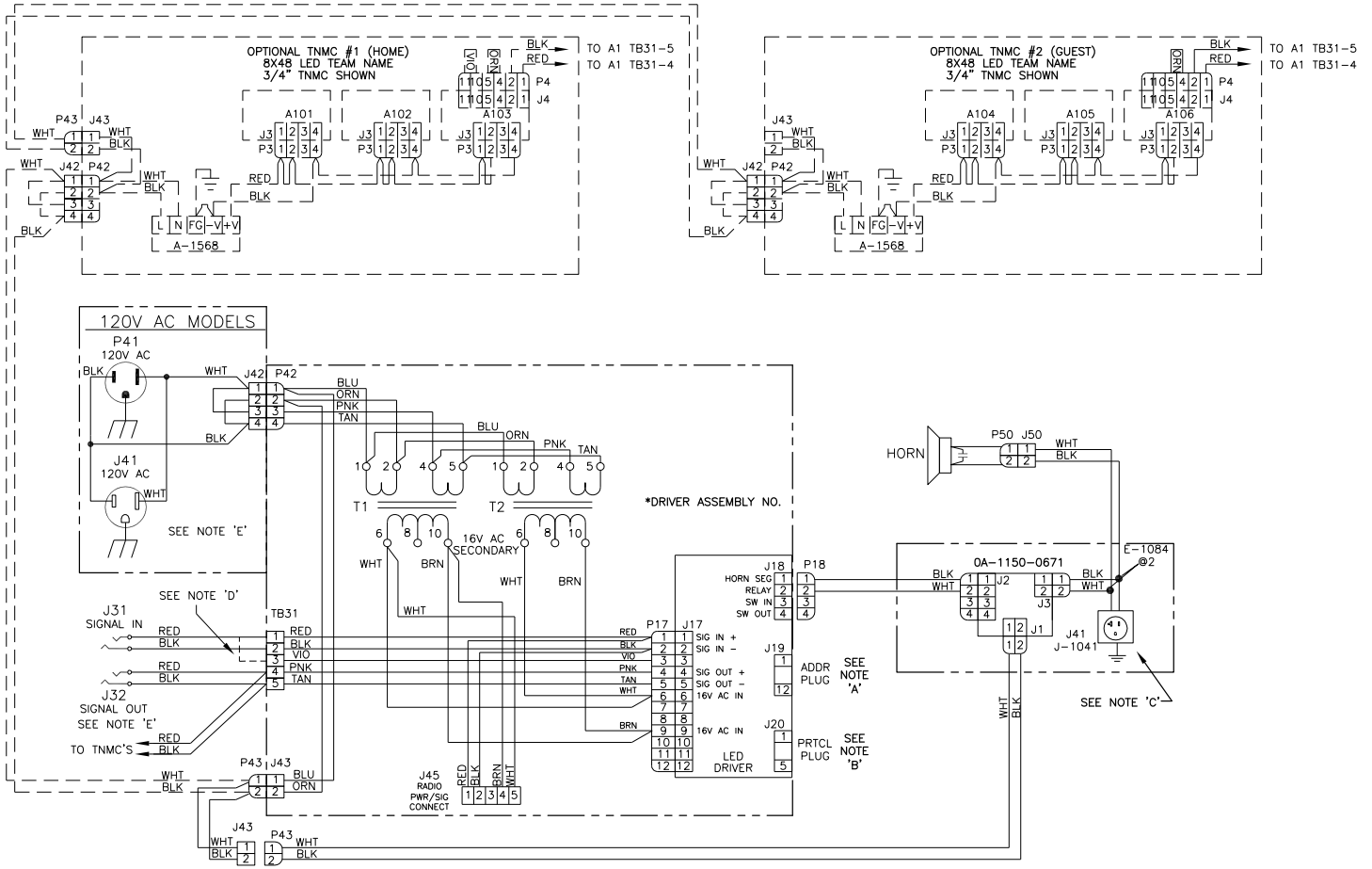
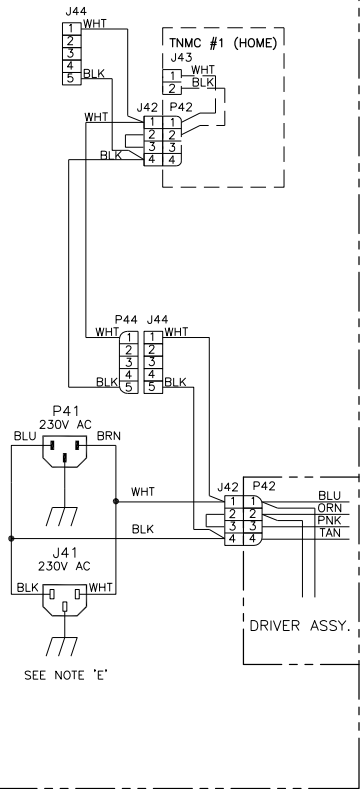

120V AC MODELS

SPECIFICATION LABEL DATA
 MODEL NO: (PER ORDER)
 VOLTS: 120 VAC, SINGLE PHASE
 WATTS: 200
 AMPS: 1.7

230V AC MODELS

SPECIFICATION LABEL DATA
 MODEL NO: (PER ORDER)
 VOLTS: 230 VAC, SINGLE PHASE
 WATTS: 200
 AMPS: .9

- OPTIONAL TNMC AND WIRING
- NOTE A:
 12-PIN ADDRESS PLUG. JUMPER WIRES IN P19 SET THE ADDRESS PER MODEL SPECS.
- NOTE B:
 5-PIN PROTOCOL PLUG. JUMPER WIRES IN P20 SET THE PROTOCOL PER SYSTEM SPECS.
- NOTE 'C':
 J-1041 @1 & E-1047 @2, USED FOR EXTERNAL HORN APPLICATIONS. NOT AVAILABLE ON SOME MODELS.
- NOTE D:
 FOR SWIM SYSTEMS CONTROLLED BY POWER TIME.
- NOTE 'E':
 NOT USED IN SOME MODELS.

THE CONCEPTS EXPRESSED AND DETAILS SHOWN ON THIS DRAWING ARE CONFIDENTIAL AND PROPRIETARY. DO NOT REPRODUCE BY ANY MEANS, INCLUDING ELECTRONICALLY WITHOUT THE EXPRESSED WRITTEN CONSENT OF DAKTRONICS, INC. COPYRIGHT 2006 DAKTRONICS, INC.

DAKTRONICS, INC. BROOKINGS, SD 57006
 PROJ: INDOOR LED, TUFF SPORT BOARDS
 TITLE: SCHEMATIC, 1 DRIVER W/ TNMC'S, 120VAC OR 230VAC
 DES. BY: DDINING DRAWN BY: DDINING DATE: 13 AUG 06

REV.	DATE	DESCRIPTION	BY	APPR.
00				

REVISION APPR. BY: MMILLER SCALE: NONE 1230-R03B-281962

TOP LEFT TNMC SECTIONS,
ADD = 221

MIDDLE LEFT TNMC SECTIONS,
ADD = 222

BOTTOM LEFT SECTIONS,
ADD = 223

TOP RIGHT TNMC SECTIONS,
ADD = 224

MIDDLE RIGHT TNMC SECTIONS,
ADD = 225

BOTTOM RIGHT SECTIONS,
ADD = 226

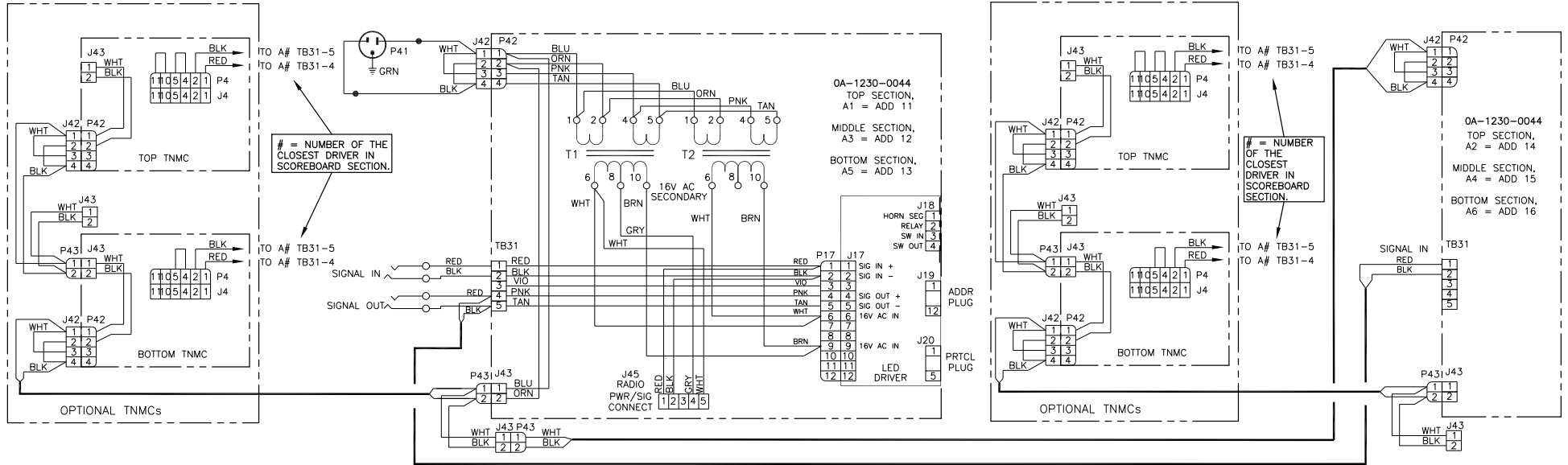

WITHOUT TNMCs

SYSTEM OPERATION REQUIREMENTS	
SYSTEM CONTROL CONSOLE	
A/S 5010	0A-1196-0001
SYSTEM RISER #	N/A
DISPLAY F ASSY DWG	
SYSTEM VOLTAGE	120 VAC
HIGH LEG (AMPS)	3.4
MAXIMUM WATTS	400
SPORT INSERT #	LL-2483
OPERATING CODE #	DAKTENNIS

WITH 3/4" TNMCs

SYSTEM OPERATION REQUIREMENTS	
SYSTEM CONTROL CONSOLE	
A/S 5010	0A-1196-0001
SYSTEM RISER #	NA
DISPLAY F ASSY DWG	
SYSTEM VOLTAGE	120 VAC
HIGH LEG (AMPS)	5
MAXIMUM WATTS	600
SPORT INSERT #	LL-2483
OPERATING CODE #	DAKTENNIS

WITH 1" TNMCs

SYSTEM OPERATION REQUIREMENTS	
SYSTEM CONTROL CONSOLE	
A/S 5010	0A-1196-0001
SYSTEM RISER #	NA
DISPLAY F ASSY DWG	
SYSTEM VOLTAGE	120 VAC
HIGH LEG (AMPS)	6.7
MAXIMUM WATTS	800
SPORT INSERT #	LL-2483
OPERATING CODE #	DAKTENNIS

ADDRESS TABLE:

DRIVER	A1	A2	A3	A4	A5	A6
DRIVER A1	11	0	0	0	0	1
DRIVER A2	12	0	0	0	0	1
DRIVER A3	13	0	0	0	0	1
DRIVER A4	14	0	0	0	0	1
DRIVER A5	15	0	0	0	0	1
DRIVER A6	16	0	0	0	0	1

ADDRESS TABLE:

TOP (CT#1)	221	222	223	224	225	226
TOP (CT#1)	221	0	1	0	0	0
BOTTOM (CT#1)	221	0	0	0	0	1
TOP (CT#2)	222	0	1	0	0	0
BOTTOM (CT#2)	222	0	0	0	0	1
TOP (CT#3)	223	0	1	0	0	0
BOTTOM (CT#3)	223	0	0	0	0	1

ADDRESS TABLE:

TOP (CT#4)	224	225	226
TOP (CT#4)	224	0	1
BOTTOM (CT#4)	224	0	0
TOP (CT#5)	225	0	1
BOTTOM (CT#5)	225	0	0
TOP (CT#6)	226	0	1
BOTTOM (CT#6)	226	0	0

FOR TNMC OPTION
CABLES FOUND IN FINAL ASSY.

COURT 1	0A-1164-0260
COURT 2	0A-1164-0261
COURT 3	0A-1164-0262
COURT 4	0A-1164-0263
COURT 5	0A-1164-0264
COURT 6	0A-1164-0265

NOTE: NOT ALL DISPLAYS GET TNMC OPTION.
LOAD HARNESSSES EITHER WAY.

FOR TESTING PURPOSES

- USE THE ALLSPORT 5000, WITH INSERT LL-2483, AND CODE 229.
- TEST USING STANDARD SCORBOARD TESTING PROCEDURES.
- WHEN TESTING IS COMPLETE INSTALL CORRECT ADDRESS PULGS AND HARNESSSES.

THE CONCEPTS EXPRESSED AND DETAILS SHOWN ON THIS DRAWING ARE CONFIDENTIAL AND PROPRIETARY. DO NOT REPRODUCE BY ANY MEANS, INCLUDING ELECTRONICALLY WITHOUT THE EXPRESSED WRITTEN CONSENT OF DAKTRONICS, INC. COPYRIGHT 2006 DAKTRONICS, INC.

DAKTRONICS, INC. BROOKINGS, SD 57006

02	12 FEB 09	ADDED CABLE CHART FOR TNMC HARNESS	MRH	PROJ: INDOOR TENNIS
01	26 OCT 07	REVISED TEST CODE	KB	TITLE: SCHEMATIC- TN-25XX TWO COURT- HORIZONTAL SECTION
REV.	DATE	DESCRIPTION	BY	DES. BY: DDINING DATE: 13 AUG 06
02				APPR. BY: MMILLER SCALE: NONE 1164-R03B-282123

Appendix D: Additional Reference Drawings

<i>Drawing Title</i>	<i>Drawing Number</i>
Signal Connection, Installation.....	A-28124
Segmentation, 7 Segment Bar Digit	A-38532
16 Column LED Driver II Specifications.....	A-126174
System Riser: Tennis; Single-Court w/ TNMC, AS 5000.....	A-177098
Base Station: Indoor Installation	A-227465
System Riser; Tennis; Indoor Multi-Court, DakTennis, CG	B-231298
System Riser; Tennis; Multi-Court, RC-100 Direct	B-233254
System Riser: Tennis; Indoor/Outdoor Single Court, RC-100	A-252412
Address Details; Indoor Tennis Scoreboards	A-1054354

DISPLAY LOCATION

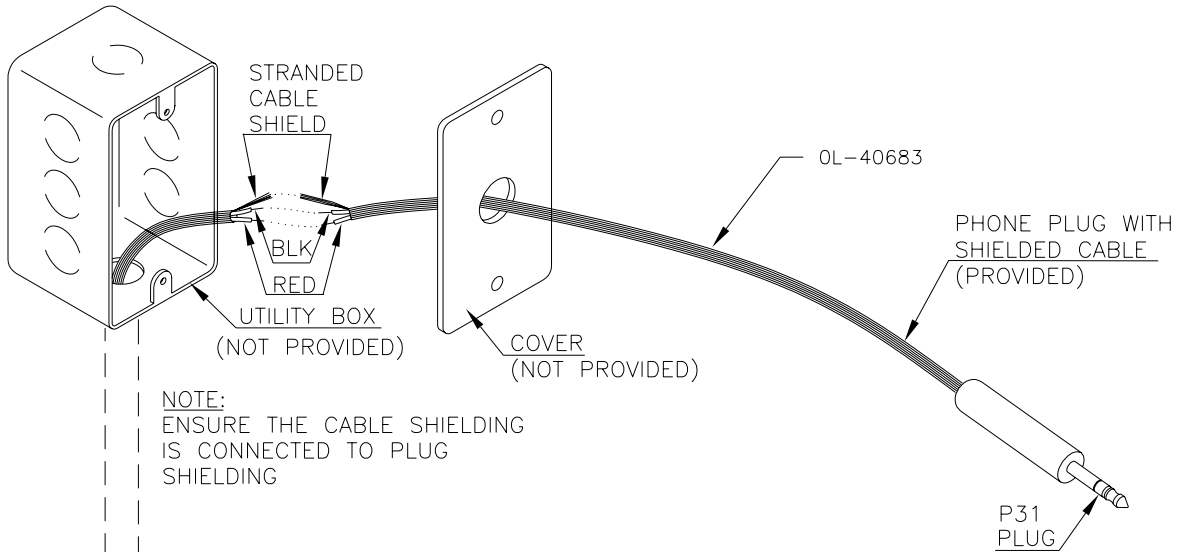

NOTE:
ENSURE THE CABLE SHIELDING
IS CONNECTED TO PLUG
SHIELDING

PROCEDURE

1. ROUTE CONDUIT BETWEEN CONTROL AND DISPLAY LOCATIONS.
2. MOUNT BOXES.
3. PULL CABLE THROUGH CONDUIT.
4. CONNECT CABLE TO J31 AND P31

J31: USE CONNECTORS PROVIDED.
INSERT WIRES INTO CONNECTOR
AND SQUEEZE CONTACT DOWN
WITH PLIERS. SNAP PLASTIC
COVER SHUT.

P31: CONNECT WIRES TO CABLE AS
FOLLOWS:

- J31 RED TO P31 RED (+)
- J31 BLK TO P31 BLK (-)
- J31 SHIELD TO P31 SHIELD

NOTE!!

DO NOT CONNECT
CABLE SHIELD AT
CONTROL CONSOLE END

SHIELDED CABLE
IN CONDUIT
(NOT PROVIDED)

TO MAIN BOARD

TO AUX BOARD

J-BOX
(PROVIDED)

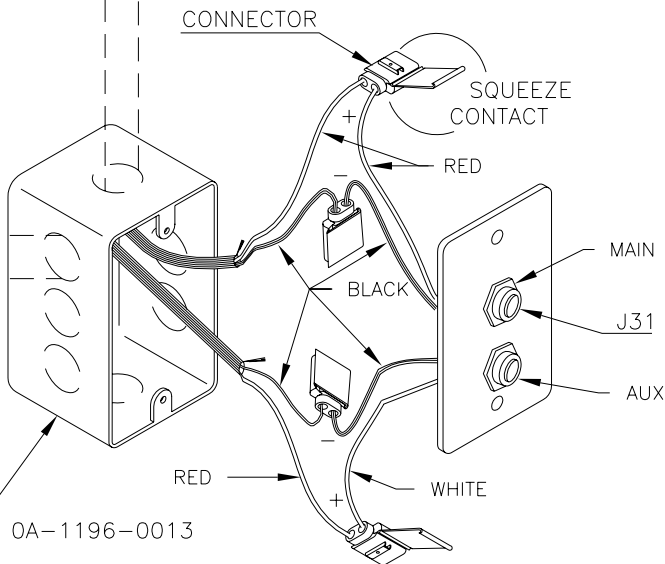

CONTROL LOCATION

05	30 JUL 03	BOLD FACED GROUNDING NOTE	TLH	
04	17 JUN 03	CHANGED GROUNDING PROCEDURES	JJC	MWM
3	17 JAN 02	ADDED AUX TO J-BOX	JJS	
2	25 MAR 92	CHANGED WHITE TO RED	JTC	
1	05 NOV 91	REDREW ON A-SIZE ON ACAD.	JLH	
REV.	DATE	DESCRIPTION	BY	APPR.

DAKTRONICS, INC. BROOKINGS, SD 57006			
PROJ: BASKETBALL			
TITLE: SIGNAL CONNECTION; INSTALLATION			
DES. BY: AVB		DRAWN BY: MHART	
		DATE: 15SEP86	
REVISION	APPR. BY: AVB	1009-R10A-28124	
05	SCALE: NONE		

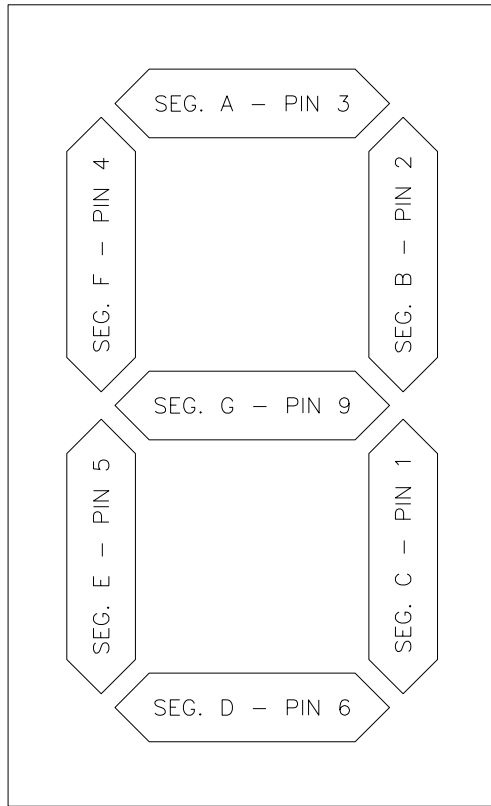

7 SEGMENT BAR DIGIT
FRONT VIEW

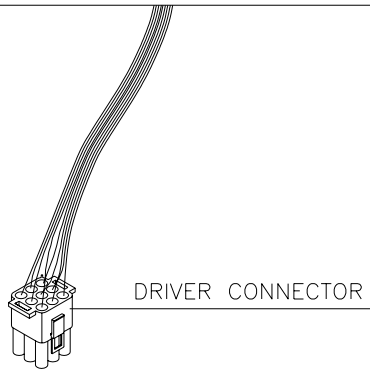

COLOR CODE		
PIN NO.	WIRE COLOR	DRIVER SEGMENT
1	ORN	C
2	RED	B
3	BRN	A
4	BLU	F
5	PNK	E
6	TAN	D
7	BLK	COM.
8	GRY	H
9	VIO	G

CONNECTOR PIN NUMBERING
NOTE SPLINE NEAR NO. 1

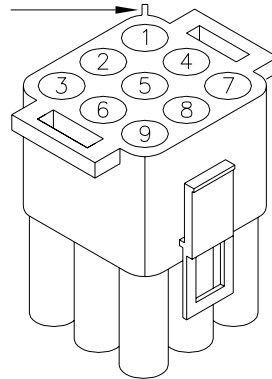

NOTE: "H" SEGMENT, GRAY WIRE IS NOT USED ON 7 SEGMENT BAR DIGIT.

THE CONCEPTS EXPRESSED AND DETAILS SHOWN ON THIS DRAWING ARE CONFIDENTIAL AND PROPRIETARY. DO NOT REPRODUCE BY ANY MEANS, INCLUDING ELECTRONICALLY WITHOUT THE EXPRESSED WRITTEN CONSENT OF DAKTRONICS, INC. COPYRIGHT 2003 DAKTRONICS, INC.

DAKTRONICS, INC. BROOKINGS, SD 57006

PROJ: BASKETBALL

TITLE: SEGMENTATION, 7 SEGMENT BAR DIGIT

DES. BY: DRAWN BY: HEIDERSCHIEDT DATE: 5 JUN 89

REVISION APPR. BY: AVB
02 SCALE: 1=4

1009-R04A-38532

REV.	DATE	DESCRIPTION	BY	APPR.
2	30 APR 97	ADDED SEGMENT DESIGNATIONS TO DIGIT FIGURE.	AVB	AVB
1	2 JAN 92	CHANGED FROM B-SIZE TO A-SIZE DWG.	C FICK	

OP-1150-0126 UNCOATED OR OP-1150-0127 COATED
16 COLUMN LED DRIVER II

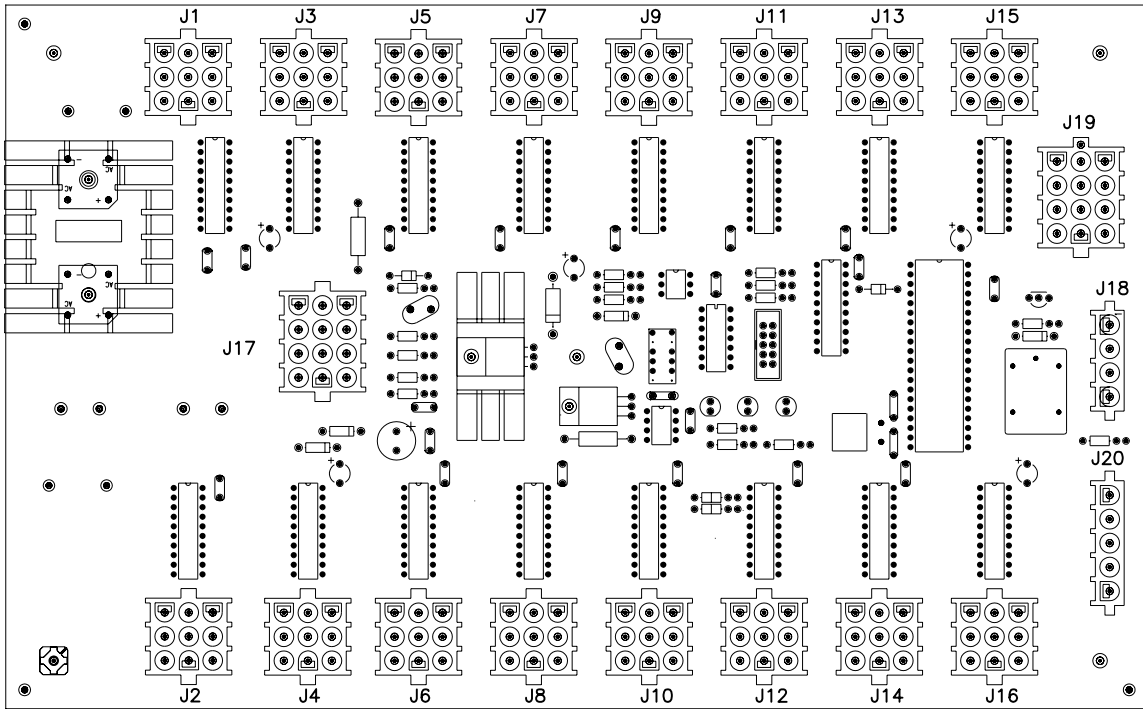

J17 MAIN	
PIN	FUNCTION
1	SIG-P
2	SIG-N
3	SIG2-P
4	CLOUT-P
5	CLOUT-N
6	16VAC-N
7	GND-N
8	EARTH-N
9	16VAC-P
10	GND-N
11	+VDD-P
12	+VBB-P

J1-16 DIGIT	
PIN	FUNCTION
1	SEGC-N
2	SEGB-N
3	SEGA-N
4	SEGF-N
5	SEGE-N
6	SEGD-N
7	+VCC-P
8	SEGH-N
9	SEGG-N

J19 ADDRESS	
PIN	FUNCTION
1	GND-N
2	ADD0-N
3	ADD1-N
4	GND-N
5	ADD2-N
6	ADD3-N
7	GND-N
8	ADD4-N
9	ADD5-N
10	GND-N
11	ADD6-N
12	ADD7-N

J18 RELAY	
PIN	FUNCTION
1	HORNOUT-N
2	AUXOUT-N
3	120SW-P
4	120SW-N

J20 PROTOCOL	
PIN	FUNCTION
1	GND-N
2	PRO-N
3	PR1-N
4	PR2-N
5	TOD-N

NOTE

-WITH NO ADDRESS PINS SELECTED THE DRIVER WILL DEFAULT TO A/S 4000 PROTOCOL

-GREEN LED INDICATES THE DRIVER HAS POWER

-RED LED WILL BE ON OR BLINKING WHEN THE DRIVER IS RECEIVING SIGNAL

-AMBER LED INDICATES LED DRIVER STATUS, LED WILL BE BLINKING TO INDICATE THAT THE DRIVER IS RUNNING, IF THE LED IS OFF OR ON SOLID ALL OF THE TIME, THEN THE DRIVERS CPU IS NOT FUNCTIONING AND MAY NEED TO BE RESET OR REPLACED.

-REFER TO DRAWINGS A-115078 & A-115079 FOR J19 ADDRESS SETTINGS FOR THIS DRIVER.

-REFER TO DRAWING A-115081 FOR J20 PROTOCOL SETTINGS FOR THIS DRIVER.

-REDRIVE CIRCUIT IS PROCESSOR REFRESHED (REFER TO DWG A-128429 FOR FURTHER INFORMATION ON THE CURRENT LOOP REDRIVE CIRCUIT SPECIFICATIONS)

DAKTRONICS, INC. BROOKINGS, SD 57006

PROJ:

TITLE: 16 COLUMN LED DRIVER II SPECIFICATIONS

DES. BY: EB

DRAWN BY: EBRAVEK

DATE: 11 JAN 00

REVISION

APPR. BY:

01

SCALE: 1=2

1150-R07A-126174

REV.	DATE	DESCRIPTION	BY	APPR.
01	2 OCT 00	UPDATED NOTES SECTION	NSW	

WIRE COMMUNICATION
REAR VIEW

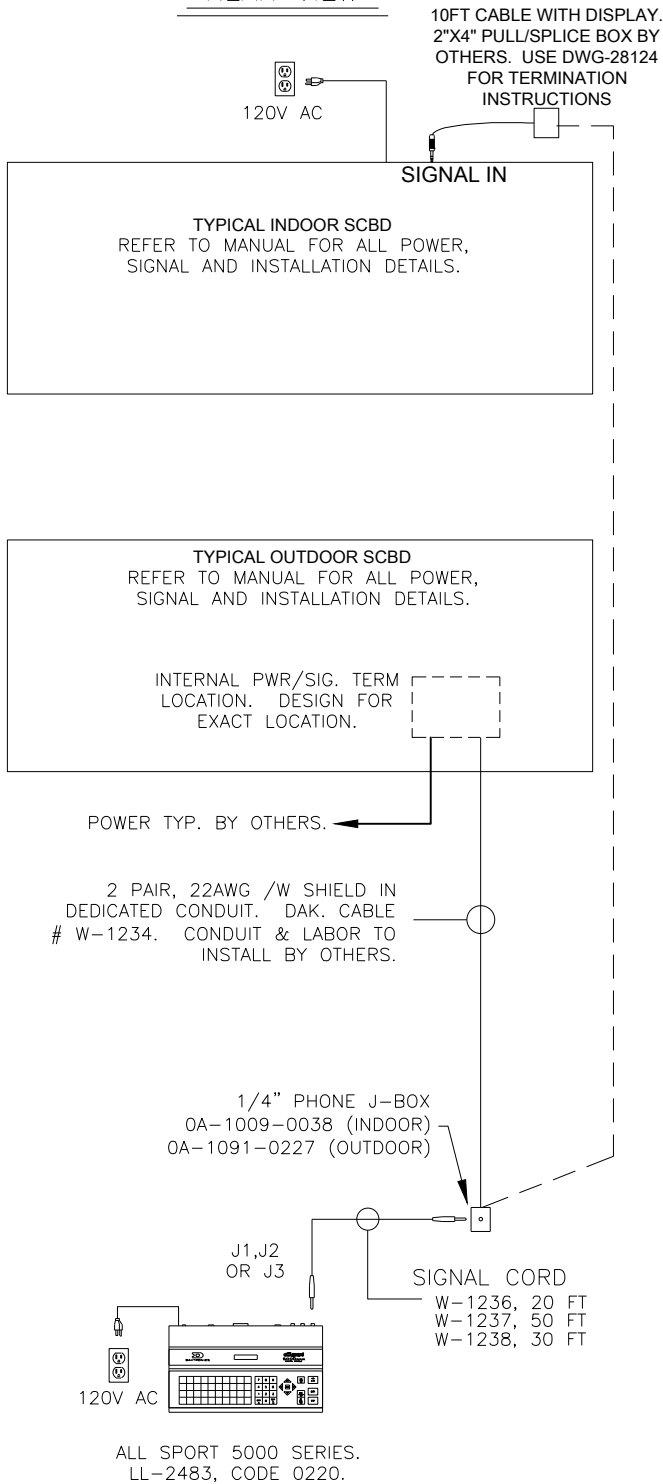

RADIO COMMUNICATION
REAR VIEW

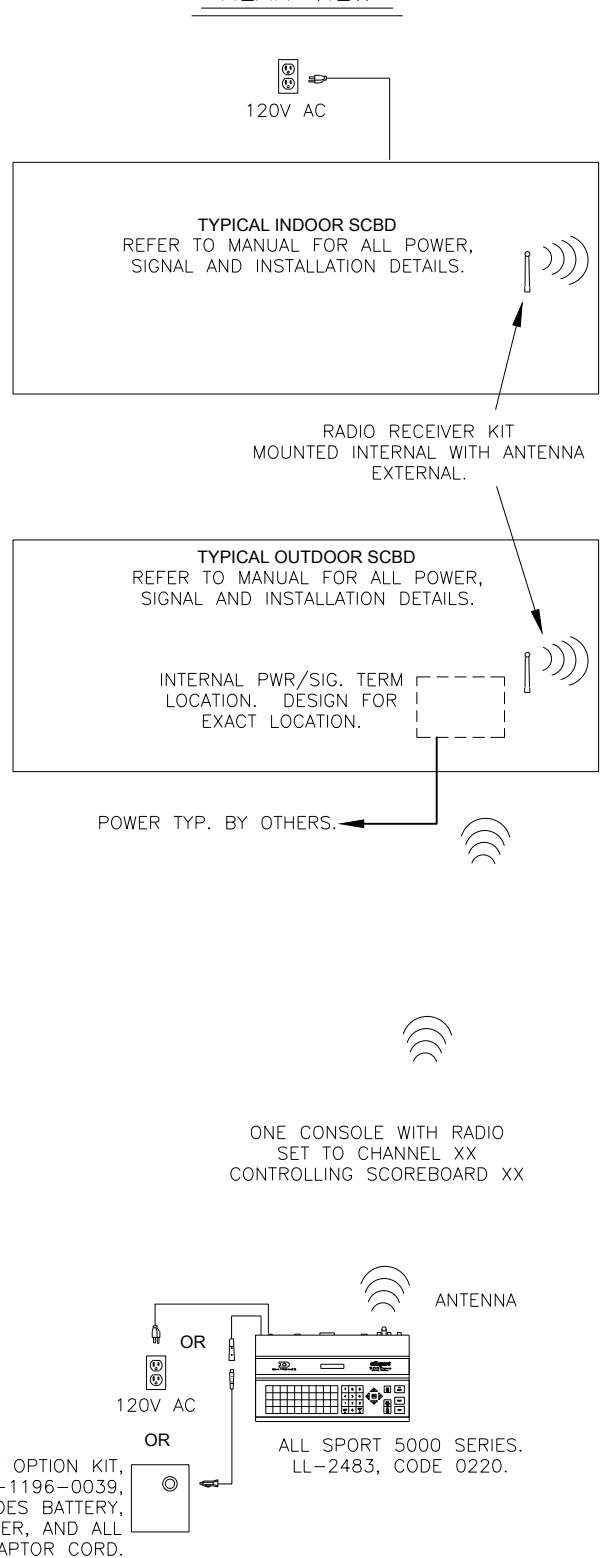

<p>DAKTRONICS, INC. BROOKINGS, SD 57006</p>	<p>THE CONCEPTS EXPRESSED AND DETAILS SHOWN ON THIS DRAWING ARE CONFIDENTIAL AND PROPRIETARY. DO NOT REPRODUCE BY ANY MEANS WITHOUT THE EXPRESSED WRITTEN CONSENT OF DAKTRONICS, INC. COPYRIGHT 2012 DAKTRONICS, INC.</p>		
	<p>DO NOT SCALE DRAWING</p>		
<p>PROJ: TENNIS SCOREBOARDS</p>			
<p>TITLE: SYSTEM RISER; TENNIS; SINGLE COURT W/ TNMC, AS 5000</p>			
<p>DESIGN: MMILLER</p>		<p>DRAWN: MMILLER</p>	
<p>SCALE: NONE</p>			
<p>SHEET</p>	<p>REV</p>	<p>JOB NO:</p>	<p>FUNC-TYPE-SIZE</p>
<p>03</p>	<p>P 1164</p>	<p>R - 01 - A</p>	<p>177098</p>

REV 03	DATE: 26 SEP 12	UPDATED BOARD AND TITLE BLOCK REMOVED PART NUMBER FROM THE RADIO RECIEVER TAG SO WE CAN USE MORE GENERATIONS	BY: MWM
REV 02	DATE: 23AUG05	REMOVED ALL SPORT 1600 SERIES CONTOLLER CHANGED NAME OF DRAWING	BY: TAJ
REV 01	DATE: 28 MAY 03	SEPERATED THE WIRE AND THE RADIO ILLUSTRATIONS.	BY: MWM

TOP VIEW

STEP 1.2 CHART

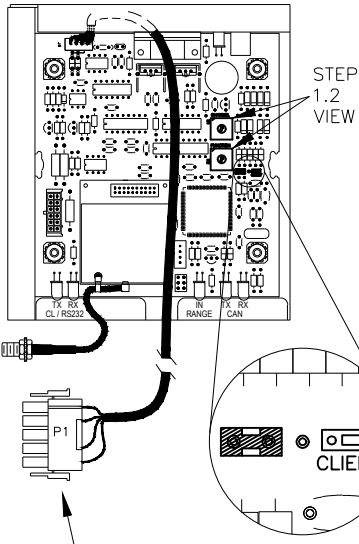

FUNCTION SETTING	FUNCTION (SERVER MODE)
0	DEFAULT FUNCTION (LAST POWER UP FUNCTION)
1	CAN HANDHELD JUDGES CONSOLE
2	ALL SPORT SCBD CONTROLLER - GEN I
3	DATA TIME MASTER DISPLAY CONTROLLER
5	ALL SPORT SCBD CONTROLLER - GEN II
F	RESET MEMORY/TEST
4, 6-E	RESERVED

STEP 1.1

USING A NUT DRIVER REMOVE THE 2 NUTS ON THE TOP OF THE RADIO ENCLOSURE. REMOVE THE COVER FROM THE ENCLOSURE.

STEP 1.2

USING A SMALL FLAT HEAD SCREW DRIVER OR YOUR FINGERS CHANGE THE SWITCHES TO THE DESIRED CHANNEL AND FUNCTION NUMBER. (REFER TO STEP 1.2 VIEW AND CHART FOR CHANNEL SELECTION.)

STEP 1.3

NOTE THE CHANNEL NUMBER SET FOR THIS UNIT AND REATTACH THE COVER ON THE ENCLOSURE USING THE NUTS REMOVED IN STEP 1.1. BE SURE TO REINSTALL THE ANTENNA CABLE AND COVER AS THEY WERE.

STEP 1.4

BASE STATION IS SET IN FACTORY FOR SERVER MODE. FOR CLIENT MODE, SET JUMPERS TO RIGHT MOST POSITION.

STEP 2.1

FIND A LOCATION ON THE INSIDE OF THE POWER/SIGNAL ACCESS DOOR, THAT THE BASE STATION ENCLOSURE, ONCE MOUNTED, WILL NOT INTERFERE WITH THE CLOSING OF THE DOOR. (REFER TO YOUR SCOREBOARDS INSTALLATION MANUAL TO DETERMINE THE LOCATION OF THE POWER/SIGNAL ACCESS DOOR.)

STEP 2.2

CHECK FOR A PREDRILLED 9/32" HOLE IN THE POWER/SIGNAL ACCESS DOOR. IF THERE IS NO HOLE, DRILL A 9/32" HOLE THROUGH THE FACE OF THE DOOR. AS SHOWN BELOW.

STEP 2.3

BASE STATION ENCLOSURE INCLUDES FOUR, 5" VELCRO STRIPS. INSTALL BY REMOVING THE BACKING OFF THE VELCRO TO EXPOSE STICKY ADHESIVE. ATTACH ON THE SCOREBOARD POWER/SIGNAL ACCESS DOOR DIRECTLY ABOVE THE HOLE YOU DRILLED EARLIER.

STEP 2.4

FEED THE ANTENNA CABLE, FROM THE BASE STATION, THROUGH THE 9/32" HOLE. ATTACH THE ANTENNA CABLE TO THE FACE OF THE SCOREBOARD WITH THE SUPPLIED LOCK WASHER AND NUT.

STEP 2.5

ATTACH THE PROVIDED ANTENNA TO THE PREVIOUSLY MOUNTED ANTENNA CABLE AND TIGHTEN. BE SURE TO HAVE THE ANTENNA POINTING UP AS SHOWN BELOW.

STEP 2.6

PLUG THE 5 PIN MALE PLUG FROM THE BASE STATION INTO THE MATING 5 PIN JACK (J45) ON THE DRIVER PANEL AS SHOWN TO THE LEFT.

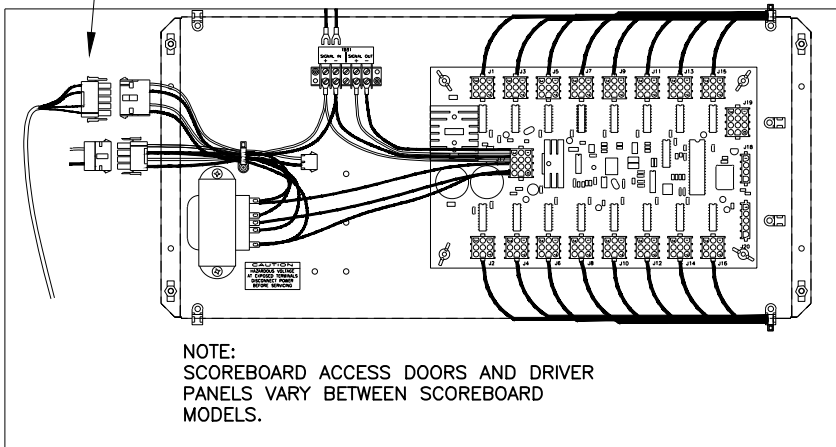

NOTE:

BE SURE TO CHOOSE A LOCATION ON THE INSIDE OF THE POWER/SIGNAL ENTRANCE DOOR THAT WHEN THE BASE STATION IS MOUNTED INTERNALLY WILL NOT INTERFERE WITH ANYTHING.

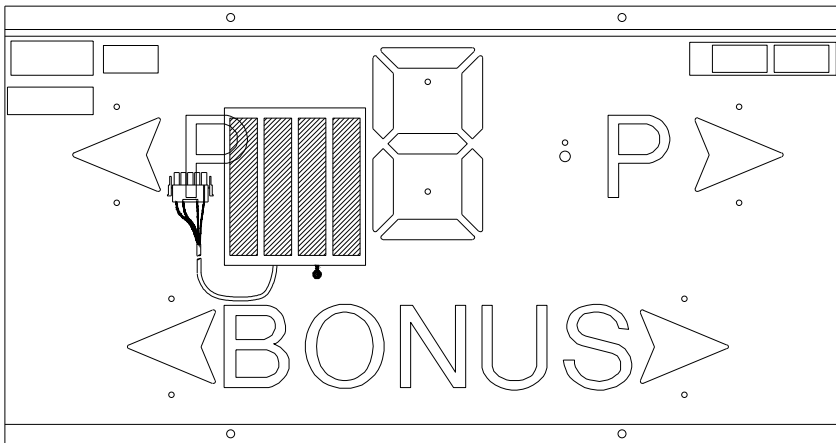
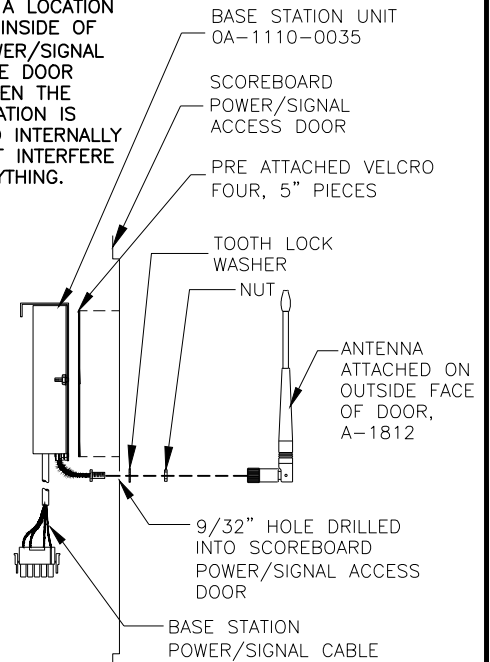

DAKTRONICS, INC. BROOKINGS, SD 57006 DO NOT SCALE DRAWING		THE CONCEPTS EXPRESSED AND DETAILS SHOWN ON THIS DRAWING ARE CONFIDENTIAL AND PROPRIETARY. DO NOT REPRODUCE BY ANY MEANS WITHOUT THE EXPRESSED WRITTEN CONSENT OF DAKTRONICS, INC. COPYRIGHT 2011 DAKTRONICS, INC.		
		PROJ: RC-100 TITLE: BASE STATION: INDOOR INSTALLATION	DESIGN: _____ SCALE: 1 = 7	DRAWN: DULSCHM
03 24 AUG 11 UPDATED FUNCTION CHART AND TITLE BLOCK JJL	02 18 JUN 08 ADDED STEP 1.4 AND DETAIL AMG	01 02 MAR 05 UPDATED DRAWING FOR NEW REV METAL PARTS DJU	SHEET: _____ REV: 03 JOB NO: 1110 FUNC-TYPE-SIZE: E-07-A	227465

INDOOR SCOREBOARD LAYOUT
REFER TO MANUAL FOR ALL POWER, SIGNAL AND
INSTALLATION DETAILS.

REAR VIEW

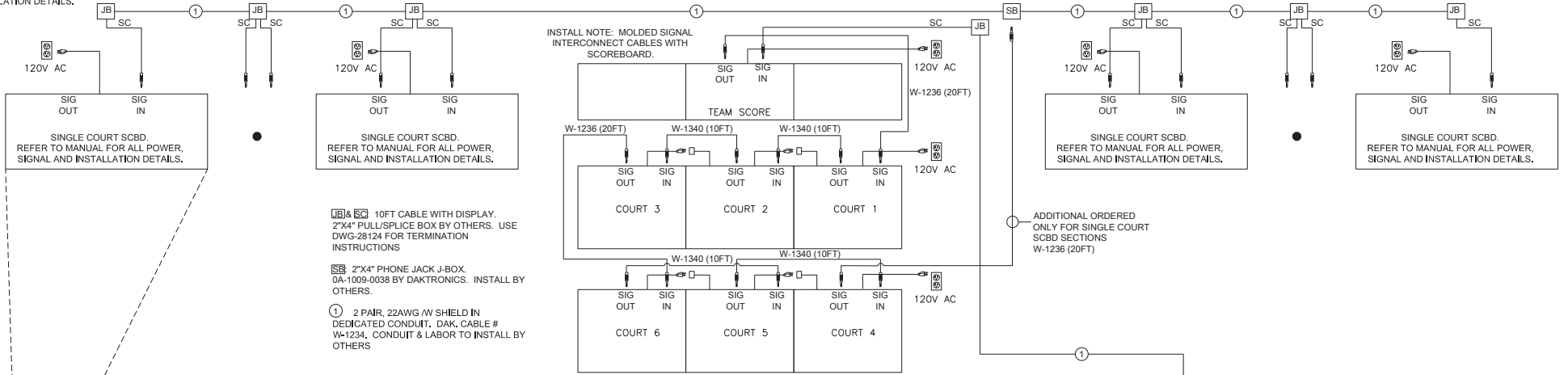

W-1236 10FT CABLE WITH DISPLAY.
2"x4" PULL/SPLICE BOX BY OTHERS. USE
DWG-28124 FOR TERMINATION
INSTRUCTIONS

SB 2"x4" PHONE JACK J-BOX.
0A-1009-0038 BY DAKTRONICS. INSTALL BY
OTHERS.

1 2 PAIR, 22AWG W/ SHIELD IN
DEDICATED CONDUIT. DAK. CABLE #
W-1234. CONDUIT & LABOR TO INSTALL BY
OTHERS

ONLY FOR SINGLE
COURT SCBDS

ADDITIONAL ORDERED
ONLY FOR SINGLE COURT
SCBD SECTIONS
W-1236 (20FT)

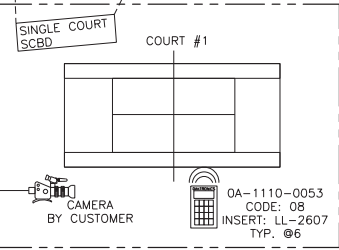

NOTE:
THE 6 RC-100 CONTROLLERS USE CHANNELS
1-15. HOWEVER, THE BASE STATION AND HAND
HELD CONTROLLERS MUST BE OPERATING ON THE
SAME CHANNEL.

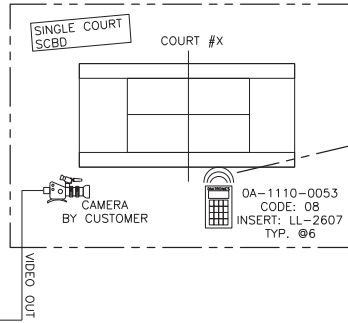

DAKTENNIS CONTROL LOCATION
CLEAR LINE OF SIGHT REQUIRED.

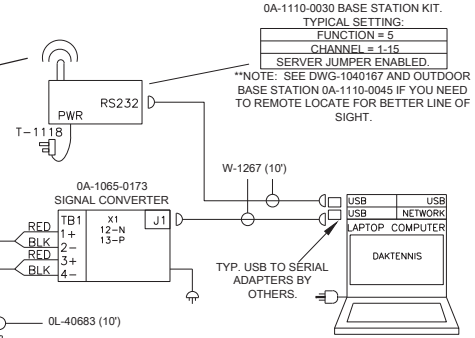

0A-1110-0030 BASE STATION KIT.
TYPICAL SETTING:
FUNCTION = 5
CHANNEL = 1-15
SERVER JUMPER ENABLED.

*NOTE: SEE DWG-1040167 AND OUTDOOR
BASE STATION 0A-1110-0045 IF YOU NEED
TO REMOTE LOCATE FOR BETTER LINE OF
SIGHT.

PRODUCTION LOCATION
ALLSPORT CG SETUP

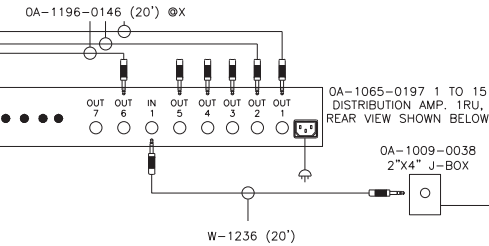
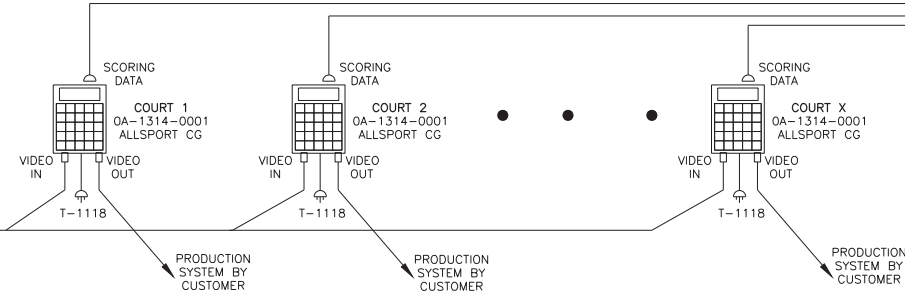

0A-1009-0038
2"x4" J-BOX

W-1077, 1 PAIR, 22AWG MINIMUM IN
CONDUIT WHERE REQUIRED.
1000FT MAX. DISTANCE

REV 05	DATE: 02 DEC 13	MOVED POWER AND SIGNAL CABLES TO THE MIDDLE SECTION OF THE TOP TEAM SCORE SCOREBOARD	BY: ACB
REV 04	DATE: 08 OCT 12	UPDATED BOARD TO B SIZED. ADDED DETAILS TO SHOW INDOOR SCOREBOARD LAYOUT	BY: MWM
REV 03	DATE: 27 APR 12	UPDATED RC-100 HANDHELD PARTNUMBER UPDATED BOARDER AND TITLE BLOCK	BY: JFL

DAKTRONICS, INC. BROOKINGS, SD 57006 DO NOT SCALE DRAWING		THE CONCEPTS EXPRESSED AND DETAILS SHOWN ON THIS DRAWING ARE CONFIDENTIAL AND PROPRIETARY. DO NOT REPRODUCE BY ANY MEANS WITHOUT THE EXPRESSED WRITTEN CONSENT OF DAKTRONICS, INC. COPYRIGHT 2012 DAKTRONICS, INC.
PROJ: TENNIS SCOREBOARDS TITLE: SYSTEM RISER; TENNIS; INDOOR MULTI-COURT, DAKTENNIS, CG		
DESIGN:	DRAWN: RTAGTOW	DATE: 11 JAN 05
SCALE: NONE	REV: 05	JOB NO: P1164
SHEET	REV	JOB NO.
		FLUNC-TYPE-SIZE

INDOOR SCOREBOARD LAYOUT
REFER TO MANUAL FOR ALL POWER, SIGNAL AND INSTALLATION DETAILS.

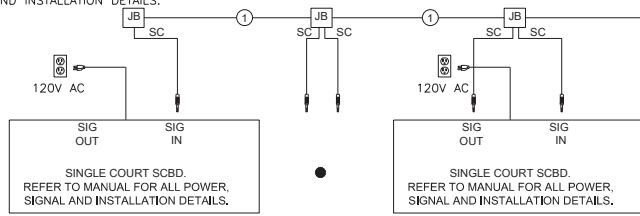

JB & SC 10FT CABLE WITH DISPLAY. 2"x4" PULL/SPLICE BOX BY OTHERS. USE DWG-28124 FOR TERMINATION INSTRUCTIONS

SB 2"x4" PHONE JACK J-BOX. 0A-1009-0038 BY DAKTRONICS. INSTALL BY OTHERS.

① 2 PAIR, 22AWG W/ SHIELD IN DEDICATED CONDUIT. DAK. CABLE # W-1234. CONDUIT & LABOR TO INSTALL BY OTHERS

REAR VIEW

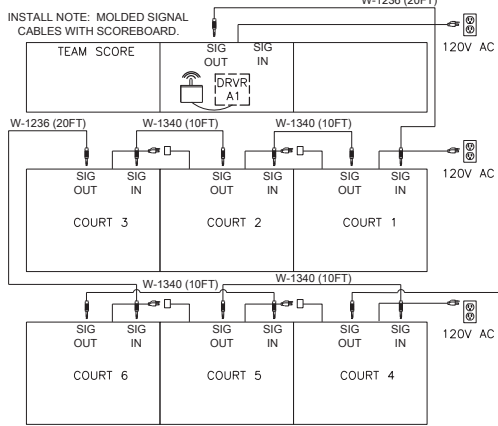

ADD ONLY FOR SINGLE COURT SCBDS

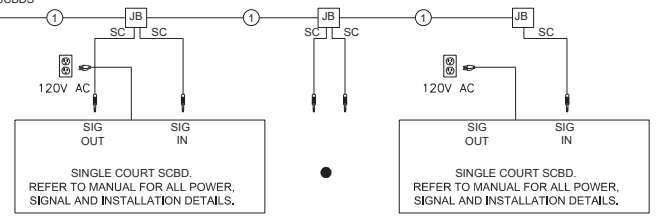

ADD ONLY FOR SINGLE COURT SCBD SECTIONS W-1236 (20FT)

OUTDOOR SCOREBOARD LAYOUT

REFER TO MANUAL FOR ALL POWER, SIGNAL AND INSTALLATION DETAILS.

REAR VIEW

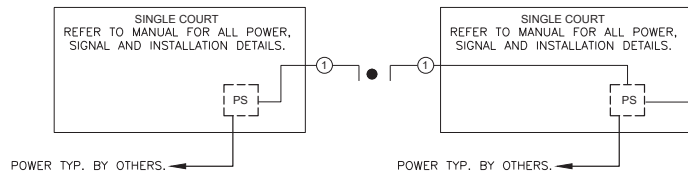

PS INTERNAL PWR/SIG. TERM LOCATION. EXACTLY LOCATION IS DETERMINED BY MODEL PURCHASED.

① 2 PAIR, 22AWG W/ SHIELD IN DEDICATED CONDUIT. DAK. CABLE # W-1234. CONDUIT & LABOR TO INSTALL BY OTHERS

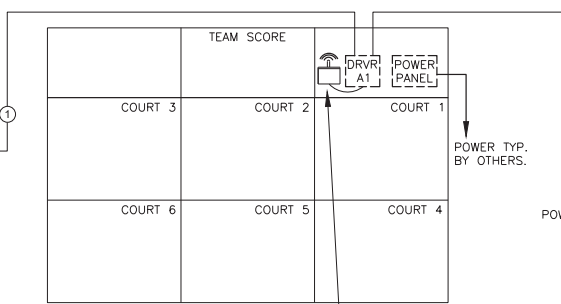

0A-1110-0035
FUNCTION SETTING = 5

NOTE: RC-100 SCOREBOARD RECEIVER BASE STATION IS TYPICALLY LOCATED BEHIND THE FRONT ACCESS LOCATION OF DISPLAY FOR BOTH INDOOR AND OUTDOOR.

RC-100 AT EACH COURT. COMMUNICATION TO MAIN MULTI-COURT RECEIVER.



0A-1110-0053
CODE: 08
INSERT: LL-2607
TYP. ⑥6

NOTE: THE 6 RC-100 CONTROLLERS USE CHANNELS 1-15. HOWEVER, THE BASE STATION AND HAND HELD CONTROLLERS MUST BE OPERATING ON THE SAME CHANNEL.

FUNCTION NUMBER	DESCRIPTION
0	DEFAULT FUNCTION (LAST POWER UP FUNCTION) CAN HAND HELD (JUDGES) CONSOLE
2	BASEBALL/TENNIS SCOREBOARD CONTROLLER GEN I (ALLSPORT)
3	DATETIME/DATAMASTER DISPLAY CONTROL
5	BASEBALL/TENNIS SCOREBOARD CONTROLLER GEN II (ALLSPORT)

REV	DATE	DESCRIPTION	BY
05	02 DEC 13	MOVED POWER AND SIGNAL CABLES TO THE MIDDLE SECTION OF THE TOP TEAM SCORE SCOREBOARD	ACB
04	08 OCT 12	UPDATE BOARD TO B - SIZE. SHOW INDOOR AND OUTDOOR DETAIL UPDATES	MWM
03	27 APR 12	UPDATED RC-100 HANDHELD PART NUMBER UPDATED BOARDER AND TITLE BLOCK	JFL
02	15 JAN 07	ADDED FUNCTION 5 GEN II	JRA
01	23AUG05	ADDED 6 COURT SCORING DIAGRAM CHANGED NAME OF DRAWING	TJL

DAKTRONICS, INC.
BROOKINGS, SD 57006

THE CONCEPTS EXPRESSED AND DETAILS SHOWN ON THIS DRAWING ARE CONFIDENTIAL AND PROPRIETARY. DO NOT REPRODUCE BY ANY MEANS WITHOUT THE EXPRESSED WRITTEN CONSENT OF DAKTRONICS, INC. COPYRIGHT 2012 DAKTRONICS, INC.

DO NOT SCALE DRAWING

PROJ: TENNIS SCOREBOARDS
TITLE: SYSTEM RISER; TENNIS; MULTI-COURT, RC-100 DIRECT
DESIGN: DRAWN: RTAGTOW DATE: 02 FEB 05

SCALE: NONE

SHEET	REV	JOB NO.	FUNC-TYPE-SIZE
	05	P1164	R-01-B

233254

NOTE:
 SAMPLE SCOREBOARD MODEL SHOWN. SEE
 SPECIFICATION MATERIAL ON MODEL PURCHASED.

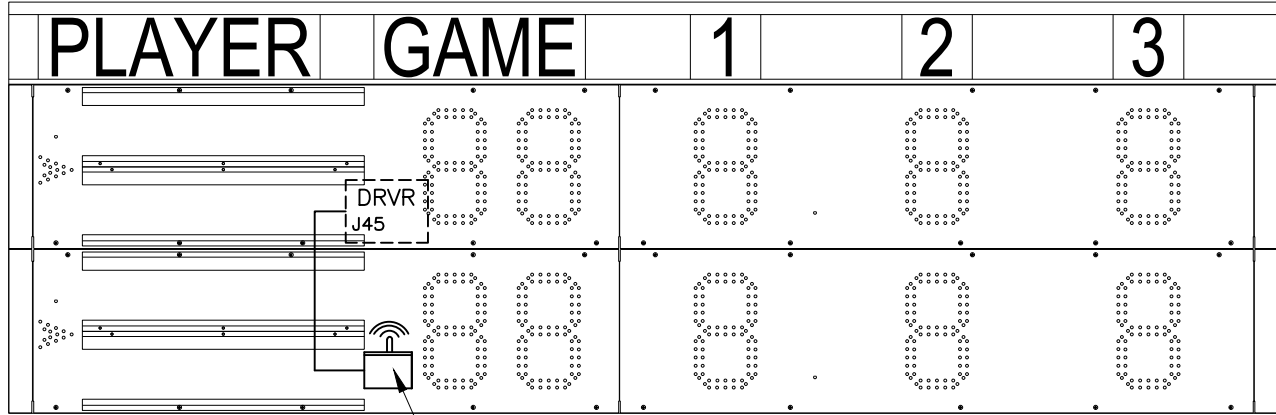

0A-1110-0035
 FUNCTION SETTING = 5

NOTE: RC-100 SCOREBOARD RECEIVER
 BASE STATION IS LOCATED BEHIND THE
 FRONT ACCESS PANEL OF DISPLAY.

NOTE:
 THE WIRELESS BASE STATION COMES PRE-SET TO
 CHANNEL 1. HOWEVER, CHANNELS 1-15 CAN BE
 USED.

FUNCTION TABLE

FUNCTION NUMBER	DESCRIPTION
0	DEFAULT FUNCTION (LAST POWER UP FUNCTION)
1	CAN HAND HELD (JUDGES) CONSOLE
2	BASEBALL/TENNIS SCOREBOARD CONTROLLER GEN I (ALLSPORT)
3	DATETIME/DATAMASTER DISPLAY CONTROL
5	BASEBALL/TENNIS SCOREBOARD CONTROLLER GEN II (ALLSPORT)

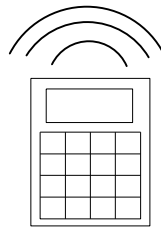

0A-1110-0053
 INSERT: LL-2607 (TENNIS) CODE 08

 DAKTRONICS, INC. BROOKINGS, SD 57006	THE CONCEPTS EXPRESSED AND DETAILS SHOWN ON THIS DRAWING ARE CONFIDENTIAL AND PROPRIETARY. DO NOT REPRODUCE BY ANY MEANS WITHOUT THE EXPRESSED WRITTEN CONSENT OF DAKTRONICS, INC. COPYRIGHT 2012 DAKTRONICS, INC.	
	DO NOT SCALE DRAWING	
PROJ: TENNIS SCOREBOARDS TITLE: SYSTEM RISER; TENNIS; INDOOR/OUTDOOR SINGLE COURT, RC-100		
DESIGN:	DRAWN: TJOHNSON	DATE: 29AUG05
SCALE: NONE		
SHEET	REV: 02 JOB NO: P1164	FUNC-TYPE-SIZE: R-01-A
		252412

REV 02	DATE: 27 APR 12	UPDATED RC-100 HANDHELD PART NUMBER UPDATED BOARDER AND TITLE BLOCK	BY: JFL
01	22 OCT 09	UPDATED FUNCTION SETTING AND TABLE. ALSO ADDED NOTE ABOUT SCOREBOARD.	EJS

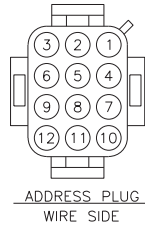

ADDRESS PLUG
WIRE SIDE

WIRING DIAGRAM

DRIVER ADDRESS PLUG
WITH ALL WIRES
CONNECTED

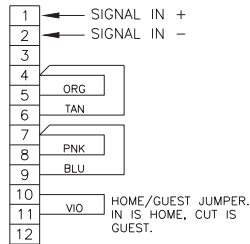

WIRING DIAGRAM

TNMC ADDRESS PLUG
WITH ALL WIRES
CONNECTED

KEY: 0 = PIN N/C
1 = PIN CONNECTED

		PIN 12	PIN 11	PIN 9	PIN 8	PIN 6	PIN 5	PIN 3	PIN 2
(DRIVER) COURT 1	11	0	0	0	0	0	1	1	0
COURT 2	12	0	0	0	0	1	1	0	0
COURT 3	13	0	0	0	0	1	1	0	1
COURT 4	14	0	0	0	0	1	1	1	0
COURT 5	15	0	0	0	0	1	1	1	1
COURT 6	16	0	0	0	1	0	0	0	0
COURT 7	17	0	0	0	1	0	0	0	1
COURT 8	18	0	0	0	1	0	0	1	0
COURT 9	29	0	0	0	1	1	1	0	1
COURT 10	30	0	0	0	1	1	1	1	0
COURT 11	31	0	0	0	1	1	1	1	1
COURT 12	32	0	0	1	0	0	0	0	0
COURT 13	33	0	0	1	0	0	0	0	1
COURT 14	34	0	0	1	0	0	0	1	0
COURT 15	35	0	0	1	0	0	0	1	1
COURT 16	36	0	0	1	0	0	1	0	0
COURT 17	37	0	0	1	0	0	1	0	1
COURT 18	38	0	0	1	0	0	1	1	0
DUAL 1 TEAM SCORE/TOD	20	0	0	0	1	0	1	0	0
DUAL 2 TEAM SCORE/TOD	21	0	0	0	1	0	1	0	1
DUAL 3 TEAM SCORE/TOD	23	0	0	0	1	0	1	1	0

NOTE: ADD 22 IS NOT USED, RESERVED FOR OTHER THINGS

		PIN 12	PIN 11	PIN 9	PIN 8	PIN 6	PIN 5	PIN 3	PIN 2
(TNMC) COURT 1	221	0	0	0	0	0	1	1	0
COURT 2	222	0	0	0	1	0	0	0	0
COURT 3	223	0	0	0	1	1	0	0	0
COURT 4	224	0	1	0	0	0	0	0	0
COURT 5	225	0	1	0	0	1	0	0	0
COURT 6	226	0	1	1	0	0	0	0	0
COURT 7	227	0	1	1	1	0	0	0	0
COURT 8	228	1	0	0	0	0	0	0	0
COURT 9	229	1	0	0	1	0	0	0	0
COURT 10	231	1	0	1	1	0	0	0	0
COURT 11	232	1	1	0	0	0	0	0	0
COURT 12	233	1	1	0	1	0	0	0	0
NOTE: COURTS ABOVE 13 DO NOT SUPPORT TNMCS									
DUAL 1 TEAM SCORE/TOD	230	1	0	1	0	0	0	0	0
DUAL 2 TEAM SCORE/TOD	234	1	1	1	0	0	0	0	0

SELECTS HOME (1)
OR GUEST (0)

NOTES

A SINGLE COURT SCOREBOARD, SOLD AS COURT 1 ONLY, SHOULD BE SET WITH ADDRESS 11 (DRIVER) AND 221 (TNMC) IN MANUFACTURING.

IF SEVERAL SINGLE COURT SCOREBOARDS ARE SOLD, THEY WILL NEED TO BE DESIGNATED COURT 1, 2, 3, ETC. THEN SET THE ADDRESSES FOR THE SCOREBOARDS TO MATCH THE COURT NUMBER, IN MANUFACTURING.

MULTI COURT SCOREBOARD MODELS, TN-2560 THRU TN-2563 ARE SEVERAL SINGLE COURT SECTIONS AND A TEAM SCORE/TOD SECTION. AGAIN, ALL THE SECTIONS WILL NEED TO BE DESIGNATED AND THEN SET THE ADDRESSES FOR THE SCOREBOARDS TO MATCH.

SINGLE COURT MODELS

MODEL	ADDRESS	VOLTAGE	VINYL CAPTIONS		TNMC PAIR 6" (3/4)		TNMC PAIR 8" (1)	
			WATTS	AMPS	WATTS	AMPS	WATTS	AMPS
TN-2501, 2502	A1 *11	120V	200	1.7	N/A	N/A	N/A	N/A
		240V		0.9				
TN-2503, 2504	A1 *11 TNMC *221	120V	200	1.7	300	2.5	1.3	400
		240V		0.9				

NOTES

A SINGLE COURT SCOREBOARD, SOLD AS COURT 1 ONLY, SHOULD BE SET WITH ADDRESS 11 (DRIVER) AND 221 (TNMC) IN MANUFACTURING.

IF SEVERAL SINGLE COURT SCOREBOARDS ARE SOLD, THEY WILL NEED TO BE DESIGNATED COURT 1, 2, 3, ETC. THEN SET THE ADDRESSES FOR THE SCOREBOARDS TO MATCH THE COURT NUMBER, IN MANUFACTURING.

MODEL	ADDRESS	VOLTAGE	VINYL CAPTIONS		TNMC PAIR 6" (3/4)		TNMC PAIR 8" (1)	
			WATTS	AMPS	WATTS	AMPS	WATTS	AMPS
TN-2505	A1 20 TNMC 230	120V	200	1.7	300	2.5	1.3	400
		240V		0.9				
OTHER TEAM SCORE, OPT. TOD, SECTIONS	A1 20 TNMC 230	120V	200	1.7	300	2.5	1.3	400
		240V		0.9				

MULTI COURT MODELS

TN-2560 THRU TN-2563 ARE MULTI-SECTIONAL SCOREBOARD MODELS. THEY ARE MADE UP OF SEVERAL SINGLE COURT ASSEMBLIES, BUT NEED TO HAVE THE ADDRESS SETTINGS CONFIGURED FOR EACH COURT IT WILL REPRESENT. SEE LEFT DETAILS FOR INSTRUCTIONS.

NO POWER INFORMATION CHANGES REQUIRED.

REV 01	DATE: 10 SEP 13	UPDATED DRAWING TO BE A POWER AND ADDRESS DOCUMENT	BY: MWM
DAKTRONICS, INC. BROOKINGS, SD 57006		THE CONCEPTS EXPRESSED AND DETAILS SHOWN ON THIS DRAWING ARE CONFIDENTIAL AND PROPRIETARY. DO NOT REPRODUCE BY ANY MEANS WITHOUT THE EXPRESSED WRITTEN CONSENT OF DAKTRONICS, INC. COPYRIGHT 2013 DAKTRONICS, INC.	
DO NOT SCALE DRAWING			
PROJ: TENNIS SCOREBOARDS			
TITLE: POWER AND ADDRESS DETAILS; INDOOR TENNIS SCOREBOARDS			
DESIGN: KBIERBA		DRAWN: KBIERBA	DATE: 24 MAY 11
SCALE: NONE			
SHEET	REV	JOB NO.	FLWC-TYPE-SIZE
	01	P1164	E-03-B
			1054354

Appendix E: Daktronics Warranty and Limitation of Liability

**DAKTRONICS
WARRANTY AND LIMITATION OF LIABILITY**

This Warranty and Limitation of Liability (the "Warranty") sets forth the warranty provided by Daktronics with respect to the Equipment. By accepting delivery of the Equipment, Purchaser agrees to be bound by and accept these terms and conditions. All defined terms within the Warranty shall have the same meaning and definition as provided elsewhere in the Agreement.

DAKTRONICS WILL ONLY BE OBLIGATED TO HONOR THE WARRANTY SET FORTH IN THESE TERMS AND CONDITIONS UPON RECEIPT OF FULL PAYMENT FOR THE EQUIPMENT.

1. Warranty Coverage

A. Daktronics warrants to the original end-user that the Equipment will be free from Defects (as defined below) in materials and workmanship for a period of one (1) year (the "Warranty Period"). The warranty period shall commence on the earlier of: (i) four weeks from the date that the equipment leaves Daktronics' facility; or (ii) Substantial Completion as defined herein. The warranty period shall expire on the first anniversary of the commencement date.

"Substantial Completion" means the operational availability of the Equipment to the Purchaser in accordance with the Equipment's specifications, without regard to punch-list items, or other non-substantial items which do not affect the operation of the Equipment.

B. Daktronics' obligation under this Warranty is limited to, at Daktronics' option, replacing or repairing, any Equipment or part thereof that is found by Daktronics not to conform to the Equipment's specifications. Unless otherwise directed by Daktronics, any defective part or component shall be returned to Daktronics for repair or replacement. Daktronics may, at its option, provide on-site warranty service. Daktronics shall have a reasonable period of time to make such replacements or repairs and all labor associated therewith shall be performed during regular working hours. Regular working hours are Monday through Friday between 8:00 a.m. and 5:00 p.m. at the location where labor is performed, excluding any holidays observed by either Purchaser or Daktronics.

C. Daktronics shall pay ground transportation charges for the return of any defective component of the Equipment. If returned Equipment is repaired or replaced under the terms of this warranty, Daktronics will prepay ground transportation charges back to Purchaser; otherwise, Purchaser shall pay transportation charges to return the Equipment back to the Purchaser. All returns must be pre-approved by Daktronics before shipment. Daktronics shall not be obligated to pay freight for any unapproved return. Purchaser shall pay any upgraded or expedited transportation charges.

D. Any replacement parts or Equipment will be new or serviceably used, comparable in function and performance to the original part or Equipment, and warranted for the remainder of the Warranty Period. Purchasing additional parts or Equipment from the Seller does not extend this Warranty Period.

E. Defects shall be defined as follows. With regard to the Equipment (excepting LEDs), a "Defect" shall refer to a material variance from the design specifications that prohibit the Equipment from operating for its intended use. With respect to LEDs, "Defects" are defined as LED pixels that cease to emit light. The limited warranty provided by Daktronics does not impose any duty or liability upon Daktronics for partial LED pixel degradation. Nor does the limited warranty provide for the replacement or installation of communication methods including but not limited to, wire, fiber optic cable, conduit, trenching, or for the purpose of overcoming local site interference radio equipment substitutions.

THIS LIMITED WARRANTY IS THE ONLY WARRANTY APPLICABLE TO THE EQUIPMENT AND REPLACES ALL OTHER WARRANTIES OR CONDITIONS, EXPRESS OR IMPLIED, INCLUDING, BUT NOT LIMITED TO, THE IMPLIED WARRANTIES OR CONDITIONS OF MERCHANTABILITY AND FITNESS FOR A PARTICULAR PURPOSE. SPECIFICALLY, EXCEPT AS PROVIDED HEREIN, THE SELLER UNDERTAKES NO RESPONSIBILITY FOR THE QUALITY OF THE EQUIPMENT OR THAT THE EQUIPMENT WILL BE FIT FOR ANY PARTICULAR PURPOSE FOR WHICH PURCHASER MAY BE BUYING THE EQUIPMENT. ANY IMPLIED WARRANTY IS LIMITED IN DURATION TO THE WARRANTY PERIOD. NO ORAL OR WRITTEN INFORMATION, OR ADVICE GIVEN BY THE COMPANY, ITS AGENTS OR EMPLOYEES, SHALL CREATE A WARRANTY OR IN ANY WAY INCREASE THE SCOPE OF THIS LIMITED WARRANTY.

THIS LIMITED WARRANTY IS NOT TRANSFERABLE.

2. Exclusion from Warranty Coverage

The limited warranty provided by Daktronics does not impose any duty or liability upon Daktronics for:

A. Any damage occurring, at any time, during shipment of Equipment unless otherwise provided for in the Agreement. When returning Equipment to Daktronics for repair or replacement, Purchaser assumes all risk of loss or damage, and agrees to use any shipping containers that might be provided by Daktronics and to ship the Equipment in the manner prescribed by Daktronics;

B. Any damage caused by the unauthorized adjustment, repair or service of the Equipment by anyone other than personnel of Daktronics or its authorized repair agents;



C. Damage caused by the failure to provide a continuously suitable environment, including, but not limited to: (i) neglect or misuse, (ii) a failure or sudden surge of electrical power, (iii) improper air conditioning or humidity control, or (iv) any other cause other than ordinary use;

D. Damage caused by fire, flood, earthquake, water, wind, lightning or other natural disaster, strike, inability to obtain materials or utilities, war, terrorism, civil disturbance or any other cause beyond Daktronics' reasonable control;

E. Failure to adjust, repair or replace any item of Equipment if it would be impractical for Daktronics personnel to do so because of connection of the Equipment by mechanical or electrical means to another device not supplied by Daktronics, or the existence of general environmental conditions at the site that pose a danger to Daktronics personnel;

F. Any statements made about the product by salesmen, dealers, distributors or agents, unless such statements are in a written document signed by an officer of Daktronics. Such statements as are not included in a signed writing do not constitute warranties, shall not be relied upon by Purchaser and are not part of the contract of sale;

G. Any damage arising from the use of Daktronics products in any application other than the commercial and industrial applications for which they are intended, unless, upon request, such use is specifically approved in writing by Daktronics; or

H. Any performance of preventive maintenance.

3. Limitation of Liability

Daktronics shall be under no obligation to furnish continued service under this Warranty if alterations are made to the Equipment without the prior written approval of Daktronics.

It is specifically agreed that the price of the Equipment is based upon the following limitation of liability. In no event shall Daktronics (including its subsidiaries, affiliates, officers, directors, employees, or agents) be liable for any special, consequential, incidental or exemplary damages arising out of or in any way connected with the Equipment or otherwise, including but not limited to damages for lost profits, cost of substitute or replacement equipment, down time, lost data, injury to property or any damages or sums paid by Purchaser to third parties, even if Daktronics has been advised of the possibility of such damages. The foregoing limitation of liability shall apply whether any claim is based upon principles of contract, tort or statutory duty, principles of indemnity or contribution, or otherwise.

In no event shall Daktronics be liable to Purchaser or any other party for loss, damage, or injury of any kind or nature arising out of or in connection with this Warranty in excess of the purchase price of the Equipment actually delivered to and paid for by the Purchaser. The Purchaser's remedy in any dispute under this Warranty shall be ultimately limited to the Purchase Price of the Equipment to the extent the Purchase Price has been paid.

4. Assignment of Rights

The Warranty contained herein extends only to the original end-user (which may be the Purchaser) of the Equipment and no attempt to extend the Warranty to any subsequent user-transferee of the Equipment shall be valid or enforceable without the express written consent of Daktronics.

5. Dispute Resolution

Any dispute between the parties will be resolved exclusively and finally by arbitration administered by the American Arbitration Association ("AAA") and conducted under its rules, except as otherwise provided below. The arbitration will be conducted before a single arbitrator. The arbitration shall be held in Brookings, South Dakota. Any decision rendered in such arbitration proceedings will be final and binding on each of the parties, and judgment may be entered thereon in any court of competent jurisdiction. This arbitration agreement is made pursuant to a transaction involving interstate commerce, and shall be governed by the Federal Arbitration Act.

6. Governing Law

The rights and obligations of the parties under this warranty shall not be governed by the provisions of the United Nations Convention on Contracts for the International Sales of Goods of 1980. Both parties consent to the application of the laws of the State of South Dakota to govern, interpret, and enforce all of Purchaser and Daktronics rights, duties, and obligations arising from, or relating in any manner to, the subject matter of this Warranty, without regard to conflict of law principles.

7. Availability of Extended Service Agreement

For Purchaser's protection, in addition to that afforded by the warranties set forth herein, Purchaser may purchase extended warranty services to cover the Equipment. The Extended Service Agreement, available from Daktronics, provides for electronic parts repair and/or on-site labor for an extended period from the date of expiration of this warranty. Alternatively, an Extended Service Agreement may be purchased in conjunction with this warranty for extended additional services. For further information, contact Daktronics Customer Service at 1-800-DAKTRONics (1-800-325-8766).