

**Daktronics ColorSmart[®]
Basketball
LED Scoreboards**

Display Manual

ED-16711

Rev 9 – 15 January 2013

DAKTRONICS

Models			
BB-3101	BB-3115	SD-3101	
BB-3103	BB-3121	SD-3102	
BB-3105	BB-3123	SD-3103	
BB-3107	BB-3125		
BB-3114	BB-3142		

Please fill in the information below for your display; use it for reference when calling Daktronics for assistance.

Scoreboard Serial No. _____

Scoreboard Model No. _____

Date Installed _____

DAKTRONICS, INC.

Copyright © 2007-2013

All rights reserved. While every precaution has been taken in the preparation of this manual, the publisher assumes no responsibility for errors or omissions. No part of this book covered by the copyrights hereon may be reproduced or copied in any form or by any means – graphic, electronic, or mechanical, including photocopying, taping, or information storage and retrieval systems – without written permission of the publisher.

All Sport[®], ColorSmart[®], and UniView[®] are trademarks of Daktronics, Inc. All others are trademarks of their respective companies.

Table of Contents

Section 1:	Introduction	1
1.1	Scoreboard Controllers	1
1.2	Scoreboard Label	2
1.3	Model Number	2
1.4	Resources	2
1.5	Daktronics Nomenclature	3
1.6	Product Safety Approval	3
Section 2:	Specifications	5
Section 3:	Mechanical Installation	7
3.1	Lifting the Scoreboard	7
3.2	Scoreboard & Statistics Display Mounting	8
3.3	Suspension Mounting Kit	8
3.4	Shot Clock Mounting	9
3.5	Corner Mounting	9
3.6	Ad Panel Mounting	9
3.7	Scoreboard Protective Devices	9
Section 4:	Electrical Installation	11
4.1	Installation Overview	11
4.2	Power	12
	Grounding	12
4.3	Power-On Self-Test (POST)	13
	Radio Settings	13
4.4	Scoreboard Signal Connection	13
4.5	Statistics Display Signal Connection	14
4.6	Shot Clock Signal Connection	15
	Portable Shot Clock Installations	16
Section 5:	Scoreboard Troubleshooting	17
5.2	Component Access & Locations	19
5.3	Replacing Digits	20
5.4	LED Drivers	21
	Replacing a Driver	23
	Setting the Driver Address	24
5.5	Segmentation and Digit Designation	24
5.6	Schematics	24
5.7	Replacement Parts List	25
5.8	Daktronics Exchange and Repair & Return Programs	26
	Exchange Program	26
	Repair & Return Program	27
	Daktronics Warranty and Limitation of Liability	27
Section 6:	Scoreboard Options	29
6.1	Horns	29

	Adjusting Horn Volume.....	29
6.2	Radio Control.....	29
6.3	Visual Horn Indicator (VHI).....	29
6.5	Time Outs Left (TOL) Digits.....	30
6.6	Double Bonus Indicators.....	30
6.7	Team Name Message Centers & Electronic Captions.....	30
Section 7:	TNMC & Electronic Caption Troubleshooting & Maintenance	31
7.1	Display Overview	31
7.2	Initialization Information at Startup.....	32
7.3	Display Troubleshooting Table	32
7.4	Power & Signal Summary	33
7.5	Component Locations & Access.....	33
7.6	Modules.....	34
	Replacing Modules	34
7.7	Power Supplies.....	34
	Replacing a Power Supply	34
7.8	Display Maintenance	35
7.9	Replacement Parts List	35
Appendix A:	Mechanical Specification Drawings.....	37
Appendix B:	Electrical Specification Drawings.....	39
Appendix C:	Scoreboard Options	41
Appendix D:	Schematic Drawings.....	43
Appendix E:	Additional Reference Drawings.....	45
Appendix F:	Daktronics Warranty and Limitation of Liability	47

Section 1: Introduction

This manual explains the installation and maintenance of Daktronics ColorSmart® Indoor Basketball LED Scoreboards, as well as ColorSmart compatible Game/Shot Clocks and Statistics Displays. For additional information regarding the safety, installation, operation, or service of this display, refer to the telephone numbers listed in **Section 5.8**. This manual is not specific to a particular installation.

Important Safeguards:

- Please read and understand all instructions before beginning the installation process.
- Do not drop control equipment or allow it to get wet.
- Do not disassemble control equipment or electronic controls of the display; failure to follow this safeguard will make the warranty null and void.
- Disconnect display power when not in use or when servicing.
- Disconnect display power before servicing power supplies to avoid electrical shock. Power supplies run on high voltage and may cause physical injury if touched while powered.
- Do not modify the scoreboard structure or attach any panels or coverings to the scoreboard without the express written consent of Daktronics, Inc.

Project-specific information takes precedence over any other general information found in this manual.

1.1 Scoreboard Controllers

Daktronics ColorSmart scoreboards are designed for use with the All Sport® 5500 series control console. This console uses keyboard overlays (sport inserts) to control numerous sports and scoreboard models. Refer to the following manual for operating instructions:

- **All Sport 5500 Control Console Operation Manual (ED-16809)**

The control console manual is available online at www.daktronics.com/manuals.

1.2 Scoreboard Label

Serial and model numbers of a Daktronics scoreboard can be found on the ID label on the display, similar to that shown in **Figure 1**.



Figure 1: Display ID Label

Please list the model number, display serial number, and the date this display became operational in the blanks provided on the second page of this manual. When calling Daktronics customer service, please have this information available to ensure the request is serviced as quickly as possible.

1.3 Model Number

Daktronics scoreboards are differentiated by their model numbers and two-letter prefixes for each sport. Most Daktronics scoreboards also carry a two-number suffix that refers to indoor-outdoor status, power supply, and digit color.

BB	Basketball
SD	Statistics Display

-15	indoor scoreboards, 120 V, UniView® digits
-19	indoor scoreboards, 120 V, ColorSmart® digits

1.4 Resources

Figure 2 illustrates a Daktronics drawing label. The drawing number is located in the lower-right corner of a drawing. This manual refers to drawings by listing the last set of digits and the letter preceding them. In the example, the drawing would be referred to as **Drawing C-325405**.

THE CONCEPTS EXPRESSED AND DETAILS SHOWN IN THIS DRAWING ARE CONFIDENTIAL AND PROPRIETARY. DO NOT REPRODUCE BY ANY MEANS, INCLUDING ELECTRONICALLY, WITHOUT THE EXPRESSED WRITTEN CONSENT OF DAKTRONICS, INC. COPYRIGHT 2008 DAKTRONICS, INC.			
DAKTRONICS, INC. BROOKINGS, SD 57006			
PROJ: DAKTRONICS UNIVERSITY			
TITLE: SYSTEM RISER DIAGRAM			
DES. BY: AORMESH		DRAWN BY: AORMESH	
DATE: 15 JAN 08			
REVISION	APPR BY-	14963-R01C-325405	
00	SCALE: NONE		

Figure 2: Daktronics Drawing Label

Reference Drawing:

System Riser Diagram.....**Drawing C-325405**

Daktronics identifies manuals by the DD or ED number located on the cover page of each manual. For example, this manual would be referred to as **ED-16711**.

1.5 Daktronics Nomenclature

Most components within this display carry a white label that lists the part number of the unit. If a component is not found in the Replacement Parts List in **Section 5.7**, use the label to order a replacement. **Figure 3** illustrates a typical label. The part number is in bold.

Main Component Labels	
Part Type	Part Number
Individual circuit board	0P-XXXX-XXXX
Assembly; a collection of circuit boards	0A-XXXX-XXXX
Wire or cable	W-XXXX
Fuse	F-XXXX
Transformer	T-XXXX
Metal part	M-XXX
Fabricated metal assembly	0S-XXXXXX
Specially ordered part	PR-XXXXX-X

Accessory Labels	
Component	Label
Termination block for power or signal cable	TBXX
Grounding point	EXX
Power or signal jack	JXX
Power or signal plug for the opposite jack	PXX

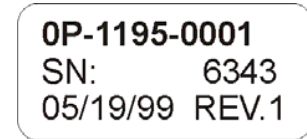

Figure 3: Typical Label

Following the Replacement Parts List is the Daktronics Exchange Policy and the Repair & Return Program. Refer to these instructions if replacing or repairing any display component.

1.6 Product Safety Approval

Daktronics ColorSmart scoreboards are ETL listed and tested to CSA standards, and CE-labeled for indoor use. Contact Daktronics with any questions regarding testing procedures.

Section 2: Specifications

The chart on the following pages details all of the mechanical specifications, circuit specifications, and power requirements for each display in this manual. Models are listed in alphanumeric order.

Notes:

- 1) All displays require a 120 VAC, 15 A circuit.
- 2) Values in [Brackets] indicate scoreboards with Team Name Message Centers (TNMCs) or statistic displays with electronic captions.

Model	Dimensions: Height, Width, Depth	Uncrated Weight	Watts	Amps	Driver # & Address
BB-3101-19	4'-0" H, 8'-0" W, 6" D (1219 mm, 2438 mm, 152 mm)	120 lb 55 kg [135 lb 61 kg]	200 W [300 W]	1.7 A [2.5 A]	A1 17
BB-3103-19	6'-0" H, 8'-0" W, 6" D (1829 mm, 2438 mm, 152 mm)	180 lb 82 kg [195 lb 88 kg]	200 W [300 W]	1.7 A [2.5 A]	A1 17
BB-3105-19	4'-0" H, 10'-0" W, 6" D (1219 mm, 3048 mm, 152 mm)	150 lb 68 kg [165 lb 75 kg]	200 W [300 W]	1.7 A [2.5 A]	A1 17
BB-3107-19	6'-0" H, 10'-0" W, 6" D (1829 mm, 3048 mm, 152 mm)	225 lb 102 kg [240 lb 109 kg]	200 W [300 W]	1.7 A [2.5 A]	A1 17
BB-3114-15	1'-7" H, 1'-10" W, 6" D (483 mm, 559 mm, 152 mm)	15 lb 7 kg	40 W	0.3 A	A1 2
BB-3115-15	2'-4" H, 2'-5" W, 6" D (711 mm, 737 mm, 152 mm)	30 lb 14 kg	250 W	2.5 A	A1 1
BB-3121-19	2'-6" H, 10'-0" W, 6" D (762 mm, 3048 mm, 152 mm).	95 lb 43 kg [110 lb 50 kg]	200 W [300 W]	1.7 A [2.5 A]	A1 17

Model	Dimensions: Height, Width, Depth	Uncrated Weight	Watts	Amps	Driver # & Address
BB-3123-19	6'-0" H, 10'-0" W, 6" D (1829 mm, 3048 mm, 152 mm)	230 lb 104 kg [245 lb 111 kg]	400 W [500 W]	3.3 A [4.2 A]	A1 17 A2 14
BB-3125-19	4'-0" H, 10'-0" W, 6" D (1219 mm, 3048 mm, 152 mm)	150 lb 68 kg [165 lb 75 kg]	200 W [300 W]	1.7 A [2.5 A]	A1 17
BB-3142-19	3'-0" H, 6'-6" W, 6" D (914 mm, 1981 mm, 152 mm)	90 lb 41 kg	200 W	1.7 A	A1 17
SD-3101-15*	6'-0" H, 3'-6" W, 6" D (1829 mm, 1067 mm, 152 mm)	80 lb 36 kg [88 lb 40 kg]	400 W [500 W]	3.3 A [4.2 A]	<i>Left Display:</i> A1 23 A2 24 <i>Right Display:</i> A1 25 A2 26
SD-3102-15*	6'-0" H, 3'-6" W, 6" D (1829 mm, 1067 mm, 152 mm)	90 lb 41 kg [98 lb 45 kg]	400 W [500 W]	3.3 A [4.2 A]	<i>Left Display:</i> A1 23 A2 24 <i>Right Display:</i> A1 25 A2 26
SD-3103-15*	6'-0" H, 4'-0" W, 6" D (1829 mm, 1219 mm, 152 mm)	100 lb 45 kg [108 lb 49 kg]	600 W [700 W]	5 A [5.8 A]	<i>Left Display:</i> A1 23 A2 24 A3 27 <i>Right Display:</i> A1 25 A2 26 A3 28

* All dimensions, weight, and power specifications are for one statistic display only.

Section 3: Mechanical Installation

Mechanical installation consists of lifting and permanently mounting the scoreboard, statistics panels, and game/shot clocks. The mechanical specification drawings listed in **Appendix A** show the recommended number and spacing of wall anchors for specific scoreboard models.

Be sure that the installation complies with local building codes.

Note: Daktronics does not assume any liability for any installation derived from the information provided in this manual or installations designed and installed by others.

3.1 Lifting the Scoreboard

Most Daktronics ColorSmart scoreboards and statistics panels are shipped equipped with at least one eyebolt for lifting, as well as pre-drilled holes along the top and bottom of each cabinet for wall attachment. Eyebolts are located along the top of the cabinet for each scoreboard or scoreboard section. (The smaller game/shot clocks do not require eyebolts and are not equipped with them.) Daktronics indoor scoreboards use $\frac{3}{8}$ " eyebolts.

Daktronics strongly recommends using a spreader bar, or lifting bar, to lift the display. Spreader bars ensure the force on the eyebolts remains straight up, minimizing lifting stress.

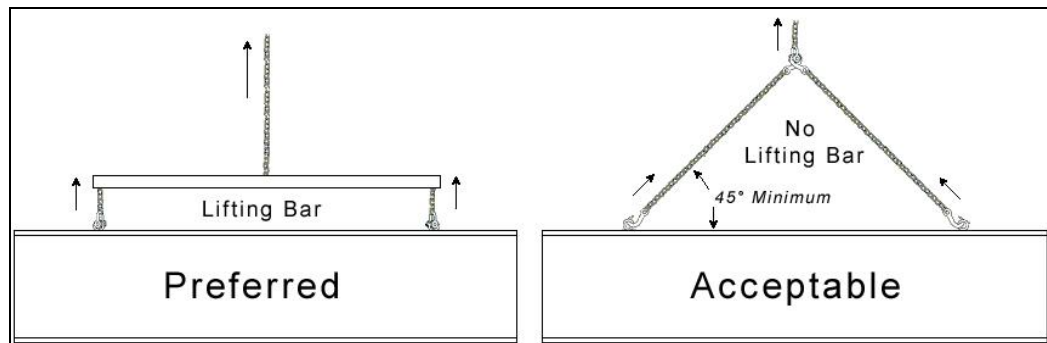

Figure 4: Lifting Methods

Figure 4 illustrates the preferred scoreboard lifting method on the left and an acceptable alternative lifting method on the right. When lifting the display:

- Use a spreader bar if possible.
- Use every lifting point provided.

Cables and chains attached to the eyebolts and directly to a center lifting point, as shown in the right-hand example in **Figure 4**, can create a dangerous lateral force on the eyebolts and may cause the eyebolts to fail. The smaller the angle between the cable and the top of the display, the lighter the sign must be to safely lift it. If this method must be used, ensure a minimum angle between the chain and scoreboard of at least 45°.

Do NOT attempt to lift the display if the angle is less than 45°.

Exceeding load angles or weight limits could cause the bolts in the scoreboard cabinet to buckle, resulting in serious damage to the scoreboard or injury to personnel. Also, loads should be applied directly in the plane of the eyebolt as shown in **Figure 5**.

Note: Daktronics assumes no liability for damages resulting from incorrect setup or lifting methods. Eyebolts are intended for lifting only. Do not attempt to permanently support the display by the eyebolts without the suspension mounting kit (see **Section 3.3**).

Small Daktronics scoreboards are not equipped with eyebolts, and instead use two lifting straps that encircle the scoreboard. It is recommended to use a spreader bar with the straps.

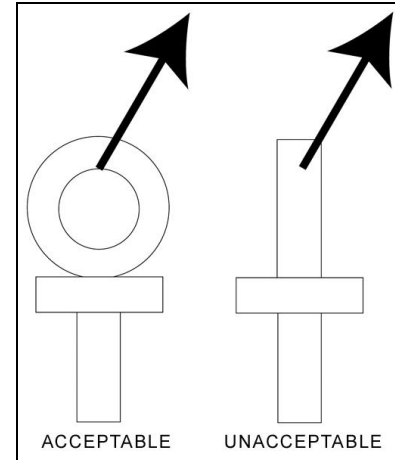

Figure 5: Eyebolt Plane Load

3.2 Scoreboard & Statistics Display Mounting

1. Use the eyebolts at the top of the scoreboard frame to lift the display into position for mounting.

Note: For statistic displays, verify the correct HOME or GUEST display by looking at the label on top of the cabinet to determine whether it should be mounted to the left or right of the scoreboard.

2. Secure the display to the wall by attaching mounting hardware through all holes on the top and bottom rear flanges of the display to a pre-drilled hole in the wall (**Figure 6**).

For mounting locations, weights, and hardware suggestions, refer to the model-specific mechanical specification drawings listed in **Appendix A**.

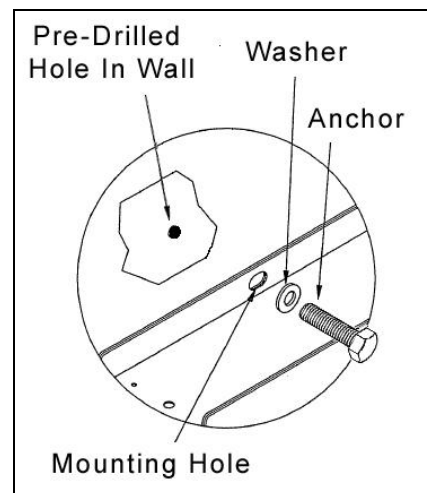

Figure 6: Wall Mounting

Due to the variety of wall materials used in sports facilities, Daktronics cannot anticipate a user's individual installation needs or provide mounting hardware suitable for every installation. Choose a method of installation that will safely support the weight of the display.

3.3 Suspension Mounting Kit

One of several mounting options with the ColorSmart scoreboards is a suspension lift eye installation, which requires a special mounting kit (part # 0A-1237-0016). Contact Daktronics about any installation that involves permanently suspending the scoreboard.

1. Secure the mounting angle with the $\frac{3}{8}$ " nut to each side of the scoreboard with the included screws. Install the eyebolts into the nut on the mounting angle.
2. Attach suspension cables to the eyebolt using a shackle and pin (all of this equipment is provided by others).

Notes:

- 1) Daktronics recommends that two cables be used at each end of the scoreboard.
- 2) Cables and hardware must be specified by a licensed engineer.
- 3) Do not attach suspension hardware to ad panels – attach to top of scoreboard.
- 4) This installation method must not be used to support scoreboard with message centers and/or backlit ad panels attached.
- 5) The total weight of scoreboard and accessories must not exceed 500 lb (223 kg).

Similar to the eyebolts used to lift the scoreboard, the suspension eyebolts have a maximum angle at which they can safely support the display. The ideal angle is perpendicular to the top of the scoreboard, but this angle may extend up to 30° out to either side of the display.

Refer to **Drawing A-148644** in **Appendix C** for more information.

3.4 Shot Clock Mounting

Single-sided shot clocks may be mounted to a wall in the same manner as a scoreboard or statistics display. Multi-sided shot clocks are frequently mounted to vertical backstop supports. Refer to **Drawing A-91230** in **Appendix C** for game/shot clock mounting information.

Note: Daktronics does not supply the hardware or brackets to mount shot clocks to backstops and is not responsible for the integrity of suitability of mounting systems manufactured and installed by others.

3.5 Corner Mounting

Certain scoreboard models may be mounted in a corner, rather than flat against the wall, using a special mounting bracket kit. For more information on the corner mounting option, refer to **Drawing A-150831** in **Appendix C**.

3.6 Ad Panel Mounting

Refer to **Drawing A-147668** in **Appendix C** for typical ad panel mounting (similar to **Scoreboard & Statistics Display Mounting** shown above) or **Drawing A-156134** for instructions on mounting ad panels to the top or bottom of a scoreboard.

3.7 Scoreboard Protective Devices

Daktronics Tuff Sport displays have been designed so that a normal basketball or volleyball impact will not damage the LEDs or display cabinet, reducing the need for protective devices. Some users, however, may still wish to have additional protection from other projectiles, and in these cases, Daktronics provides optional protective devices. Refer to the **Protective Screen Installation Instructions (ED-5423)**, available online at www.daktronics.com/manuals for more information about installing protective devices.

Note: Scoreboard protection devices not provided by Daktronics must be approved by Daktronics prior to installation. Failure to follow this approval procedure will void the scoreboard warranty.

Section 4: Electrical Installation

CAUTION: Only qualified individuals should access the electrical components of the display and its associated equipment. It is the responsibility of the electrical contractor to ensure that all electrical work meets or exceeds local and national codes.

Daktronics engineering staff must approve all changes or the warranty will be void.

4.1 Installation Overview

The diagram shown in **Figure 7** illustrates a typical wired setup between a scoreboard and the control system. Daktronics part numbers are shown in parentheses. **Drawings A-124686, A-124688, A-125415, and A-125417** in **Appendix E** also show power and signal layouts.

Control signal cable and some junction boxes are not provided as part of this system and can be purchased locally or from Daktronics.

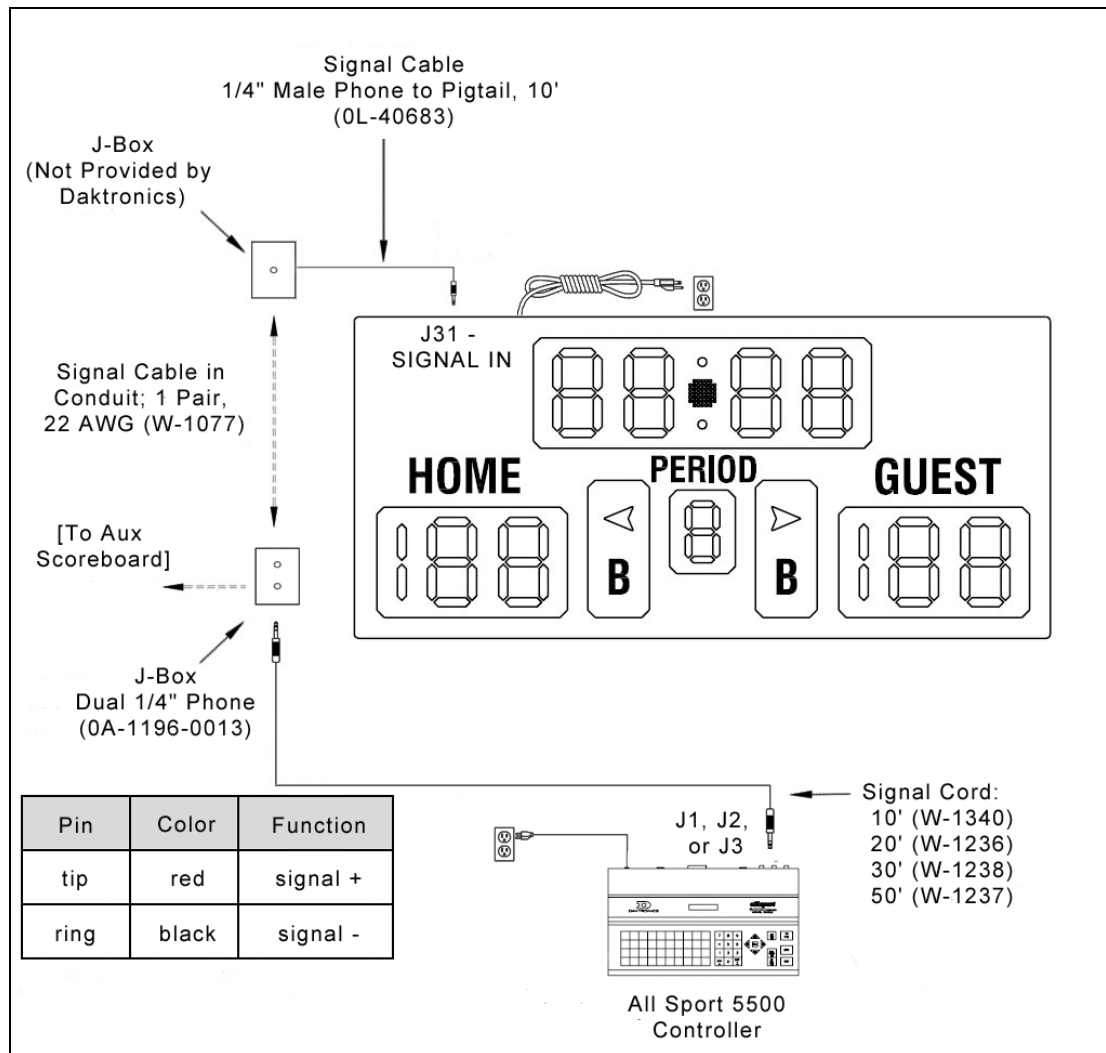

Figure 7: Wired Installation

The diagram shown in **Figure 8** illustrates a typical wireless setup between a scoreboard and the control system. Refer to **Section 6.2** for more information about the wireless radio option.

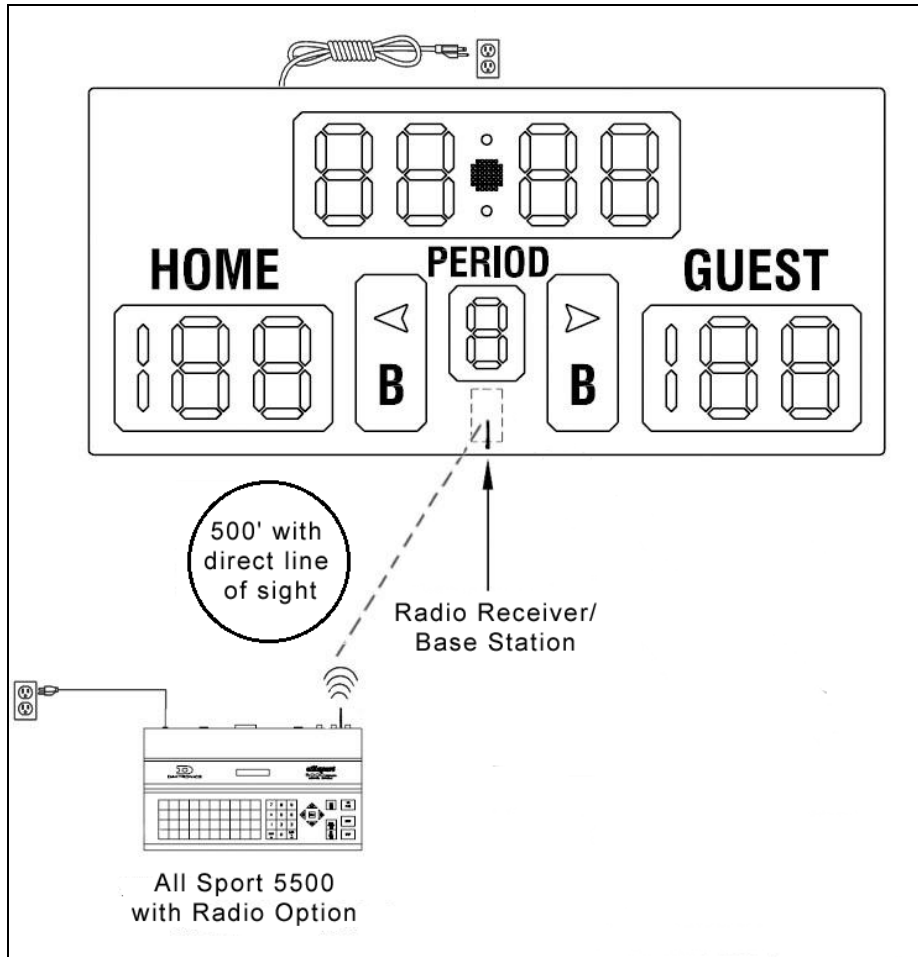

Figure 8: Wireless Installation

4.2 Power

Each scoreboard features a 120 VAC power cord with a three-prong plug. Install a grounded receptacle near the equipment so that the power cord can easily reach it. The control console also requires a 120 VAC receptacle and uses less than 1 A of power.

Grounding

Connect the scoreboard to earth ground. Proper grounding assures reliable equipment operation and protects the equipment against damaging electrical disturbances and lightning. Daktronics recommends a resistance-to-ground of 10 ohms or less. The electrical contractor performing the electrical installation can verify ground resistance. Daktronics Sales and Service personnel can also provide this service. The grounding connection on the power cord's three-prong plug connects to the shell of the scoreboard.

Note: The customer must properly ground the outlet according to local and national codes. Failure to ground the outlet voids the warranty for the scoreboard.

4.3 Power-On Self-Test (POST)

The scoreboard performs a self-test each time that power is turned on and the control console is powered off or not attached to the scoreboard. If the control console is attached and powered on, the self-test does not run, and data from the control console is displayed on the scoreboard after a brief period of time. Each scoreboard self-test pattern will vary depending on the scoreboard model, the number of drivers and types of digits. **Figure 9** shows an example of the LED bar test pattern that each digit performs.

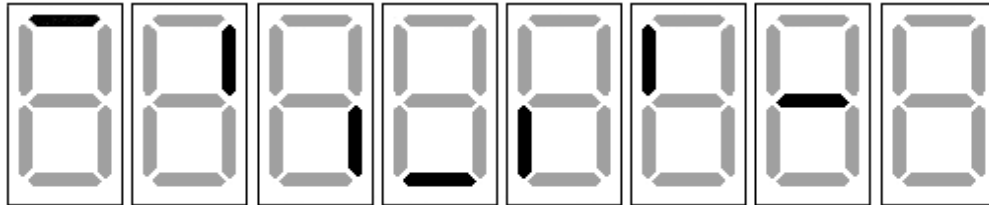

Figure 9: Digit Segment POST

Radio Settings

If a radio receiver is installed (see **Section 6.2**), the radio broadcast settings (“b1”) and the channel settings (“C1”) will be displayed in the Home and Guest or clock digits (**Figure 10**) during the POST. These values must match the settings in the control console (refer to the appropriate control console manual listed in **Section 1.1**).



Figure 10: Radio Settings in POST

4.4 Scoreboard Signal Connection

Signal installation (for systems without radio control) requires routing control cable from the scoreboard control console to a signal junction box (J-box) near the display. See also **Drawing A-28124** in **Appendix E** and **Drawing A-125316** in **Appendix D**.

1. At a minimum, use a paired, 22 AWG shielded cable (Daktronics part # W-1077) and connect the cable to a dual 1/4" J-box at the control console end.

Using a dual J-box for separate Main and Aux scoreboards lets operators control several displays with one controller, and they can also switch jacks to control individual boards using multiple controllers.

2. Route the cable from the J-box on the control console end to a J-box near the display.
3. Install the 1/4" phone plug (Daktronics part # 0L-40683) to the scoreboard end of the cable. Be sure to connect the cable shielding only in the J-box on this end.

Note: DO NOT connect cable shielding at the J-box near the control console.

4. Insert the plug into the Signal In (J31) jack located on the top of the scoreboard.
5. Connect a signal cable from the J-box to the J1, J2, or J3 jack on the back of the All Sport 5500 console.

If using a Main Clock Start/Stop Switch (0A-1166-0003), connect it to the J7 jack on the All Sport 5500 console.

4.5 Statistics Display Signal Connection

Figure 11 shows the connections required between a wired scoreboard and two statistics displays. Refer to Figure 7 for more information about connecting the signal wiring that runs from the scoreboard to the controller. See also Drawing A-124688 in Appendix E.

1. At a minimum, use a paired, 22 AWG shielded cable (Daktronics part # W-1077) and connect the cable to a dual 1/4" J-box at the control console end.
2. Route the cable from the J- box on the control console end to a J-box near the display.
3. Install the 1/4" phone plug (Daktronics part # 0L-40683) to the display end of the cable. Be sure to connect the cable shielding only in the J-box on this end.

Note: DO NOT connect cable shielding at the J-box near the control console.

4. Route the 1/4" phone plug from the J-box near the display to the scoreboard.
5. Insert the plug into the Signal In (J31) jack located on the top of the scoreboard.
6. Connect a 1/4" phone plug between the Signal Out (J32) jack on top of the scoreboard to the Signal In (J31) jack on top of the right (GUEST) stat panel.
7. Connect another 1/4" phone plug between the Signal Out (J32) jack on top of the right (GUEST) stat panel to the Signal In (J31) jack on top of the left (HOME) stat panel.

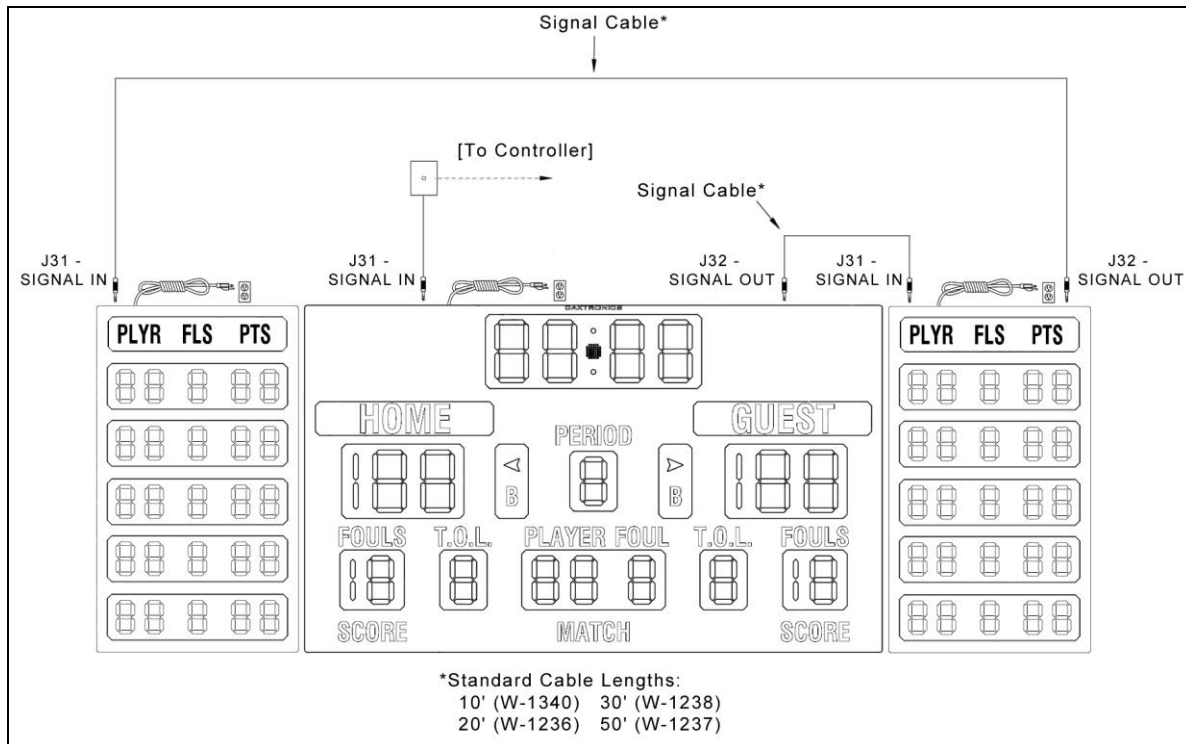

Figure 11: Statistic Display Installation

4.6 Shot Clock Signal Connection

For permanent shot/game clock installations (**Figure 12**), signal wiring may be routed from a J-box at the control console end and terminated at another J-box by the display, similar to the method used for scoreboards and stat displays. See also **Drawings A-124688** and **A-125415** in **Appendix E**.

1. At a minimum, use a paired, 22 AWG shielded cable (Daktronics part # W-1077) and connect the cable to a dual 1/4" J-box at the control console end.
2. Route the cable from the J-box on the control console end to a J-box near the display.
3. Install the 1/4" phone plug (Daktronics part # 0L-40683) to the shot clock end of the cable. Be sure to connect the cable shielding only in the J-box on this end.

Note: DO NOT connect cable shielding at the J-box near the control console.

4. Route the 1/4" phone plug from the J-box near the display to the first shot clock.
5. Insert the plug into the Signal In (J31) jack located on the side of the shot clock.
6. Repeat steps 1-5 for the other shot clock.
7. Connect a signal cable from the J-box to the J1, J2, or J3 jack on the back of the All Sport 5500 console.

If using an optional Shot Clock Start/Stop Switch (Daktronics part # 0A-1196-0031), connect it to the J7 jack.

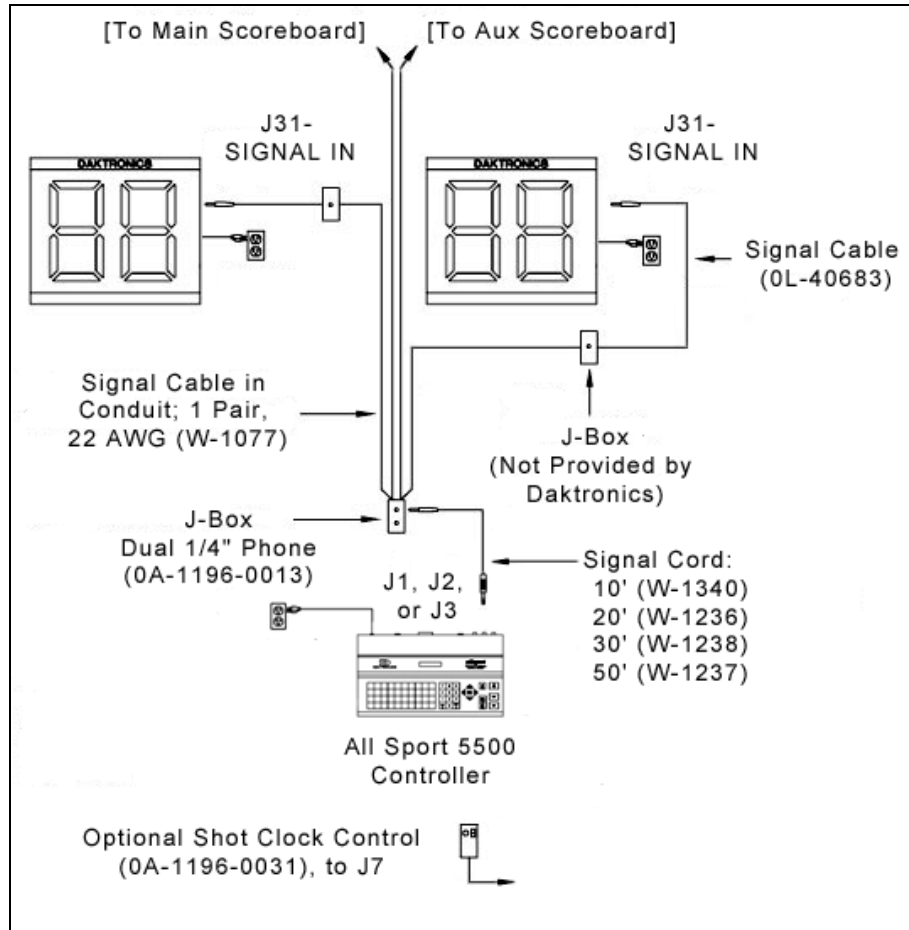

Figure 12: Shot Clock Installation

Portable Shot Clock Installations

Drawing A-98293 in **Appendix C** shows a typical installation for a shot clock mounted to a portable backstop structure. **Drawing A-124688** in **Appendix E** shows signal wiring to control console for portable shot clocks.

Portable shot clock model BB-3115 comes prewired with a twistlock male power inlet. A female plug is provided by Daktronics that must be attached to a power cord by the customer.

For installations that use LED backstop light strips, refer to the **LED End-of-Period Basketball Lighting Display Manual (ED-13652)**, available online at www.daktronics.com/manuals.

Section 5: Scoreboard Troubleshooting

IMPORTANT NOTES:

1. Always disconnect power before doing any repair work on the scoreboard.
2. Allow only qualified service personnel access to internal display electronics.
3. Disconnect power when not using the scoreboard.

5.1 Troubleshooting Table

The table below lists potential problems with the scoreboard and indicates possible causes and corrective actions. This list does not include every symptom that may be encountered, but it does present several of the most common situations that may occur.

Many of the solutions offered below provide references to other sections within this manual or to supplemental product manuals with further detail on how to fix the problem.

If a problem occurs that is not listed or that cannot be resolved using the solutions in the following table, contact Daktronics using the information provided in **Section 5.8**.

Problem	Possible Cause	Solution/Items to Check
Scoreboard doesn't light and console doesn't work	No power to the scoreboard	Check that the main circuit breaker for the scoreboard is on. Check that the scoreboard is receiving 120 VAC power.
	No power to console	Ensure the console is plugged into a 120 VAC power supply. Swap the console with one known to work correctly, and enter the proper sport code to test. Replace console if necessary.
Scoreboard digits don't light, but console works	No wired signal from console	Check that the scoreboard is receiving 120 VAC power. Check that the red DS2 LED on the driver lights up when sending commands from the control console (see Section 5.4).
	No radio signal from console	Cycle power to the scoreboard and watch for radio receiver broadcast/channel settings (see Section 4.3). Check that the green POWER and amber RADIO IN RANGE indicators on the radio receiver in the scoreboard light up when the control console is powered on. Keep the console between 20 to 500 feet from the scoreboard.

Problem	Possible Cause	Solution/Items to Check
		Move the console 20-30 feet from the scoreboard and test again. Verify that both the console and scoreboard antennae are securely tightened and in a vertical position.
		Replace the radio receiver.
	No signal to driver	Check that the scoreboard is receiving 120 VAC power.
		Check that the red DS2 LED on the driver lights up when sending commands from the control console (see Section 5.4). Swap the driver with one known to work correctly and with the same part number to verify the problem. Replace if necessary (see Section 5.4).
No power to driver	Check that the green DS1 LED on the driver is always lit up when the scoreboard is powered on (see Section 5.4).	
Scoreboard digits light, but not in the correct order	Incorrect sport code	Ensure the correct sport code is being used for the scoreboard model. Refer to the control console operation manual(see Section 1.1).
	Incorrect driver address	Check that the scoreboard driver(s) are set to the correct address(es) (see Section 5.4).
Scoreboard digits light, console works, but no display on scoreboard	No wired signal from console	(See solution on previous page)
	No radio signal from console	(See solution on previous page)
	Bad/damaged wiring	Check that the red DS2 LED on the driver lights up when sending commands from the control console (see Section 5.4).
Scoreboard works, but some LEDs always stay on	Short in digit or indicator circuit	Swap the digit/indicator with one known to work correctly to verify the problem. Replace if necessary (see Section 5.3).
Scoreboard works, but some LEDs do not light or they blink	Bad connection	Verify the power/signal connector on the back of the digit circuit board is secure (see Section 5.3).
	Bad digit or driver	Swap the digit/driver with one known to work correctly to verify the problem. Replace if necessary (see Section 5.3 for digits or Section 5.4 for drivers).

Problem	Possible Cause	Solution/Items to Check
Scoreboard works, but some digits do not light	Bad digit or driver	(see solution on previous page)
	Incorrect sport code	(see solution on previous page)
	Incorrect driver address	(see solution on previous page)
	Wrong console controlling scoreboard	Another console's radio signal could be transmitting to the scoreboard.
	Radio interference	There may be other radio transmissions in the area that overpower the console. If it is not possible to disable the interfering device, It may be necessary to run a wired signal connection instead.

5.2 Component Access & Locations

All ColorSmart indoor basketball displays are front-access scoreboards, meaning that internal electronic components and digits are reached by opening a face panel, an access door, or a digit panel on the front of the display.

Digit panels are typically held in place on the scoreboard face by two screws. To remove a digit, simply unfasten the screws and carefully lift it from the cabinet. The signal harness can then be removed from the connector on the back of the digit to completely free the digit and access internal components.

Remove non-digit access panels by unfastening the top, side or bottom screws holding it in place. Some panels are hinged and swing open when the screws are removed or loosened.

Component location varies with each scoreboard model, but drivers and power and signal components are typically mounted inside the scoreboard behind a digit panel. To locate the driver(s), look for a warning label similar to that shown in **Figure 13**.

Refer to the electrical and signal specification drawings in **Appendix B** for model-specific component layouts and access locations.



Figure 13: Power Warning Label

5.3 Replacing Digits

LEDs are embedded in a circuit board that is mounted to the back of a digit panel, as shown in **Figure 14**. Do not attempt to remove individual LEDs. In the case of a malfunctioning board, replace the entire digit circuit board.

To replace a digit circuit board:

1. Open the digit panel as described on the previous page.
2. Disconnect the power/signal connector from the back of the digit by squeezing together the locking tabs and pulling the connector free.
3. Use a $\frac{9}{32}$ " nut driver to remove the nuts securing the digits to the aluminum standoffs, and then lift the digit off the standoff/diffuser assembly.
4. Position a new digit over the standoffs, and tighten the nuts. It may be necessary to also tighten the standoffs if they became loose while removing the nuts.
5. Reconnect the power/signal connector.

Note: This is a keyed connector and it will attach in one way only. Do not attempt to force the connection.

6. Secure the digit panel to the display with the two screws, then power up and test the display to see if changing the digit has resolved the problem.

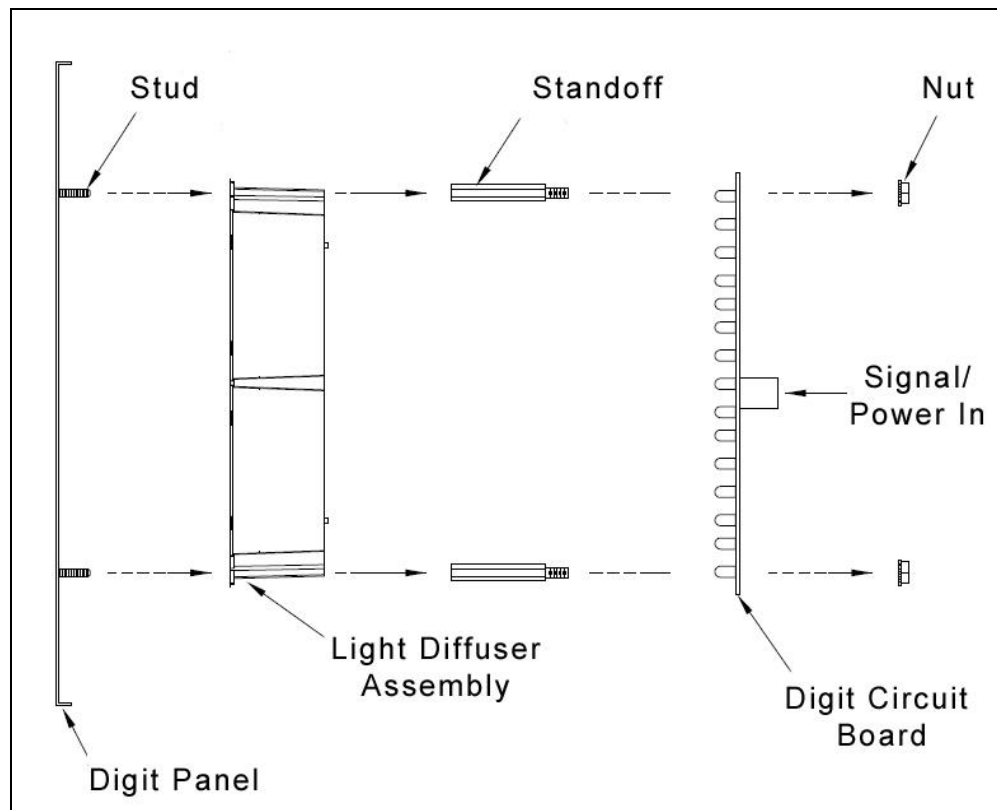

Figure 14: Digit Assembly

5.4 LED Drivers

In each scoreboard, one or more LED drivers perform the task of switching LEDs on and off. LED drivers are located inside of a driver enclosure. Refer to **Figure 15** to view the location and components of a ColorSmart driver enclosure.

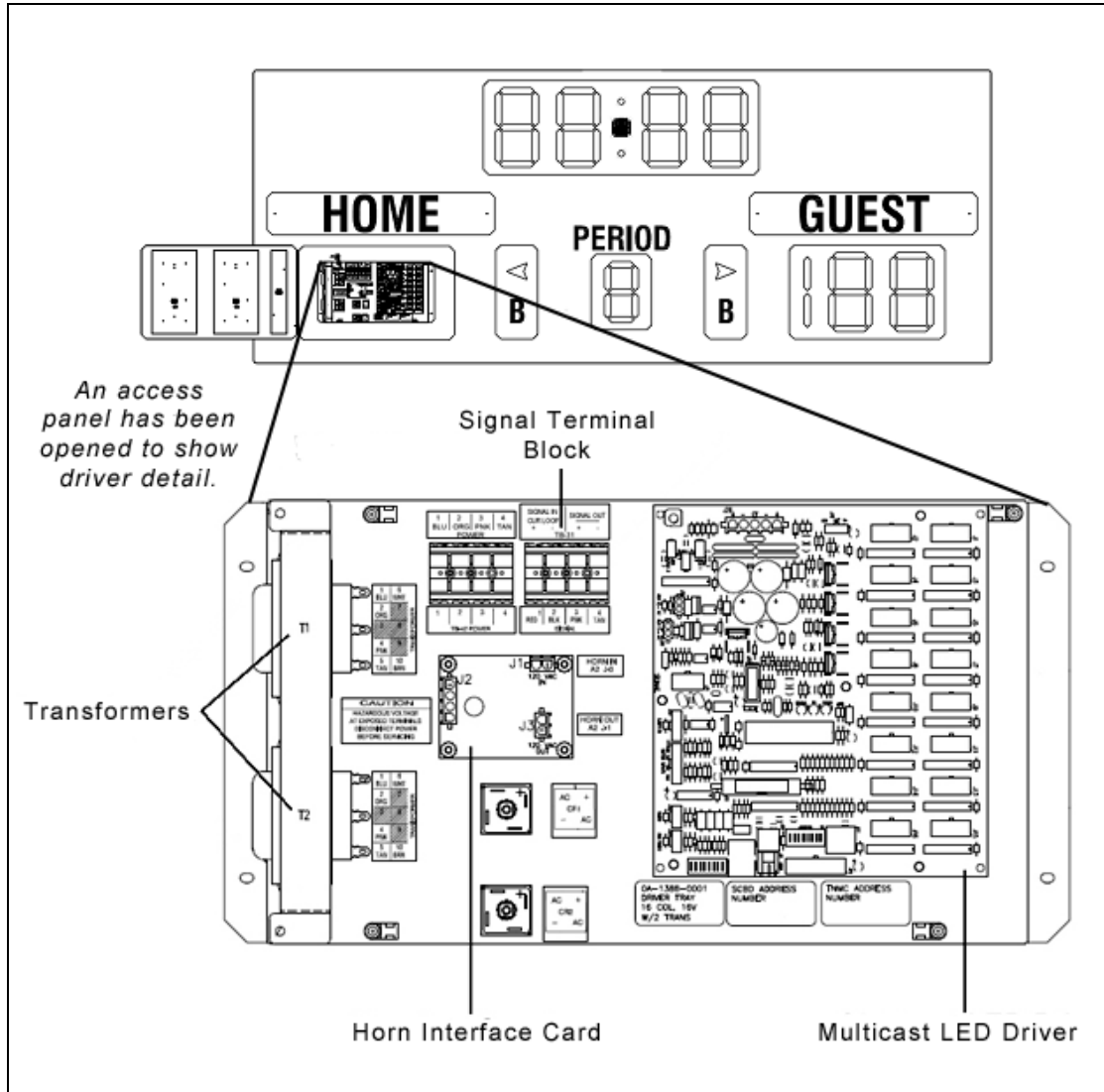

Figure 15: Driver Enclosure Location & Components

All ColorSmart scoreboards and ColorSmart compatible statistics displays use 16-column Multicast drivers (**Figure 15**), while smaller shot/game clocks use 4-column LED drivers. Several scoreboard models contain more than one driver to accommodate all of the digits and indicators. Refer to the electrical and signal specifications in **Appendix B** to determine the type and number of drivers for a particular scoreboard model.

Each driver has numerous connectors providing power and signal inputs and outputs to the scoreboard digits and indicators. The table on the following page shows the function of these connectors for a Multicast 16-column Driver:

Connector No.	Function
1-16	Output to digits and indicators
31	Control signal
26	Control for horn
S1	Address (DIP switch package)
S2	TNMC (DIP switch package)
24	Power

Refer to **Drawing A-284554** in **Appendix E** for detailed driver pin out/switch specifications.

The table below shows the function of the primary connectors for a 4-column driver:

Connector No.	Function
1-4	Output to digits and indicators
17	Main power & signal
19	Address plug
6-7	Horn Relay

Refer to **Drawing A-123783** in **Appendix E** for detailed driver pin out/switch specifications.

When troubleshooting driver problems, three LEDs labeled **DS1**, **DS2**, and **DS3**, provide the following diagnostic information:

LED	Color	Function	Operation	Summary
DS1	Green	Power	Steady on	DS1 will be on and steady to indicate the driver has power.
DS2	Red	Signal RX	Steady on or blinking	DS2 will be on or blinking when the driver is receiving a signal and off when there is no signal.
DS3	Amber	Status	Blinking	DS3 will be blinking at one second intervals to indicate the driver is running (not available on 4-column LED driver).

Note: While it is necessary to have the scoreboard powered on to check the LED indicators, always disconnect scoreboard power before servicing.

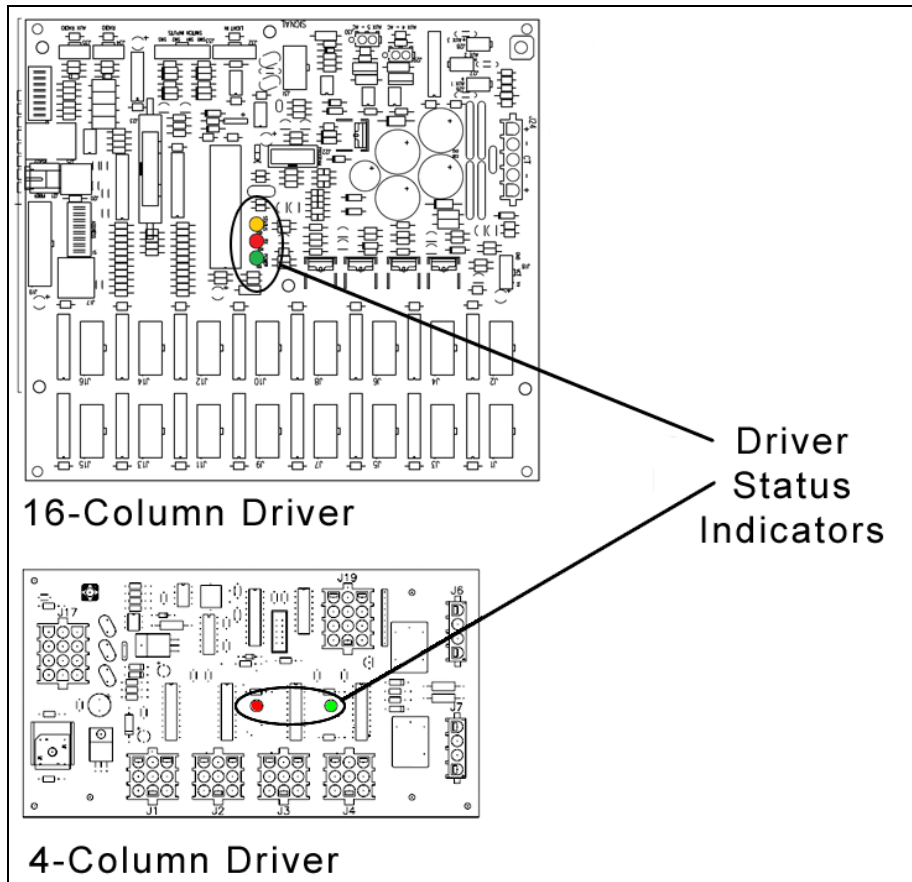

Figure 16: Driver Status Indicators

Replacing a Driver

If the driver status indicators do not appear to be working correctly, it may be necessary to replace the driver.

1. Open the digit panel or scoreboard face panel as described in **Section 5.2**.
2. Disconnect all connectors from the driver by squeezing together the locking tabs and pulling the connectors free.

Note: It may be helpful to label the cables to know which cable goes to which connector when reattaching the driver.

3. Remove the wing nuts securing the driver to the driver tray.
4. Carefully lift the driver from the display and place it on a clean, flat surface.
5. Position a new driver over the screws and tighten the nuts.
6. Reconnect all power/signal connectors.

Note: The connectors are keyed and will attach in one way only. Do not attempt to force the connections.

7. Ensure the driver is set to the correct address (refer to **Setting the Driver Address**).
8. Close and secure the access panel, then power up and test the scoreboard to see if changing the driver has resolved the problem.

Setting the Driver Address

Since the same LED drivers can be used for many scoreboard models, each driver must be set to receive the correct signal input, or address, for the model being used. Addresses are set through the S1 DIP switch on the driver (**Figure 17**) using a pen or small, pointed object.

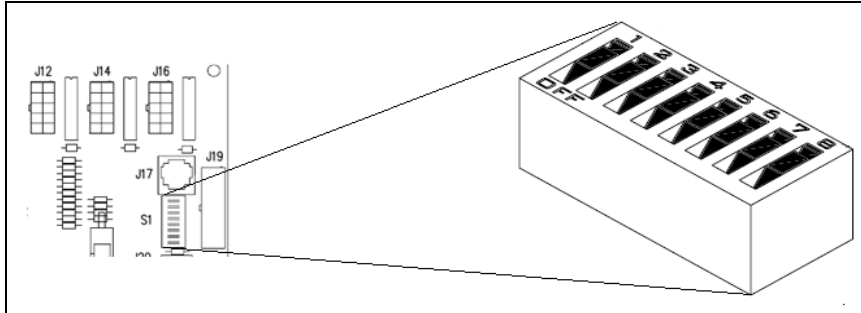

Figure 17: Driver Address DIP Switch (ColorSmart Driver)

When setting the driver address, first refer to the specifications table in **Section 2** to find the correct driver address(es) for a particular scoreboard model. Then refer to **Drawing A-284772 in Appendix E** for addressing information for driver addresses 1 - 128.

ColorSmart and 4-column LED drivers also have the option of setting the address using jumper wires in a 12- or 16 pin plug which mates with jack J19 on the driver (**Figure 18**). It may be possible to reuse the same address plug from the driver that was replaced. If not, first refer to the specifications table in **Section 2** to find the correct driver address(es) for a particular scoreboard model. Then refer to **Drawing A-284771 in Appendix E** for a listing of the wire/pin connections for driver addresses 1 - 128 for ColorSmart drivers, or refer to **Drawing A-115078** for 4-column LED drivers.

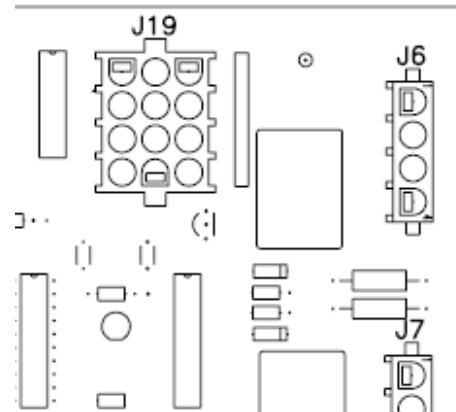

Figure 18: J19 Address (4-Column Driver)

5.5 Segmentation and Digit Designation

In each digit, certain LEDs always go on and off together. These groupings of LEDs are called segments. **Drawing A-38532** and **Drawing A-308053 in Appendix E** details which connector pin is wired to each digit segment and the wiring color code used throughout the display.

The electrical and signal specification drawings in **Appendix B** specify the driver connectors controlling the digits. Numbers shown in hexagons in the upper half of each digit indicate which connector is wired to that digit.

5.6 Schematics

For advanced scoreboard troubleshooting and repair, it may be necessary to consult the schematic drawings. These drawings, located in **Appendix D**, show detailed power and signal wiring diagrams of internal display components such as drivers, horn interface cards, and transformers as well as optional components like TNMCs, radio receivers, and end of period (EOP) lighting.

5.7 Replacement Parts List

Refer to the following table for Daktronics scoreboard replacement parts.

Description	Daktronics Part #
Horn, 120V with capacitor	0A-1152-0332
Main clock, start/stop switch	0A-1166-0003
Shot clock, start/stop switch	0A-1196-0031
LED driver, MCAST, 16-column	0P-1388-0100
LED driver, MCAST, 4-column	0P-1388-0101
Digit, 13" UniView, red LED, 7-seg	0P-1230-0027
Digit, 7" ColorSmart, red LED, 7-seg	0P-1388-0018
Digit, 7" ColorSmart, amber LED, 7-seg	0P-1388-0020
Digit, 7" ColorSmart, multicolor LED, 7-seg	0P-1388-0017
Digit, 7" ColorSmart, red LED, 2-seg	0P-1388-0030
Digit, 7" ColorSmart, amber LED, 2-seg	0P-1388-0032
Digit, 7" ColorSmart, multicolor LED, 2-seg	0P-1388-0029
Digit, 10" ColorSmart, red LED, 7-seg	0P-1388-0303
Digit, 10" ColorSmart, amber LED, 7-seg	0P-1388-0304
Digit, 10" ColorSmart, multicolor LED, 7-seg	0P-1388-0302
Digit, 10" ColorSmart, red LED, 2-seg	0P-1388-0307
Digit, 10" ColorSmart, amber LED, 2-seg	0P-1388-0308
Digit, 10" ColorSmart, multicolor LED, 2-seg	0P-1388-0306
Digit, 13" ColorSmart, red LED, 7-seg	0P-1388-0311
Digit, 13" ColorSmart, amber LED, 7-seg	0P-1388-0312
Digit, 13" ColorSmart, multicolor LED, 7-seg	0P-1388-0310
Digit, 13" ColorSmart, red LED, 2-seg	0P-1388-0315
Digit, 13" ColorSmart, amber LED, 2-seg	0P-1388-0316
Digit, 13" ColorSmart, multicolor LED, 2-seg	0P-1388-0314
Colon, 1 pos red LED	0P-1388-0319
Colon, 1 pos amber LED	0P-1388-0320
Colon, 1 pos multicolor LED	0P-1388-0318
Indicator, 1 pos red LED	0P-1388-0025
Indicator, 1 pos amber LED	0P-1388-0026
Indicator, 3 pos amber/red	0P-1388-0027
Power supply, 12V, 85-264VAC, 150W	A-2855
Transformer, 115/230 V @ 2 A	T-1063
Transformer, 115/230 V @ 6.25 A	T-1066
Transformer, 115/230 V @ 3 A (prior to 12/12)	T-1082
Cable, 20' phone plug	W-1236
Cable, 50' phone plug	W-1237
Cable, 30' phone plug	W-1238
Cable, 10' phone plug	W-1340

5.8 Daktronics Exchange and Repair & Return Programs

Exchange Program

The Daktronics Exchange Program is a service for quickly replacing key components in need of repair. If a component fails, Daktronics sends a replacement part to the customer who, in turn, returns the failed component to Daktronics. This decreases equipment downtime. Customers who follow the program guidelines explained below will receive this service.

Before Contacting Daktronics

Identify these important numbers:

Display Serial Number: _____

Display Model Number: _____

Job/Contract Number: _____

Date Installed: _____

Daktronics Customer ID Number: _____

To participate in the Exchange Program, follow these steps.

1. Call Daktronics Customer Service.

Market Description	Customer Service Number
Schools (including community/junior colleges), religious organizations, municipal clubs and community centers	877-605-1115
Universities and professional sporting events, live events for auditoriums and arenas	866-343-6018

2. When the new exchange part is received, mail the old part to Daktronics.

If the replacement part fixes the problem, send in the problem part being replaced.

- a. Package the old part in the same shipping materials in which the replacement part arrived.
- b. Fill out and attach the enclosed UPS shipping document.
- c. Ship the part to Daktronics.

3. The defective or unused parts must be returned to Daktronics within 5 weeks of initial order shipment.

If any part is not returned within five (5) weeks, a non-refundable invoice will be presented to the customer for the costs of replenishing the exchange parts inventory with a new part.

Daktronics reserves the right to refuse parts that have been damaged due to acts of nature or causes other than normal wear and tear.

Repair & Return Program

For items not subject to exchange, Daktronics offers a Repair & Return Program. To send a part for repair, follow these steps:

1. **Call or fax Daktronics Customer Service:**
Refer to the appropriate market number in the chart listed on the previous page.
Fax: 605-697-4444
2. **Receive a case number before shipping.**
This expedites repair of the part.
3. **Package and pad the item carefully to prevent damage during shipment.**
Electronic components, such as printed circuit boards, should be placed in an antistatic bag before boxing. Daktronics does not recommend using packing 'peanuts' when shipping.
4. **Enclose:**
 - name
 - address
 - phone number
 - the case number
 - a clear description of symptoms

Shipping Address

Daktronics Customer Service
[Case #]
201 Daktronics Drive, Dock E
Brookings, SD 57006

Daktronics Warranty and Limitation of Liability

The Daktronics Warranty and Limitation of Liability is located in **Appendix F**. The Warranty is independent of Extended Service agreements and is the authority in matters of service, repair, and display operation.

Section 6: Scoreboard Options

6.1 Horns

Daktronics ColorSmart scoreboards are equipped with a 120 VAC vibrating horn mounted behind the scoreboard face. The horn sounds automatically when the period clock counts down to zero, or when manually triggered by the operator using the control console.

Installation of an optional 12 VDC horn is detailed in **Drawing A-148960** in **Appendix C**. Louder trumpet horns are also available. Contact Daktronics for information and pricing.

Adjusting Horn Volume

CAUTION: The scoreboard horn is a 120 VAC device. Turn off the power to the scoreboard before adjusting the horn.

The volume for the electronic, buzzer-type horn is set at its maximum level at the factory. If the horn is too loud, reduce its volume by adjusting the setscrew mounted in the front of the horn. A plastic tip on the screw touches the horn's diaphragm, reducing the volume. Turn the screw clockwise and test the volume by operating the horn from the scoreboard control console. Continue adjusting and testing until the desired volume level is obtained.

Note that with the noise of spectators, the horn will not seem as loud as when it is being tested in an empty area, so be sure to set the volume according to the acoustics of the facility.

6.2 Radio Control

Radio control is an option for Daktronics ColorSmart scoreboards. The system provides scoreboard control via a 2.4 GHz, extra-high frequency FM signal.

The radio transmitter and receiver are not standard equipment. This setup requires a control console equipped with a radio transmitter as well as a radio receiver plugged into the driver/power enclosure and mounted internally to the front panel of the scoreboard.

For additional information about this option, contact a Daktronics representative; for complete information on setting up radio communication control, refer to the **Gen V Radio Installation Manual (ED-13831)** or the **Gen VI Radio Installation Manual (DD2362277)**, both available online at www.daktronics.com/manuals.

6.3 Visual Horn Indicator (VHI)

In addition to the horn, Daktronics offers a visual horn indicator (VHI) that lights up when the buzzer sounds. To install a VHI, users must tap into the existing horn wiring to provide power and signal. For more information about installing the VHI option, including details on the inputs, outputs, and switches of a shot clock relay board that controls when the VHI should be turned on, refer to the **VHI (ED-13397)** or **BB-2133 (ED-13806) Installation Instructions**, both available online at www.daktronics.com/manuals.

6.4 Changeable Captions

Team name and statistics caption kits contain hardware for one caption only and consist of an upper caption retainer, a lower caption retainer, a changeable caption panel and screws.

The standard HOME and GUEST captions are applied directly to the face of the scoreboard. Team name captions are on changeable panels that fit into retainers mounted above and below the standard captions. If these retainers are not already present, attach the retainers included with the caption kit.

Caption kits are also available for certain statistics display models to switch between basketball, volleyball, wrestling, and hockey modes.

Refer to **Drawing A-150021** in **Appendix C** for changeable caption installation instructions.

6.5 Time Outs Left (TOL) Digits

The BB-3103 scoreboard has the option to add a time outs left (TOL) digit for both the home and guest teams. These digits are installed by simply unscrewing the blank face panel, connecting and securing the digit, and applying the "T.O.L." caption. Refer to **Drawing A-149030** in **Appendix C** for more information.

6.6 Double Bonus Indicators

All of the clock/score basketball scoreboards in this manual have the option to include double-bonus indicators, which are factory installed. This option is illustrated in the electrical and signal specification drawings in **Appendix B** for each scoreboard model.

6.7 Team Name Message Centers & Electronic Captions

Refer to **Section 7** for more information about Team Name Message Centers and electronic captions.

Section 7: TNMC & Electronic Caption Troubleshooting & Maintenance

IMPORTANT NOTES:

1. Always disconnect scoreboard power before doing any repair/maintenance work on the message centers.
2. Permit only qualified service personnel to access internal display electronics.
3. Disconnect power when not using the scoreboard.

7.1 Display Overview

Team Name Message Centers (TNMCs) are programmable LED displays that allow users to show custom Home and Guest names or messages of ~15 characters on the scoreboard in place of static vinyl captions. TNMCs are typically ordered factory-installed, but they may also be field-mounted after the scoreboard is in place. Characters are shown on one line using single- or double-stroke fonts.

Electronic captions, on the other hand, are pre-programmed to only show specific labels to match the captions for a particular sport mode, making it much simpler to switch between sports. Characters are shown on one line using single-stroke fonts.

Primary matrix size is 8x48 with 0.75" pixel spacing. **Figure 19** shows examples of both TNMCs and electronic captions.



Figure 19: Basketball Scoreboard with TNMCs and Electronic Captions

Matrix Size	Number of Modules	Pixel Spacing	Active Display Area	Weight*
8x48	3	19 mm (0.75")	6" x 36" (152 mm x 914 mm)	15 lb (7 kg)

*Weight shown is for a pair of displays.

7.2 Initialization Information at Startup

Every time the display is powered up and there is no All Sport® signal present, the display will run through an initialization process, during which it will test all LEDs and addresses. First, the message center will display the proper address number.

If the entire display fails at startup, power may not be properly connected, or the address setting may not be correct on the display driver. Check both in the event of a failure.

7.3 Display Troubleshooting Table

The table below lists potential problems with the display and indicates possible causes and corrective actions. This list does not include every symptom that may be encountered, but it does present several of the most common situations that may occur.

Many of the solutions offered below provide references to other sections within this manual with further detail on how to fix the problem.

If a problem occurs that is not listed or that cannot be resolved using the solutions in the following table, contact Daktronics using the information provided in **Section 5.8**.

Symptom/Condition	Possible Remedy
One or more LEDs on a single module fails to light	Check/replace the ribbon cables on the module.
	Replace the module (see Section 7.6).
One or more LEDs on a single module fails to turn off	Check/replace the ribbon cables on module.
	Replace the module (see Section 7.6).
A section of the display not working; section extends all the way to the right side of the display	Check/replace the ribbon cables running to the first module that is not working.
	Replace the first module on the left side of the first module that is not working (see Section 7.6).
	Replace the second module that is not working (see Section 7.6).
	Replace the power supply assembly on the first module that is not working (see Section 7.7).
One row of modules does not work or is garbled	Replace the first module (see Section 7.6).
A group of modules that share the same power supply assembly fails to work	Replace the power supply assembly (see Section 7.7).
Entire display fails to work	Check for proper line voltage into the power termination panel.
	Check/replace the ribbon cable from the display driver to the modules.
	Check the voltage settings on the power supplies.
	Check/replace the signal cable to the driver.

7.4 Power & Signal Summary

Reference Drawings:

Address Table; Driver- MCAST- TNMC DIP Switch	Drawing A-284773
Schematic: Multicast TNMC 3/4" (.75)	Drawing B-296394

Refer to **Drawing B-296394** in **Appendix D** for detailed schematics about display power and signal routing.

Display signal routing can be summarized as follows:

1. Data from the All Sport[®] controller travels via signal cable (or radio) into the scoreboard.
2. The signal then travels through the driver and out to the first LED module of the Home display via ribbon cable harness.
3. The signal relays from module to module via ribbon cable in daisy-chain style until it reaches the last module in the Guest display. In electronic captions, the Home and Guest displays receive signal from separate drivers.

Display power routing can be summarized as follows:

1. Incoming power from the power cord terminates at the main scoreboard LED driver tray.
2. Using interconnect harnesses, the power for TNMCs is passed from the driver tray to the Home display power supply, and then to the Guest display power supply.
In electronic captions, each power supply receives power from a separate driver.
3. Power from the power supplies is relayed to all display modules.
4. The modules draw their power directly from the power supply assemblies.

The S2 DIP switch package on the main scoreboard driver sets the display driver address.

Refer to **Drawing A-284773** in **Appendix E** for the location and functions of the S2 DIP switch.

- For TNMCs, switches 1-4 of S2 are set to OFF, which equals address 221. With Switch 5 off, Home information is displayed. With Switch 5 on, Guest information is displayed.
- For electronic captions, a typical Player-Foul-Points display uses address 223, with Switch 2 and Switch 5 both on.

7.5 Component Locations & Access

Reference Drawings:

Installation- MCAST- 6" Amber 8x48 TNMC.....	Drawing A-296610
Installation: Programmable Caption- 8x48-6"- MCAST	Drawing A-324099

To access the internal components of the display, simply remove the two screws on either side of the face panel that secure it to the scoreboard. Carefully remove the face panel from the scoreboard, as there will be several cables connected to it.

Drawing A-296610 and **Drawing A-324099** in **Appendix C** provide a detailed view of each display component and the connections between them.

7.6 Modules

Display modules consist of LEDs embedded in a circuit board. One or more circuit boards are mounted to the back of a display face panel. Do not attempt to remove individual LEDs. In the case of malfunctioning LEDs, replace the entire module circuit board.

Replacing Modules

1. Access the internal components as described in **Section 7.5**.
2. Carefully disconnect all ribbon cables from the driver by squeezing together the locking tabs and pulling the connectors free.

Note: It may be helpful to label the cables to know which cable goes to which connector when reattaching.

3. Remove the nuts securing the module circuit board to the face panel.
4. Position a new module on the front of the face panel and reconnect all ribbon cables.
5. Reattach the module to the face panel.
6. Power up and test the scoreboard/display to see if the problem has been resolved.

Refer to **Figure 20** for an overview of module (and driver) replacement.

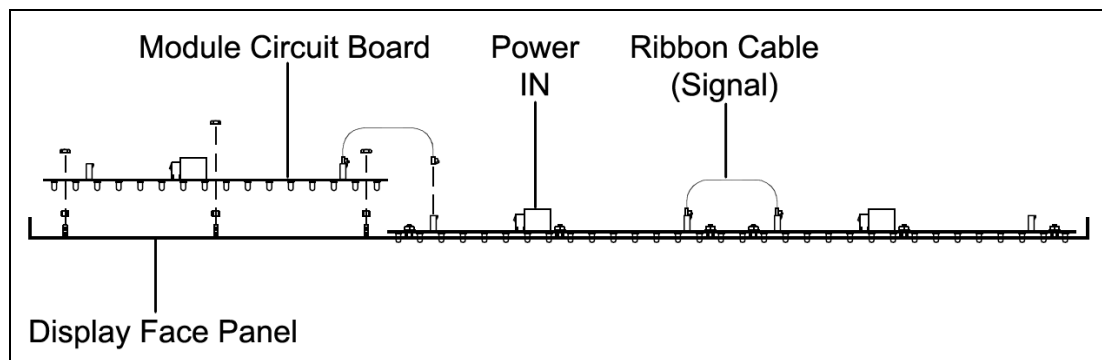

Figure 20: Replacing a Module, Top View

7.7 Power Supplies

Replacing a Power Supply

1. Access the internal components as described in **Section 7.5**.
2. Remove the two screws securing the power supply bracket, and remove it from the display cabinet.
3. Disconnect all the wires connected to the power supply.

Note: It may be helpful to label the cables to know which cable goes to which connector when reattaching.

4. Remove the three screws securing the power supply to the bracket, and attach the new power supply to it.
5. Reconnect all wires, and mount the power supply bracket inside the display cabinet.

7.8 Display Maintenance

Complete a yearly inspection to maintain safe and dependable display operation. This inspection should address the following issues:

- **Loose Hardware:** Verify that fasteners, such as bolts and rivets, have not come loose. Check and tighten or replace fasteners as required.
- **Excessive Dust Buildup:** It may be necessary to occasionally vacuum the inside of the display cabinet to remove dust/dirt buildup that may interfere with airflow.
- **Corrosion:** Check the paint, and look for possible corrosion

Note: If any of the preceding conditions are discovered, make the necessary repairs or take corrective action immediately.

7.9 Replacement Parts List

The following table contains display components that may have to be replaced. Many of the components within the display itself have attached part number labels.

Part Description	Part Number
Module; 8x16, Amber	0P-1186-0112
Power Supply; 5V @ 10A, 85-264VAC	A-1568
Cable; 18 pos, Ribbon, 6"	W-1320

See **Section 5.8** for information on Daktronics Exchange and Repair and Return program.

Appendix A: Mechanical Specification Drawings

<i>Drawing Title</i>	<i>Drawing Number</i>
Mechanical Spec- MCAST- BB-3101	A-282951
Mechanical Spec- MCAST- BB-3103	A-282953
Mechanical Spec- MCAST- BB-3105	A-282955
Mechanical Spec- MCAST- BB-3107	A-282957
Mechanical Spec- MCAST- BB-3114	A-282959
Mechanical Spec- MCAST- BB-3115	A-282961
Mechanical Spec- MCAST- BB-3121	A-282963
Mechanical Spec- MCAST- SD-3101	A-282965
Mechanical Spec- MCAST- SD-3102	A-282967
Mechanical Spec- MCAST- SD-3103	A-282969
Mechanical Spec, MCAST-BB-3142.....	A-956971
Mechanical Spec, MCAST-BB-3125.....	A-957066
Mechanical Spec; BB-3123	A-1065737

BB-3101

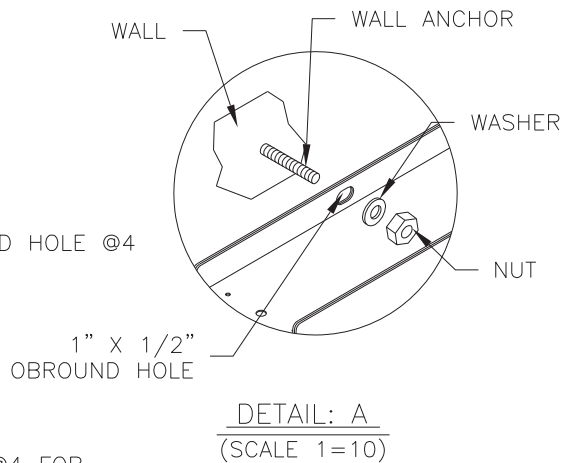
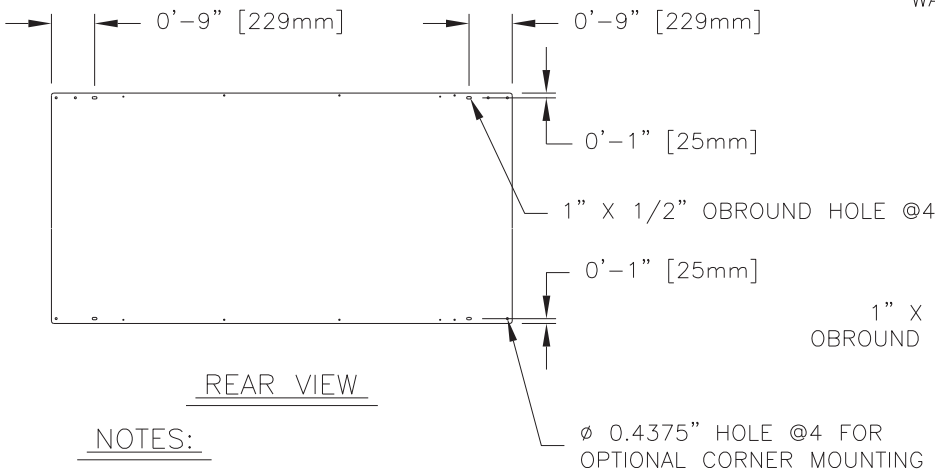
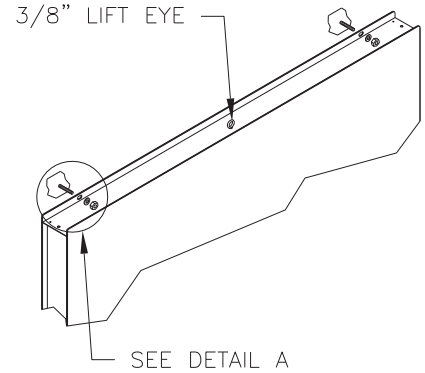
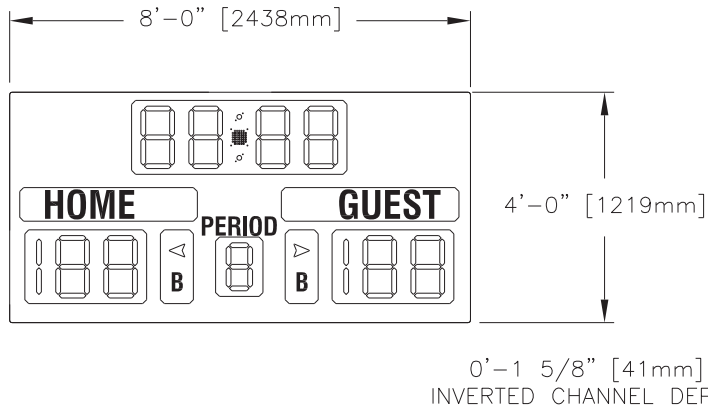
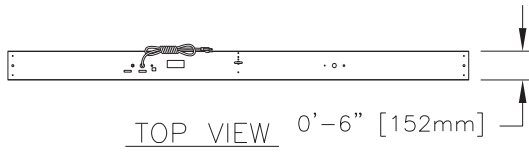

1. USE APPROPRIATE WALL ANCHORS FOR TYPE OF WALL.
2. LIFT EYE IS FOR TEMPORARY USE WHILE LIFTING SCOREBOARD DURING INSTALLATION. DO NOT USE LIFT EYE FOR PERMANENT SUSPENSION.
3. SEE DRAWING 1237-R10A-148644 FOR OPTIONAL PERMANENT SUSPENSION OF THE SCOREBOARD.
4. THE SCOREBOARD IS SHOWN WITH UNIVIEW™ DIGIT TECHNOLOGY. SEE DRAWING A-158550 FOR MORE DETAILS.

WEIGHTS	
SHIPPING WEIGHT	MOUNTING WEIGHT
192 LBS (87 KG)	120 LBS (55 KG)

TUFF SPORT™ & COLORSMART™ ARE TRADEMARKS OF DAKTRONICS

THE CONCEPTS EXPRESSED AND DETAILS SHOWN ON THIS DRAWING ARE CONFIDENTIAL AND PROPRIETARY. DO NOT REPRODUCE BY ANY MEANS, INCLUDING ELECTRONICALLY WITHOUT THE EXPRESSED WRITTEN CONSENT OF DAKTRONICS, INC. COPYRIGHT 2006 DAKTRONICS, INC.

DAKTRONICS, INC. BROOKINGS, SD 57006

PROJ: TUFF SPORT™ COLORSMART™ SCOREBOARDS

TITLE: MECHANICAL SPEC- MCAST- BB-3101

DES. BY: JFELDHA

DRAWN BY: JFELDHA

DATE: 21 AUG 06

REV.	DATE	DESCRIPTION	BY	APPR.
00				

REVISION	APPR. BY:
00	SCALE: 1=40

1389-E10A-282951

BB-3103

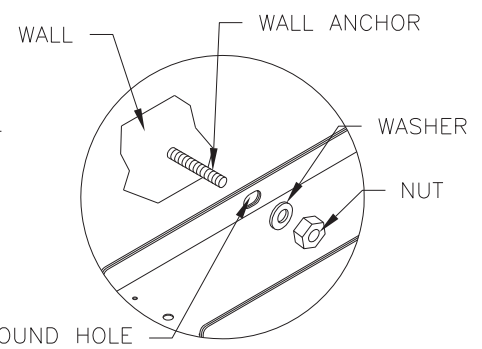
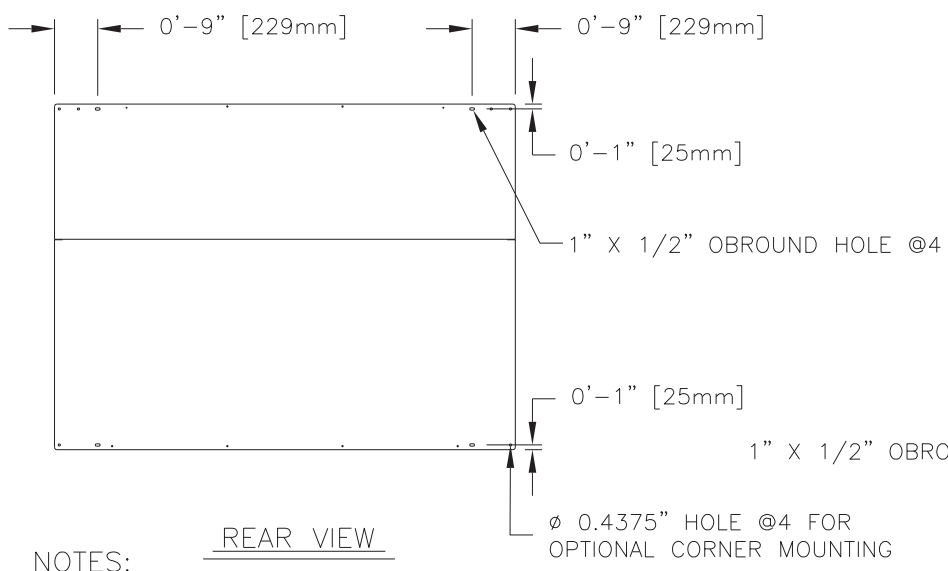
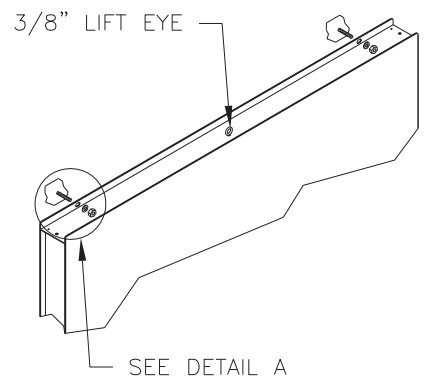
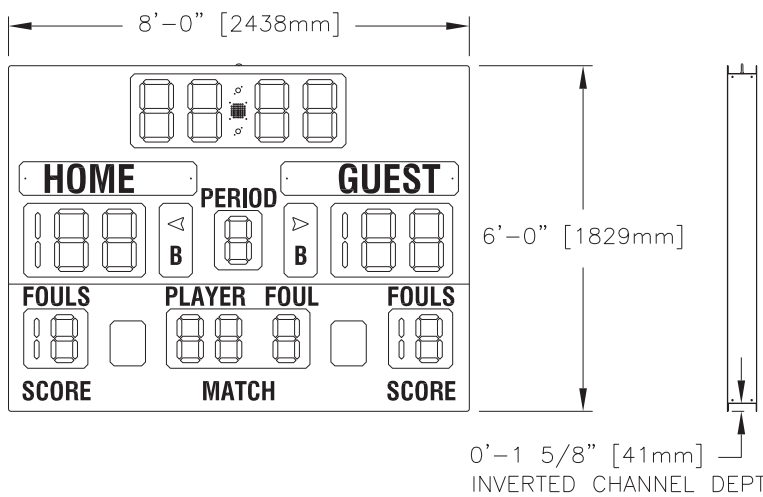
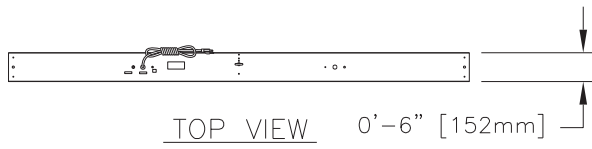

DETAIL: A
(SCALE 1=10)

NOTES:

1. USE APPROPRIATE WALL ANCHORS FOR TYPE OF WALL.
2. LIFT EYE IS FOR TEMPORARY USE WHILE LIFTING SCOREBOARD DURING INSTALLATION. DO NOT USE LIFT EYE FOR PERMANENT SUSPENSION.
3. SEE DRAWING 1237-R10A-148644 FOR OPTIONAL PERMANENT SUSPENSION OF THE SCOREBOARD.
4. THE SCOREBOARD IS SHOWN WITH UNIVIEW™ DIGIT TECHNOLOGY. SEE DRAWING A-158550 FOR MORE DETAILS.

WEIGHTS	
SHIPPING WEIGHT	MOUNTING WEIGHT
290 LBS (132 KG)	180 LBS (82 KG)

TUFF SPORT™, COLORSMART™ & UNIVIEW™ ARE TRADEMARKS OF DAKTRONICS

THE CONCEPTS EXPRESSED AND DETAILS SHOWN ON THIS DRAWING ARE CONFIDENTIAL AND PROPRIETARY. DO NOT REPRODUCE BY ANY MEANS, INCLUDING ELECTRONICALLY WITHOUT THE EXPRESSED WRITTEN CONSENT OF DAKTRONICS, INC. COPYRIGHT 2006 DAKTRONICS, INC.

DAKTRONICS, INC. BROOKINGS, SD 57006

PROJ: TUFFSPORT™ COLORSMART™ SCOREBOARDS

TITLE: MECHANICAL SPEC- MCAST- BB-3103

DES. BY: JFELDHA

DRAWN BY: JFELDHA

DATE: 21 AUG 06

REVISION
00

APPR. BY:
SCALE: 1=40

1389-E10A-282953

REV.	DATE	DESCRIPTION	BY	APPR.

BB-3105

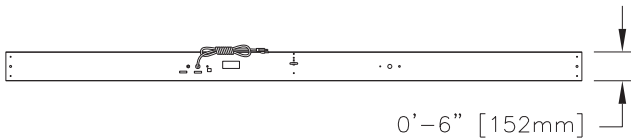

TOP VIEW

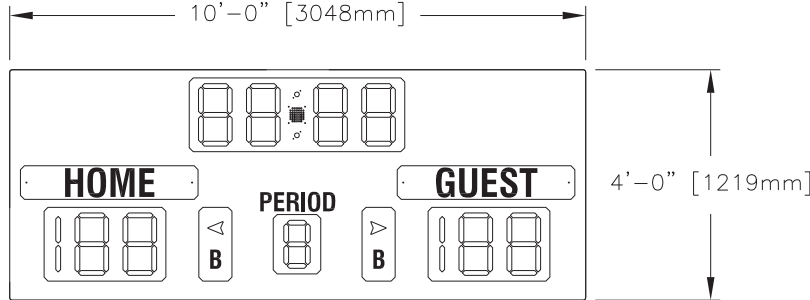

FRONT VIEW

0'-1 5/8" [41mm]
INVERTED CHANNEL DEPTH

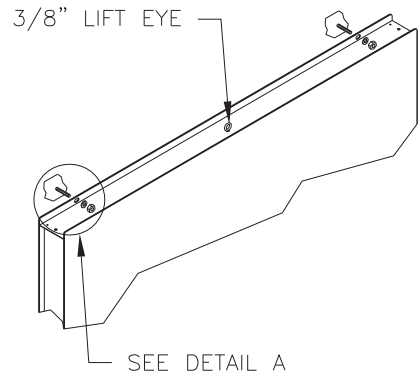

WALL MOUNTING DETAIL

SIDE VIEW



BOTTOM VIEW

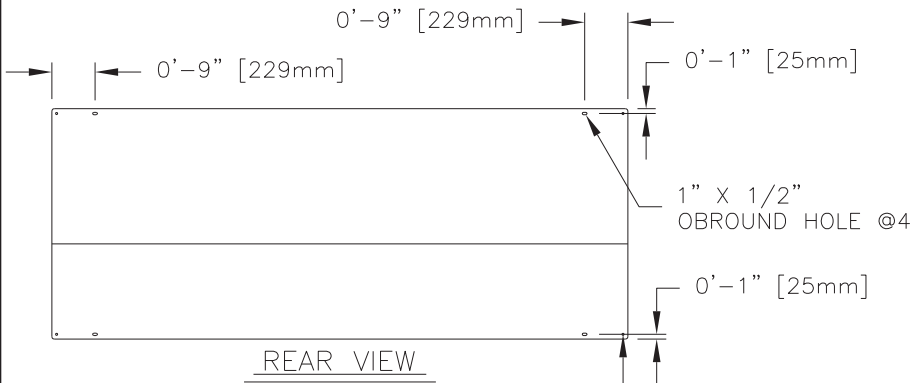

REAR VIEW

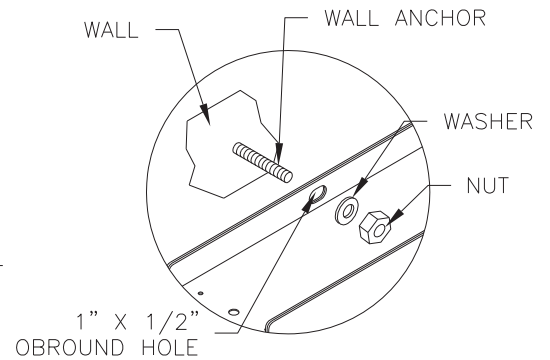

DETAIL: A
(SCALE 1=10)

NOTES:

1. USE APPROPRIATE WALL ANCHORS FOR TYPE OF WALL.
2. LIFT EYE IS FOR TEMPORARY USE WHILE LIFTING SCOREBOARD DURING INSTALLATION. DO NOT USE LIFT EYE FOR PERMANENT SUSPENSION.
3. SEE DRAWING 1237-R10A-148644 FOR OPTIONAL PERMANENT SUSPENSION OF THE SCOREBOARD.
4. THE SCOREBOARD IS SHOWN WITH UNIVIEW™ DIGIT TECHNOLOGY. SEE DRAWING A-158550 FOR MORE DETAILS™

WEIGHTS

SHIPPING WEIGHT	MOUNTING WEIGHT
240 LBS (109 KG)	150 LBS (68 KG)

TUFF SPORT™, COLORSMART™ & UNIVIEW™ ARE TRADEMARKS OF DAKTRONICS

THE CONCEPTS EXPRESSED AND DETAILS SHOWN ON THIS DRAWING ARE CONFIDENTIAL AND PROPRIETARY. DO NOT REPRODUCE BY ANY MEANS, INCLUDING ELECTRONICALLY WITHOUT THE EXPRESSED WRITTEN CONSENT OF DAKTRONICS, INC. COPYRIGHT 2006 DAKTRONICS, INC.

DAKTRONICS, INC. BROOKINGS, SD 57006

PROJ: TUFFSPORT™ COLORSMART™ SCOREBOARDS

TITLE: MECHANICAL SPEC- MCAST- BB-3105

DES. BY: JFELDHA

DRAWN BY: JFELDHA

DATE: 21 AUG 06

REV.	DATE	DESCRIPTION	BY	APPR.
00				

REVISION	APPR. BY:
00	SCALE: 1=40

1389-E10A-282955

BB-3107

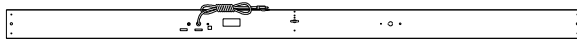

0'-6" [152mm]

TOP VIEW

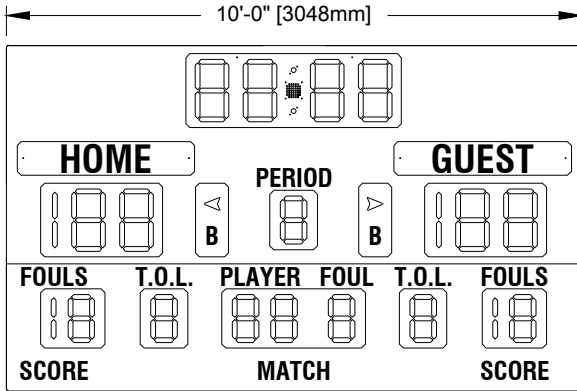

FRONT VIEW

6'-0" [1829mm]

0'-1 5/8" [41mm]
INVERTED CHANNEL DEPTH

SIDE VIEW

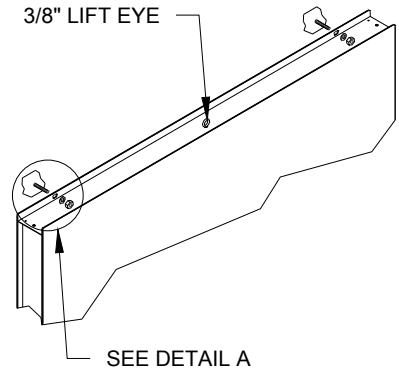

WALL MOUNTING DETAIL

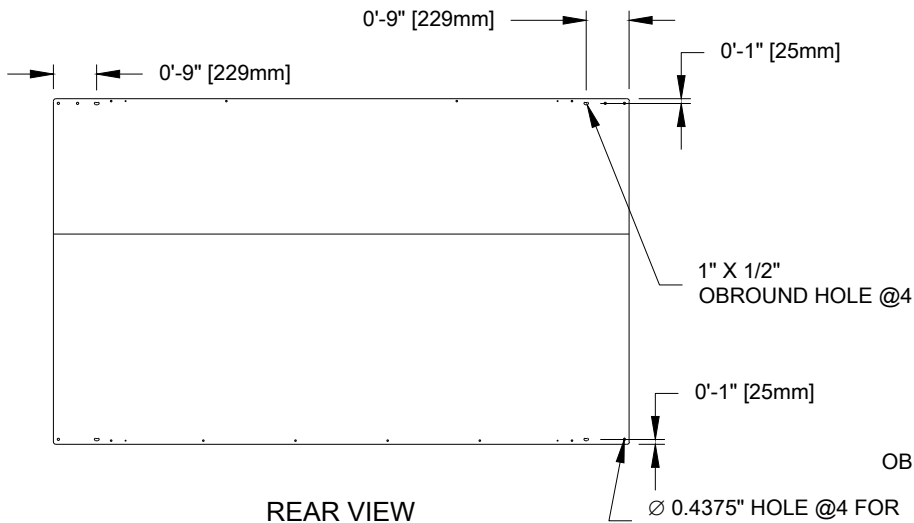

REAR VIEW

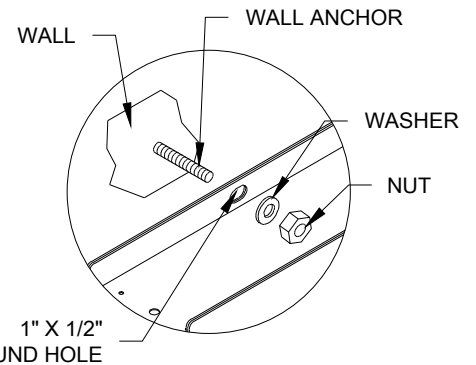

DETAIL: A
(SCALE 1=10)

NOTES:

1. USE APPROPRIATE WALL ANCHORS FOR TYPE OF WALL.
2. LIFT EYE IS FOR TEMPORARY USE WHILE LIFTING SCOREBOARD DURING INSTALLATION. DO NOT USE LIFT EYE FOR PERMANENT SUSPENSION.
3. SEE DRAWING 1237-R10A-148644 FOR OPTIONAL PERMANENT SUSPENSION OF THE SCOREBOARD.
4. THE SCOREBOARD IS SHOWN WITH UNIVIEW™ DIGIT TECHNOLOGY. SEE DRAWING A-158550 FOR MORE DETAILS.

WEIGHTS

SHIPPING WEIGHT	MOUNTING WEIGHT
395 LBS (179 KG)	260 LBS (118 KG)

TUFFSPORT™, COLORSMART™ & UNIVIEW™ ARE TRADEMARKS OF DAKTRONICS

 DAKTRONICS, INC. BROOKINGS, SD 57006	THE CONCEPTS EXPRESSED AND DETAILS SHOWN ON THIS DRAWING ARE CONFIDENTIAL AND PROPRIETARY. DO NOT REPRODUCE BY ANY MEANS WITHOUT THE EXPRESSED WRITTEN CONSENT OF DAKTRONICS, INC. COPYRIGHT 2013 DAKTRONICS, INC.	
	DO NOT SCALE DRAWING	
PROJ: TUFFSPORT COLORSMART SCOREBOARDS		
TITLE: MECHANICAL SPEC- MCAST- BB-3107		
DESIGN: JFELDHA	DRAWN: JFELDHA	DATE: 21 AUG 06
SCALE: 1=40		
SHEET	REV 01	JOB NO: P 1389
FUNC-TYPE-SIZE E - 10 - A		282957

REV 01	DATE: 14 JAN 13	UPDATED WEIGHTS	BY: KDD
-----------	--------------------	-----------------	------------

BB-3114

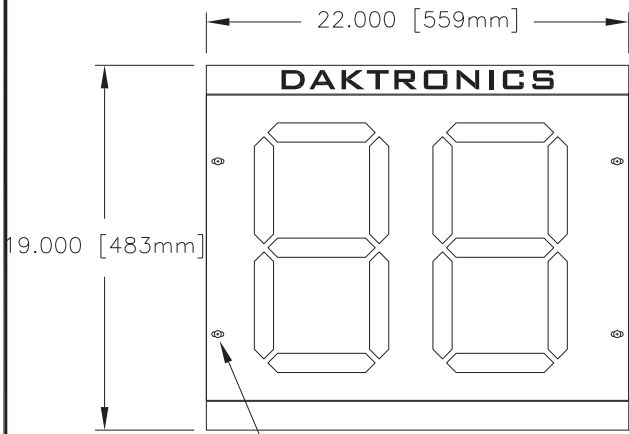

FRONT VIEW

REMOVE THESE FOUR SCREWS TO ACCESS COMPONENTS INSIDE THE DISPLAY.

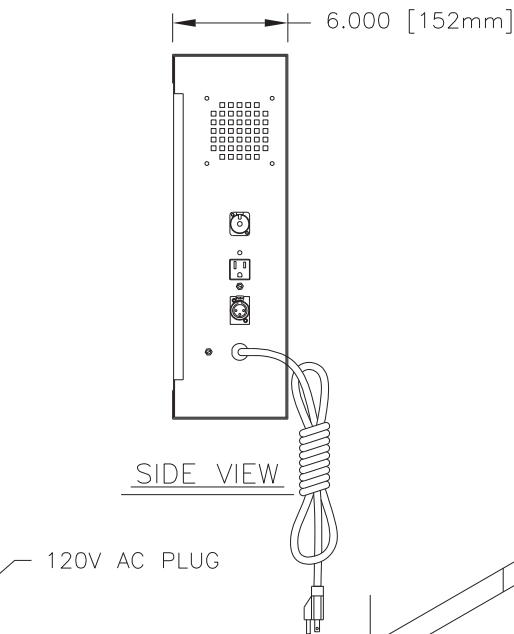

SIDE VIEW

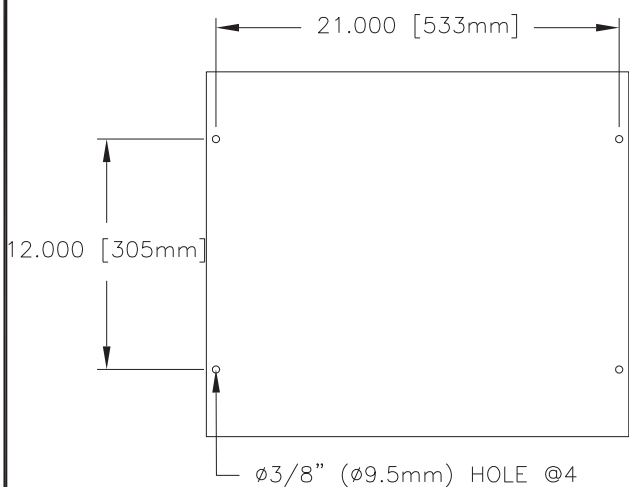

REAR VIEW

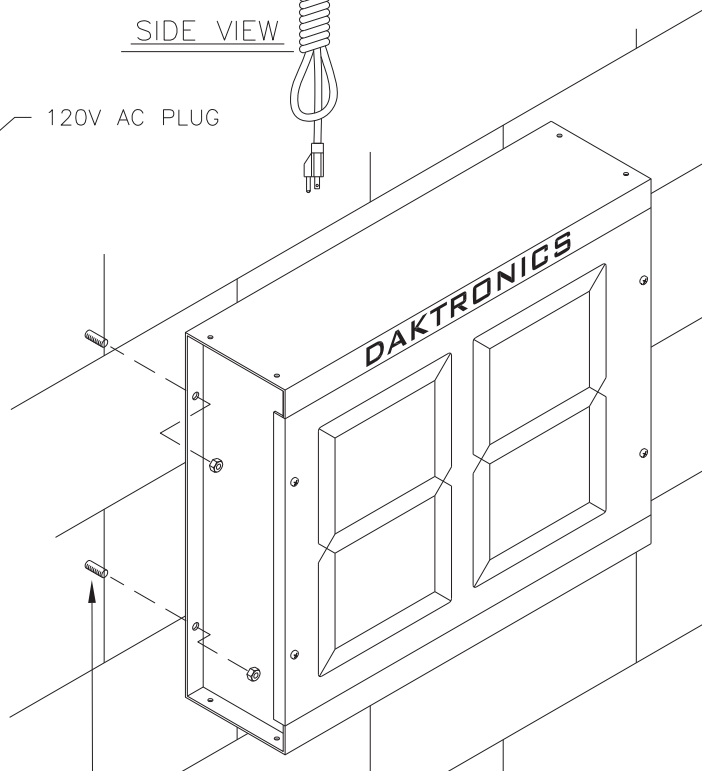

MOUNTING BOLTS (NOT PROVIDED)
USE 1/4" TO 3/8" (7mm TO 9mm) BOLTS

WALL MOUNTING DETAIL

NOTES:

1. MOUNTING HARDWARE IS NOT PROVIDED.
2. SEE DRAWING NO. 1009-R10A-91230 FOR SUGGESTIONS ON MOUNTING TO CEILING-SUSPENDED BACKSTOPS.
3. FOR PORTABLE BACKSTOPS, CONTACT THE BACKSTOP MANUFACTURER FOR MOUNTING HARDWARE.
4. THE SCOREBOARD IS SHOWN WITH UNIVIEW™ DIGIT TECHNOLOGY. SEE DRAWING A-158550 FOR MORE DETAILS.

WEIGHTS

SHIPPING WEIGHT	MOUNTING WEIGHT
20 LBS (10 KG)	15 LBS (7 KG)

TUFFSPORT™ COLORSMART™ & UNIVIEW™ ARE TRADEMARKS OF DAKTRONICS

THE CONCEPTS EXPRESSED AND DETAILS SHOWN ON THIS DRAWING ARE CONFIDENTIAL AND PROPRIETARY. DO NOT REPRODUCE BY ANY MEANS, INCLUDING ELECTRONICALLY WITHOUT THE EXPRESSED WRITTEN CONSENT OF DAKTRONICS, INC. COPYRIGHT 2006 DAKTRONICS, INC.			
DAKTRONICS, INC. BROOKINGS, SD 57006			
PROJ: TUFFSPORT™ COLORSMART™ SCOREBOARDS			
TITLE: MECHANICAL SPEC- MCAST- BB-3114			
DES. BY: JFELDHA		DRAWN BY: JFELDHA	
		DATE: 21 AUG 06	
REVISION	APPR. BY:	1389-E10A-282959	
00	SCALE: 1=10		

REV.	DATE	DESCRIPTION	BY	APPR.

BB-3115

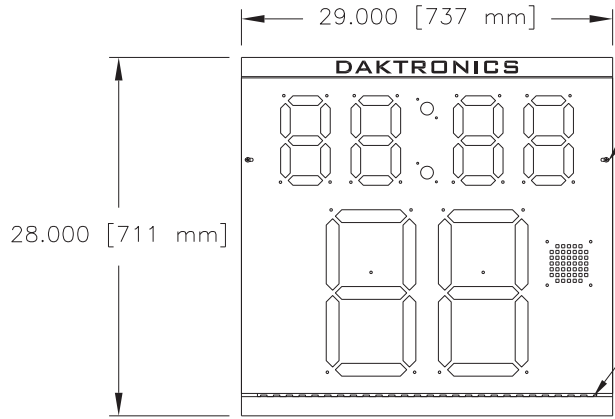

FRONT VIEW

REMOVE THE SCREWS
SECURING THE FACE PANEL
TO ACCESS INTERIOR

FACE PANEL IS MOUNTED
WITH A HINGE

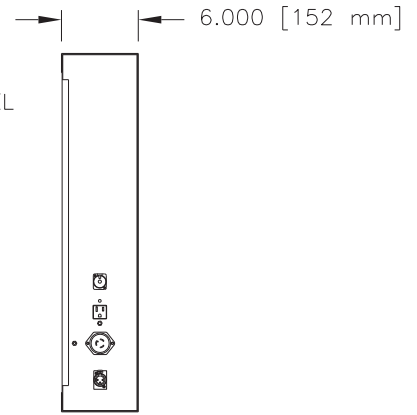

SIDE VIEW

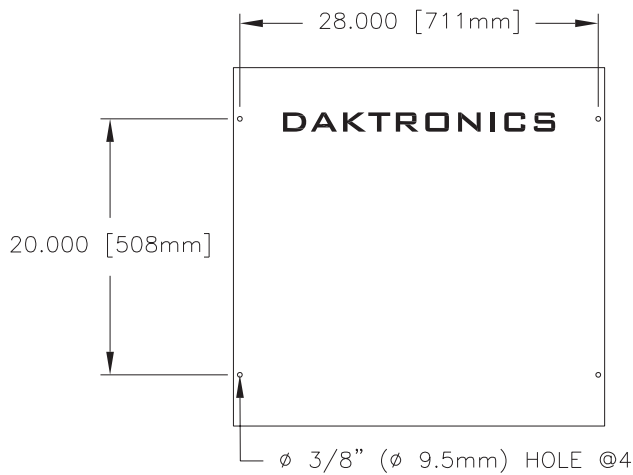

REAR VIEW

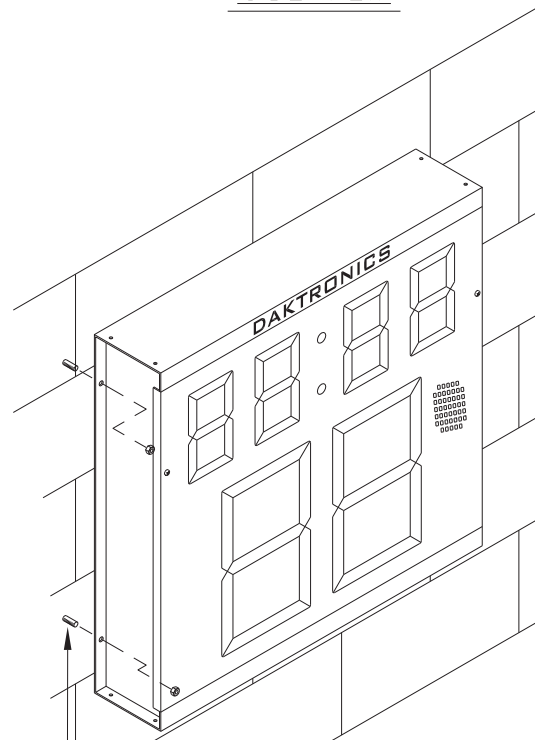

MOUNTING BOLTS (NOT PROVIDED)
USE 1/4" TO 3/8" (7mm TO 9mm) BOLTS

WALL MOUNTING DETAIL

NOTES:

1. MOUNTING HARDWARE IS NOT PROVIDED.
2. SEE DRAWING NO. 1009-R10A-91230 FOR SUGESTIONS ON MOUNTING TO CEILING-SUSPENDED BACKSTOPS.
3. FOR PORTABLE BACKSTOPS, CONTACT THE BACKSTOP MANUFACTURER FOR MOUNTING HARDWARE.
4. THE SCOREBOARD IS SHOWN WITH UNIVIEW DIGIT TECNOLOGY. SEE DWG A-158550 FOR MORE DETAILS.

WEIGHTS

SHIPPING WEIGHT	MOUNTING WEIGHT
40 LBS (18 KG)	30 LBS (14 KG)

TUFFSPORT™, COLORSMART™ & UNIVIEW™ ARE TRADEMARKS OF DAKTRONICS

THE CONCEPTS EXPRESSED AND DETAILS SHOWN ON THIS DRAWING ARE CONFIDENTIAL AND PROPRIETARY. DO NOT REPRODUCE BY ANY MEANS, INCLUDING ELECTRONICALLY WITHOUT THE EXPRESSED WRITTEN CONSENT OF DAKTRONICS, INC. COPYRIGHT 2006 DAKTRONICS, INC.

DAKTRONICS, INC. BROOKINGS, SD 57006

PROJ: TUFFSPORT™ COLORSMART™ SCOREBOARDS

TITLE: MECHANICAL SPEC- MCAST- BB-3115

DES. BY: JFELDHA

DRAWN BY: JFELDHA

DATE: 21 AUG 06

REV.	DATE	DESCRIPTION	BY	APPR.
00				

REVISION
00

APPR. BY:

SCALE: 1=15

1389-E10A-282961

BB-3121

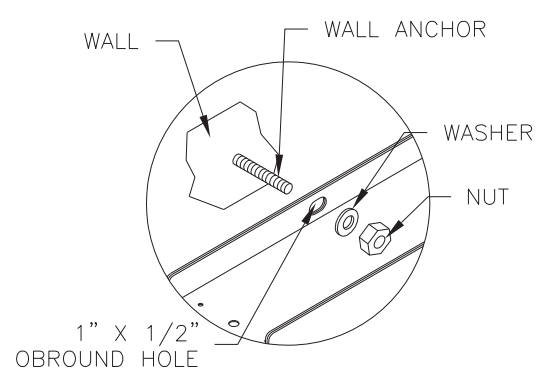
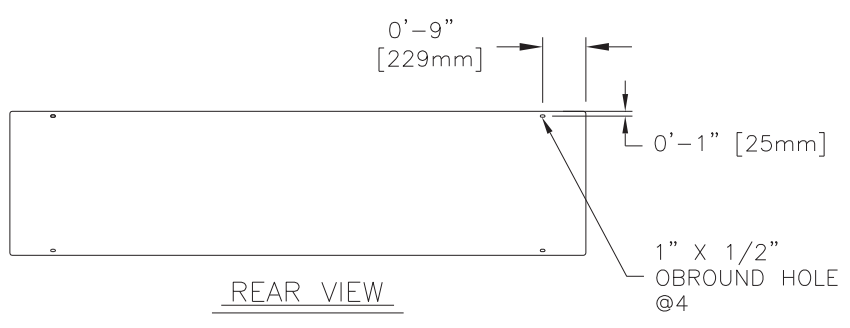
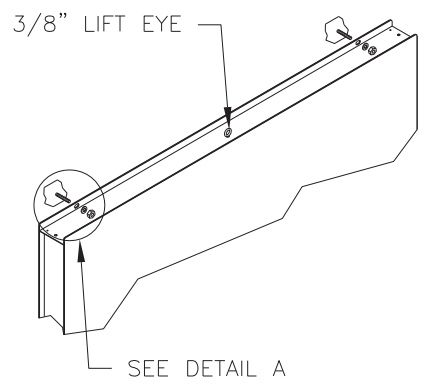
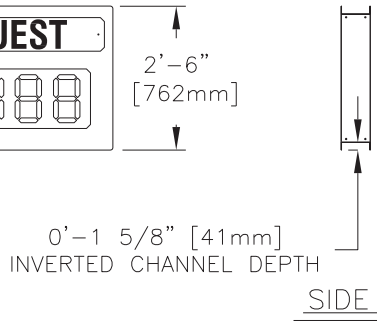
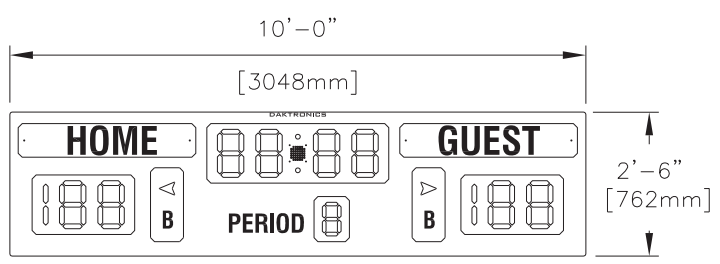
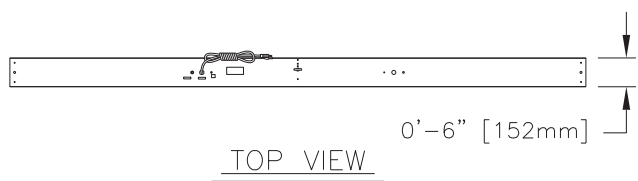

NOTES:

1. USE APPROPRIATE WALL ANCHORS FOR TYPE OF WALL.
2. LIFT EYE IS FOR TEMPORARY USE WHILE LIFTING SCOREBOARD DURING INSTALLATION. DO NOT USE LIFT EYE FOR PERMANENT SUSPENSION.
3. SEE DRAWING 1237-R10A-148644 FOR OPTIONAL PERMANENT SUSPENSION OF THE SCOREBOARD.
4. THE SCOREBOARD IS SHOWN WITH UNIVIEW™ DIGIT TECHNOLOGY. SEE DRAWING A-158550 FOR MORE DETAILS.

WEIGHTS	
SHIPPING WEIGHT	MOUNTING WEIGHT
152 LBS (70 KG)	92 LBS (43 KG)

TUFFSPORT™, COLORSMART™ & UNIVIEW™ ARE TRADEMARKS OF DAKTRONICS

THE CONCEPTS EXPRESSED AND DETAILS SHOWN ON THIS DRAWING ARE CONFIDENTIAL AND PROPRIETARY. DO NOT REPRODUCE BY ANY MEANS, INCLUDING ELECTRONICALLY WITHOUT THE EXPRESSED WRITTEN CONSENT OF DAKTRONICS, INC. COPYRIGHT 2006 DAKTRONICS, INC.

DAKTRONICS, INC. BROOKINGS, SD 57006

PROJ: TUFFSPORT™ COLORSMART™ SCOREBOARDS

TITLE: MECHANICAL SPEC- MCAST- BB-3121

DES. BY: JFELDHA

DRAWN BY: JFELDHA

DATE: 21 AUG 06

REV.	DATE	DESCRIPTION	BY	APPR.
00				

REVISION	APPR. BY:
00	
	SCALE: 1=40

1389-E10A-282963

SD-3101

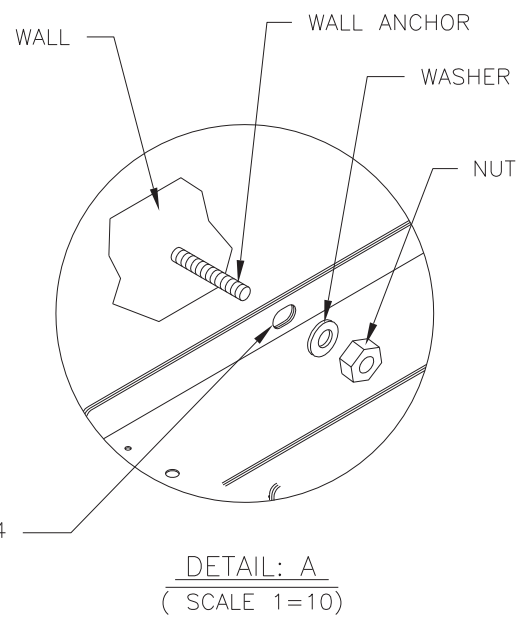
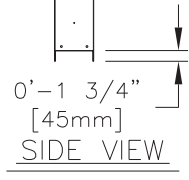
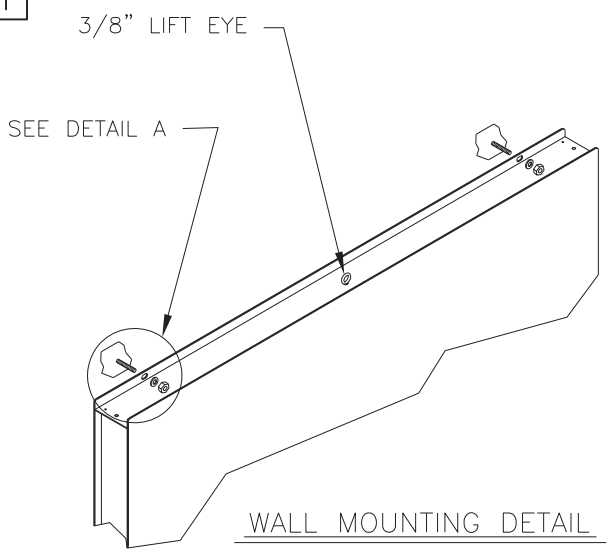
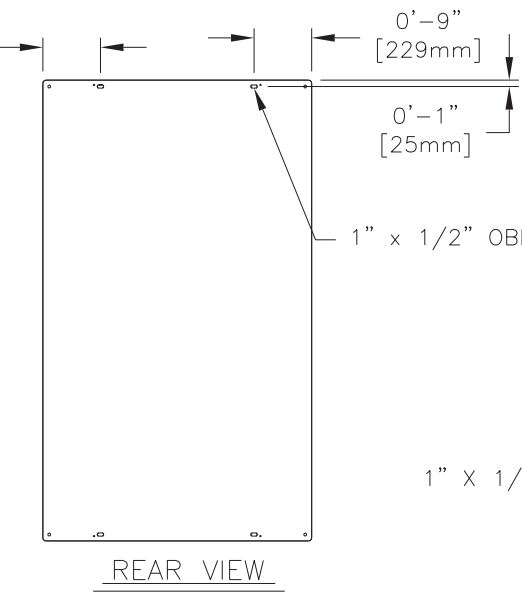
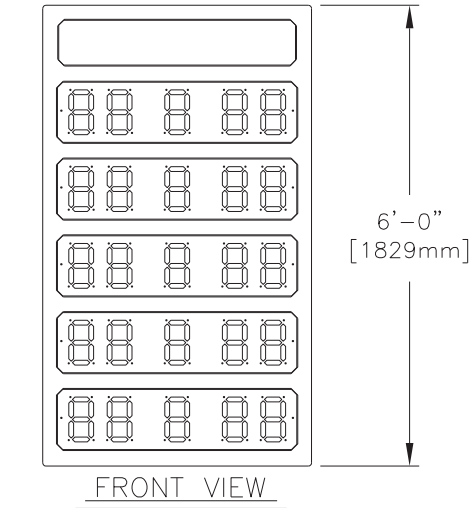
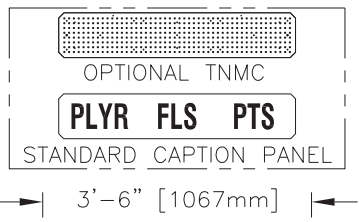

NOTES:

1. USE APPROPRIATE WALL ANCHORS FOR TYPE OF WALL.
2. LIFT EYE IS FOR TEMPORARY USE WHILE LIFTING SCOREBOARDS DURING INSTALLATION. DO NOT USE LIFT EYE FOR PERMANENT SUSPENSION.
3. SEE DRAWING 1237-R10A-148644 FOR OPTIONAL PERMANENT SUSPENSION OF THE SCOREBOARD.
4. THE SCOREBOARD IS SHOWN WITH UNIVIEW DIGIT TECHNOLOGY. SEE DRAWING A-158550 FOR MORE DETAILS.

WEIGHTS	
SHIPPING WEIGHT	MOUNTING WEIGHT
130 LBS (59 KG)	80 LBS (36 KG)

TUFFSPORT™ COLORSMART™ & UNIVIEW™ ARE TRADEMARKS OF DAKTRONICS

THE CONCEPTS EXPRESSED AND DETAILS SHOWN ON THIS DRAWING ARE CONFIDENTIAL AND PROPRIETARY. DO NOT REPRODUCE BY ANY MEANS, INCLUDING ELECTRONICALLY WITHOUT THE EXPRESSED WRITTEN CONSENT OF DAKTRONICS, INC. COPYRIGHT 2006 DAKTRONICS, INC.			
DAKTRONICS, INC. BROOKINGS, SD 57006			
PROJ: TUFFSPORT™ COLORSMART™ SCOREBOARDS			
TITLE: MECHANICAL SPEC- MCAST- SD-3101			
DES. BY: JFELDHA		DRAWN BY: JFELDHA	DATE: 21 AUG 06
REVISION	APPR. BY:	1389-E10A-282965	
00	SCALE: 1=30		

REV.	DATE	DESCRIPTION	BY	APPR.

SD-3102

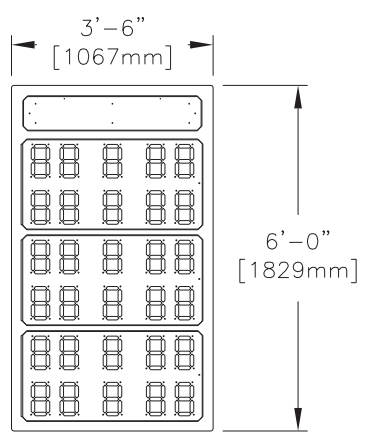
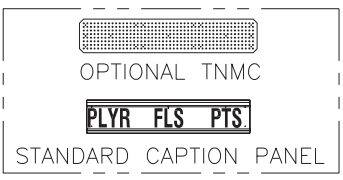
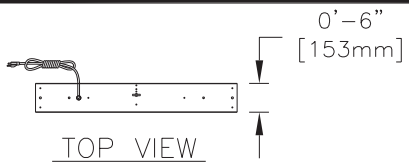

FRONT VIEW

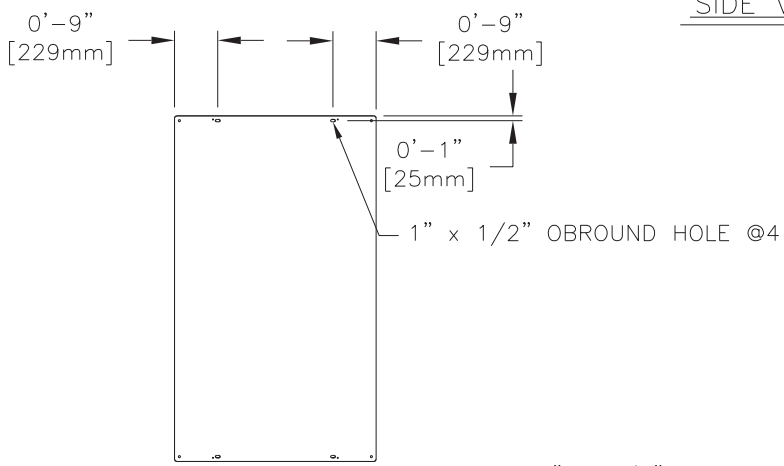

REAR VIEW

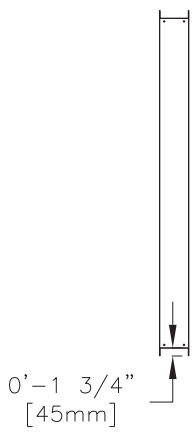

SIDE VIEW

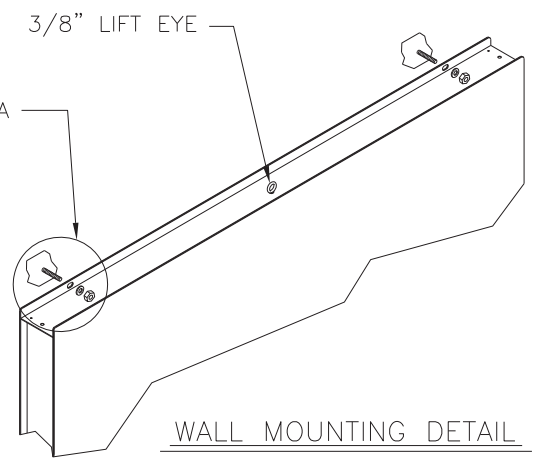

WALL MOUNTING DETAIL

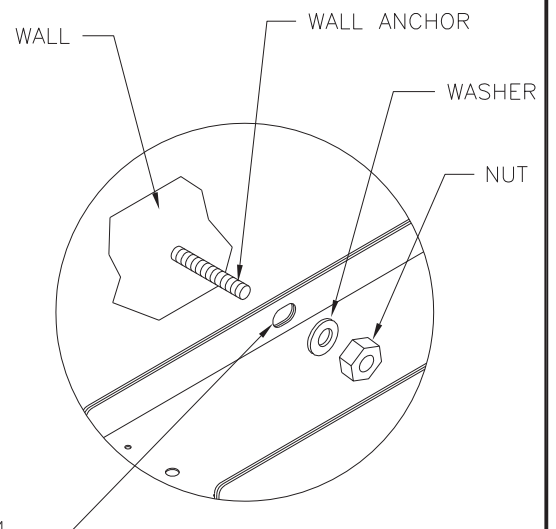

1" X 1/2" OBROUND HOLE @4

DETAIL: A
(SCALE 1=10)

NOTES:

1. USE APPROPRIATE WALL ANCHORS FOR TYPE OF WALL.
2. LIFT EYE IS FOR TEMPORARY USE WHILE LIFTING SCOREBOARDS DURING INSTALLATION. DO NOT USE LIFT EYE FOR PERMANENT SUSPENSION.
3. SEE DRAWING 1237-R10A-148644 FOR OPTIONAL PERMANENT SUSPENSION OF THE SCOREBOARD.
4. THE SCOREBOARD IS SHOWN WITH UNIVIEW DIGIT TECHNOLOGY. SEE DRAWING A-158550 FOR MORE DETAILS.

WEIGHTS	
SHIPPING WEIGHT	MOUNTING WEIGHT
155 LBS (70 KG)	90 LBS (41 KG)

TUFFSPORT™ COLORSMART™ & UNIVIEW™ ARE TRADEMARKS OF DAKTRONICS

THE CONCEPTS EXPRESSED AND DETAILS SHOWN ON THIS DRAWING ARE CONFIDENTIAL AND PROPRIETARY. DO NOT REPRODUCE BY ANY MEANS, INCLUDING ELECTRONICALLY WITHOUT THE EXPRESSED WRITTEN CONSENT OF DAKTRONICS, INC. COPYRIGHT 2006 DAKTRONICS, INC.

DAKTRONICS, INC. BROOKINGS, SD 57006

PROJ: TUFFSPORT™ COLORSMART™ SCOREBOARDS

TITLE: MECHANICAL SPEC- MCAST- SD-3102

DES. BY: JFELDHA DRAWN BY: JFELDHA DATE: 21 AUG 06

REVISION	APPR. BY:	1389-E10A-282967
00	SCALE: 1=40	

REV.	DATE	DESCRIPTION	BY	APPR.

SD-3103

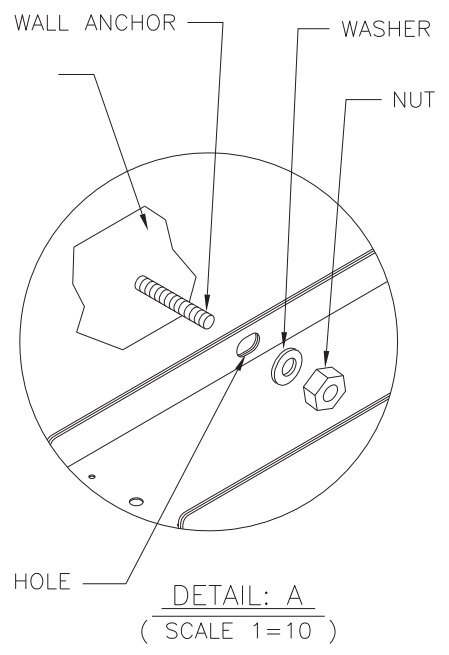
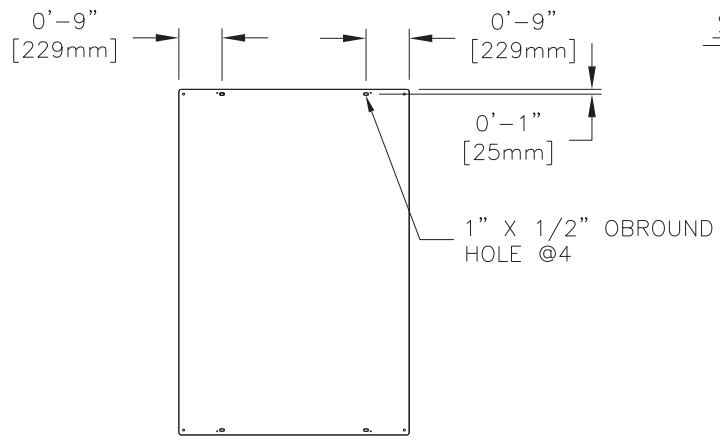
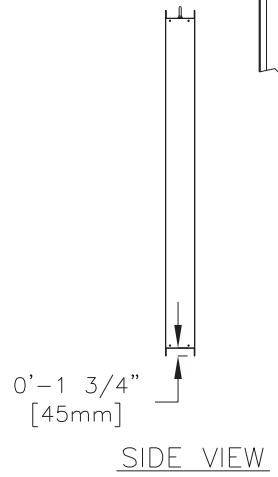
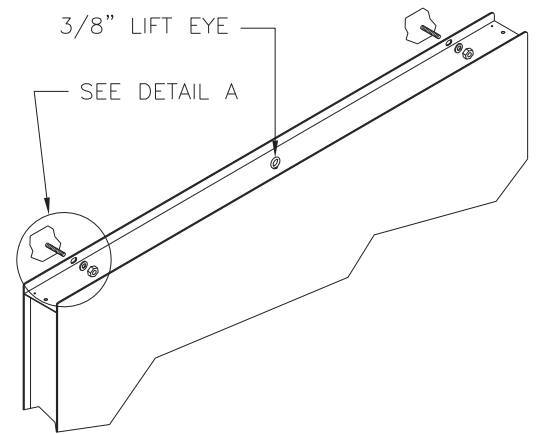
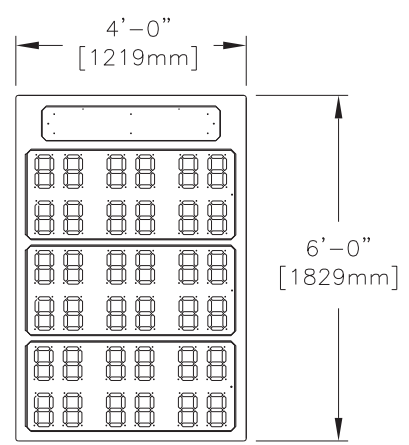
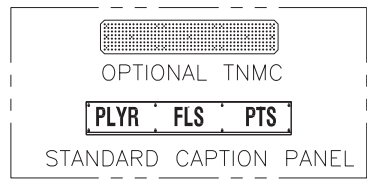
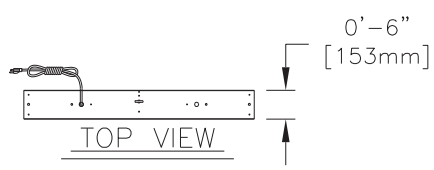

NOTES:

1. USE APPROPRIATE WALL ANCHORS FOR TYPE OF WALL.
2. LIFT EYE IS FOR TEMPORARY USE WHILE LIFTING SCOREBOARDS DURING INSTALLATION. DO NOT USE LIFT EYE FOR PERMANENT SUSPENSION.
3. SEE DRAWING 1237-R10A-148644 FOR OPTIONAL PERMANENT SUSPENSION OF THE SCOREBOARD.
4. THE SCOREBOARD IS SHOWN WITH UNIVIEW DIGIT TECHNOLOGY. SEE DRAWING A-158550 FOR MORE DETAILS.

WEIGHTS	
SHIPPING WEIGHT	MOUNTING WEIGHT
165 LBS (75 KG)	100 LBS (45 KG)

TUFFSPORT™ COLORSMART™ & UNIVIEW™ ARE TRADEMARKS OF DAKTRONICS

THE CONCEPTS EXPRESSED AND DETAILS SHOWN ON THIS DRAWING ARE CONFIDENTIAL AND PROPRIETARY. DO NOT REPRODUCE BY ANY MEANS, INCLUDING ELECTRONICALLY WITHOUT THE EXPRESSED WRITTEN CONSENT OF DAKTRONICS, INC. COPYRIGHT 2006 DAKTRONICS, INC.	
DAKTRONICS, INC. BROOKINGS, SD 57006	
PROJ: TUFFSPORT™ COLORSMART™ SCOREBOARDS	
TITLE: MECHANICAL SPEC- MCAST- SD-3103	
DES. BY: JFELDHA	DATE: 21 AUG 06
REVISION	APPR. BY:
00	SCALE: 1=40
1389-E10A-282969	

REV.	DATE	DESCRIPTION	BY	APPR.

BB-3142

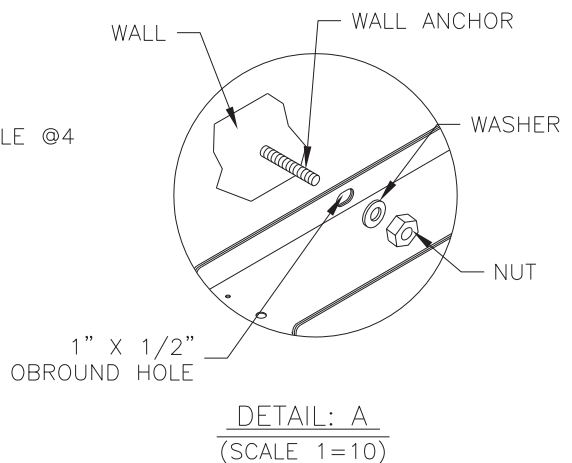
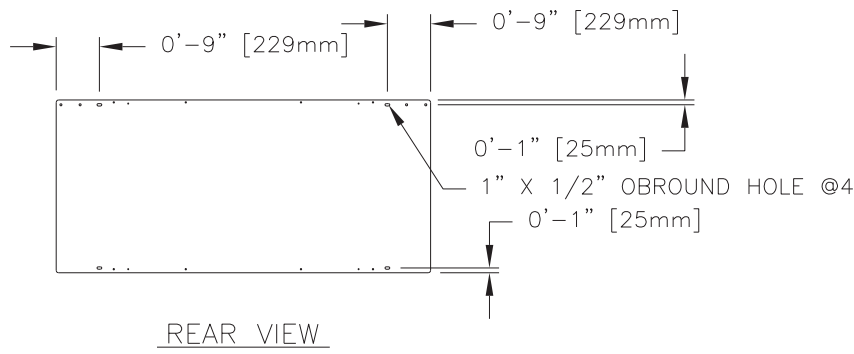
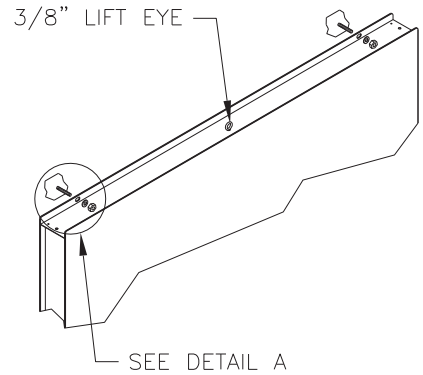
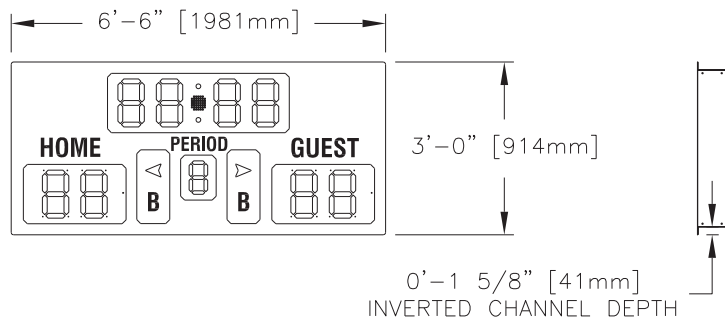
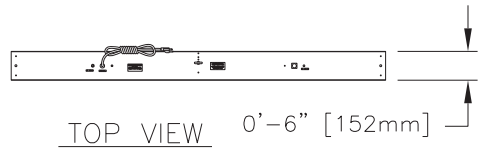

NOTES:

1. USE APPROPRIATE WALL ANCHORS FOR TYPE OF WALL.
2. LIFT EYE IS FOR TEMPORARY USE WHILE LIFTING SCOREBOARD DURING INSTALLATION. DO NOT USE LIFT EYE FOR PERMANENT SUSPENSION.
3. SEE DRAWING 1237-R10A-148644 FOR OPTIONAL PERMANENT SUSPENSION OF THE SCOREBOARD.
4. THE SCOREBOARD IS SHOWN WITH UNIVIEW™ DIGIT TECHNOLOGY. SEE DRAWING A-158550 FOR MORE DETAILS.

WEIGHTS	
SHIPPING WEIGHT	MOUNTING WEIGHT
120 LBS (55 KG)	80 LBS (36 KG)

TUFF SPORT™ & COLORSMART™ ARE TRADEMARKS OF DAKTRONICS

THE CONCEPTS EXPRESSED AND DETAILS SHOWN ON THIS DRAWING ARE CONFIDENTIAL AND PROPRIETARY. DO NOT REPRODUCE BY ANY MEANS, INCLUDING ELECTRONICALLY WITHOUT THE EXPRESSED WRITTEN CONSENT OF DAKTRONICS, INC. COPYRIGHT 2009 DAKTRONICS, INC.

DAKTRONICS, INC. BROOKINGS, SD 57006

PROJ: COLORSMART™ SCOREBOARDS

TITLE: MECHANICAL SPEC, MCAST-BB-3142

DES. BY: CBRECZI

DRAWN BY: LMIX

DATE: 05 JAN 10

REV.	DATE	DESCRIPTION	BY	APPR.
01	03 FEB 10	CHANGED TO 14-SEGMENT DIGITS	JLR	

REVISION 01

APPR. BY:

SCALE: 1=40

1389-E10A-956971

BB-3125

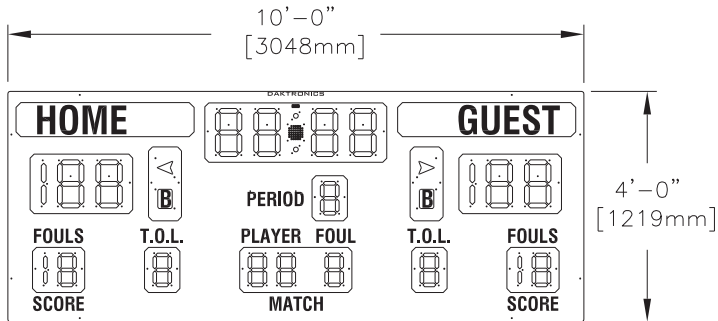
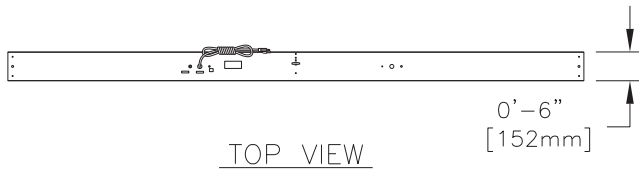

0'-1 5/8" [41mm]
INVERTED CHANNEL DEPTH

SIDE VIEW

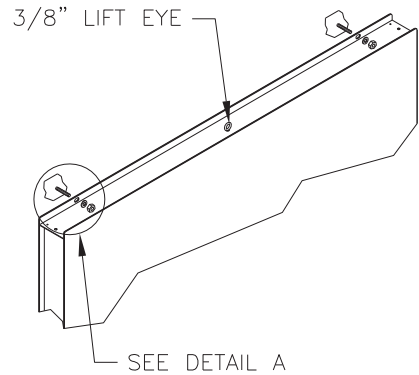

WALL MOUNTING DETAIL

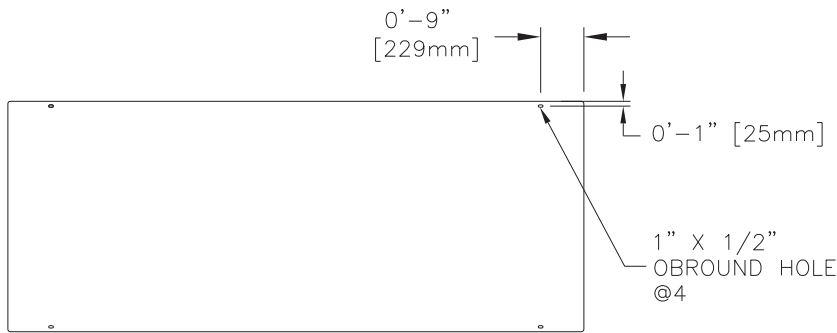

REAR VIEW

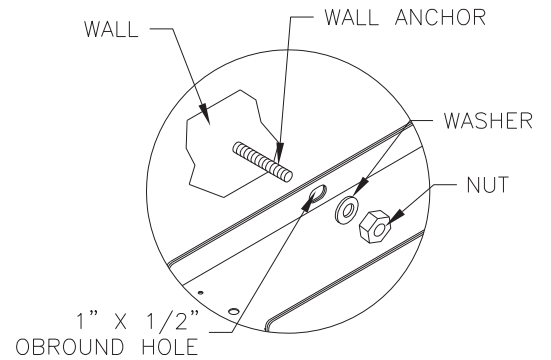

DETAIL: A
(SCALE 1=10)

NOTES:

1. USE APPROPRIATE WALL ANCHORS FOR TYPE OF WALL.
2. LIFT EYE IS FOR TEMPORARY USE WHILE LIFTING SCOREBOARD DURING INSTALLATION. DO NOT USE LIFT EYE FOR PERMANENT SUSPENSION.
3. SEE DRAWING 1237-R10A-148644 FOR OPTIONAL PERMANENT SUSPENSION OF THE SCOREBOARD.
4. THE SCOREBOARD IS SHOWN WITH UNIVIEW™ DIGIT TECHNOLOGY. SEE DRAWING A-158550 FOR MORE DETAILS.

WEIGHTS	
SHIPPING WEIGHT	MOUNTING WEIGHT
240 LBS (109 KG)	150 LBS (68 KG)

TUFF SPORT™, & COLORSMART™ ARE TRADEMARKS OF DAKTRONICS

THE CONCEPTS EXPRESSED AND DETAILS SHOWN ON THIS DRAWING ARE CONFIDENTIAL AND PROPRIETARY. DO NOT REPRODUCE BY ANY MEANS, INCLUDING ELECTRONICALLY WITHOUT THE EXPRESSED WRITTEN CONSENT OF DAKTRONICS, INC. COPYRIGHT 2009 DAKTRONICS, INC.

DAKTRONICS, INC. BROOKINGS, SD 57006

PROJ: COLORSMART™ SCOREBOARDS

TITLE: MECHANICAL SPEC, MCAST-BB-3125

DES. BY: BPETERSON

DRAWN BY: LMIX

DATE: 05 JAN 10

REVISION

APPR. BY:

00

SCALE: 1=40

1389-E10A-957066

REV.	DATE	DESCRIPTION	BY	APPR.

BB-3123

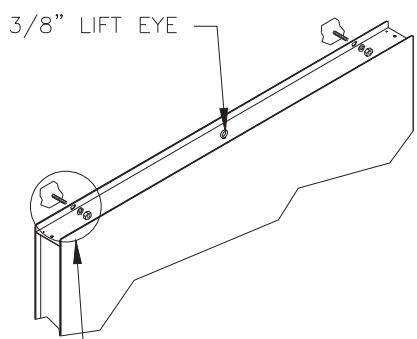
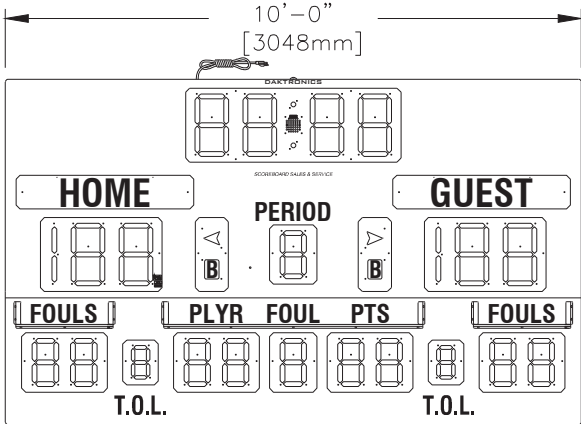
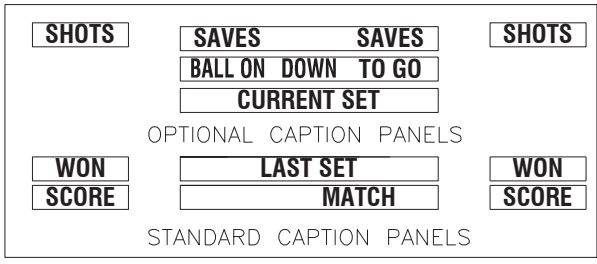
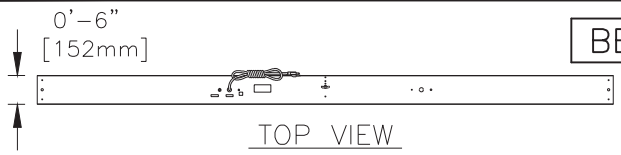

WALL MOUNTING DETAIL

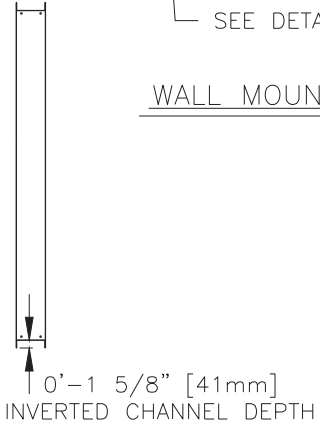

SIDE VIEW

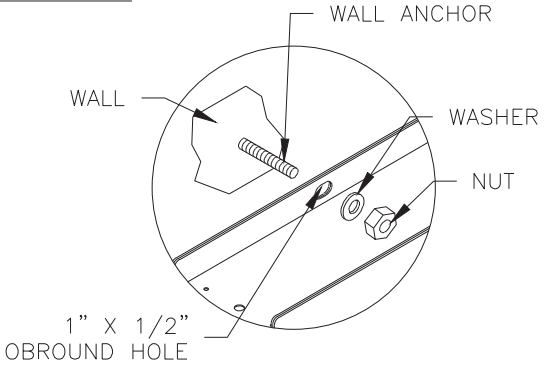
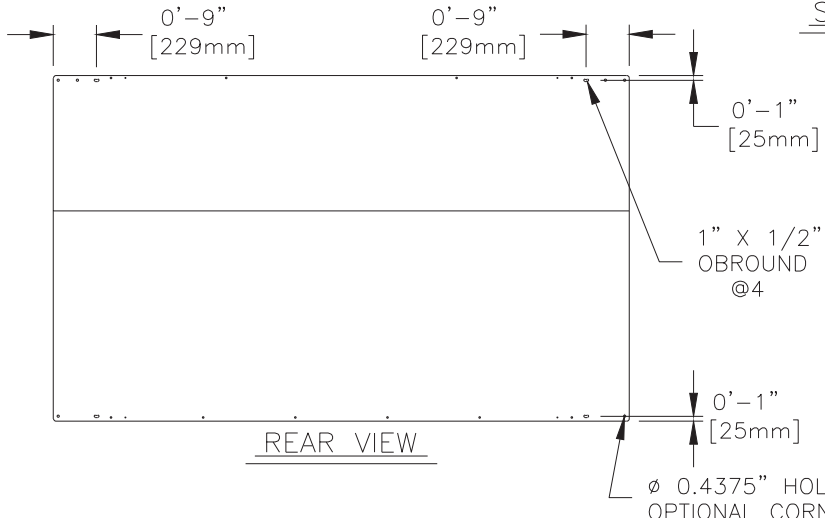

DETAIL: A (SCALE 1=10)

NOTES:

1. USE APPROPRIATE WALL ANCHORS FOR TYPE OF WALL.
2. LIFT EYE IS FOR TEMPORARY USE WHILE LIFTING SCOREBOARD DURING INSTALLATION. DO NOT USE LIFT EYE FOR PERMANENT SUSPENSION.
3. SEE DRAWING 1237-R10A-148644 FOR OPTIONAL PERMANENT SUSPENSION OF THE SCOREBOARD.
4. THE SCOREBOARD IS SHOWN WITH COLORSMART™ DIGIT TECHNOLOGY. SEE DRAWING A-158550 FOR MORE DETAILS.

WEIGHTS

SHIPPING WEIGHT	MOUNTING WEIGHT
370 LBS (168 KG)	230 LBS (104 KG)

TUFF SPORT™ & COLORSMART™ ARE TRADEMARKS OF DAKTRONICS

<p>DAKTRONICS, INC. BROOKINGS, SD 57006</p>	<p>THE CONCEPTS EXPRESSED AND DETAILS SHOWN ON THIS DRAWING ARE CONFIDENTIAL AND PROPRIETARY. DO NOT REPRODUCE BY ANY MEANS WITHOUT THE EXPRESSED WRITTEN CONSENT OF DAKTRONICS, INC. COPYRIGHT 2011 DAKTRONICS, INC.</p>		
	<p>DO NOT SCALE DRAWING</p>		
<p>PROJ: TUFF SPORT™ SCOREBOARDS</p>			
<p>TITLE: MECHANICAL SPEC; BB-3123</p>			
<p>DESIGN: DOPPELT</p>		<p>DRAWN: ZRYKHUS</p>	<p>DATE: 16 AUG 11</p>
<p>SCALE: 1=40</p>			
<p>SHEET</p>	<p>REV</p>	<p>JOB NO:</p>	<p>FUNC-TYPE-SIZE</p>
	<p>00</p>	<p>P1237</p>	<p>E-10-A</p>
			<p>1065737</p>

Appendix B: Electrical Specification Drawings

<i>Drawing Title</i>	<i>Drawing Number</i>
Electrical and Signal Spec- MCAST- BB-3101/BB-3102	A-282952
Electrical and Signal Spec-MCAST-BB-3103/BB-3104	A-282954
Electrical and Signal Spec-MCAST-BB-3105/BB-3106	A-282956
Electrical and Signal Spec-MCAST-BB-3107/BB-3108	A-282958
Electrical and Signal Spec- MCAST- BB-3114 (prior to Sept 2011)	A-282960
Electrical and Signal Spec- MCAST- BB-3115 (prior to Dec 2012)	A-282962
Electrical and Signal Spec- MCAST- BB-3121	A-282964
Electrical and Signal Spec- MCAST- SD-3101	A-282966
Electrical and Signal Spec- MCAST- SD-3102	A-282968
Electrical and Signal Spec- MCAST- SD-3103	A-282970
Electrical & Signal Spec, MCAST-BB-3142	A-956953
Electrical & Signal Spec, MCAST-BB-3125& BB-2126	A-956998
Electrical and Signal Spec; BB-3123/3124	A-1065749
Electrical and Signal Spec; MCAST, BB-3114	A-1066728
Electrical and Signal MCAST, BB-3115	A-1123280

BB-3101 & BB-3102 FACE

DIGIT, SIGNAL AND POWER SPECIFICATIONS:

NOTES:

1. USE MINIMUM OF 22AWG, SHIELDED, TWO CONDUCTOR CABLE FOR SIGNAL TERMINATION.
2. THE NUMBER LISTED BY EACH DIGIT INDICATES THE DIGIT DESIGNATION IN RELATION TO THE LED DRIVER.
3. **DO NOT WORK ON ENERGIZED DISPLAY UNLESS YOU ARE A CERTIFIED ELECTRICIAN OR DIRECTED BY DAKTRONICS.**
4. THE SCOREBOARD IS SHOWN WITH COLORSMART™ DIGIT TECHNOLOGY. SEE DRAWING A-158550 FOR MORE DETAILS.

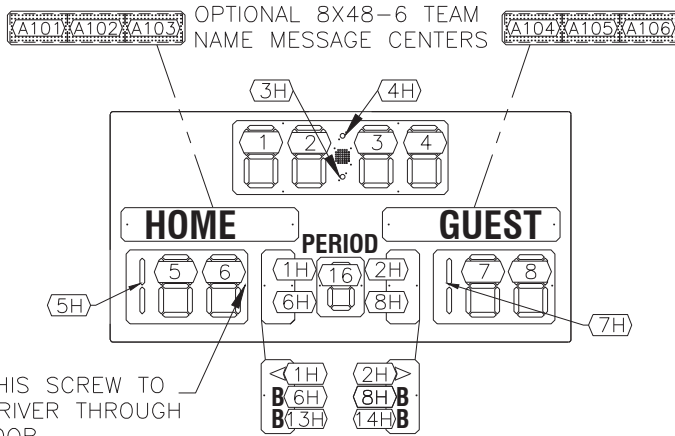

REMOVE THIS SCREW TO ACCESS DRIVER THROUGH HINGED DOOR.

OPTIONAL DOUBLE BONUS PANELS

FRONT VIEW

ADDRESS INFORMATION	
DRIVER:	A1
ADDRESS:	17
OPTIONAL TNMC, ADDRESS 221. ALSO SET HOME OR GUEST DIP SWITCH DEPENDING ON LOCATION	

COMPONENT LOCATIONS:

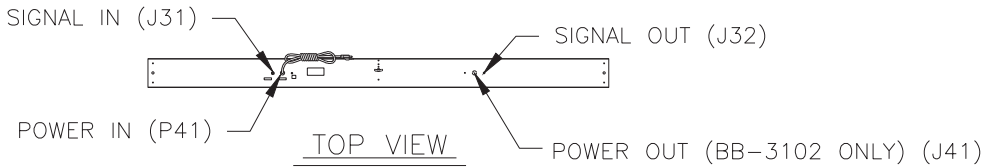

INTERNALLY MOUNTED BUZZER HORN (LS1)

SIGNAL TERMINATION BLOCK (TB31)

16 COLUMN LED DRIVER (A1)

TRANSFORMER (T1)

TRANSFORMER (T2)

HOLE FOR OPTIONAL RADIO CONTROL ANTENNA

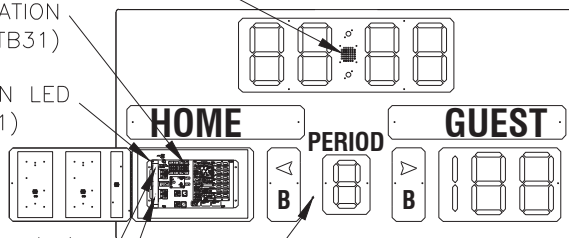

DIGITS:

- CLOCK: 13" AMBER/RED/GREEN
- SCORE: 13" RED/AMBER/GREEN
- PERIOD: 10" AMBER
- POSSESSION: 3" RED ARROW
- BONUS: 4" AMBER B & 3" ARROW

TUFF SPORT™ AND COLORSMART™ ARE TRADEMARKS OF DAKTRONICS

<p style="font-size: small; margin: 0;">BROOKINGS, SD 57006</p>	DO NOT SCALE DRAWING			THE CONCEPTS EXPRESSED AND DETAILS SHOWN ON THIS DRAWING ARE CONFIDENTIAL AND PROPRIETARY. DO NOT REPRODUCE BY ANY MEANS WITHOUT THE EXPRESSED WRITTEN CONSENT OF DAKTRONICS, INC. COPYRIGHT 2011 DAKTRONICS, INC.		
	PROJ.:COLORSMART™ MCAST SCOREBOARDS					
TITLE:ELECTRICAL AND SIGNAL SPEC- MCAST- BB-3101/BB-3102						
DESIGN:JFELDHA			DRAWN:JFELDHA		DATE: 21 AUG 06	
SCALE: 1=40						
SHEET	REV	JOB NO:	FUNC-TYPE-SIZE			
04	P1389	E-10-A	282952			

REV	DATE:	DESCRIPTION	BY:
04	08 APR 11	UPDATED DOUBLE BONUS OPTIONS	KDD
03	03 DEC 09	UPDATED DRIVER	JLR
02	21 AUG 09	ADDED TNMC ADDRESS INFO.	MWM
01	28 SEP 07	UPDATED NOTES AND ADDED BB-3102.	KJB

BB-3103 & BB-3104 FACE

DIGIT, SIGNAL AND POWER SPECIFICATIONS:

NOTES:

1. USE MINIMUM OF 22AWG, SHIELDED, TWO CONDUCTOR CABLE FOR SIGNAL TERMINATION.
2. THE NUMBER LISTED BY EACH DIGIT INDICATES THE DIGIT DESIGNATION IN RELATION TO THE LED DRIVER.
3. **DO NOT WORK ON ENERGIZED DISPLAY UNLESS YOU ARE A CERTIFIED ELECTRICIAN OR DIRECTED BY DAKTRONICS.**
4. THE SCOREBOARD IS SHOWN WITH COLORSMART™ DIGIT TECHNOLOGY. SEE DRAWING A-158550 FOR MORE DETAILS.

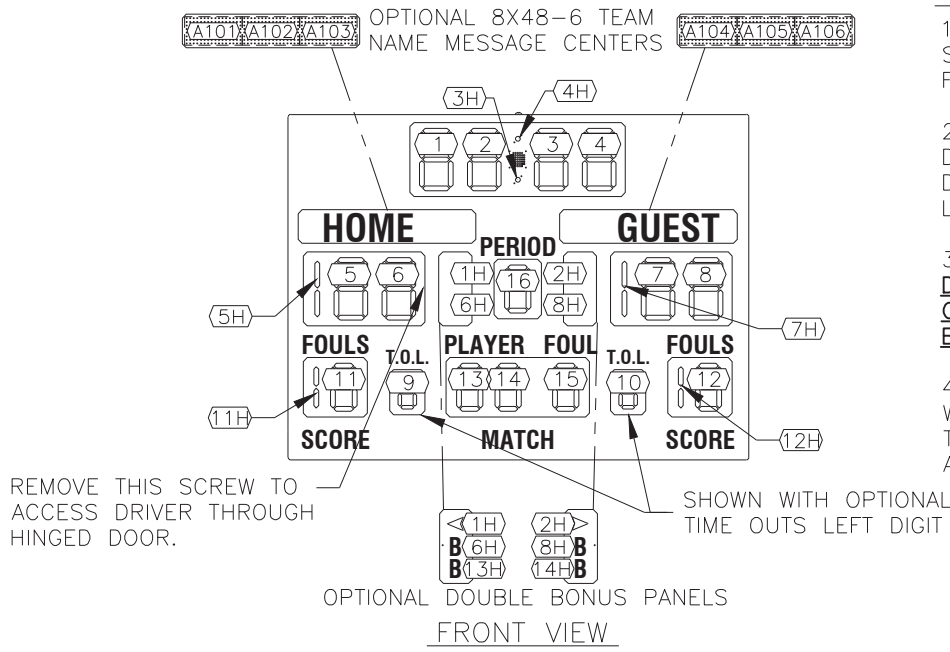

ADDRESS INFORMATION

DRIVER:	A1
ADDRESS:	17
OPTIONAL TNMC, ADDRESS 221. ALSO SET HOME OR GUEST DIP SWITCH DEPENDING ON LOCATION	

COMPONENT LOCATIONS:

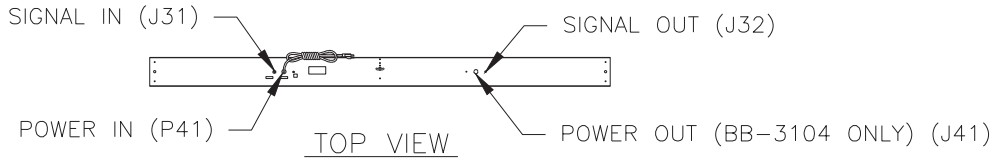

DIGITS:

- CLOCK: 13" AMBER/RED/GREEN
- SCORE: 13" RED/AMBER/GREEN
- PERIOD: 10" AMBER
- TEAM FOULS: 10" RED
- TIME OUTS LEFT: 7" AMBER
- PLAYER/FOUL: 10" AMBER
- POSSESSION: 3" RED ARROW
- BONUS: 4" AMBER B & 3" ARROW

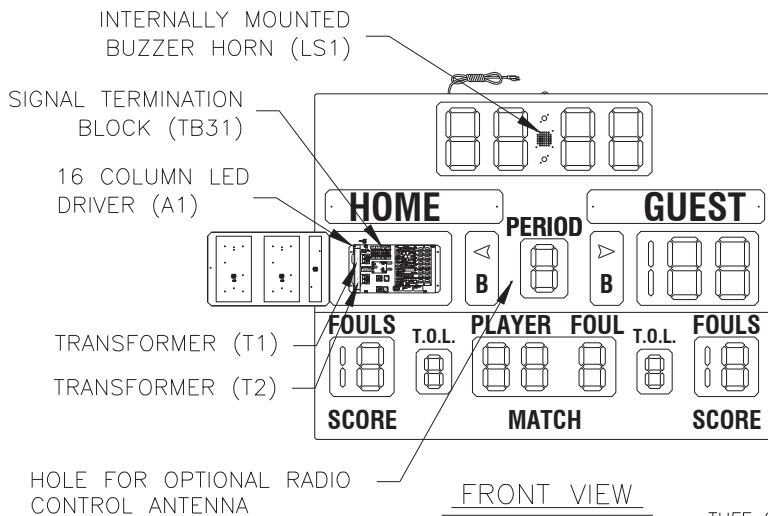

TUFF SPORT™ & COLORSMART™ ARE TRADEMARKS OF DAKTRONICS

DAKTRONICS, INC. BROOKINGS, SD 57006	THE CONCEPTS EXPRESSED AND DETAILS SHOWN ON THIS DRAWING ARE CONFIDENTIAL AND PROPRIETARY. DO NOT REPRODUCE BY ANY MEANS WITHOUT THE EXPRESSED WRITTEN CONSENT OF DAKTRONICS, INC. COPYRIGHT 2011 DAKTRONICS, INC.		
	DO NOT SCALE DRAWING		
PROJ: COLORSMART™ MCAST SCOREBOARDS			
TITLE: ELECTRICAL AND SIGNAL SPEC-MCAST-BB-3103/BB-3104			
DESIGN: JFELDHA		DRAWN: JFELDHA	DATE: 21 AUG 06 X
SCALE: 1 = 40			
SHEET	REV	JOB NO:	FUNC-TYPE-SIZE
	04	P1389	E-10-A
			282954

REV 04	DATE: 08 APR 11	UPDATED DOUBLE BONUS OPTION	BY: KDD
REV 03	DATE: 03 DEC 09	UPDATED DRIVER	BY: JLR
REV 02	DATE: 21 AUG 09	ADDED TNMC ADDRESS INFO.	BY: MWM
REV 01	DATE: 28 SEP 07	UPDATED NOTES AND ADDED BB-3104.	BY: KJB

BB-3105 & BB-3106 FACE

DIGIT, SIGNAL AND POWER SPECIFICATIONS:

NOTES:

1. USE MINIMUM OF 22AWG, SHIELDED, TWO CONDUCTOR CABLE FOR SIGNAL TERMINATION.
2. THE NUMBER LISTED BY EACH DIGIT INDICATES THE DIGIT DESIGNATION IN RELATION TO THE LED DRIVER.
3. DO NOT WORK ON ENERGIZED DISPLAY UNLESS YOU ARE A CERTIFIED ELECTRICIAN OR DIRECTED BY DAKTRONICS.
4. THE SCOREBOARD IS SHOWN WITH COLORSMART™ DIGIT TECHNOLOGY. SEE DRAWING A-158550 FOR MORE DETAILS.

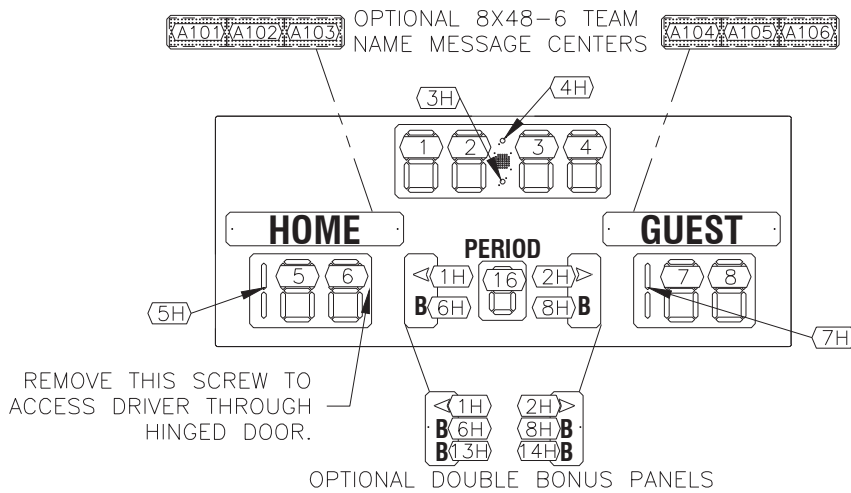

FRONT VIEW

ADDRESS INFORMATION	
DRIVER:	A1
ADDRESS:	17
OPTIONAL TNMC, ADDRESS 221. ALSO SET HOME OR GUEST DIP SWITCH DEPENDING ON LOCATION	

COMPONENT LOCATIONS:

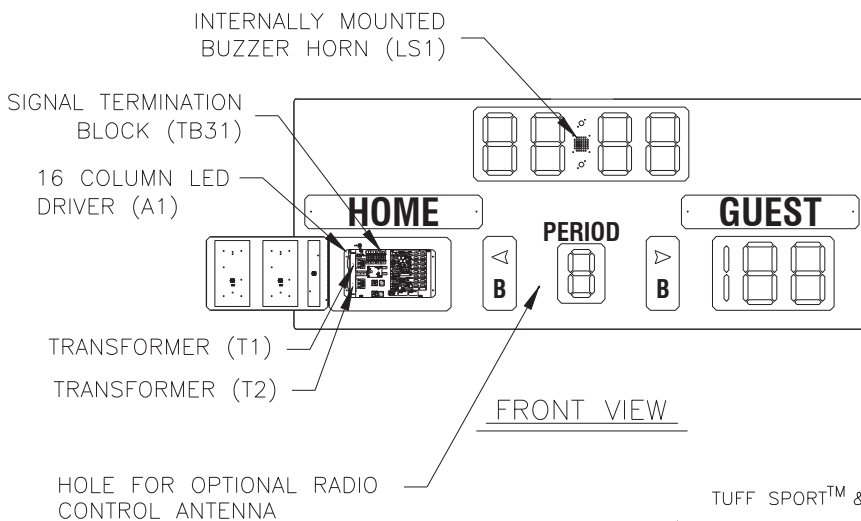
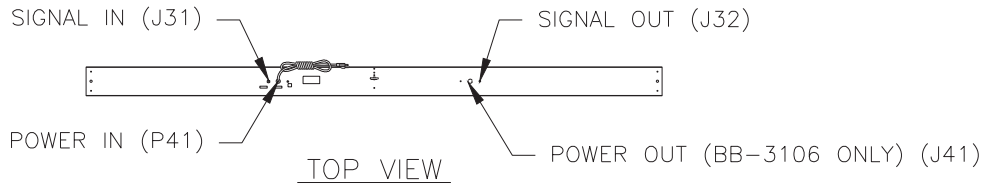

DIGITS:

- CLOCK: 13" AMBER/RED/GREEN
- SCORE: 13" RED/AMBER/GREEN
- PERIOD: 10" AMBER
- POSSESSION: 3" RED ARROW
- BONUS: 4" AMBER B & 3" ARROW

TUFF SPORT™ & COLORSMART™ ARE TRADEMARKS OF DAKTRONICS

DAKTRONICS, INC. BROOKINGS, SD 57006	THE CONCEPTS EXPRESSED AND DETAILS SHOWN ON THIS DRAWING ARE CONFIDENTIAL AND PROPRIETARY. DO NOT REPRODUCE BY ANY MEANS WITHOUT THE EXPRESSED WRITTEN CONSENT OF DAKTRONICS, INC. COPYRIGHT 2011 DAKTRONICS, INC.		
	DO NOT SCALE DRAWING		
PROJ.: COLORSMART™ MCAST SCOREBOARDS TITLE: ELECTRICAL AND SIGNAL SPEC-MCAST-BB-3105/BB-3106			
DESIGN: JFELDHA		DRAWN: JFELDHA	
SCALE: 1=40		DATE: 21 AUG 06	
SHEET	REV	JOB NO:	FUNC-TYPE-SIZE
	04	P1389	E-10-A
			282956

REV	DATE	DESCRIPTION	BY
04	08 APR 11	UPDATED DOUBLE BONUS OPTIONS	KDD
03	03 DEC 09	UPDATED DRIVER	JLR
02	21 AUG 09	ADDED TNMC ADDRESS INFO.	MWM
01	28 SEP 07	UPDATED NOTES AND ADDED BB-3106.	KJB

BB-3107 & BB-3108 FACE

DIGIT, SIGNAL AND POWER SPECIFICATIONS:

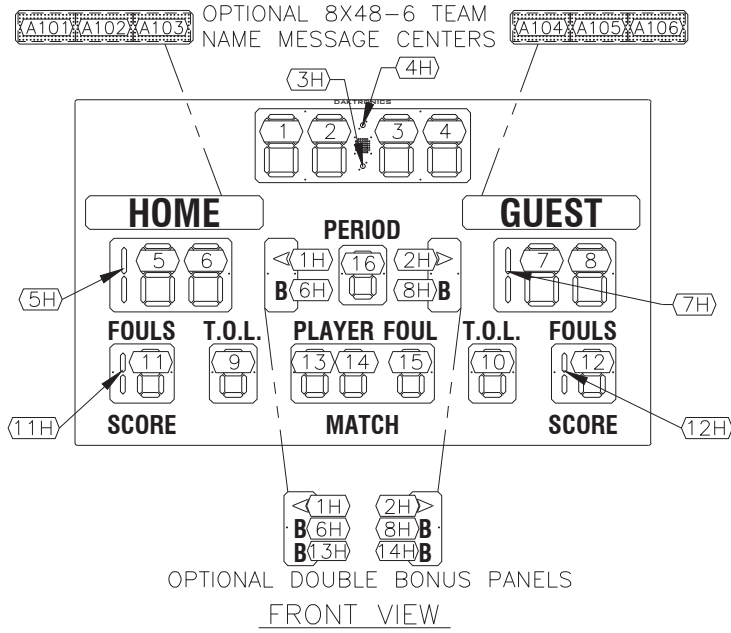

NOTES:

1. USE MINIMUM OF 22AWG, SHIELDED, TWO CONDUCTOR CABLE FOR SIGNAL TERMINATION.
2. THE NUMBER LISTED BY EACH DIGIT INDICATES THE DIGIT DESIGNATION IN RELATION TO THE LED DRIVER.
3. **DO NOT WORK ON ENERGIZED DISPLAY UNLESS YOU ARE A CERTIFIED ELECTRICIAN OR DIRECTED BY DAKTRONICS.**
4. THE SCOREBOARD IS SHOWN WITH COLORSMART™ DIGIT TECHNOLOGY. SEE DRAWING A-158550 FOR MORE DETAILS.

ADDRESS INFORMATION	
DRIVER:	A1
ADDRESS:	17

COMPONENT LOCATIONS:

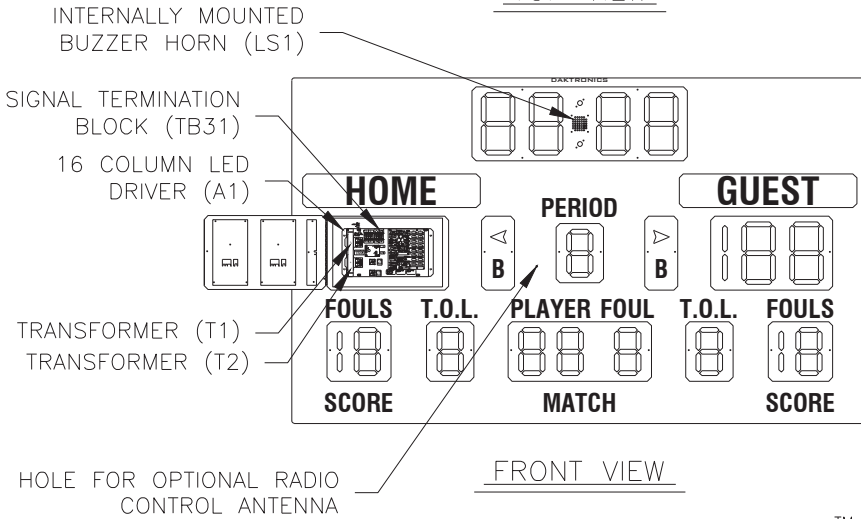
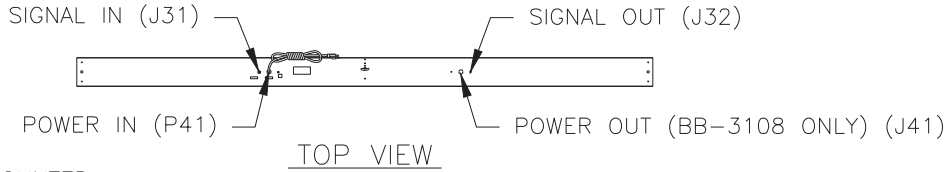

DIGITS:

- CLOCK: 13" AMBER/RED/GREEN
- SCORE: 13" RED/AMBER/GREEN
- PERIOD: 10" AMBER
- TEAM FOULS: 10" RED
- TIME OUTS LEFT: 7" AMBER
- PLAYER/FOUL: 10" AMBER
- POSSESSION: 3" RED ARROW
- BONUS: 4" AMBER B & 3" ARROW

TUFF SPORT™ & COLORSMART™ ARE TRADEMARKS OF DAKTRONICS

	DAKTRONICS, INC. BROOKINGS, SD 57006		THE CONCEPTS EXPRESSED AND DETAILS SHOWN ON THIS DRAWING ARE CONFIDENTIAL AND PROPRIETARY. DO NOT REPRODUCE BY ANY MEANS WITHOUT THE EXPRESSED WRITTEN CONSENT OF DAKTRONICS, INC. COPYRIGHT 2011 DAKTRONICS, INC.	
	DO NOT SCALE DRAWING			
PROJ:COLORSMART™ MCAST SCOREBOARDS TITLE:ELECTRICAL AND SIGNAL SPEC-MCAST-BB-3107/BB-3108				
DESIGN:JFELDHA		DRAWN:JFELDHA		DATE: 21 AUG 06
SCALE: 1 = 40				
SHEET	REV	JOB NO:	FUNC-TYPE-SIZE	282958
	03	P1389	E-10-A	

REV 03	DATE: 08 APR 11	UPDATED DOUBLE BONUS OPTIONS	BY: KDD
REV 02	DATE: 03 DEC 09	UPDATED DRIVER	BY: JLR
REV 01	DATE: 28 SEP 07	UPDATED NOTES AND ADDED BB-3108.	BY: KJB

BB-3114

DIGIT, SIGNAL AND POWER SPECIFICATIONS:

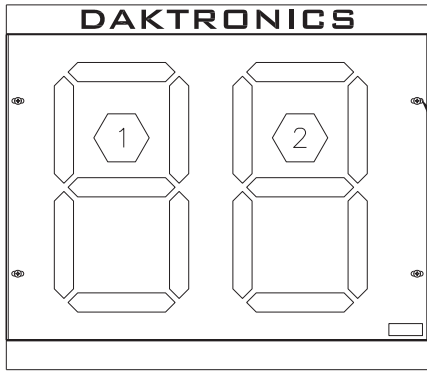

FRONT VIEW

TO GAIN ACCESS TO THE INTERIOR COMPONENTS, REMOVE THE FOUR SCREWS SECURING THE FACE PANEL.

NOTES:

1. USE MINIMUM OF 22AWG, SHIELDED, TWO CONDUCTOR CABLE FOR SIGNAL TERMINATION.
2. THE NUMBER LISTED BY EACH DIGIT INDICATES THE DIGIT DESIGNATION IN RELATION TO THE LED DRIVER.
3. **DO NOT WORK ON ENERGIZED DISPLAY UNLESS YOU ARE A CERTIFIED ELECTRICIAN OR DIRECTED BY DAKTRONICS.**
4. THE SCOREBOARD IS SHOWN WITH UNIVIEW DIGIT TECHNOLOGY. SEE DRAWING A-158550 FOR MORE DETAILS.

ADDRESS INFORMATION	
DRIVER:	A1
ADDRESS:	XX

COMPONENT LOCATIONS:

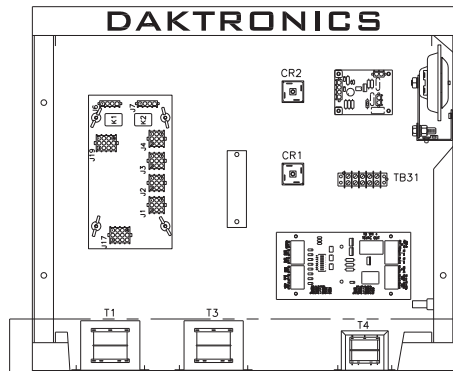

FRONT VIEW
WITH FACE PANEL REMOVED

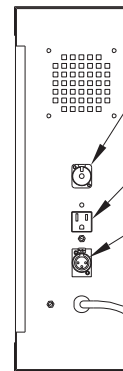

- J31
SIGNAL OUT
- J42
120V AC OUT
- J32
LIGHT STRIP
SAME AS J42

SIDE VIEW

NOTES:

1. LS1 IS CONNECTED TO THE SHOT CLOCK HORN SEGMENT.
2. J41 IS CONNECTED TO THE GAME CLOCK=0 SEGMENT.
3. TO ENABLE OTHER SEGMENTS, OR TO MAKE OTHER CHANGES, RECONNECT AT TB1.

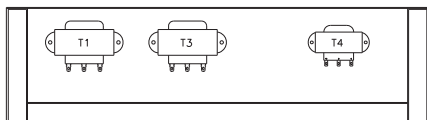

SECTION: A-A

TUFF SPORT™ & COLORSMART™ ARE TRADEMARKS OF DAKTRONICS

THE CONCEPTS EXPRESSED AND DETAILS SHOWN ON THIS DRAWING ARE CONFIDENTIAL AND PROPRIETARY. DO NOT REPRODUCE BY ANY MEANS, INCLUDING ELECTRONICALLY WITHOUT THE EXPRESSED WRITTEN CONSENT OF DAKTRONICS, INC. COPYRIGHT 2006 DAKTRONICS, INC.

DAKTRONICS, INC. BROOKINGS, SD 57006

PROJ: TUFF SPORT™ COLORSMART™ SCOREBOARDS

TITLE: ELECTRICAL AND SIGNAL SPEC- MCAST- BB-3114

DES. BY: JFELDHA

DRAWN BY: JFELDHA

DATE: 21 AUG 06

REVISION
00

APPR. BY:
SCALE: 1=10

1389-E10A-282960

REV.	DATE	DESCRIPTION	BY	APPR.

BB-3115

NOTES:

DIGIT, SIGNAL AND POWER SPECIFICATIONS:

TO GAIN ACCESS TO THE INTERIOR COMPONENTS, REMOVE THE SCREWS SECURING THE FACE PANEL. DOOR SWINGS DOWN ON HINGE.

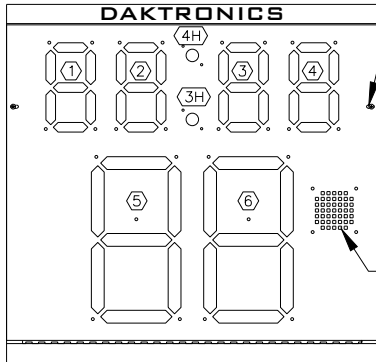

DS1 (HORN) DEFAULT SETTING:
GAME HORN & SHOT HORN

FRONT VIEW

1. USE MINIMUM OF 22AWG, SHIELDED, TWO CONDUCTOR CABLE FOR SIGNAL TERMINATION.

2. THE NUMBER LISTED BY EACH DIGIT INDICATES THE DIGIT DESIGNATION IN RELATION TO THE LED DRIVER.

3. **DO NOT WORK ON ENERGIZED DISPLAY UNLESS YOU ARE A CERTIFIED ELECTRICIAN OR DIRECTED BY DAKTRONICS.**

4. THE SCOREBOARD IS SHOWN WITH UNIVIEW DIGIT TECHNOLOGY. SEE DRAWING A-158550 FOR MORE DETAILS.

ADDRESS INFORMATION

DRIVER:	A1
ADDRESS:	01

COMPONENT LOCATIONS:

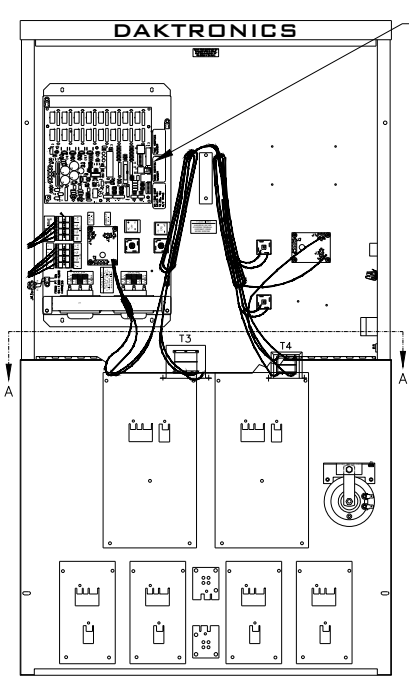

A1
LED DRIVER

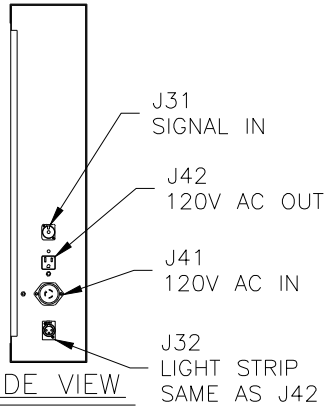

SIDE VIEW

NOTES:

1. DS1 IS CONNECTED TO J27 ON THE A1 DRVR FOR SHOT HORN. TO CHANGE FUNCTION TO GAME HORN RECONNECT HARNESS TO J26.
2. LIGHT STRIP OPTION IS CONNECTED TO J29 ON A1 DRVR.
3. VH1 LED CLUSTER ON ALL FACE PANELS IS CONNECTED TO J28 ON A1 DRVR.
4. SEE DRAWING A-159072 FOR PRIOR COMPONENT LOCATIONS.

FRONT VIEW

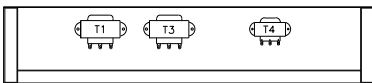

SECTION: A-A

TUFF SPORT™ & COLORSMART™ ARE TRADEMARKS OF DAKTRONICS

DAKTRONICS, INC. BROOKINGS, SD 57006 DO NOT SCALE DRAWING	THE CONCEPTS EXPRESSED AND DETAILS SHOWN ON THIS DRAWING ARE CONFIDENTIAL AND PROPRIETARY. DO NOT REPRODUCE BY ANY MEANS WITHOUT THE EXPRESSED WRITTEN CONSENT OF DAKTRONICS, INC. COPYRIGHT 2013 DAKTRONICS, INC.	
	PROJ: TUFF SPORT COLORSMART SCOREBOARDS TITLE: ELECTRICAL AND SIGNAL SPEC- MCAST- BB-3115	
DESIGN: JFELDHA SCALE: 1=15	DRAWN: JFELDHA	DATE: 21 AUG 06
SHEET 02	REV P 1389	JOB NO: E - 10 - A
		282962

REV 02	DATE: 8 JAN 13	UPDATED NOTES	BY: MBJ
01	03 DEC 09	UPDATED DRIVER AND COMPONENTS	JLR

BB-3121

DIGIT, SIGNAL AND POWER SPECIFICATIONS:

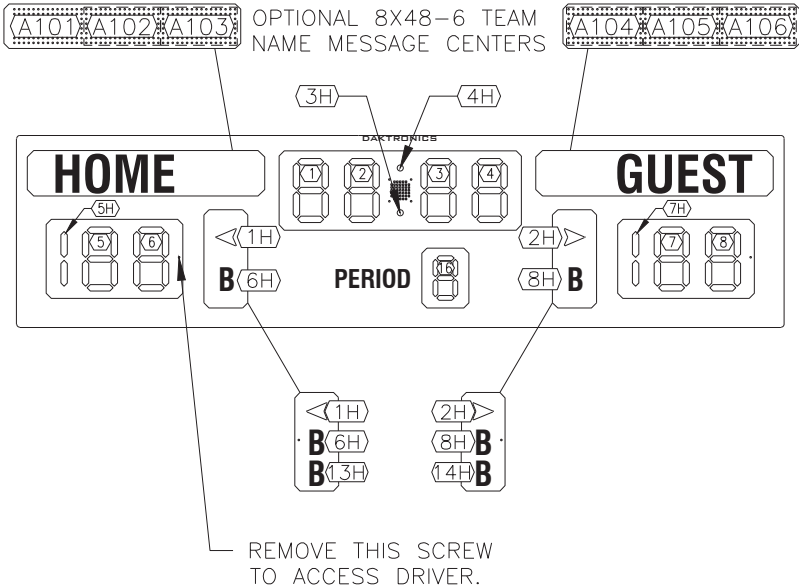

NOTES:

1. USE MINIMUM OF 22AWG, SHIELDED, TWO CONDUCTOR CABLE FOR SIGNAL TERMINATION.
2. THE NUMBER LISTED BY EACH DIGIT INDICATES THE LED DRIVER AND DIGIT DESIGNATION IN RELATION TO THE LED DRIVER.
3. **DO NOT WORK ON ENERGIZED DISPLAY UNLESS YOU ARE A CERTIFIED ELECTRICIAN OR DIRECTED BY DAKTRONICS.**
4. THE SCOREBOARD IS SHOWN WITH UNIVIEW DIGIT TECHNOLOGY. SEE DRAWING A-158550 FOR MORE DETAILS.

ADDRESS INFORMATION	
DRIVER:	A1
ADDRESS:	17

COMPONENT LOCATION:

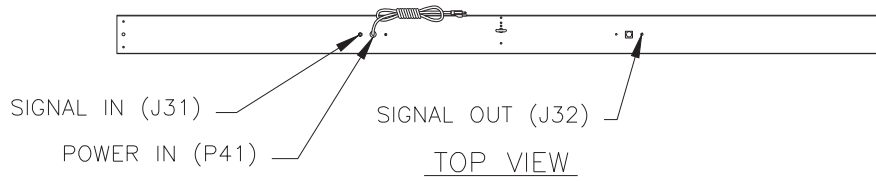

DIGITS:

- CLOCK: 10" AMBER
- SCORE: 10" RED
- PERIOD: 7" AMBER
- POSSESSION: 3" RED ARROW
- BONUS: 4" AMBER B & 3" ARROW

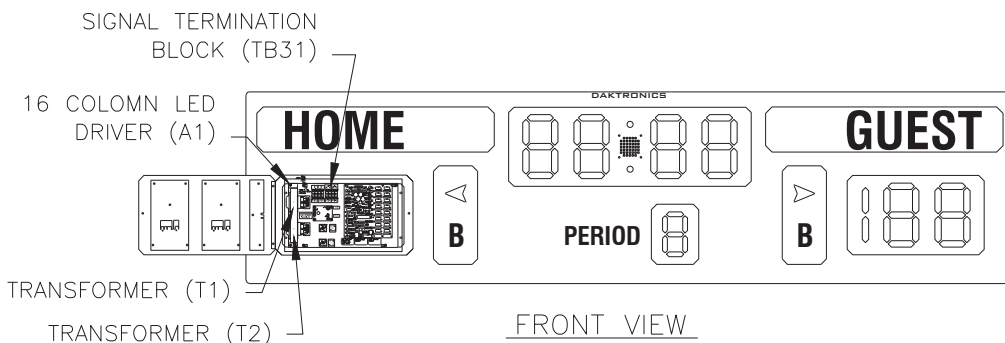

TUFF SPORT™ & COLORSMART™ ARE TRADEMARKS OF DAKTRONICS

	DAKTRONICS, INC. BROOKINGS, SD 57006		THE CONCEPTS EXPRESSED AND DETAILS SHOWN ON THIS DRAWING ARE CONFIDENTIAL AND PROPRIETARY. DO NOT REPRODUCE BY ANY MEANS WITHOUT THE EXPRESSED WRITTEN CONSENT OF DAKTRONICS, INC. COPYRIGHT 2011 DAKTRONICS, INC.	
	DO NOT SCALE DRAWING			
PROJ: TUFF SPORT™ COLORSMART™ SCOREBOARDS				
TITLE: ELECTRICAL AND SIGNAL SPEC- MCAST- BB-3121				
DESIGN: JFELDHA		DRAWN: JFELDHA		DATE: 21 AUG 06
SCALE: 1 = 30				
SHEET	REV	JOB NO:	FUNC-TYPE-SIZE	282964
02	P1389	E-10-A	02	

REV 02	DATE: 08 APR 11	UPDATED DOUBLE BONUS OPTIONS	BY: KDD
REV 01	DATE: 03 DEC 09	UPDATED DRIVER	BY: JLR

SD-3101

NOTES:

DIGIT, SIGNAL AND POWER SPECIFICATIONS:

OPTIONAL 8 X 48
ELECTRONIC CAPTION

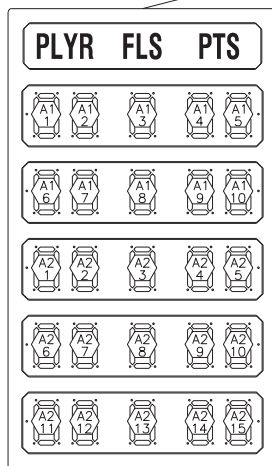
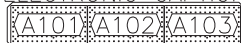

FRONT VIEW

1. USE MINIMUM OF 22AWG, SHIELDED, TWO CONDUCTOR CABLE FOR SIGNAL TERMINATION.

2. THE NUMBER LISTED BY EACH DIGIT INDICATES THE DIGIT DESIGNATION IN RELATION TO THE LED DRIVER.

3. **DO NOT WORK ON ENERGIZED DISPLAY UNLESS YOU ARE A CERTIFIED ELECTRICIAN OR DIRECTED BY DAKTRONICS.**

4. THE SCOREBOARD IS SHOWN WITH UNIVIEW DIGIT TECHNOLOGY. SEE DRAWING A-158550 FOR MORE DETAILS.

ADDRESS INFORMATION			
LEFT STATS SECTION		RIGHT STATS SECTION	
DRIVER:	A1	DRIVER:	A1
ADDRESS:	23	ADDRESS:	25
DRIVER:	A2	DRIVER:	A2
ADDRESS:	24	ADDRESS:	26

OPTIONAL ELECTRONIC CAPTION, ADDRESS 223 AND HOME/GUEST ADDRESS SWITCH SET TO GUEST (ON).

COMPONENT LOCATIONS:

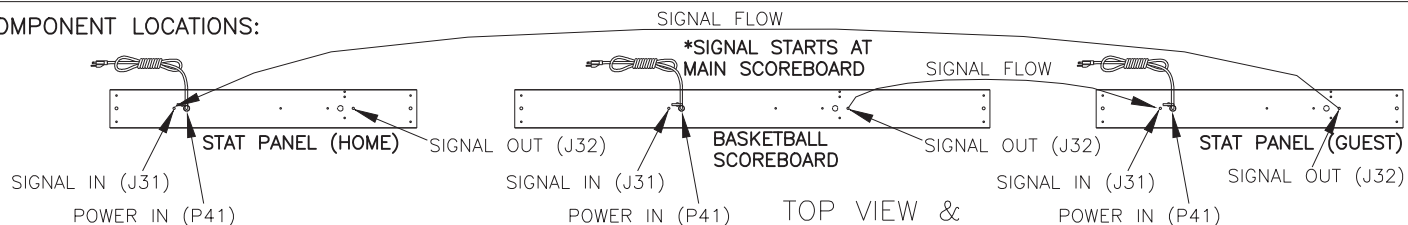

TOP VIEW & SIGNAL FLOW

*SIGNAL INSTRUCTIONS:

- SIGNAL FROM SOURCE LANDS TO MAIN BASKETBALL SCOREBOARD FIRST.
- THEN OUT FROM SCOREBOARD TO IN ON STATS PANEL.
- AND OUT FROM STATS PANEL TO IN ON OTHER STATS PANEL.

DIGITS

PLYR: 7" AMBER
FLS: 7" RED
PTS: 7" RED

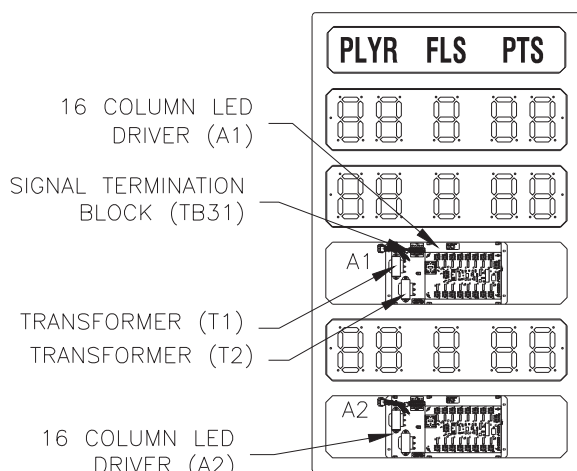

FRONT VIEW

TUFF SPORT™ & COLORSMART™ ARE TRADEMARKS OF DAKTRONICS

	DAKTRONICS, INC. BROOKINGS, SD 57006	THE CONCEPTS EXPRESSED AND DETAILS SHOWN ON THIS DRAWING ARE CONFIDENTIAL AND PROPRIETARY. DO NOT REPRODUCE BY ANY MEANS WITHOUT THE EXPRESSED WRITTEN CONSENT OF DAKTRONICS, INC. COPYRIGHT 2012 DAKTRONICS, INC.
	DO NOT SCALE DRAWING	
PROJ: TUFF SPORT COLORSMART SCOREBOARDS		
TITLE: ELECTRICAL AND SIGNAL SPEC- MCAST- SD-3101		
DESIGN: JFELDHA	DRAWN: JFELDHA	DATE: 21 AUG 06
SCALE: 1=30		
SHEET	REV	JOB NO:
02	1389	E - 10 - A
		282966

REV 02	DATE: 02 MAR 12	ADDED SCBD AND SIGNAL ROUTING.	BY: SMB	
REV 01	DATE: 21 AUG 09	CORRECT TITLE OF OPTIONAL "TNMC" TO ELECTRONIC CAPTION. ADDED ADDRESS TO CHART.	BY: MWM	

DIGIT, SIGNAL AND POWER SPECIFICATIONS:

SD-3102

NOTES:

1. USE MINIMUM OF 22AWG, SHIELDED, TWO CONDUCTOR CABLE FOR SIGNAL TERMINATION.
2. THE NUMBER LISTED BY EACH DIGIT INDICATES THE DIGIT DESIGNATION IN RELATION TO THE LED DRIVER.
3. **DO NOT WORK ON ENERGIZED DISPLAY UNLESS YOU ARE A CERTIFIED ELECTRICIAN OR DIRECTED BY DAKTRONICS.**
4. THE SCOREBOARD IS SHOWN WITH UNIVIEW DIGIT TECHNOLOGY. SEE DRAWING A-158550 FOR MORE DETAILS.

OPTIONAL 8 X 48 ELECTRONIC CAPTION

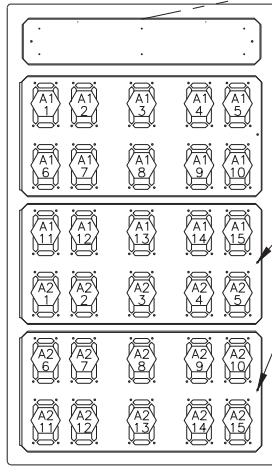

REMOVE THESE SCREWS TO ACCESS DRIVER THROUGH HINGED DOOR.

FRONT VIEW

ADDRESS INFORMATION

LEFT STATS SECTION		RIGHT STATS SECTION	
DRIVER:	A1	DRIVER:	A1
ADDRESS:	23	ADDRESS:	25
DRIVER:	A2	DRIVER:	A2
ADDRESS:	24	ADDRESS:	26

OPTIONAL ELECTRONIC CAPTION, ADDRESS 223 AND HOME/GUEST ADDRESS SWITCH SET TO GUEST (ON).

COMPONENT LOCATIONS:

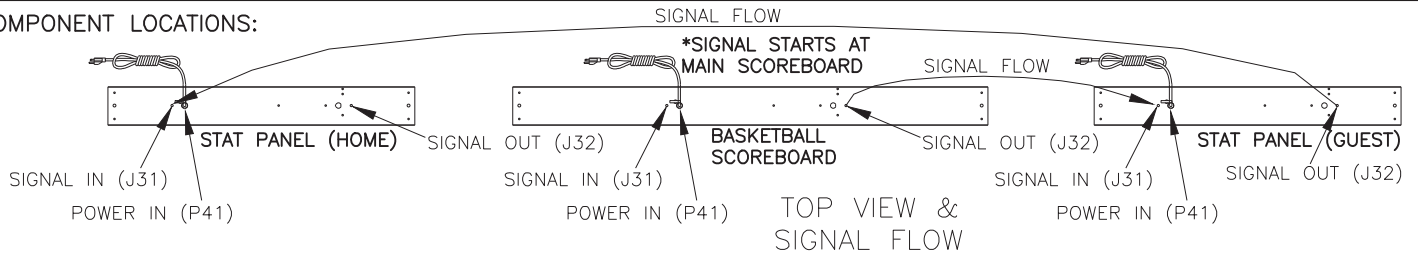

TOP VIEW & SIGNAL FLOW

*SIGNAL INSTRUCTIONS:

- SIGNAL FROM SOURCE LANDS TO MAIN BASKETBALL SCOREBOARD FIRST.
- THEN OUT FROM SCOREBOARD TO IN ON STATS PANEL.
- AND OUT FROM STATS PANEL TO IN ON OTHER STATS PANEL.

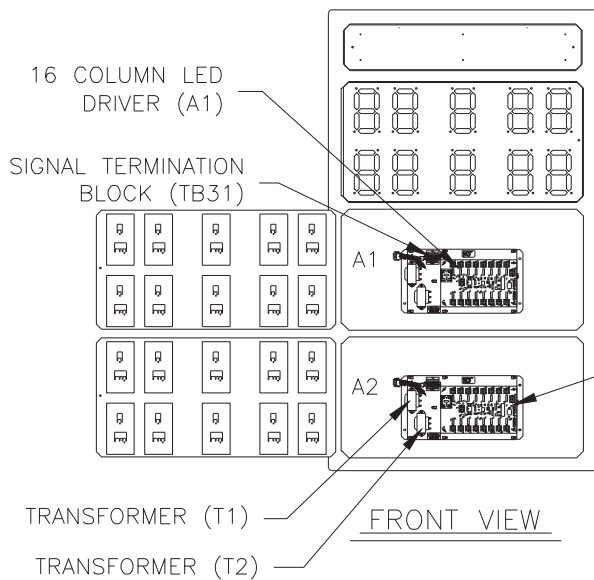

FRONT VIEW

DIGITS

PLYR: 7" AMBER
FLS: 7" RED
PTS: 7" RED

TUFF SPORT™ & COLORSMART™ ARE TRADEMARKS OF DAKTRONICS

<p>DAKTRONICS, INC. BROOKINGS, SD 57006</p>	<p>THE CONCEPTS EXPRESSED AND DETAILS SHOWN ON THIS DRAWING ARE CONFIDENTIAL AND PROPRIETARY. DO NOT REPRODUCE BY ANY MEANS WITHOUT THE EXPRESSED WRITTEN CONSENT OF DAKTRONICS, INC. COPYRIGHT 2012 DAKTRONICS, INC.</p>	
	<p>DO NOT SCALE DRAWING</p>	
<p>PROJ: TUFF SPORT COLORSMART SCOREBOARDS</p>		
<p>TITLE: ELECTRICAL AND SIGNAL SPEC- MCAST- SD-3102</p>		
<p>DESIGN: JFELDHA</p>	<p>DRAWN: JFELDHA</p>	<p>DATE: 21 AUG 06</p>
<p>SCALE: 1=30</p>		
<p>SHEET</p>	<p>REV</p>	<p>JOB NO:</p>
<p>02</p>	<p>1389</p>	<p>FUNC-TYPE-SIZE</p>
		<p>E-10-A</p>
		<p>282968</p>

REV 02	DATE: 02 MAR 12	ADDED SCBD AND SIGNAL ROUTING.	BY: SMB
REV 01	DATE: 21 AUG 09	CORRECT TITLE OF OPTIONAL "TNMC" TO ELECTRONIC CAPTION. ADDED ADDRESS TO CHART.	BY: MWM

SD-3103

DIGIT, SIGNAL AND POWER SPECIFICATIONS:

NOTES:

OPTIONAL 8 X 48 TNMC

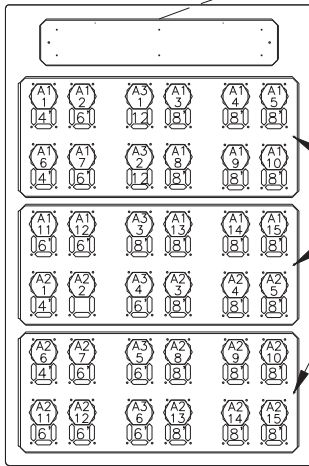

FRONT VIEW

REMOVE THESE SCREWS TO ACCESS DRIVER THROUGH HINGED DOOR.

1. USE MINIMUM OF 22AWG, SHIELDED, TWO CONDUCTOR CABLE FOR SIGNAL TERMINATION.

2. THE NUMBER LISTED BY EACH DIGIT INDICATES THE DIGIT DESIGNATION IN RELATION TO THE LED DRIVER.

3. **DO NOT WORK ON ENERGIZED DISPLAY UNLESS YOU ARE A CERTIFIED ELECTRICIAN OR DIRECTED BY DAKTRONICS.**

4. THE SCOREBOARD IS SHOWN WITH UNIVIEW DIGIT TECHNOLOGY. SEE DRAWING A-158550 FOR MORE DETAILS.

ADDRESS INFORMATION			
LEFT STATS SECTION		RIGHT STATS SECTION	
DRIVER:	A1	DRIVER:	A1
ADDRESS:	23	ADDRESS:	25
DRIVER:	A2	DRIVER:	A2
ADDRESS:	24	ADDRESS:	26
DRIVER:	A3	DRIVER:	A3
ADDRESS:	27	ADDRESS:	28
OPTIONAL ELECTRONIC CAPTION, ADDRESS 223 AND HOME/GUEST ADDRESS SWITCH SET TO GUEST (ON).			

COMPONENT LOCATIONS:

SIGNAL FLOW

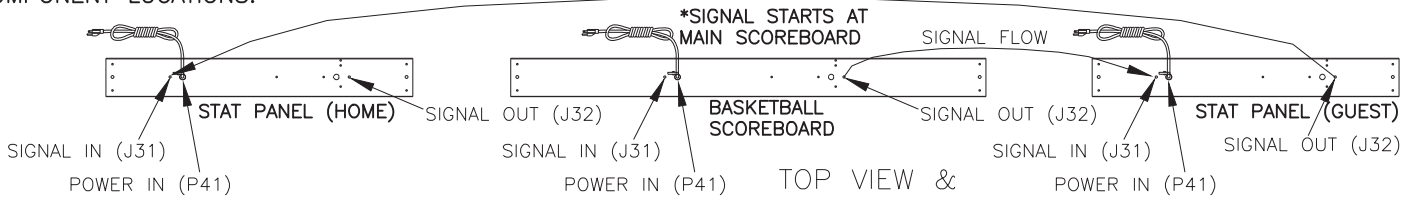

TOP VIEW & SIGNAL FLOW

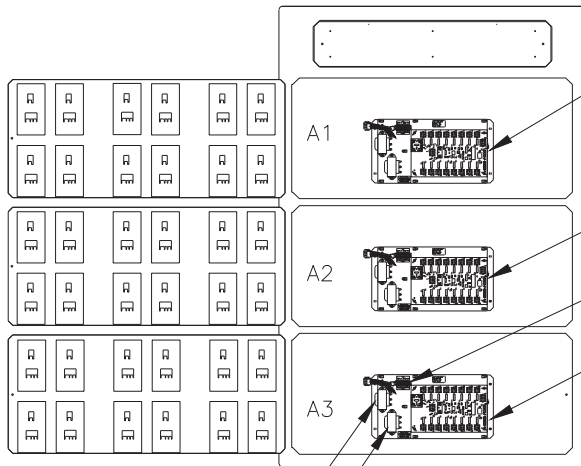

TRANSFORMER (T1)
TRANSFORMER (T2)

FRONT VIEW

- 16 COLUMN LED DRIVER (A1)
- 16 COLUMN LED DRIVER (A2)
- SIGNAL TERMINATION BLOCK (TB31)
- 16 COLUMN LED DRIVER (A3)

***SIGNAL INSTRUCTIONS:**

- SIGNAL FROM SOURCE LANDS TO MAIN BASKETBALL SCOREBOARD FIRST.
- THEN OUT FROM SCOREBOARD TO IN ON STATS PANEL.
- AND OUT FROM STATS PANEL TO IN ON OTHER STATS PANEL.

DIGITS

PLYR: 7" AMBER
FLS: 7" RED
PTS: 7" RED

TUFF SPORT™ & COLORSMART™ ARE TRADEMARKS OF DAKTRONICS

<p>DAKTRONICS, INC. BROOKINGS, SD 57006</p>	<p>THE CONCEPTS EXPRESSED AND DETAILS SHOWN ON THIS DRAWING ARE CONFIDENTIAL AND PROPRIETARY. DO NOT REPRODUCE BY ANY MEANS WITHOUT THE EXPRESSED WRITTEN CONSENT OF DAKTRONICS, INC. COPYRIGHT 2012 DAKTRONICS, INC.</p>	
	<p>DO NOT SCALE DRAWING</p>	
<p>PROJ: TUFF SPORT COLORSMART SCOREBOARDS</p>		
<p>TITLE: ELECTRICAL AND SIGNAL SPEC- MCAST- SD-3103</p>		
<p>DESIGN: JFELDHA</p>	<p>DRAWN: JFELDHA</p>	<p>DATE: 21 AUG 06</p>
<p>SCALE: 1=30</p>		
<p>SHEET</p>	<p>REV</p>	<p>JOB NO:</p>
<p>01</p>	<p>01</p>	<p>1389</p>
<p>FUNC-TYPE-SIZE</p>		<p>282970</p>
<p>E-10-A</p>		

REV	DATE:	ADDED SCBD AND SIGNAL ROUTING.	BY:
01	02 MAR 12		SMB

BB-3142

DIGIT, SIGNAL AND POWER SPECIFICATIONS:

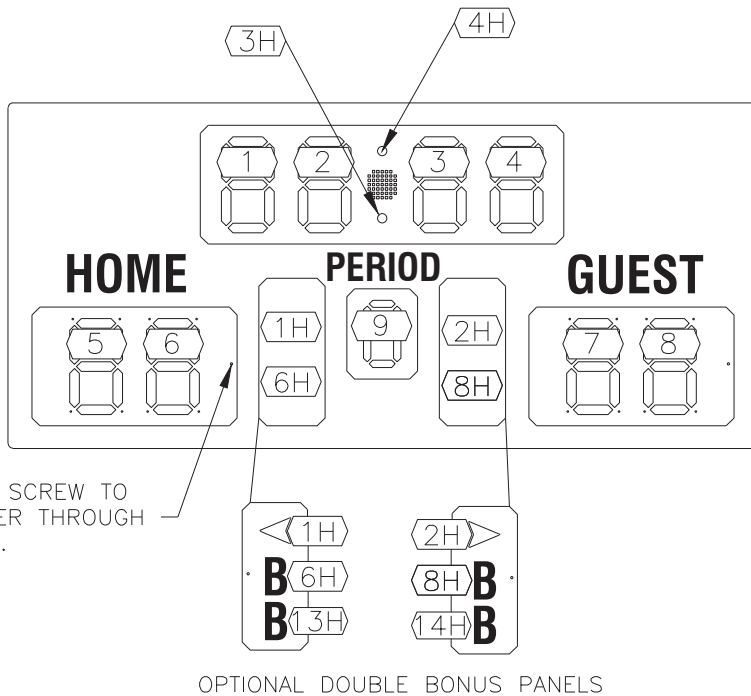

REMOVE THIS SCREW TO ACCESS DRIVER THROUGH HINGED DOOR.

OPTIONAL DOUBLE BONUS PANELS

FRONT VIEW

NOTES:

1. USE MINIMUM OF 22AWG, SHIELDED, TWO CONDUCTOR CABLE FOR SIGNAL TERMINATION.
2. THE NUMBER LISTED BY EACH DIGIT INDICATES THE DIGIT DESIGNATION IN RELATION TO THE LED DRIVER.
3. DO NOT WORK ON ENERGIZED DISPLAY UNLESS YOU ARE A CERTIFIED ELECTRICIAN OR DIRECTED BY DAKTRONICS.
4. THE SCOREBOARD IS SHOWN WITH UNIVIEW DIGIT TECHNOLOGY. SEE DRAWING A-158550 FOR MORE DETAILS.

ADDRESS INFORMATION	
DRIVER:	A1
ADDRESS:	17

COMPONENT LOCATIONS:

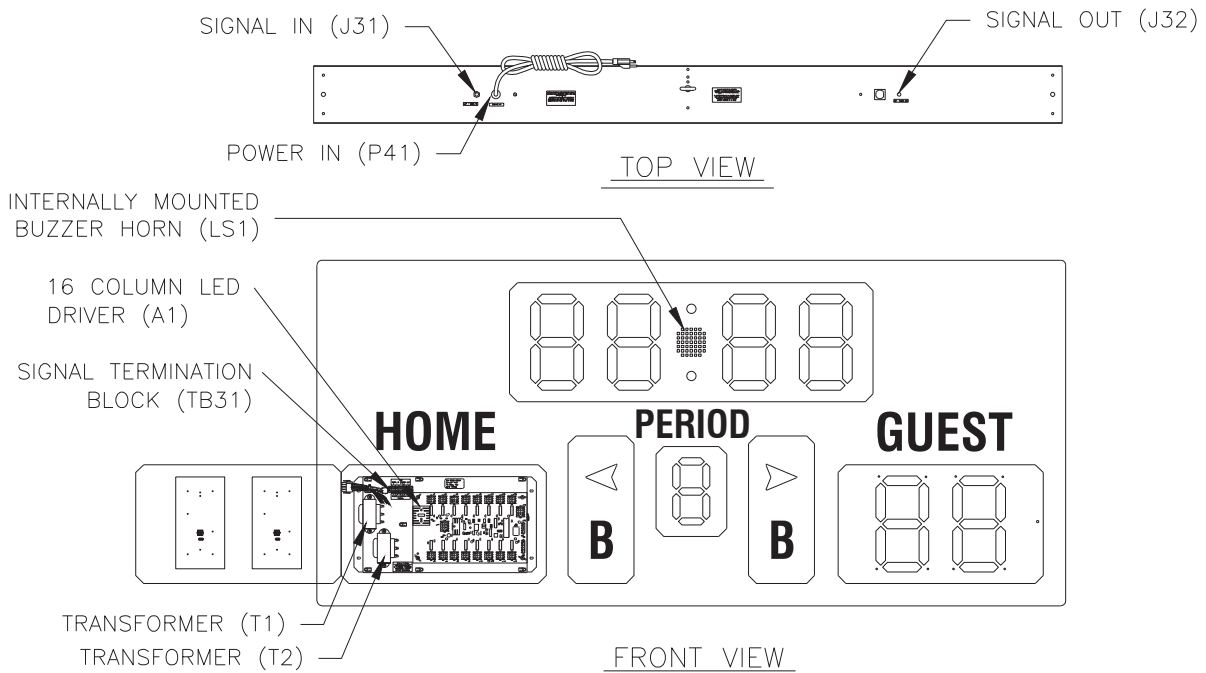

TOP VIEW

FRONT VIEW

DIGITS:

- CLOCK: 10" AMBER/RED/GREEN
- SCORE: 10" RED/AMBER/GREEN
- PERIOD: 7" AMBER
- POSSESSION: 3" RED ARROW
- BONUS: 4" AMBER B & 3" ARROW

TUFF SPORT™ & COLORSMART™ ARE TRADEMARKS OF DAKTRONICS

DAKTRONICS, INC. BROOKINGS, SD 57006 DO NOT SCALE DRAWING	THE CONCEPTS EXPRESSED AND DETAILS SHOWN ON THIS DRAWING ARE CONFIDENTIAL AND PROPRIETARY. DO NOT REPRODUCE BY ANY MEANS WITHOUT THE EXPRESSED WRITTEN CONSENT OF DAKTRONICS, INC. COPYRIGHT 2011 DAKTRONICS, INC.	
	PROJ:COLORSMART™ SCOREBOARDS TITLE:ELECTRICAL & SIGNAL SPEC, MCAST-BB-3142	
DESIGN:CBRECZI SCALE: 1=20	DRAWN:LMIX REV: 02 SHEET: 02	DATE: 05 JAN 10 X JOB NO: P1389 FUNC-TYPE-SIZE: E-10-A
		956953

REV 02	DATE: 08 APR 11	UPDATED DOUBLE BONUS OPTIONS	BY: KDD
REV 01	DATE: 26 JAN 10	CHANGED TO 14 SEG DIGITS CHANGED SCALE FROM 1=40 TO 1=20	BY: JLR

BB-3125 & BB-3126 FACE SECTION

DIGIT, SIGNAL AND POWER SPECIFICATIONS:

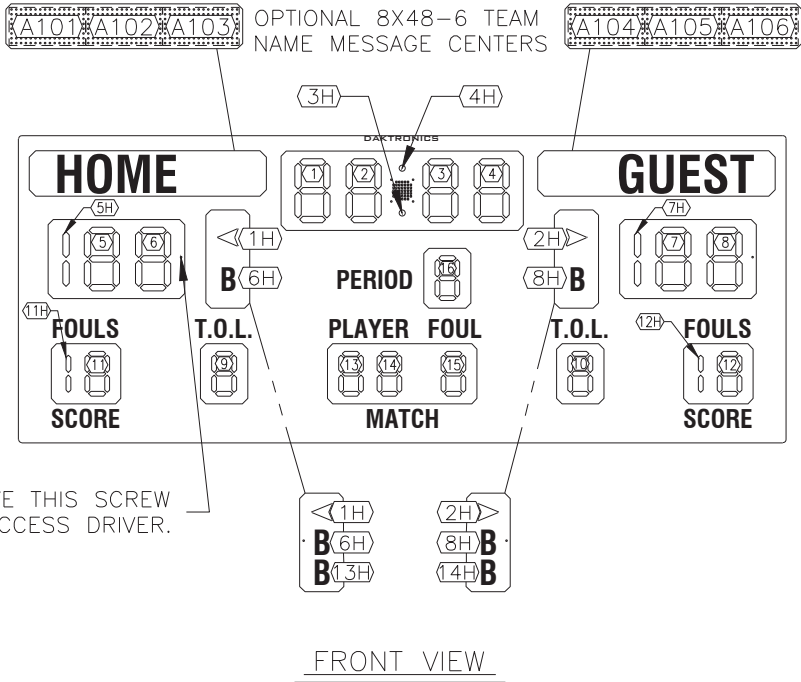

NOTES:

1. USE MINIMUM OF 22AWG, SHIELDED, TWO CONDUCTOR CABLE FOR SIGNAL TERMINATION.
2. THE NUMBER LISTED BY EACH DIGIT INDICATES THE LED DRIVER AND DIGIT DESIGNATION IN RELATION TO THE LED DRIVER.
3. DO NOT WORK ON ENERGIZED DISPLAY UNLESS YOU ARE A CERTIFIED ELECTRICIAN OR DIRECTED BY DAKTRONICS.
4. THE SCOREBOARD IS SHOWN WITH UNIVIEW DIGIT TECHNOLOGY. SEE DRAWING A-158550 FOR MORE DETAILS.

ADDRESS INFORMATION	
DRIVER:	A1
ADDRESS:	17

COMPONENT LOCATION:

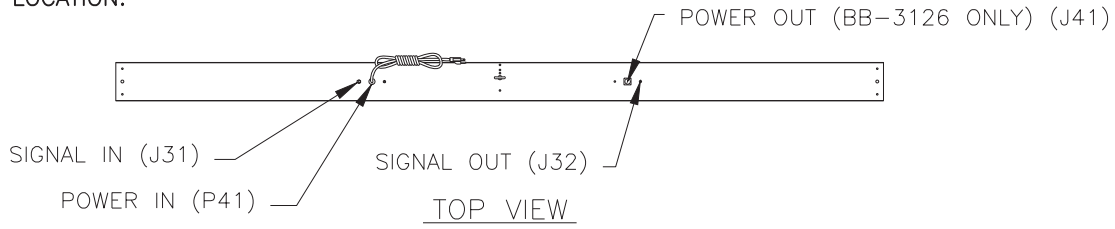

SIGNAL TERMINATION BLOCK (TB31)

16 COLUMN LED DRIVER (A1)

TRANSFORMER (T1)
TRANSFORMER (T2)

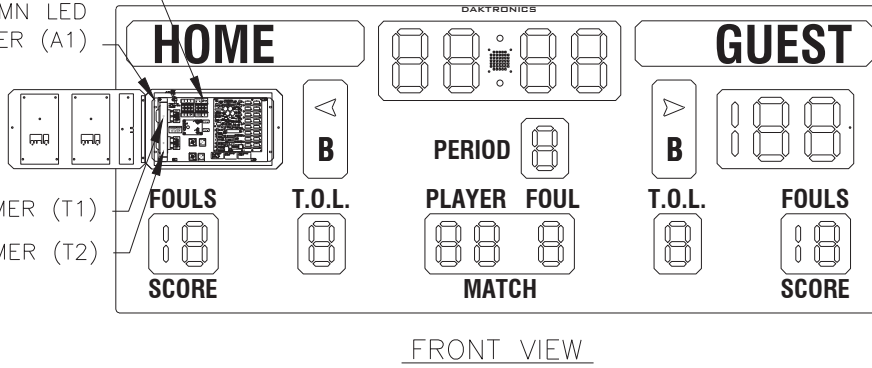

DIGITS:

- CLOCK: 10" AMBER/RED/GREEN
- SCORE: 10" RED/AMBER/GREEN
- PERIOD: 7" AMBER
- TEAM FOULS: 7" RED
- TIME OUTS LEFT: 7" AMBER
- PLAYER/FOUL: 7" AMBER
- POSSESSION: 3" RED ARROW
- BONUS: 4" AMBER B & 3" ARROW

TUFF SPORT™ & COLORSMART™ ARE TRADEMARKS OF DAKTRONICS

	DAKTRONICS, INC. BROOKINGS, SD 57006	THE CONCEPTS EXPRESSED AND DETAILS SHOWN ON THIS DRAWING ARE CONFIDENTIAL AND PROPRIETARY. DO NOT REPRODUCE BY ANY MEANS WITHOUT THE EXPRESSED WRITTEN CONSENT OF DAKTRONICS, INC. COPYRIGHT 2011 DAKTRONICS, INC.
	DO NOT SCALE DRAWING	
PROJ.: COLORSMART™ SCOREBOARDS TITLE: ELECTRICAL & SIGNAL SPEC, MCAST-BB-3125& BB-3126 DESIGN: BPETERSON DRAWN: LMIX DATE: 05 JAN 10 SCALE: 1 = 30		
REV 01 DATE: 08 APR 11 UPDATED DOUBLE BONUS OPTIONS BY: KDD	SHEET REV 01 JOB NO: P1389 FUNC-TYPE-SIZE: E-10-A	956998

BB-3123 & BB-3124 FACE

DIGIT, SIGNAL AND POWER SPECIFICATIONS:

NOTES:

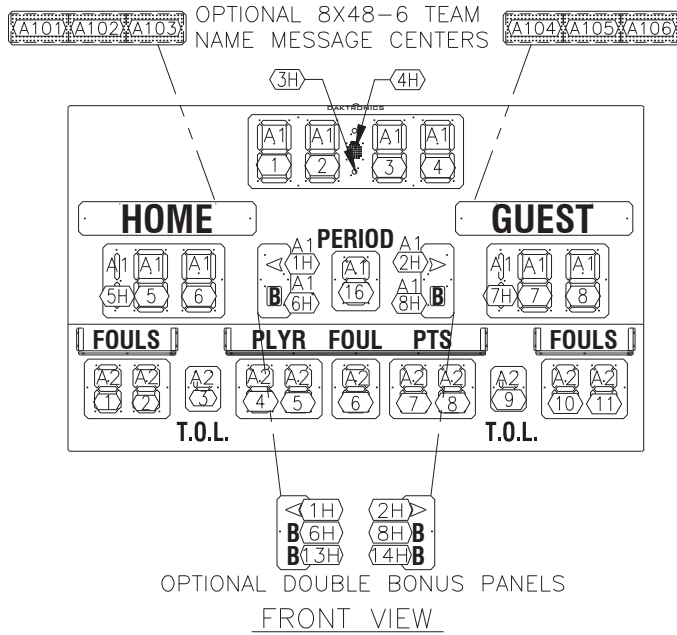

1. USE MINIMUM OF 22AWG, SHIELDED, TWO CONDUCTOR CABLE FOR SIGNAL TERMINATION.
2. THE NUMBER LISTED BY EACH DIGIT INDICATES THE DIGIT DESIGNATION IN RELATION TO THE LED DRIVER.
3. **DO NOT WORK ON ENERGIZED DISPLAY UNLESS YOU ARE A CERTIFIED ELECTRICIAN OR DIRECTED BY DAKTRONICS.**
4. THE SCOREBOARD IS SHOWN WITH COLORSMART™ DIGIT TECHNOLOGY. SEE DRAWING A-158550 FOR MORE DETAILS.

ADDRESS INFORMATION	
DRIVER:	A1
ADDRESS:	17
ADDRESS INFORMATION	
DRIVER:	A2
ADDRESS:	14

COMPONENT LOCATIONS:

DIGITS:

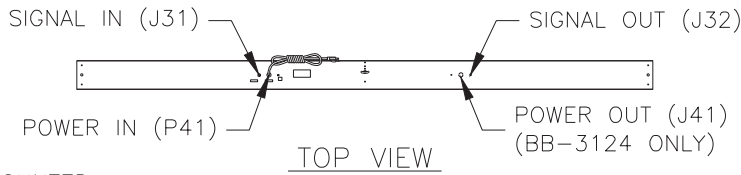

- CLOCK: 13" AMBER/RED/GREEN
- FOULS: 10" RED
- SCORE: 13" RED/AMBER/GREEN
- PERIOD: 10" AMBER
- TOL: 7" AMBER
- PLYR/FOUL/PTS: 10" AMBER
- POSSESSION: 3" RED ARROW
- BONUS: 4" AMBER B

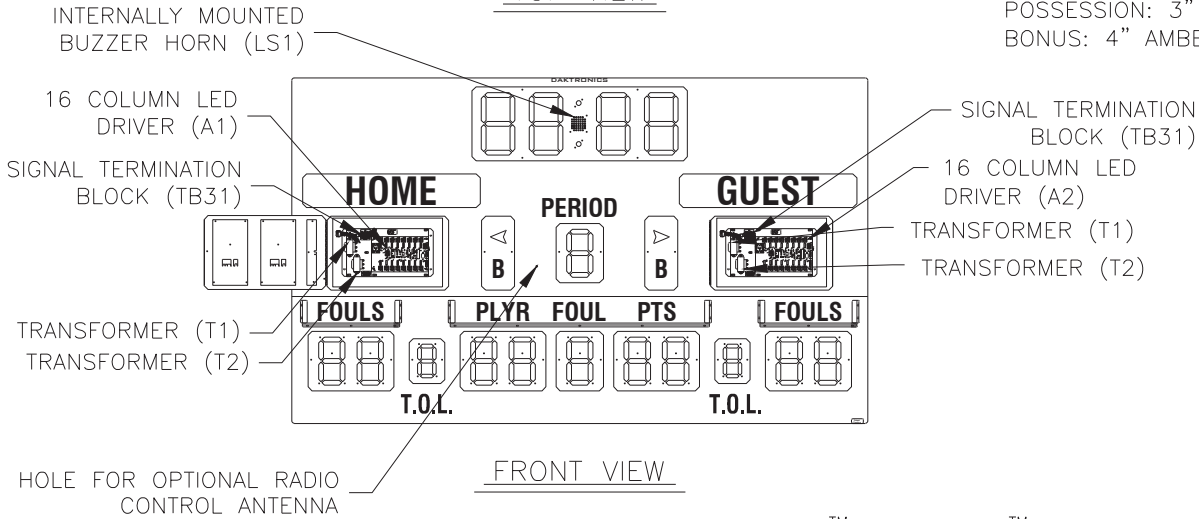

TUFF SPORT™ & COLORSMART™ ARE TRADEMARKS OF DAKTRONICS

	DAKTRONICS, INC. BROOKINGS, SD 57006		THE CONCEPTS EXPRESSED AND DETAILS SHOWN ON THIS DRAWING ARE CONFIDENTIAL AND PROPRIETARY. DO NOT REPRODUCE BY ANY MEANS WITHOUT THE EXPRESSED WRITTEN CONSENT OF DAKTRONICS, INC. COPYRIGHT 2011 DAKTRONICS, INC.	
	DO NOT SCALE DRAWING			
PROJ: TUFF SPORT™ SCOREBOARDS				
TITLE: ELECTRICAL AND SIGNAL SPEC; BB-3123/3124				
DESIGN: DOPPELT		DRAWN: ZRYKHUS		DATE: 16 AUG 11
SCALE: 1 = 40				
SHEET	REV	JOB NO:	FUNC-TYPE-SIZE	1065749
	00	P1237	E-10-A	

BB-3114

DIGIT, SIGNAL AND POWER SPECIFICATIONS:

NOTES:

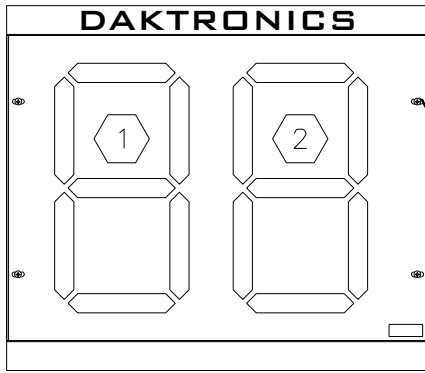

FRONT VIEW

TO GAIN ACCESS TO THE INTERIOR COMPONENTS, REMOVE THE FOUR SCREWS SECURING THE FACE PANEL.

1. USE MINIMUM OF 22AWG, SHIELDED, TWO CONDUCTOR CABLE FOR SIGNAL TERMINATION.

2. THE NUMBER LISTED BY EACH DIGIT INDICATES THE DIGIT DESIGNATION IN RELATION TO THE LED DRIVER.

3. **DO NOT WORK ON ENERGIZED DISPLAY UNLESS YOU ARE A CERTIFIED ELECTRICIAN OR DIRECTED BY DAKTRONICS.**

4. THE SCOREBOARD IS SHOWN WITH UNIVIEW DIGIT TECHNOLOGY. SEE DRAWING A-158550 FOR MORE DETAILS.

ADDRESS INFORMATION	
DRIVER:	A1
ADDRESS:	2

COMPONENT LOCATIONS:

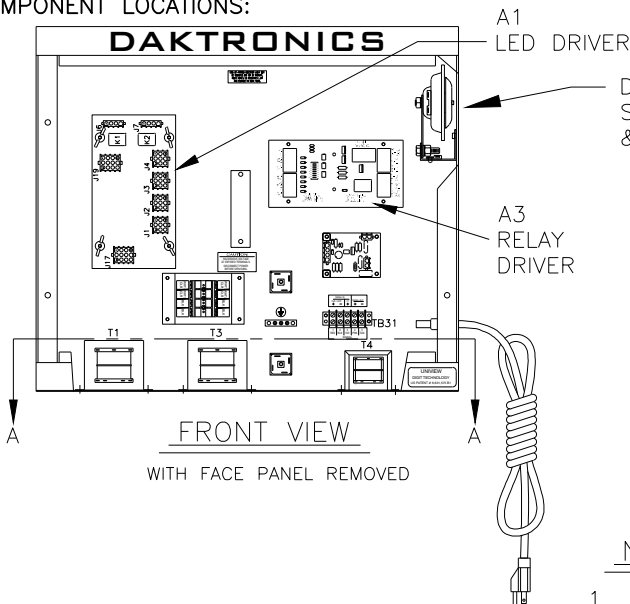

FRONT VIEW
WITH FACE PANEL REMOVED

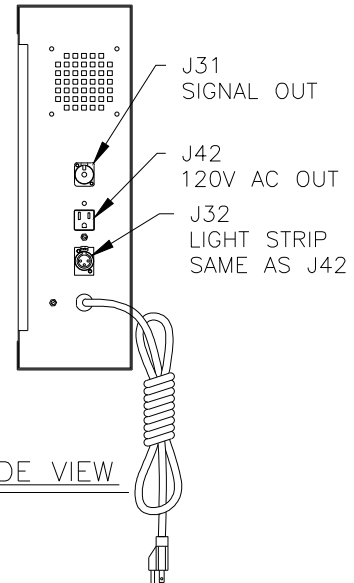

SIDE VIEW

NOTES:

1. DS1 IS CONNECTED TO THE SHOT CLOCK HORN SEGMENT.
2. J42 IS CONNECTED TO THE GAME CLOCK=0 SEGMENT.
3. TO CHANGE DEFAULT FUNCTION OF HORN, RECONNECT GRAY PIGTAIL WIRES AT TB1 ON A3 TO A DIFFERENT VALUE.
4. SEE DRAWING A-282960 FOR COMPONENT LOCATIONS PRIOR TO THE RELAY BOARD BEING ADDED TO THIS ASSEMBLY.

*5. IN DECEMBER 2012, TRANSFORMER (T4) WAS REPLACED WITH A POWER SUPPLY. REFER TO FINAL ASSEMBLY DRAWING FOR CURRENT COMPONENT LOCATIONS. DWG-1061635.

TUFF SPORT™ & COLORSMART™ ARE TRADEMARKS OF DAKTRONICS

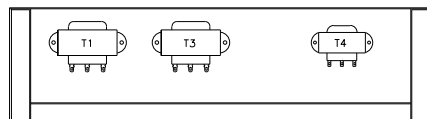

SECTION: A-A

DAKTRONICS, INC. BROOKINGS, SD 57006	THE CONCEPTS EXPRESSED AND DETAILS SHOWN ON THIS DRAWING ARE CONFIDENTIAL AND PROPRIETARY. DO NOT REPRODUCE BY ANY MEANS WITHOUT THE EXPRESSED WRITTEN CONSENT OF DAKTRONICS, INC. COPYRIGHT 2011 DAKTRONICS, INC.		
	DO NOT SCALE DRAWING		
PROJ: TUFF SPORT COLORSMART SCOREBOARDS			
TITLE: ELECTRICAL AND SIGNAL SPEC; MCAST, BB-3114			
DESIGN: CHAMILT		DRAWN: CHAMILT	DATE: 23 AUG 11
SCALE: 1:10			
SHEET	REV	JOB NO:	FUNC-TYPE-SIZE
	01	P1237	E-10-A
			1066728

REV	DATE:	ADDED NOTE #4 & #5	BY:
01	4 JAN 13		MBJ

BB-3115

NOTES:

DIGIT, SIGNAL AND POWER SPECIFICATIONS:

TO GAIN ACCESS TO THE INTERIOR COMPONENTS, REMOVE THE SCREWS SECURING THE FACE PANEL. DOOR SWINGS DOWN ON HINGE.

1. USE MINIMUM OF 22AWG, SHIELDED, TWO CONDUCTOR CABLE FOR SIGNAL TERMINATION.

2. THE NUMBER LISTED BY EACH DIGIT INDICATES THE DIGIT DESIGNATION IN RELATION TO THE LED DRIVER.

3. DO NOT WORK ON ENERGIZED DISPLAY UNLESS YOU ARE A CERTIFIED ELECTRICIAN OR DIRECTED BY DAKTRONICS.

4. THE SCOREBOARD IS SHOWN WITH UNIVIEW DIGIT TECHNOLOGY. SEE DRAWING A-158550 FOR MORE DETAILS.

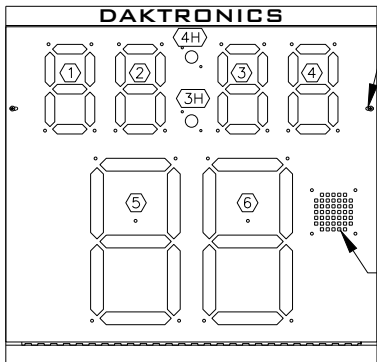

DS1 (HORN) DEFAULT SETTING: GAME HORN & SHOT HORN

FRONT VIEW

ADDRESS INFORMATION

DRIVER:	A1
ADDRESS:	01

COMPONENT LOCATIONS:

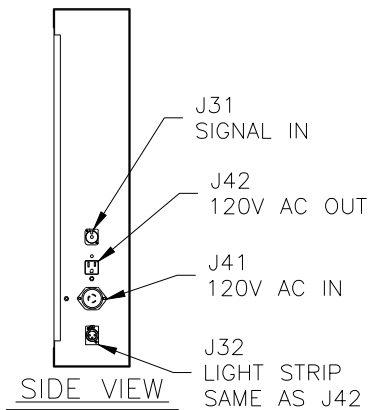
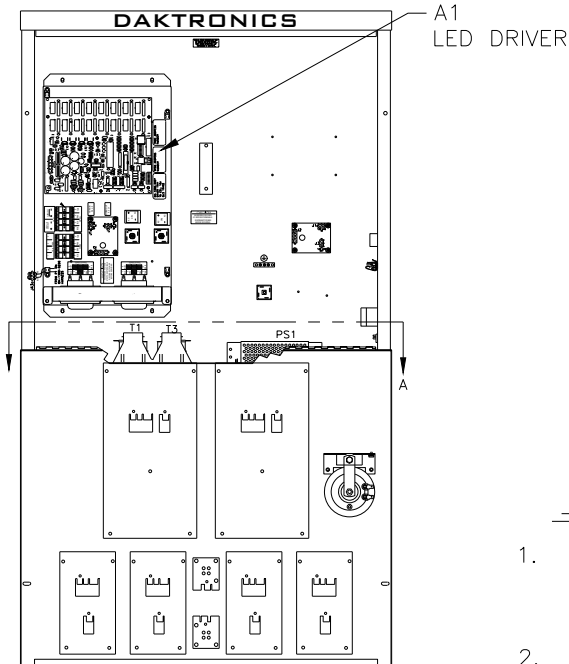

SIDE VIEW

NOTES:

1. DS1 IS CONNECTED TO J27 ON THE A1 DRVR FOR SHOT HORN. TO CHANGE FUNCTION TO GAME HORN RECONNECT HARNESS TO J26.
2. LIGHT STRIP OPTION IS CONNECTED TO J29 ON A1 DRVR.
3. VH1 LED CLUSTER ON ALL FACE PANELS IS CONNECTED TO J28 ON A1 DRVR.
4. SEE DRAWING A-282962 FOR PRIOR COMPONENT LOCATIONS.

FRONT VIEW

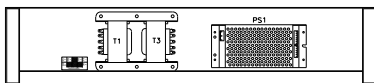

SECTION: A-A

TUFF SPORT™ & COLORSMART™ ARE TRADEMARKS OF DAKTRONICS

	DAKTRONICS, INC. BROOKINGS, SD 57006	THE CONCEPTS EXPRESSED AND DETAILS SHOWN ON THIS DRAWING ARE CONFIDENTIAL AND PROPRIETARY. DO NOT REPRODUCE BY ANY MEANS WITHOUT THE EXPRESSED WRITTEN CONSENT OF DAKTRONICS, INC. COPYRIGHT 2013 DAKTRONICS, INC.
	DO NOT SCALE DRAWING	
PROJ: TUFF SPORT COLORSMART SCOREBOARDS		
TITLE: ELECTRICAL AND SIGNAL MCAST, BB-3115		
DESIGN: CHAMILT	DRAWN: MJOHNSO	DATE: 7 JAN13
SCALE: 1=15		
SHEET	REV	JOB NO:
	00	P1237
FUNC-TYPE-SIZE		1123280
E-10-A		

Appendix C: Scoreboard Options

<i>Drawing Title</i>	<i>Drawing Number</i>
Backstop Mounting Suggestions	A-91230
Wiring for Shot Clock on Portable Backstop	A-98293
Advertising/Identification Display Mounting	A-147668
Suspension Lift Eye Installation	A-148644
12V DC Horn Option Installation.....	A-148960
T.O.L. Option Installation	A-149030
Changeable Team Name Caption Installation	A-150021
Corner Mounting	A-150831
ID or Ad Panel Mounting to Scoreboard	A-156134
Installation- MCAST- 6" Amber 8x48 TNMC	A-296610
Installation: Programmable Caption- 8x48-6"- MCAST	A-324099

CEILING MOUNTED BACKSTOPS
SUPPORTED BY TWO PIPES:

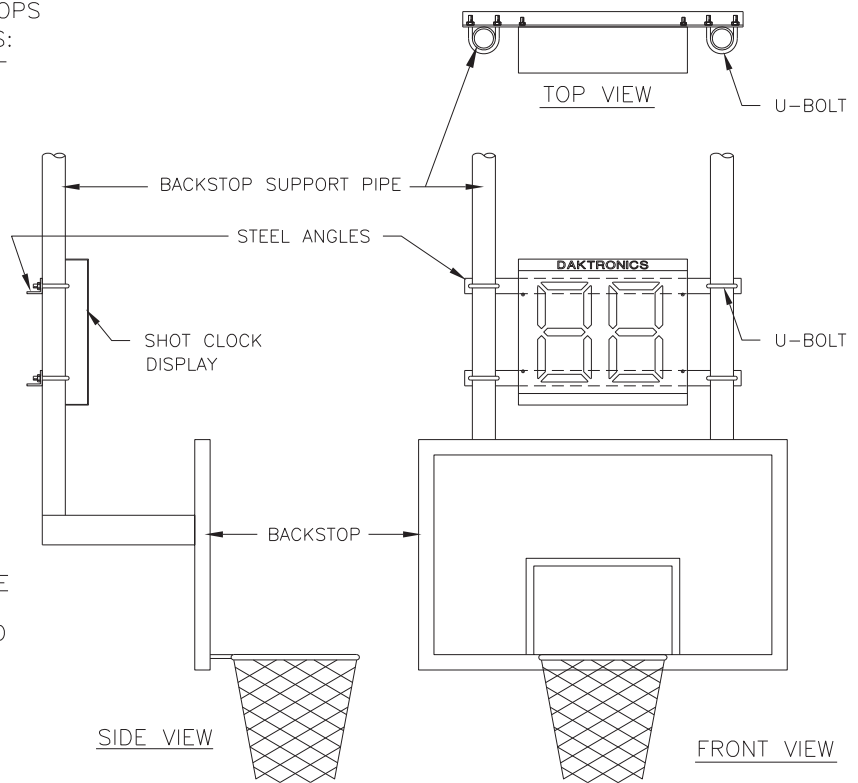

DAKTRONICS DOES NOT SUPPLY THE HARDWARE OR BRACKETS TO MOUNT SHOT CLOCK DISPLAYS TO BACKSTOPS. THE METHODS SHOWN ARE SUGGESTIONS FOR TWO COMMON BACKSTOP TYPES. DAKTRONICS, INC. IS NOT RESPONSIBLE FOR THE INTEGRITY OR SUITABILITY OF MOUNTING SYSTEMS MANUFACTURED AND INSTALLED BY OTHERS.

CEILING MOUNTED BACKSTOPS
SUPPORTED BY ONE PIPE OR POLE:

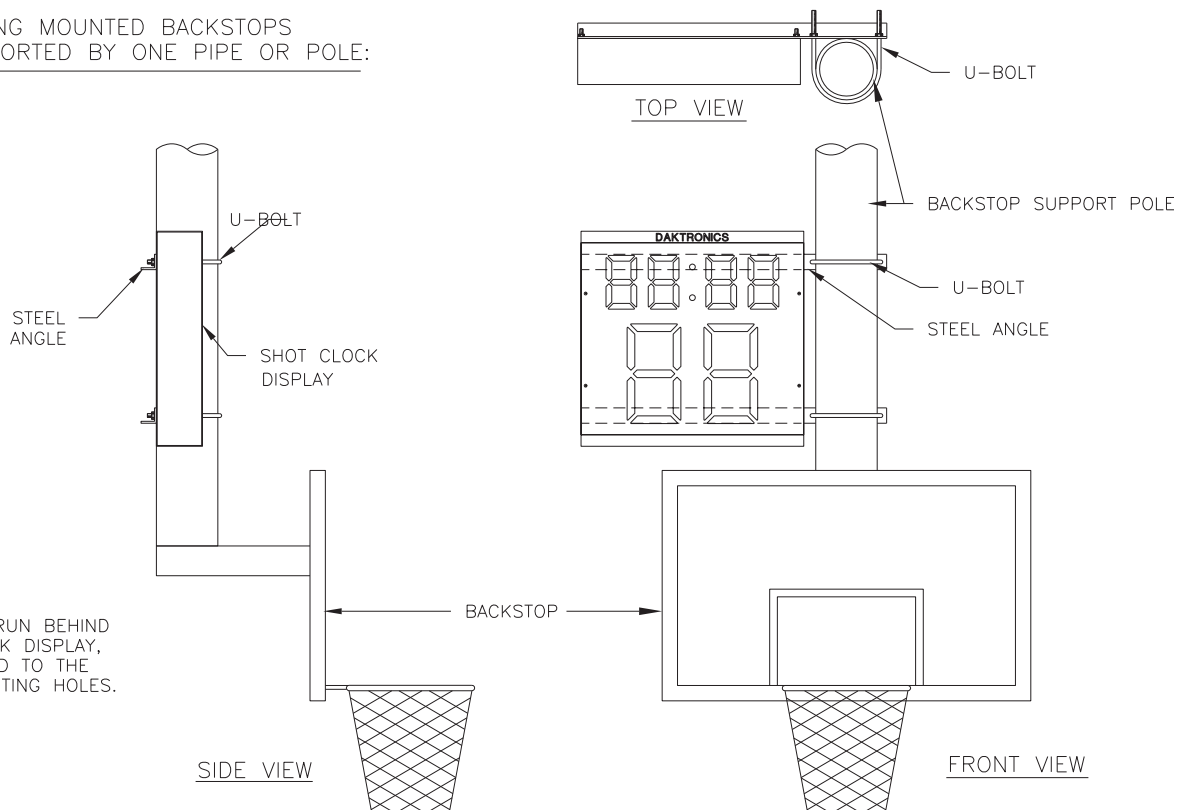

STEEL ANGLES RUN BEHIND THE SHOT CLOCK DISPLAY, AND ARE BOLTED TO THE DISPLAY'S MOUNTING HOLES.

DAKTRONICS, INC. BROOKINGS, SD 57006

PROJ:

TITLE: BACKSTOP MOUNTING SUGGESTIONS

DES. BY:

DRAWN BY: A VANBEMMEL

DATE: 13 MAR 97

REVISION

APPR. BY:

SCALE: NONE

1009-R10A-91230

REV.	DATE	DESCRIPTION	BY	APPR.

TWO-DIGIT SHOT CLOCK IS SHOWN.
THIS IS ALSO APPLICABLE TO 6-DIGIT
GAME/SHOT CLOCK MODEL BB-2015

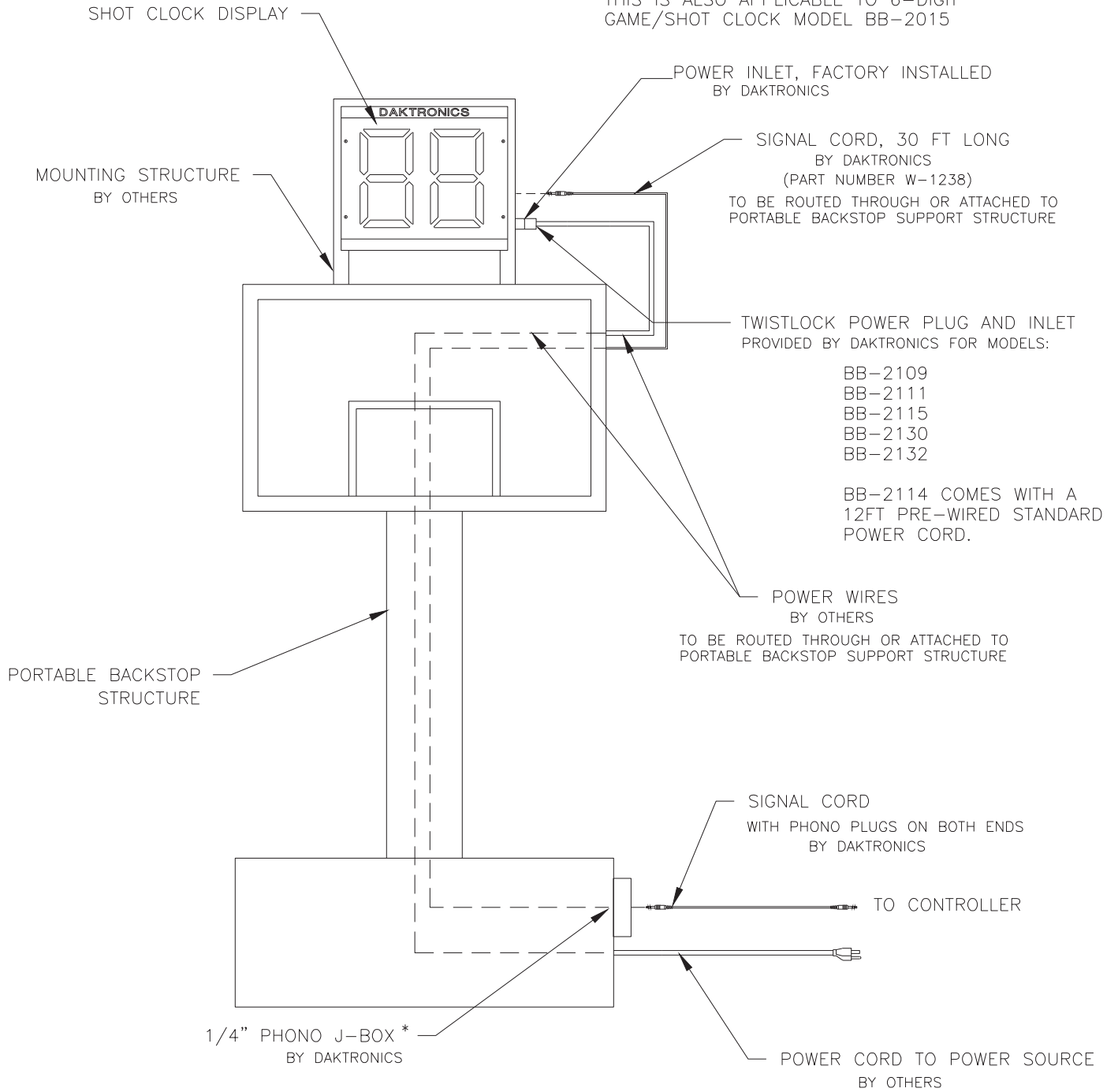

* SIGNAL CONNECTORS ARE 1/4" PHONO PLUGS.

 DAKTRONICS, INC. BROOKINGS, SD 57006 DO NOT SCALE DRAWING	THE CONCEPTS EXPRESSED AND DETAILS SHOWN ON THIS DRAWING ARE CONFIDENTIAL AND PROPRIETARY. DO NOT REPRODUCE BY ANY MEANS WITHOUT THE EXPRESSED WRITTEN CONSENT OF DAKTRONICS, INC. COPYRIGHT 2010 DAKTRONICS, INC.	
	PROJ: BASKETBALL SCOREBOARDS	

REV 03	DATE: 09 DEC 10	CHANGED WIRING FORMAT	BY: JJD
REV 2	DATE: 29 JUN 99	DELETED TABLE. ADDED NOTE ABOUT BB-2015	BY: AVB
REV 1	DATE: 10FEB98	ADDED NEW MODELS TO THE TABLE	BY: DDL

TITLE: WIRING FOR SHOT CLOCK ON PORTABLE BACKSTOP			
DESIGN: AVB	DRAWN: A VANBEMMEL	DATE: 07 NOV 97	
SCALE: NONE			
SHEET	REV	JOB NO:	FUNC-TYPE-SIZE
	03	P1009	R-04-A
			98293

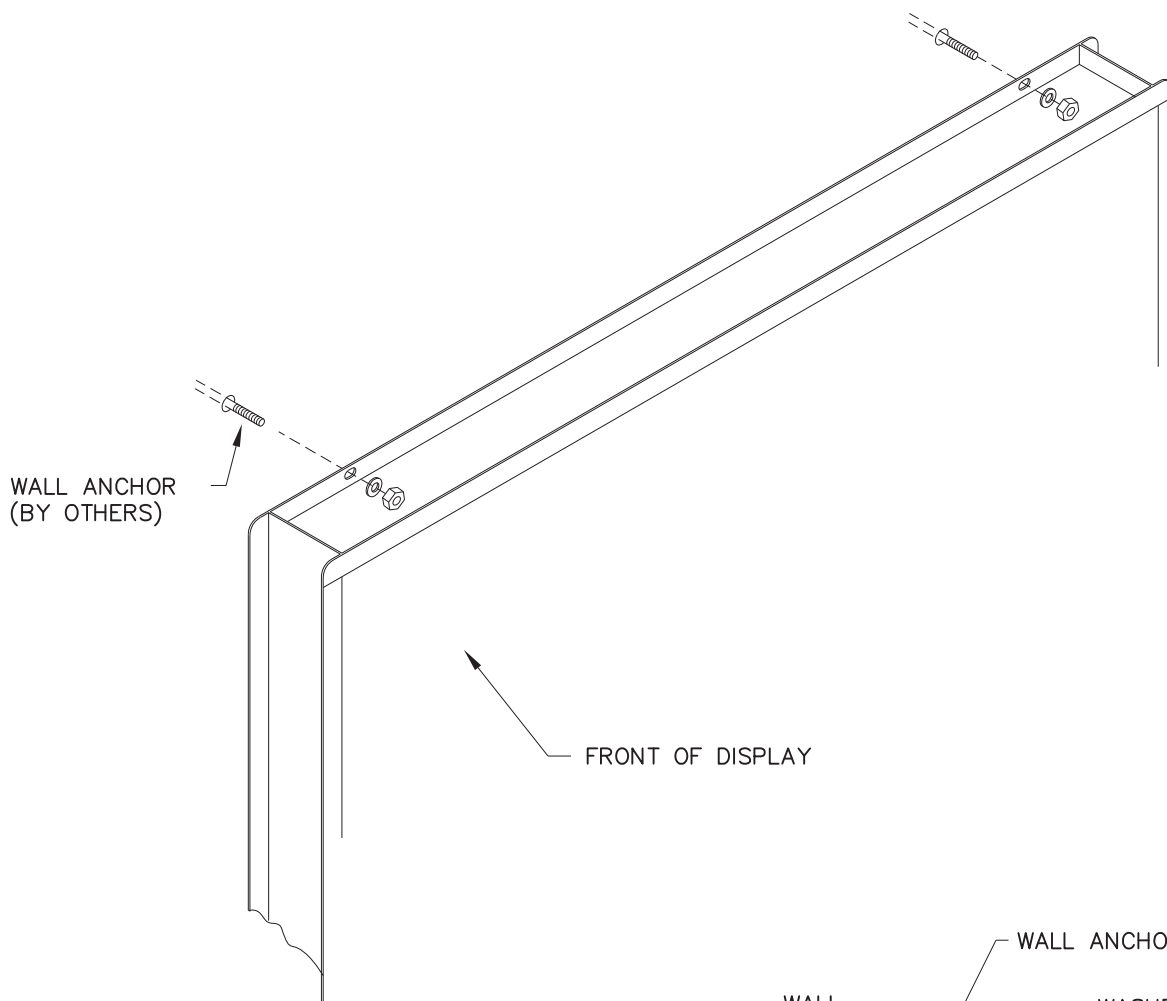

ATTACH THE DISPLAY TO THE WALL USING MOUNTING LOCATIONS PROVIDED. QUANTITY AND POSITION OF MOUNTING LOCATIONS WILL VARY WITH MODEL. USE THE APPROPRIATE ANCHORS FOR THE TYPE OF WALL.

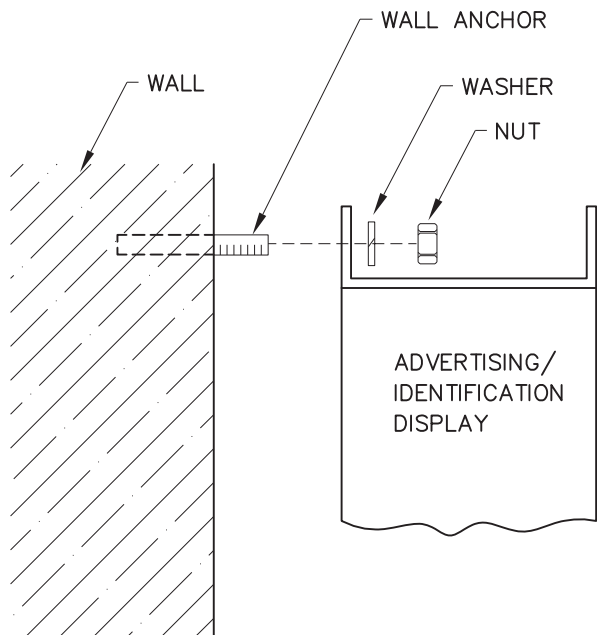

DAKTRONICS, INC. BROOKINGS, SD 57006	
PROJ:	
TITLE:	ADVERTISING/IDENTIFICATION DISPLAY MOUNTING
DES. BY:	JANDRE
DRAWN BY:	JANDRE
DATE:	16APR01
REVISION	APPR. BY:
	SCALE: NONE
1009-R10A-147668	

REV.	DATE	DESCRIPTION	BY	APPR.

MOUNT THE ANGLE (WITH 3/8" NUT) UNDER THE OVERHANG AT THE TOP OF THE SCOREBOARD. USE ONE ANGLE AT EACH END OF THE SCOREBOARD. SECURE WITH SCREWS INTO THE THREADED INSERTS MOUNTED IN THE SIDE OF THE SCOREBOARD.

INSTALL THE EYEBOLTS IN THE NUTS MOUNTED IN THE ANGLES.

ATTACH SUSPENSION CABLES TO EACH EYEBOLT WITH A SHACKLE (CLEVIS) AND PIN.

DAKTRONICS RECOMMENDS THAT TWO CABLES BE USED AT EACH END OF THE SCOREBOARD FOR REDUNDANCY. CABLES DIVERGE TO MINIMIZE SWINGING.

CABLES AND HARDWARE MUST BE SPECIFIED BY A LICENSED ENGINEER. THIS INSTALLATION METHOD MUST NOT BE USED TO SUPPORT SCOREBOARD WITH MESSAGE CENTERS AND BACKLIT AD PANELS ATTACHED.

TOTAL WEIGHT OF SCOREBOARD AND ATTACHED ACCESSORIES MUST NOT EXCEED 500 LB.

SUSPENSION HARDWARE IS FOR THE TOP OF THE SCOREBOARD ONLY. SCOREBOARD INSTALLATION WITH AD PANEL MUST NOT BE SUSPENDED FROM THE AD PANEL. THE SCOREBOARD MUST BE AT THE TOP.

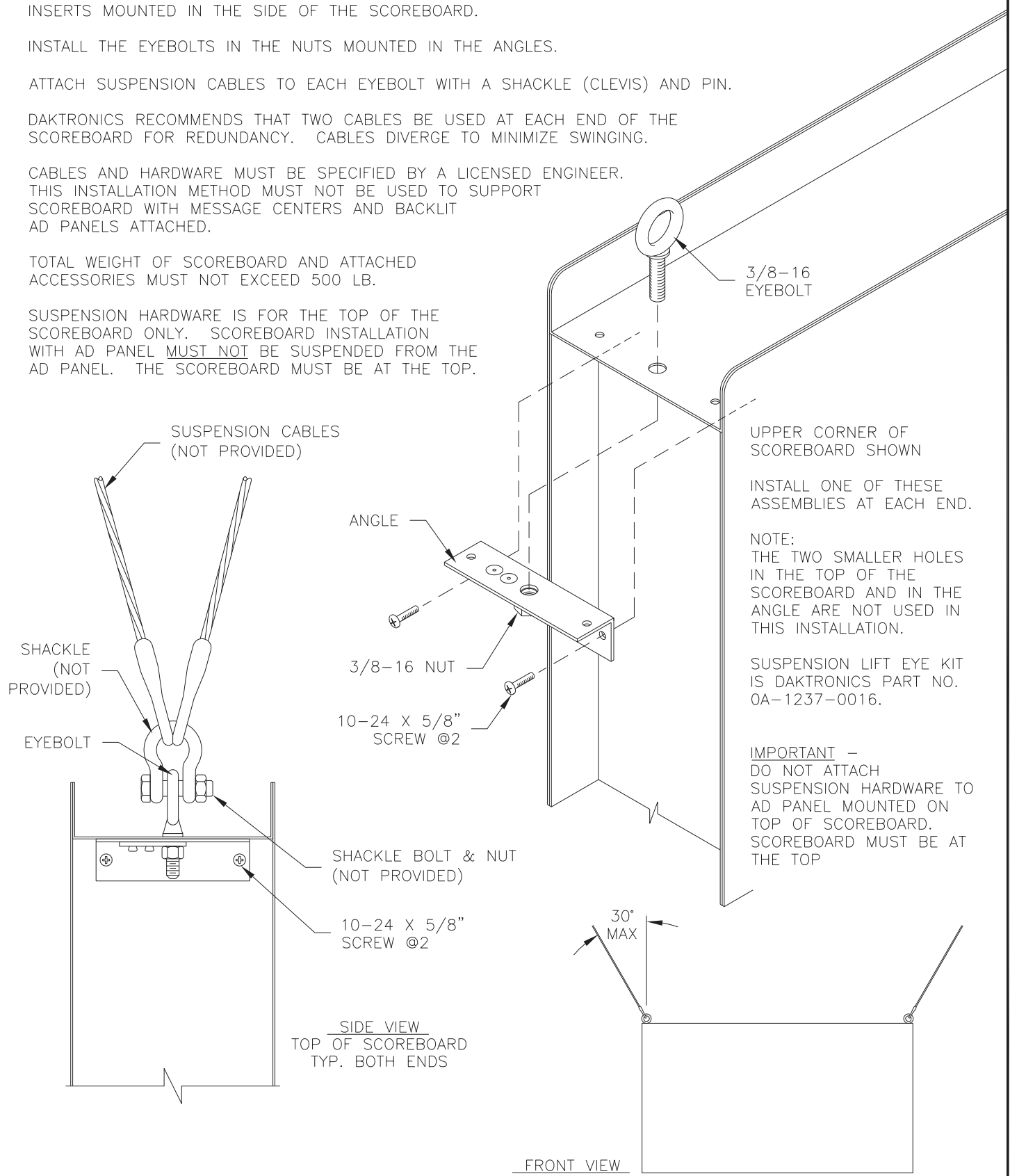

UPPER CORNER OF SCOREBOARD SHOWN
INSTALL ONE OF THESE ASSEMBLIES AT EACH END.

NOTE:
THE TWO SMALLER HOLES IN THE TOP OF THE SCOREBOARD AND IN THE ANGLE ARE NOT USED IN THIS INSTALLATION.

SUSPENSION LIFT EYE KIT IS DAKTRONICS PART NO. 0A-1237-0016.

IMPORTANT -
DO NOT ATTACH SUSPENSION HARDWARE TO AD PANEL MOUNTED ON TOP OF SCOREBOARD. SCOREBOARD MUST BE AT THE TOP

30° MAX

FRONT VIEW

SIDE VIEW
TOP OF SCOREBOARD
TYP. BOTH ENDS

03	23 OCT 02	REVERSED ORIENTATION OF NUT PLATE	AVB	
02	01 NOV 01	ADDED NOTES ABOUT NOT SUSPENDING FROM AN AD PANEL.	AVB	
01	27 SEP 01	ADDED KIT PART NUMBER AND NOTE THAT SHACKLE IS NOT PROVIDED.	AVB	
REV.	DATE	DESCRIPTION	BY	APPR.

DAKTRONICS, INC. BROOKINGS, SD 57006			
PROJ:			
TITLE: SUSPENSION LIFT EYE INSTALLATION			
DES. BY: AVB		DRAWN BY: A VANBEMMEL	
		DATE: 09 MAY 01	
REVISION	APPR. BY:	1237-R10A-148644	
	SCALE: 1=4		

12V DC HORN OPTION INSTALLATION PROCEDURE

12V DC HORN
IN BRACKET:

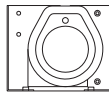

TOP VIEW

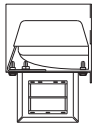

SIDE VIEW

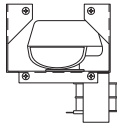

FRONT VIEW

REMOVE THE FOUR SCREWS SECURING THE CLOCK PANEL. DISCONNECT THE PLUGS AT THE BACK OF THE DIGITS, AND UNPLUG THE EXISTING BUZZER TYPE HORN.

REMOVE THE SCREWS THAT ATTACH THE BUZZER HORN TO THE CLOCK PANEL.

MOUNT THE 12V DC HORN TO THE CLOCK PANEL USING THE SCREWS PROVIDED WITH IT. IF MOUNTING HORN IN A UNIVIEW APPLICATION, THE TRANSFORMER WILL HIT THE DIGITS SO NOTE THE FOLLOWING. CUT THE CABLE TIE OFF THE TRANSFORMER HARNESS AND REMOVE TRANSFORMER FROM HORN ASSEMBLY (SAVE HC-1470 SCREWS AS THEY WILL BE REUSED). IN ALTERNATE TRANSFORMER LOCATION MARKED BELOW, DRILL 0.203" (13/64") HOLES @2 IN BACKSHEET FOR TRANSFORMER. USING HC-1470 @2 (SAVED FROM ABOVE) AND HC-1243 @2 (FORWARDED WITH HORN ASSEMBLY), MOUNT TRANSFORMER TO BACKSHEET. MOUNT HORN ASSEMBLY TO CLOCK PANEL AS PREVIOUSLY NOTED.

TAKE THE HORN INTERFACE CARD, WITH HARNESES CONNECTED TO IT, AND USE THE TAPE TO SECURE IT TO THE BACKSHEET. MAKE SURE IT IS AN OPEN SPOT SO IT DOESN'T GET TOUCHED WHEN THE PANEL IS PLACED BACK ON.

RUN THE TWO NEW HARNESES TO THE DRIVER. DISCONNECT EXISTING PLUG IN J18 ON DRIVER. CONNECT NEW ONE. DISCONNECT EXISTING PLUG IN THE J43 POWER JACK ON DRIVER TRAY HARNESS THAT WAS FOR THE OLD HORN, AND PLUG IN THE NEW ONE.

CONNECT THE 2-PIN PLUG FROM THE HORN ASSEMBLY TO J3 ON THE HORN INTERFACE CARD.

PLUG THE DIGIT CABLES INTO THE BACKS OF THE DIGITS AND RE-INSTALL THE CLOCK PANEL.

TEST THE HORN BY OPERATING THE SCOREBOARD AND PRESSING THE HORN BUTTON ON THE CONTROL CONSOLE.

FRONT OF SCOREBOARD, CLOCK AREA:

DAKTRONICS

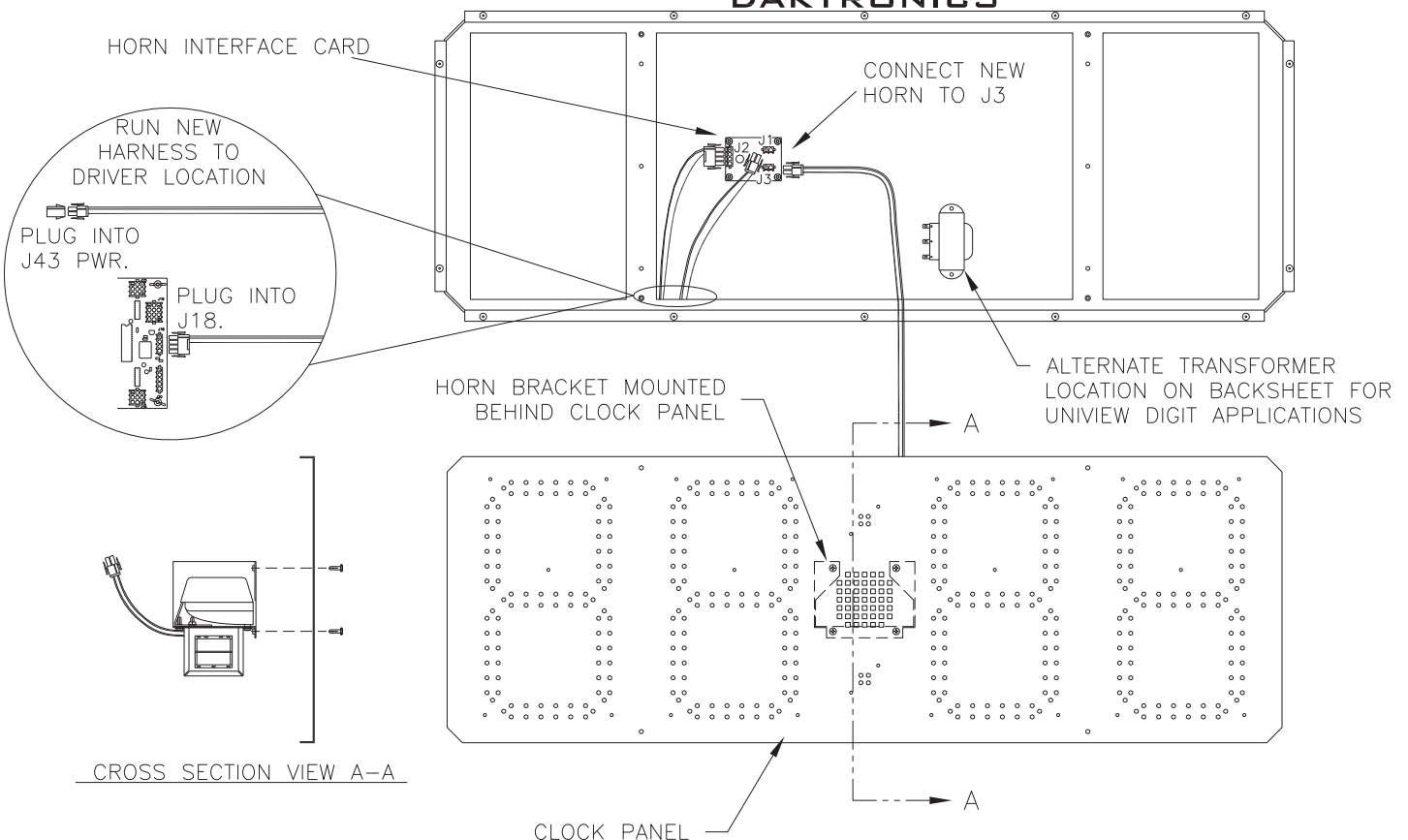

THE CONCEPTS EXPRESSED AND DETAILS SHOWN ON THIS DRAWING ARE CONFIDENTIAL AND PROPRIETARY. DO NOT REPRODUCE BY ANY MEANS, INCLUDING ELECTRONICALLY WITHOUT THE EXPRESSED WRITTEN CONSENT OF DAKTRONICS, INC. COPYRIGHT 2002 DAKTRONICS, INC.			
DAKTRONICS, INC. BROOKINGS, SD 57006			
PROJ: TUFF SPORT™ INDOOR SCOREBOARDS			
TITLE: 12V DC HORN OPTION INSTALLATION			
DES. BY: AVB		DRAWN BY: A VANBEMMEL	
		DATE: 16 MAY 01	
REVISION	APPR. BY:	1237-R10A-148960	
03	SCALE: 1=10		

REV.	DATE	DESCRIPTION	BY	APPR.
03	07 JAN 10	UPDATED INSTALL DRAWING WITH HORN INTERFACE CARD DETAILS AND STEPS.	MWM	
02	20 JUN 06	UPDATED COLON AND HORN LAYOUT. REPLACED UNIVIEW DIGITS WITH PANAVIEW TO SHOW HORN MOUNTING. ADDED UNIVIEW HORN MTG NOTES. CHANGED DIGITS TO UNIVIEW.	JLF	CW
01	20 JUN 02		ALG	

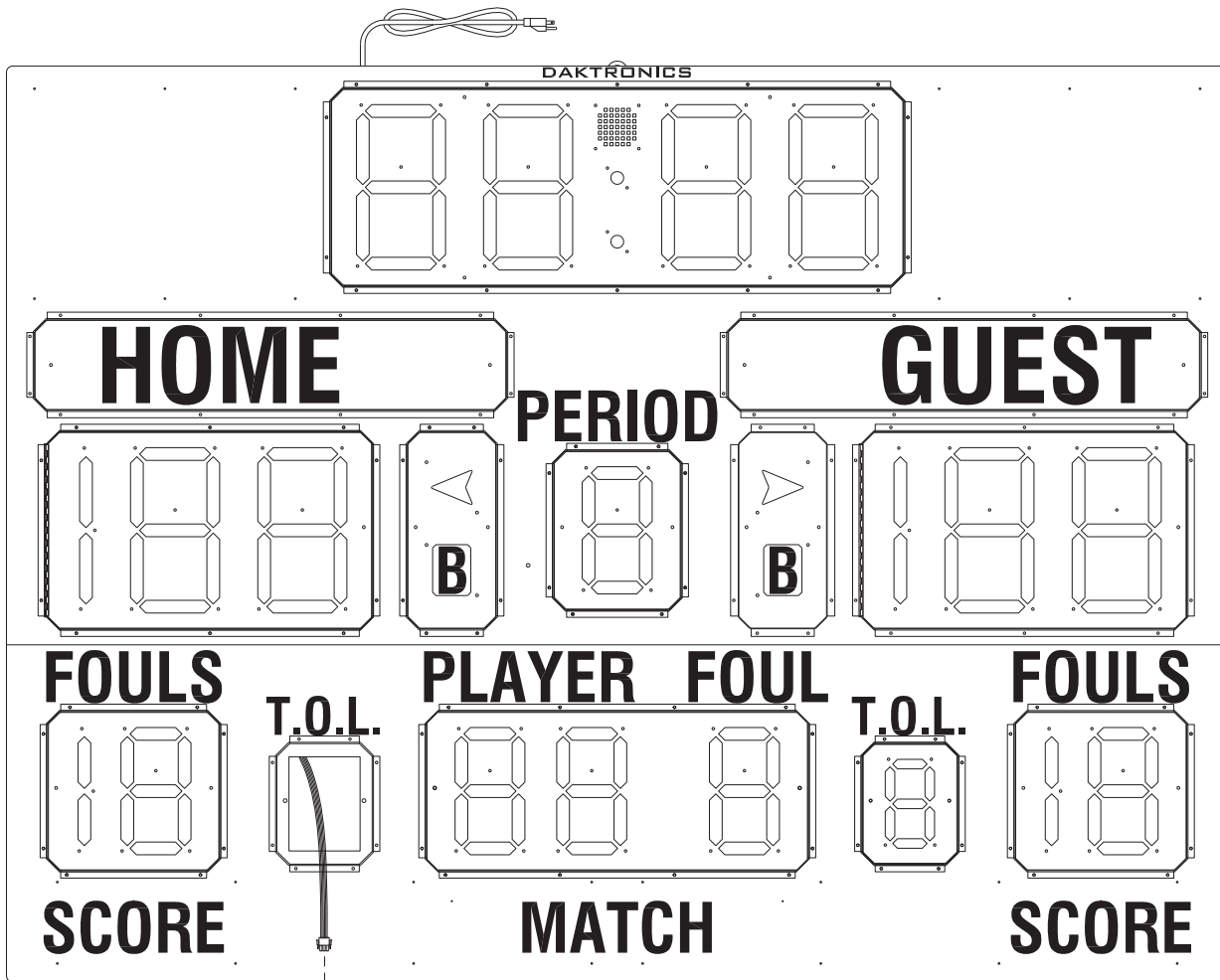

9-PIN JACK LOCATION ON BACK OF DIGIT

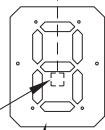

T.O.L. DIGIT PANEL

1. REMOVE THE TWO BLANK PANELS CURRENTLY INSTALLED IN PLACE OF THE T.O.L. DIGITS.

2. LOCATE THE CABLES WITH 9-PIN PLUGS BEHIND THE BLANK PANELS. CONNECT THE PLUGS TO THE MATING JACK ON THE BACK OF EACH DIGIT.

3. INSTALL THE DIGITS IN THE OPENINGS AND SECURE WITH THE SCREWS THAT FORMERLY HELD THE BLANK PANELS.

4. APPLY THE "T.O.L." CAPTIONS ABOVE THE DIGITS.

NOTES:

THE SCOREBOARD IS SHOWN WITH UNIVIEW™ DIGIT TECHNOLOGY. SEE DRAWING A-158550 FOR MORE DETAILS.

THE CONCEPTS EXPRESSED AND DETAILS SHOWN ON THIS DRAWING ARE CONFIDENTIAL AND PROPRIETARY. DO NOT REPRODUCE BY ANY MEANS, INCLUDING ELECTRONICALLY WITHOUT THE EXPRESSED WRITTEN CONSENT OF DAKTRONICS, INC. COPYRIGHT 2002 DAKTRONICS, INC.

DAKTRONICS, INC. BROOKINGS, SD 57006

PROJ: TUFF SPORT™ SCOREBOARDS

TITLE: T.O.L. OPTION INSTALLATION

DES. BY: AVB

DRAWN BY: A VANBEMMEL

DATE: 17 MAY 01

REVISION

APPR. BY:

SCALE: 1=20

1237-R10A-149030

01	20 JUN 02	CHANGED DIGITS TO UNIVIEW.	ALG	
REV.	DATE	DESCRIPTION	BY	APPR.

REV.	01	20 MAY 02	REPLACED THE 6-32 X 3/8" FLAT HEAD SCREW WITH 8-32 X 5/8" STUD.	BY	JUS	APPR.
DESCRIPTION						

PROJ.: TUFF SPORT SCOREBOARDS		DAKTRONICS, INC. BROOKINGS, SD 57006	
TITLE: CHANGEABLE TEAM NAME CAPTION INSTALLATION			
DES. BY: AVB	APPR. BY:	DRAWN BY: A VANBEMMEL	DATE: 06 JUN 01
REVISION	01	SCALE: 1=8	1237-E10A-150021

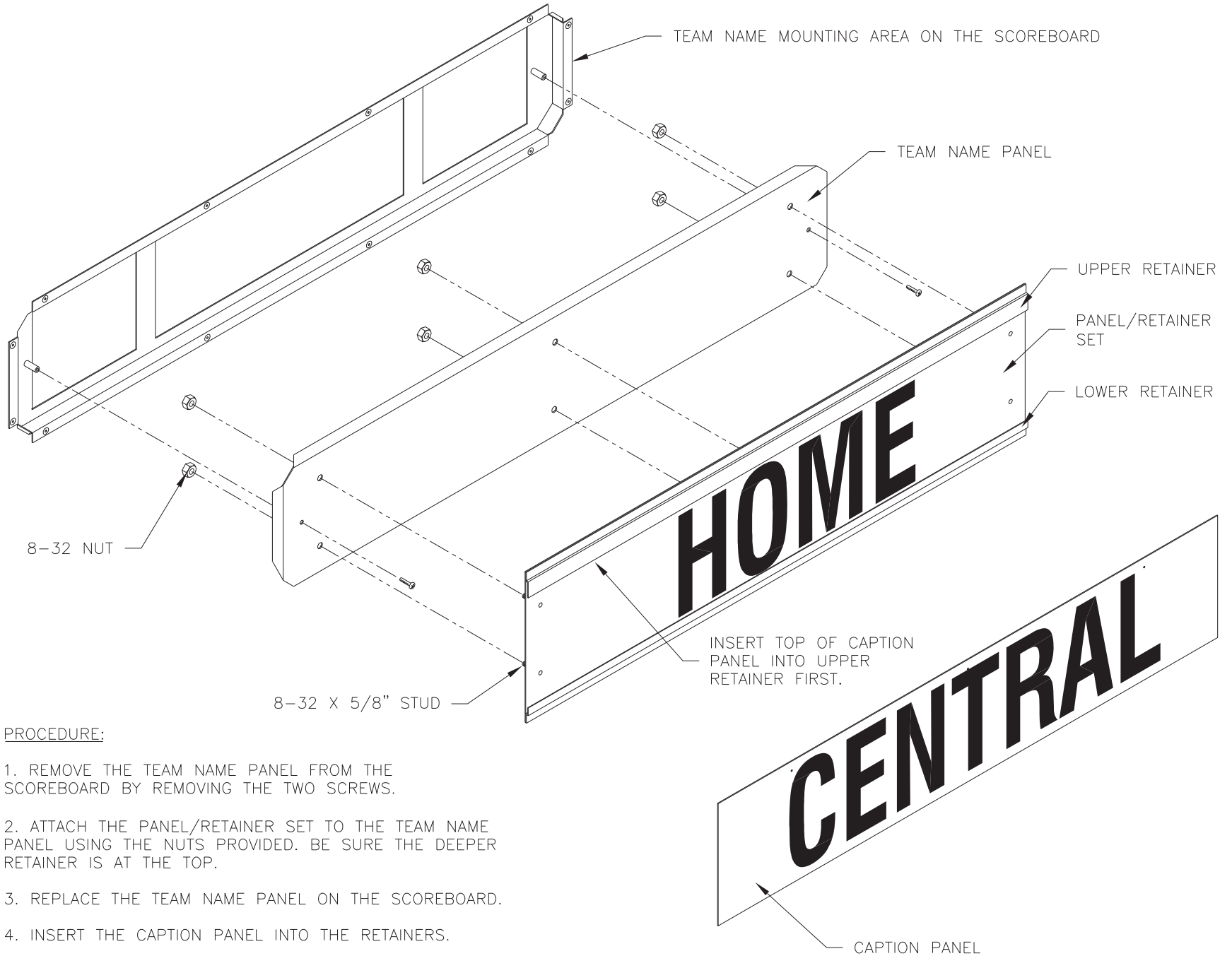

PROCEDURE:

1. REMOVE THE TEAM NAME PANEL FROM THE SCOREBOARD BY REMOVING THE TWO SCREWS.
2. ATTACH THE PANEL/RETAINER SET TO THE TEAM NAME PANEL USING THE NUTS PROVIDED. BE SURE THE DEEPER RETAINER IS AT THE TOP.
3. REPLACE THE TEAM NAME PANEL ON THE SCOREBOARD.
4. INSERT THE CAPTION PANEL INTO THE RETAINERS.

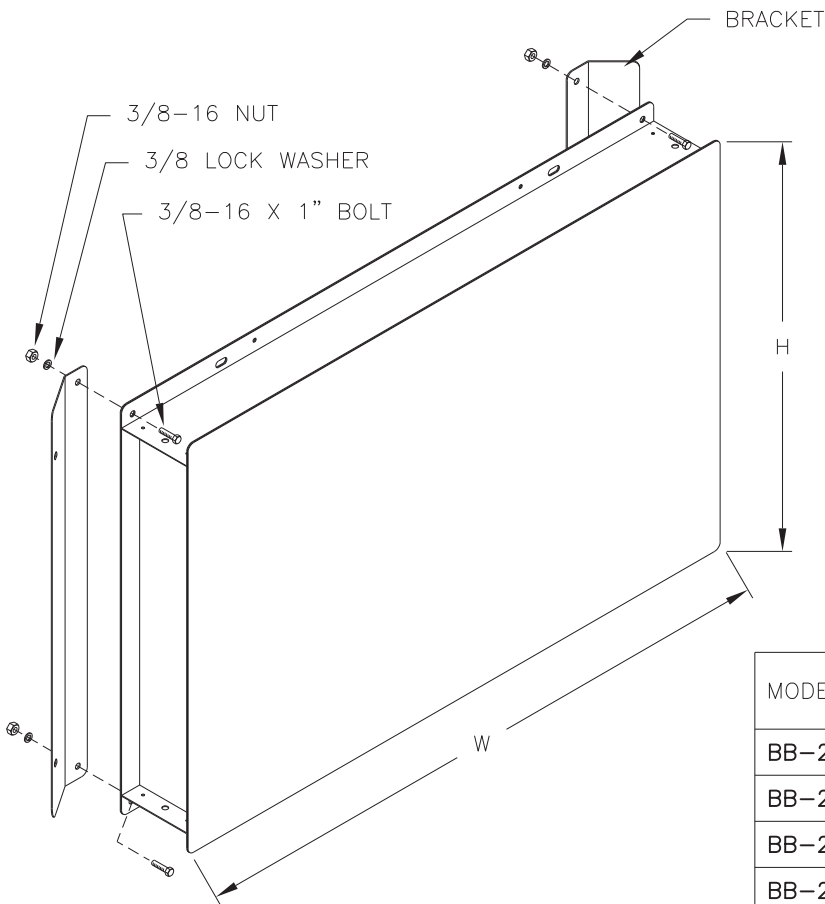

ATTACH THE BRACKETS TO THE BACK OF THE SCOREBOARD USING THE 3/8" HARDWARE PROVIDED.

DRILL HOLES IN THE WALL AT THE APPROPRIATE DISTANCE FROM THE CORNER (DIMENSION D) FOR THE WALL ANCHORS.

MOUNT THE BRACKETS TO THE WALL USING WALL ANCHORS SUITABLE TO THE WALL MATERIALS IN THE FACILITY.

MODEL NO.	HEIGHT DIM. H	WIDTH DIM. W	DISTANCE DIM D
BB-2101/3101	4'-0"	8'-0"	5'-11 1/4"
BB-2103/3103	6'-0"	8'-0"	5'-11 1/4"
BB-2105/3105	4'-0"	10'-0"	7'-4 1/16"
BB-2107/3107	6'-0"	10'-0"	7'-4 1/16"
BB-2142/3142	3'-0"	6'-6"	4'-10 3/8"
BB-2121/3121	2'-6"	10'-0"	7'-4 1/16"

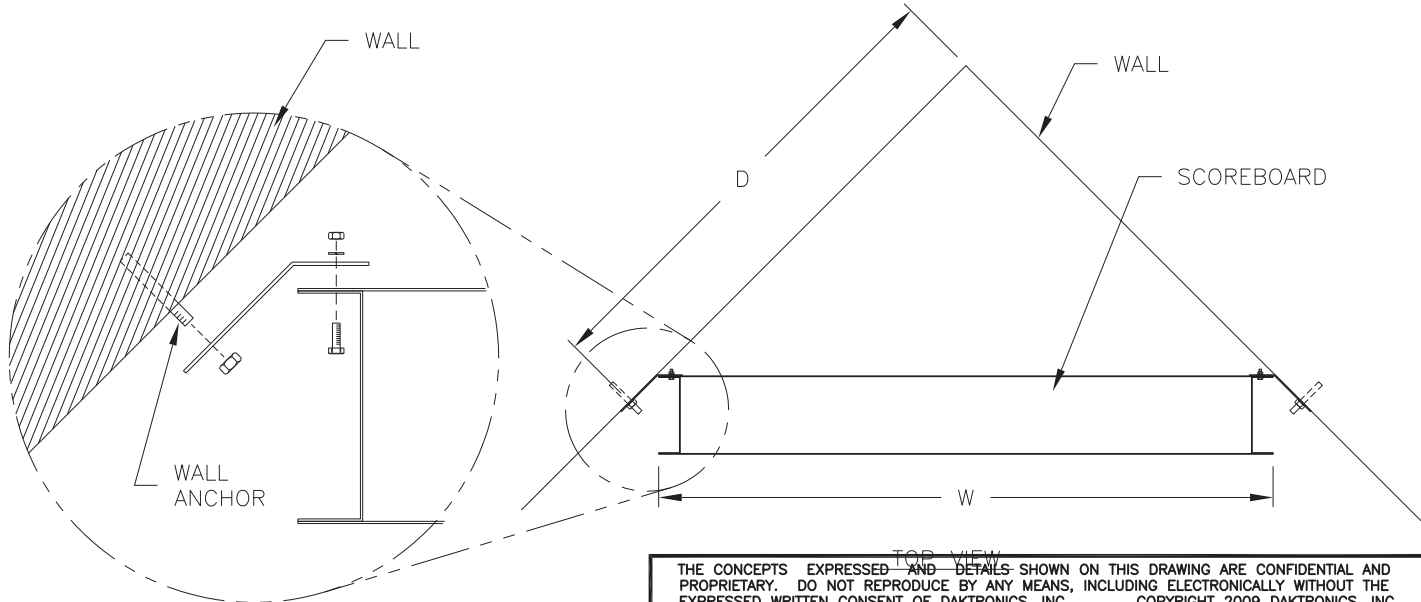

THE CONCEPTS EXPRESSED AND DETAILS SHOWN ON THIS DRAWING ARE CONFIDENTIAL AND PROPRIETARY. DO NOT REPRODUCE BY ANY MEANS, INCLUDING ELECTRONICALLY WITHOUT THE EXPRESSED WRITTEN CONSENT OF DAKTRONICS, INC. COPYRIGHT 2009 DAKTRONICS, INC.

DAKTRONICS, INC. BROOKINGS, SD 57006

PROJ: TUFF SPORT SCOREBOARDS

TITLE: CORNER MOUNTING

DES. BY: AVB DRAWN BY: A VANBEMMEL DATE: 22 JUN 01

REVISION 01 APPR. BY: SCALE: 1=15

1237-R10A-150831

REV.	DATE	DESCRIPTION	BY	APPR.
01	28JAN10	ADD ALL 3xxx MODELS NUMBERS AND ADD BB-2142/3142 AND BB-2121/3131 AND THEIR RESPECTIVE REQUIRED DIMENSIONS	LMIX	

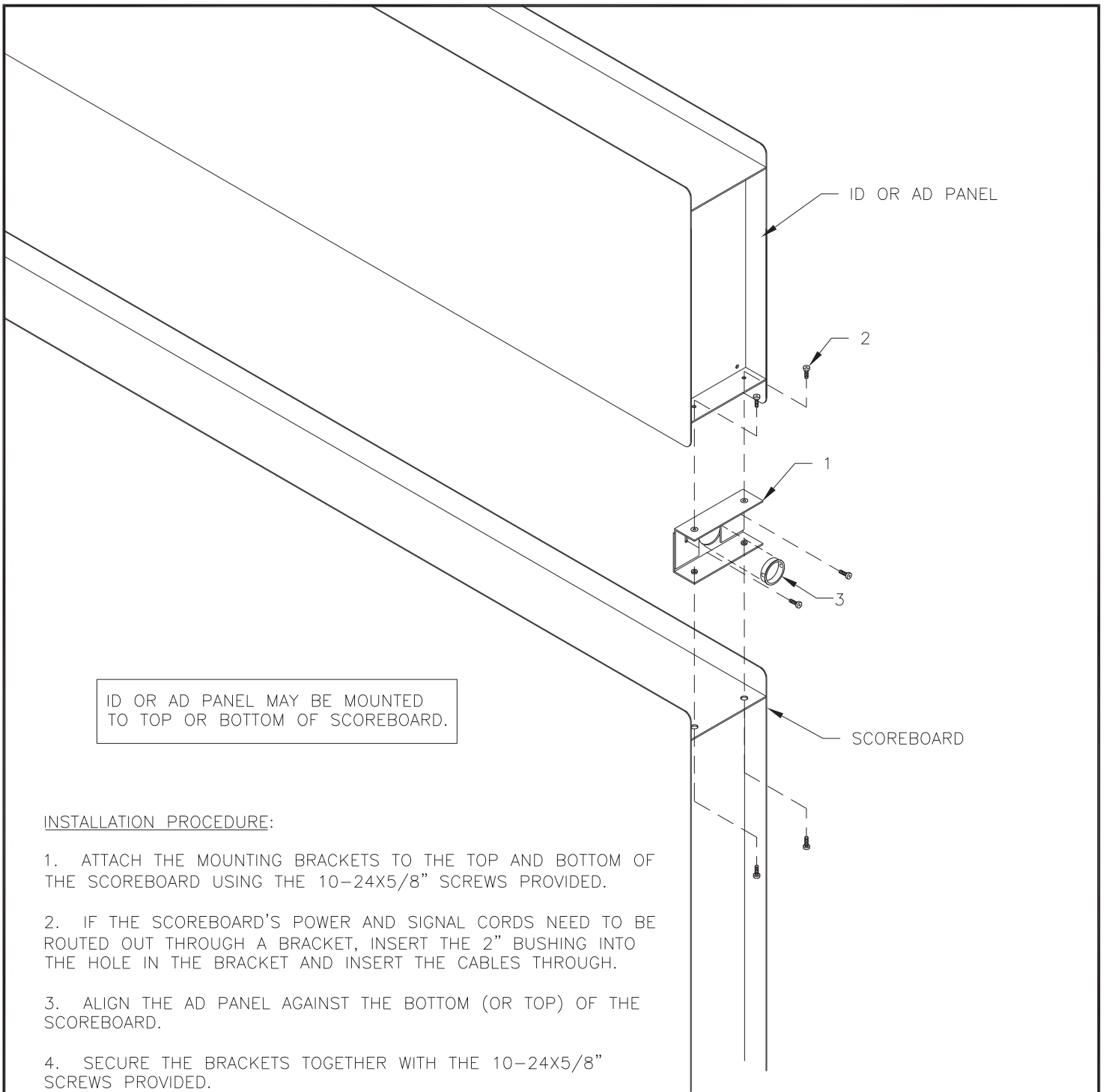

ID OR AD PANEL MAY BE MOUNTED TO TOP OR BOTTOM OF SCOREBOARD.

INSTALLATION PROCEDURE:

1. ATTACH THE MOUNTING BRACKETS TO THE TOP AND BOTTOM OF THE SCOREBOARD USING THE 10-24X5/8" SCREWS PROVIDED.
2. IF THE SCOREBOARD'S POWER AND SIGNAL CORDS NEED TO BE ROUTED OUT THROUGH A BRACKET, INSERT THE 2" BUSHING INTO THE HOLE IN THE BRACKET AND INSERT THE CABLES THROUGH.
3. ALIGN THE AD PANEL AGAINST THE BOTTOM (OR TOP) OF THE SCOREBOARD.
4. SECURE THE BRACKETS TOGETHER WITH THE 10-24X5/8" SCREWS PROVIDED.

DESCRIPTION	PART NUMBER	QTY
1. MOUNTING BRACKETS	0S-1237-0058	2
2. SCREW, 10-24x5/8	HC-1022	12
3. BUSHING, 2.0 Ø	HE-1051	2

REV.	DATE	DESCRIPTION	BY	APPR.
02	18 JUL 06	REPLACED 0M-150458 BRKT WITH 0M-278266-A AND 0M-278266-B BRKTS	KAS	
01	20 JAN 03	REPLACED HC-1470 WITH HC-1022 RIVETS	RJC	

DAKTRONICS, INC. BROOKINGS, SD 57006	
PROJ: TUFF SPORT SCOREBOARDS	
TITLE: ID OR AD PANEL MOUNTING TO SCOREBOARD	
DES. BY: BPETERSON	DRAWN BY: JJSYRSTAD
DATE: 20 SEP 01	
REVISION	APPR. BY:
02	NONE
1237-R04A-156134	

TNMC INSTALLATION INSTRUCTIONS

1. REMOVE THE HOME/GUEST FACE PANELS FROM THE DISPLAY. REFERENCE FIGURE 1
2. MOUNT THE POWER SUPPLY ASSEMBLY TO THE BACK OF THE TNMC PAN WITH HC-1470 SCREWS. THE WIRES ARE ALREADY CONNECTED TO THE POWER SUPPLY. REFERENCE FIGURE 2
3. ROUTE THE 5V DC WIRES FROM THE POWER SUPPLY THROUGH THE OPENING TO THE TNMC LOCATIONS. ROUTE THE 120V POWER INTERCONNECT CABLE BETWEEN THE POWER SUPPLIES AND CONNECT. ROUTE THE POWER INPUT CABLE FROM THE HOME TNMC'S POWER SUPPLY TO THE 2-PIN PLUG AT THE DRIVER. REFERENCE FIGURE 3
4. INSTALL THE SIGNAL HARNESS. ROUTE THE SIGNAL HARNESS FROM J23 AT THE DRIVER TO THE TNMC LOCATIONS. REFERENCE FIGURE 3
5. CONNECT THE POWER AND SIGNAL TO THE TNMCS. REFERENCE FIGURE 3
6. DRIVER IS PRE-SET TO ADDRESS 221. ANY OTHER ADDRESS VALUES NEED TO BE SET USING S2 DIP SWITCH PACKAGE. TEST DISPLAY USING ALLSPORT AND BASKETBALL. PROGRAM A NAME INTO BOTH HOME AND GUEST USING MENU FUNCTIONS PER STANDARD TESTING PROCEDURES.

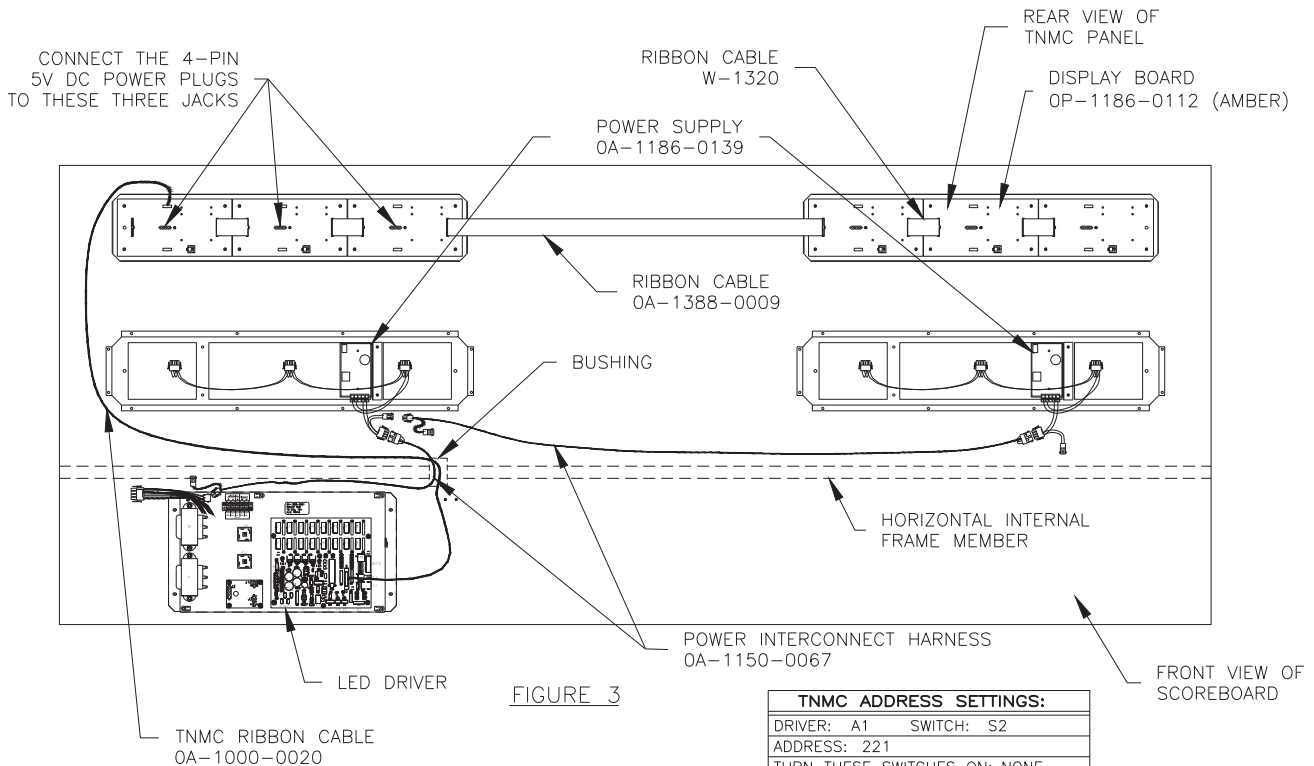
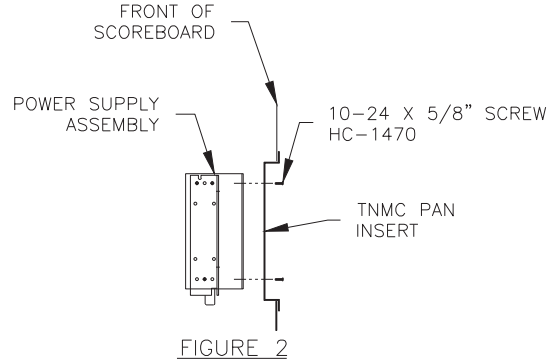
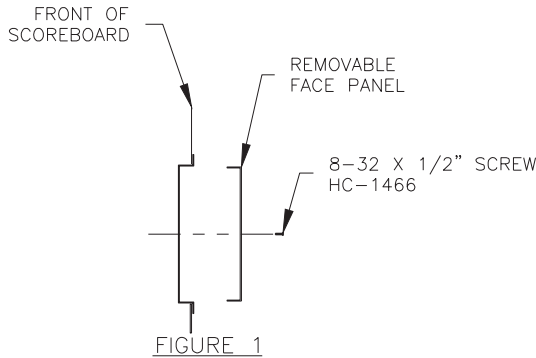

TNMC ADDRESS SETTINGS:

DRIVER: A1 SWITCH: S2
 ADDRESS: 221
 TURN THESE SWITCHES ON: NONE

OFF ON

SIDE VIEW

1 2 3 4 5 6 7 8

TUFF SPORT™ & COLORSMART™ ARE TRADEMARKS OF DAKTRONICS

 DAKTRONICS, INC. BROOKINGS, SD 57006 DO NOT SCALE DRAWING		THE CONCEPTS EXPRESSED AND DETAILS SHOWN ON THIS DRAWING ARE CONFIDENTIAL AND PROPRIETARY. DO NOT REPRODUCE BY ANY MEANS WITHOUT THE EXPRESSED WRITTEN CONSENT OF DAKTRONICS, INC. COPYRIGHT 2010 DAKTRONICS, INC.	
PROJ: TUFFSPORT COLORSMART SCOREBOARDS TITLE: INSTALLATION- MCAST- 6" AMBER 8X48 TNMC			
DESIGN:		DRAWN: KBRICKER	
SCALE: 1=20		DATE: 08 FEB 07	
SHEET	REV	JOB NO:	FUNC-TYPE-SIZE
	03	P1389	E-10-A
			296610

REV 03	DATE: 03 DEC 10	RENAMED J32 TO J23	BY: JJD
REV 02	DATE: 01 SEP 09	UPDATE TNMC INFORMATION AND ADDRESS SETTINGS. AND PER ECO 60218, CHANGED OA-1000-0022 TO -0020	BY: MWM
REV 01	DATE: 09 JAN 08	REPLACED OP-1186-0205 WITH OP-1186-0112.	BY: KJB

PROGRAMMABLE CAPTION INSTALLATION INSTRUCTIONS

1. REMOVE THE PLYR/FLS/PTS FACE PANELS FROM THE DISPLAY.
REFERENCE FIGURE 1
2. MOUNT THE POWER SUPPLY ASSEMBLY TO THE BACK OF THE CAPTION PAN WITH HC-1470 SCREWS. THE WIRES ARE ALREADY CONNECTED TO THE POWER SUPPLY. REFERENCE FIGURE 2
3. ROUTE THE 5V DC WIRES FROM THE POWER SUPPLY THROUGH THE OPENING TO THE MODULE LOCATIONS. ROUTE THE POWER INPUT CABLE FROM THE PROGRAMMABLE CAPTIONS POWER SUPPLY (0A-1186-0139) TO THE 2-PIN PLUG AT THE DRIVER. REFERENCE FIGURE 3
4. INSTALL THE SIGNAL CABLE. ROUTE THE SIGNAL RIBBON CABLE FROM J23 AT THE DRIVER TO THE PROGRAMMABLE CAPTION LOCATIONS. REFERENCE FIGURE 3
5. CONNECT THE POWER AND SIGNAL TO THE PROGRAMMABLE CAPTIONS. REFERENCE FIGURE 3
6. SET TNMC ADDRESS SETTING ON DRIVER USING DIP SWITCH PACKAGE S2. TURN ON THE 2ND SWITCH AND THE 5TH SWITCH. ALL OTHERS SHOULD BE TURNED 'OFF'. THIS WILL PROVIDE ADDRESS 223 AND PRE-MADE CAPTION LETTERS ON THE MODULES.
7. TEST DISPLAY USING ALLSPORT AND BASKETBALL. MAKE SURE LETTERS APPEAR ON THE PROGRAMMABLE CAPTION AUTOMATICALLY.

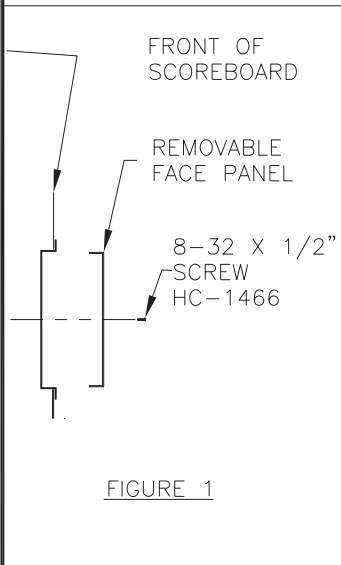

FIGURE 1

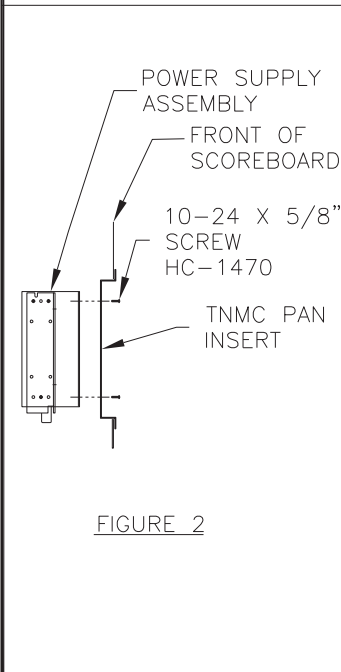
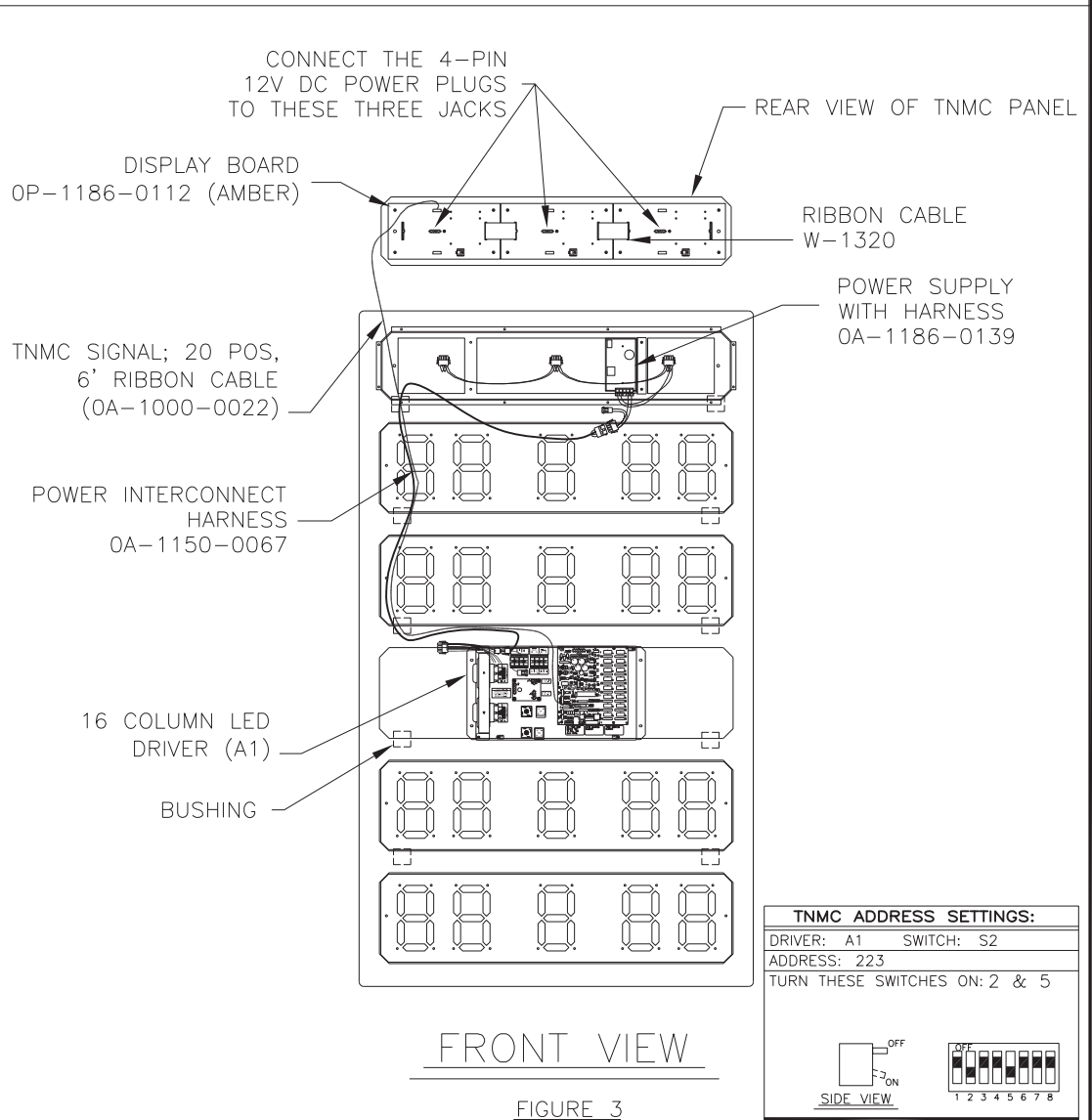

FIGURE 2



FRONT VIEW

FIGURE 3

TUFF SPORT™, & COLORSMART™ ARE TRADEMARKS OF DAKTRONICS

THE CONCEPTS EXPRESSED AND DETAILS SHOWN ON THIS DRAWING ARE CONFIDENTIAL AND PROPRIETARY. DO NOT REPRODUCE BY ANY MEANS, INCLUDING ELECTRONICALLY WITHOUT THE EXPRESSED WRITTEN CONSENT OF DAKTRONICS, INC. COPYRIGHT 2008 DAKTRONICS, INC.

DAKTRONICS, INC. BROOKINGS, SD 57006

PROJ:	TUFFSPORT™	COLORSMART™	SCOREBOARDS
TITLE:	INSTALLATION: PROGRAMMABLE CAPTION- 8X48-6"- MCAST		
DES. BY:	DRAWN BY:	DATE: 31 OCT 07	
REVISION	APPR. BY:	1389-E10A-324099	
03	SCALE: 1=20		

03	01 SEP 09	ADDED MORE DETAILS TO SET THE ADDRESS SWITCH FOR THE PROGRAMMABLE CAPTIONS	MWM	
02	27 OCT 08	CHANGED ADDRESS SWITCH DETAIL	KZB	
01	09 JAN 08	REPLACED 0P-1186-0205 WITH 0P-1186-0112.	KJB	
REV.	DATE	DESCRIPTION	BY	APPR.

Appendix D: Schematic Drawings

<i>Drawing Title</i>	<i>Drawing Number</i>
Schematic; Dual 1/4" Phone J-box w/ Shunt Jack.....	A-125316
Schematic: BB-2114 / BB-3114- 120VAC (prior to Nov 2011)	B-202715
Schematic; 2-Driver, Color Smart.....	B-283553
Schematic; 3-Driver, Color Smart.....	B-283857
Schematic- MCAST Game/Shot Clock (prior to Dec 2012).....	B-285100
Schematic: Multicast TNMC 3/4" (.75).....	A-296394
Schematic- MCAST- 16 col Driver Assy.....	A-306287
Schematic: BB-2114 / BB-3114- 120VAC	B-1045157
Schematic - MCAST Game/Shot Clock.....	B-1122009

Model	Drawing Title	Drawing Number
BB-3101	Schematic- MCAST- 16 col Driver Assy	A-306287
BB-3103	Schematic- MCAST- 16 col Driver Assy	A-306287
BB-3105	Schematic- MCAST- 16 col Driver Assy	A-306287
BB-3107	Schematic- MCAST- 16 col Driver Assy	A-306287
BB-3114	Schematic: BB-2114 / BB-3114- 120VAC	B-1045157
BB-3115	Schematic - MCAST Game/Shot Clock	B-1122009
BB-3121	Schematic- MCAST- 16 col Driver Assy	A-306287
BB-3123	Schematic; 2-Driver, Color Smart	B-283553
BB-3125	Schematic- MCAST- 16 col Driver Assy	A-306287
BB-3142	Schematic- MCAST- 16 col Driver Assy	A-306287
SD-3101	Schematic; 2-Driver, Color Smart	B-283553
SD-3102	Schematic; 2-Driver, Color Smart	B-283553
SD-3103	Schematic; 3-Driver, Color Smart	B-283857

The following schematics are for shot clocks built prior to November 2011.

Model	Drawing Title	Drawing Number
BB-3114	Schematic: BB-2114 / BB-3114- 120VAC	B-202715

The following schematics are for shot clocks built prior to December 2012.

Model	Drawing Title	Drawing Number
BB-3115	Schematic- MCAST Game/Shot Clock	B-285100

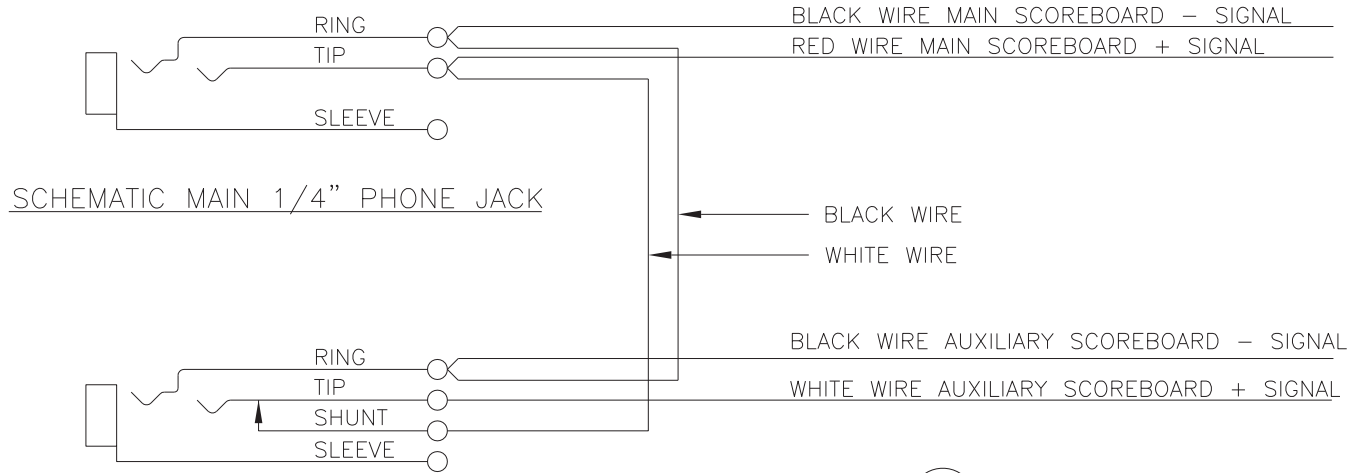

SCHEMATIC MAIN 1/4" PHONE JACK

SCHEMATIC AUXILIARY 1/4" PHONE JACK



0A-1196-0013

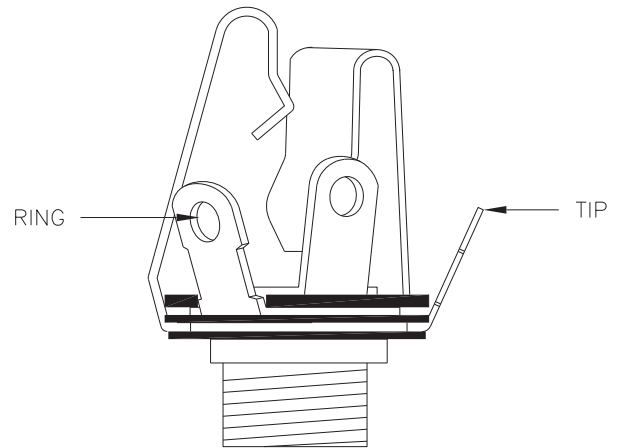

MAIN
 PHONE JACK
 J-1003

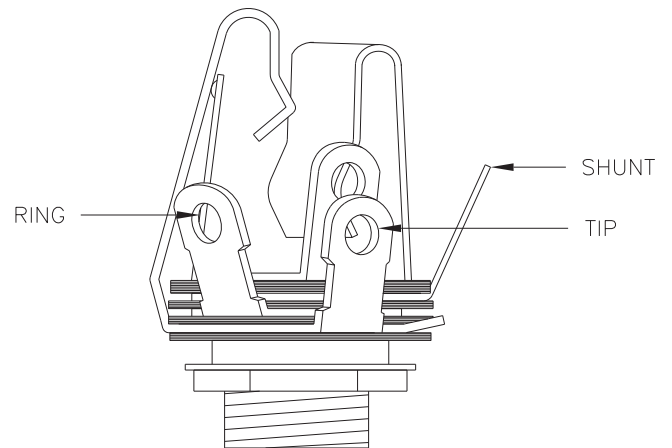

AUXILIARY
 PHONE JACK
 J-1131

DAKTRONICS, INC. BROOKINGS, SD 57006			
PROJ:			
TITLE: SCHEMATIC; DUAL 1/4" PHONE J-BOX W/SHUNT JACK			
DES. BY: E BRAVEK		DRAWN BY: E BRAVEK	
		DATE: 15 DEC 99	
REVISION	APPR. BY:	1196-R03A-125316	
00	SCALE: NONE		

REV.	DATE	DESCRIPTION	BY	APPR.

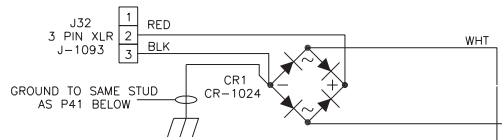

OA-1230-0133
RELAY BOARD HARNESS

OA-1230-0130
SWITCHED OUTLET HARNESS

OA-1230-0128
3' SIGNAL HARN.

J43
WHT
BLK

J45
RADIO
PWR/SIG
CONNECT

P41
OA-1152-0653
120V AC

OA-1150-0070
PWR HARNESS, 2'

OA-1230-0102
1 TX S/C HARNESS

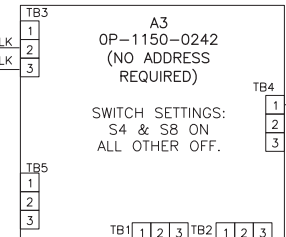

SWITCH SETTINGS:
S4 & S8 ON
ALL OTHER OFF.

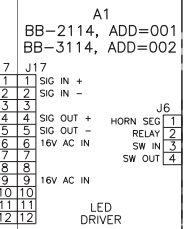

THIS PLUG IS ASSEMBLED AND LABELED
"P7", RELABEL THIS PLUG "P3".

BLK (COMMON)
PNK (GM HORN)
BLU (SHT HORN)
VIO (GM CLK STOP)
GRY (GM CLK=0)

OA-1230-0132
S/C HORN HARNESS

J-19 ADDRESS PLUG

		PIN 12	PIN 11	PIN 9	PIN 8	PIN 6	PIN 5	PIN 3	PIN 2
BB-2114	01	0	0	0	0	0	0	0	1
BB-3114	02	0	0	0	0	0	0	1	0

J42
J-1041
SWITCHABLE
120VAC

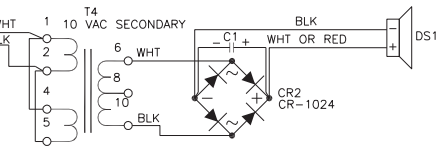

06	02 MAY 08	CHANGE HORN CARD FROM OP-1150-0246 TO OP-1192-0399	MWM
05	18 FEB 08	ADDED GROUND WIRE TO CR1.	AMG
04	18 JAN 07	ADDED WHT OR RED OPTION LABEL TO DS1 PER ECO 53109	JWC
04	18 JAN 07	ADDED WHT OR RED OPTION LABEL TO DS1 PER ECO 53109	JWC
03	09 NOV 06	UPDATED TITLE TO INCLUDE MODEL BB-3114	SAL
02	17 MAR 06	CORRECT RELABELING NOTES PER ECO #49711	ATP
01	04JAN05	ADDED RELABELING NOTES PER ECO 042547, 042508, AND 042548	MCOPL

THE CONCEPTS EXPRESSED AND DETAILS SHOWN ON THIS DRAWING ARE CONFIDENTIAL AND PROPRIETARY. DO NOT REPRODUCE BY ANY MEANS, INCLUDING ELECTRONICALLY WITHOUT THE EXPRESSED WRITTEN CONSENT OF DAKTRONICS, INC. COPYRIGHT 2004 DAKTRONICS, INC.

DAKTRONICS, INC. BROOKINGS, SD 57006

PROJ: TUFF SPORT SCOREBOARDS

TITLE: SCHEMATIC: BB-2114 / BB-3114- 120VAC

DES. BY: CBRECZI DRAWN BY: CBRECZI DATE: 26 MAY 04

REV.	DATE	DESCRIPTION	BY	APPR.
07	06 JAN 10	REMOVED DETAILS OF OBSOLETE CONNECTION BETWEEN A4 AND A1. ADDED NEW DETAILS FOR CONNECTION BETWEEN A4 AND A3.	EJS	

REVISION	SCALE: 1=1	1237-R03B-202715
----------	------------	------------------

120V 3-DRIVER ASSY COLOR SMART

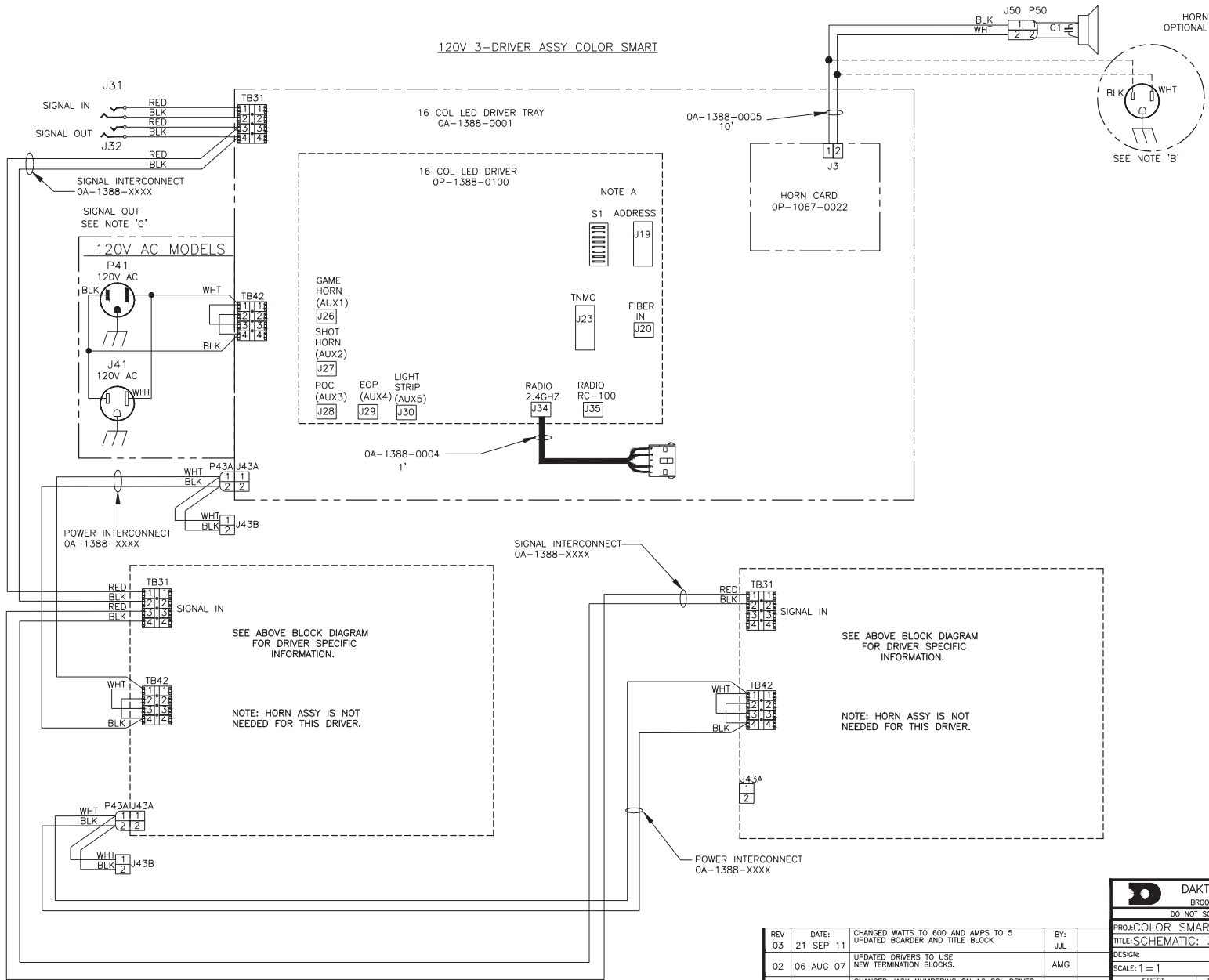

NOTE A:
8-POS DIP SWITCH.
SET THE ADDRESS PER MODEL SPECS.
NOTE 'B':
J-1041 @1 & E-1047 @2, USED FOR
EXTERNAL HORN APPLICATIONS. NOT AVAILABLE
ON SOME MODELS.
NOTE 'C':
NOT USED IN SOME MODELS.

120V AC MODELS

SPECIFICATION LABEL DATA	
MODEL NO:	(PER ORDER)
VOLTS:	120 VAC, SINGLE PHASE
WATTS:	600
AMPS:	5

SEE ABOVE BLOCK DIAGRAM
FOR DRIVER SPECIFIC
INFORMATION.

NOTE: HORN ASSY IS NOT
NEEDED FOR THIS DRIVER.

SEE ABOVE BLOCK DIAGRAM
FOR DRIVER SPECIFIC
INFORMATION.

NOTE: HORN ASSY IS NOT
NEEDED FOR THIS DRIVER.

DAKTRONICS, INC.
BROOKINGS, SD 57006
DO NOT SCALE DRAWING

PROJ: COLOR SMART		DATE: 28 AUG 06	
TITLE: SCHEMATIC: 3-DRIVER - COLOR SMART		DRAWN: SCOLGRO	
SCALE: 1 = 1	REV	JOB NO:	FLUNC-TYPE-SIZE
SHEET	03	P1388	R-03-B

REV	DATE	DESCRIPTION	BY
03	21 SEP 11	CHANGED WATTS TO 600 AND AMPS TO 5 UPDATED BOARDER AND TITLE BLOCK	JJL
02	06 AUG 07	UPDATED DRIVERS TO USE NEW TERMINATION BLOCKS.	AMG
01	07 FEB 07	CHANGED JACK NUMBERING ON 16 COL DRIVER	JWC

283857

REV.	DATE	DESCRIPTION	BY	APPR.
04	16 SEP 09	CHANGED 0A-1000-0022 TO 0A-1000-0020 PER ECO 80218	MMM	
03	01 SEP 09	UPDATED DETAILS TO SHOW TNMC OR CAPTION DETAILS BETTER	MMM	
02	29 DEC 08	REVISED PIN OUT OF P42, MOVED PIN 2 TO PIN 4 PER ECO 69496.	DKD	
01	08 FEB 07	ADDED J NUMBERS TO DRAWING CHANGED SIZE OF FINAL TNMC MOD TO MATCH	ATL	

PROJ:	DAKTRONICS, INC. BROOKINGS, SD 57006
TITLE:	SCHEMATIC: MULTICAST TNMC 3/4" (.75)
DES. BY:	MILLER
APPR. BY:	ALCHT
DATE:	06 FEB 07
REVISION:	04
SCALE:	NONE
1388-R03A-296394	

THE CONCEPTS EXPRESSED AND DETAILS SHOWN ON THIS DRAWING ARE CONFIDENTIAL AND PROPRIETARY. DO NOT REPRODUCE BY ANY MEANS, INCLUDING ELECTRONICALLY WITHOUT THE EXPRESSED WRITTEN CONSENT OF DAKTRONICS, INC. COPYRIGHT 2007 DAKTRONICS, INC.

8x16 - 1 MODULE
 8x32 - 2 MODULES
 8x48 - 3 MODULES
 8x64 - 4 MODULES **SHOWN BELOW**

REAR VIEW
3/4" LED DC TNMC'S

CONNECT USING DIRECTIONS IN
 BOTTOM LEFT CORNER

0A-1388-0009
 6' TNMC INTERCONNECT
 ONLY USED WHEN 2 TNMCS ARE IN SAME SECTION

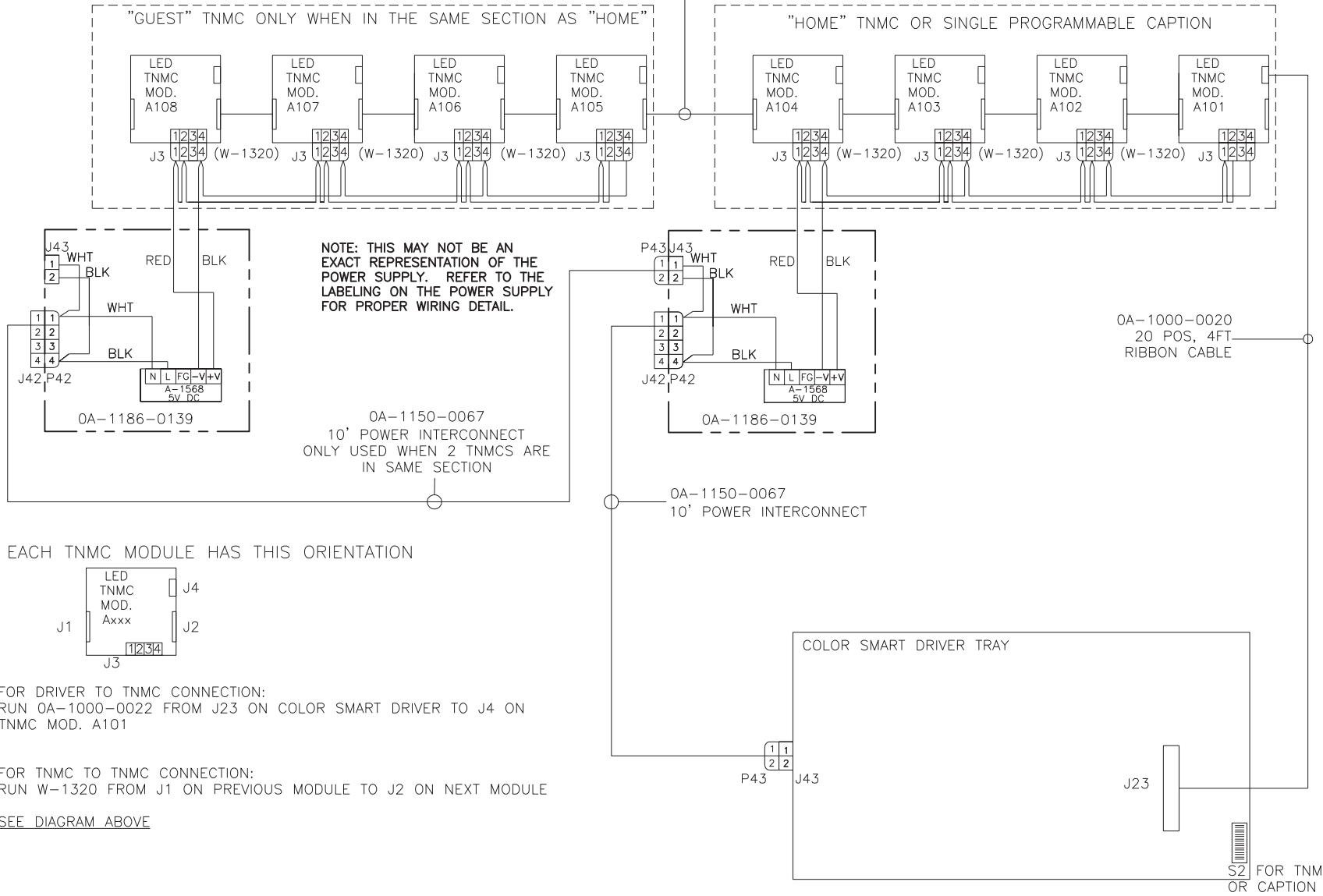

EACH TNMC MODULE HAS THIS ORIENTATION

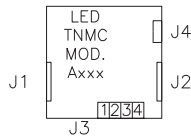

FOR DRIVER TO TNMC CONNECTION:
 RUN 0A-1000-0022 FROM J23 ON COLOR SMART DRIVER TO J4 ON TNMC MOD. A101

FOR TNMC TO TNMC CONNECTION:
 RUN W-1320 FROM J1 ON PREVIOUS MODULE TO J2 ON NEXT MODULE

SEE DIAGRAM ABOVE

REV	DATE:	ADDED RADIO HARNESS DETAILS	BY:
04	01 OCT 12		KZB
REV	DATE:	REMOVED SPECIFICATIONS FOR 230VAC MODELS	BY:
03	21 SEP 11		JLL
02	10 OCT 08	UPDATED HORN CAB	DKD
01	22 AUG 07	ADDED J43, OUTPUT FOR ADDITIONAL DRIVERS.	AMG

120VAC MODELS

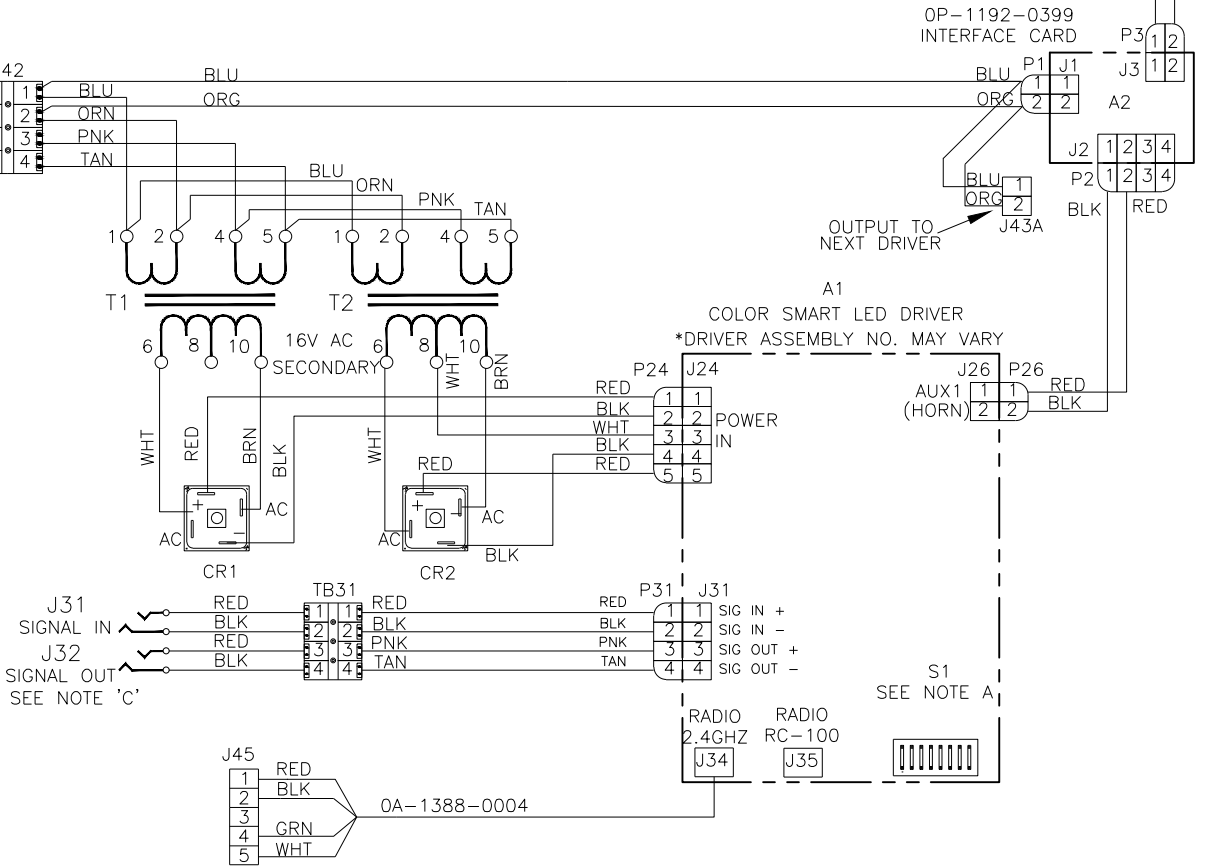
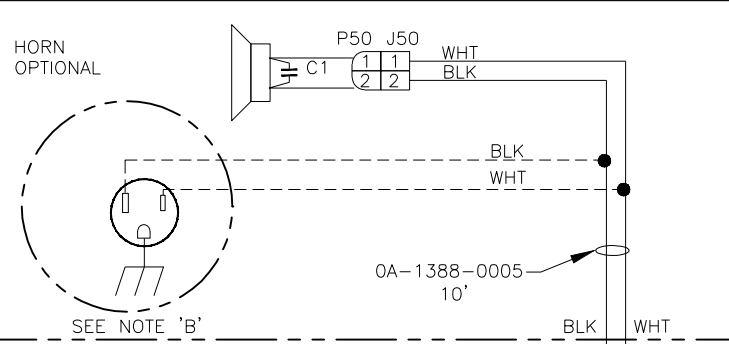
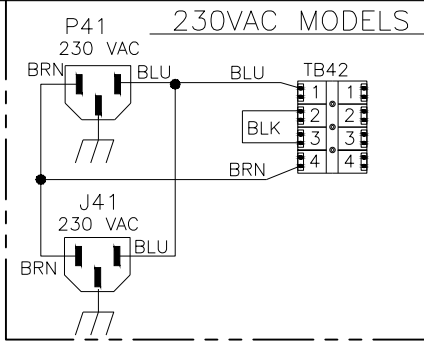
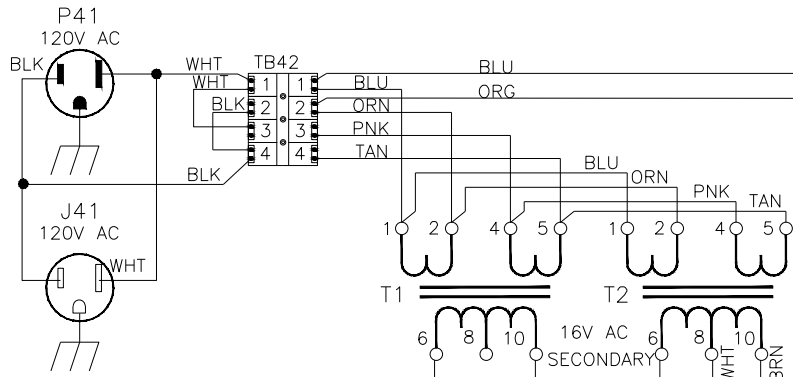

NOTE A:
8-POS DIP SWITCH.
SET THE ADDRESS PER MODEL SPECS.

NOTE 'B':
J-1041 @1 & E-1047 @2, USED FOR
EXTERNAL HORN APPLICATIONS. NOT AVAILABLE
ON SOME MODELS.

NOTE 'C':
NOT USED IN SOME MODELS.

120V AC MODELS

SPECIFICATION LABEL DATA	
MODEL NO:	(PER ORDER)
VOLTS:	120 VAC, SINGLE PHASE
WATTS:	200
AMPS:	1.7



DAKTRONICS, INC.
BROOKINGS, SD 57006

THE CONCEPTS EXPRESSED AND DETAILS SHOWN ON
THIS DRAWING ARE CONFIDENTIAL AND PROPRIETARY.
DO NOT REPRODUCE BY ANY MEANS WITHOUT THE
EXPRESSED WRITTEN CONSENT OF DAKTRONICS, INC.
COPYRIGHT 2011 DAKTRONICS, INC.

DO NOT SCALE DRAWING		PROJ: COLOR SMART LED SCOREBOARDS	
TITLE: SCHEMATIC - MCAST - 16 COL DRIVER ASSY		DRAWN: DDINING	
SCALE: NONE	DESIGN: NONE	DATE: 24 MAY 07	
SHEET	REV	JOB NO:	FUNC-TYPE-SIZE
04	P1388	R-10-A	
			306287

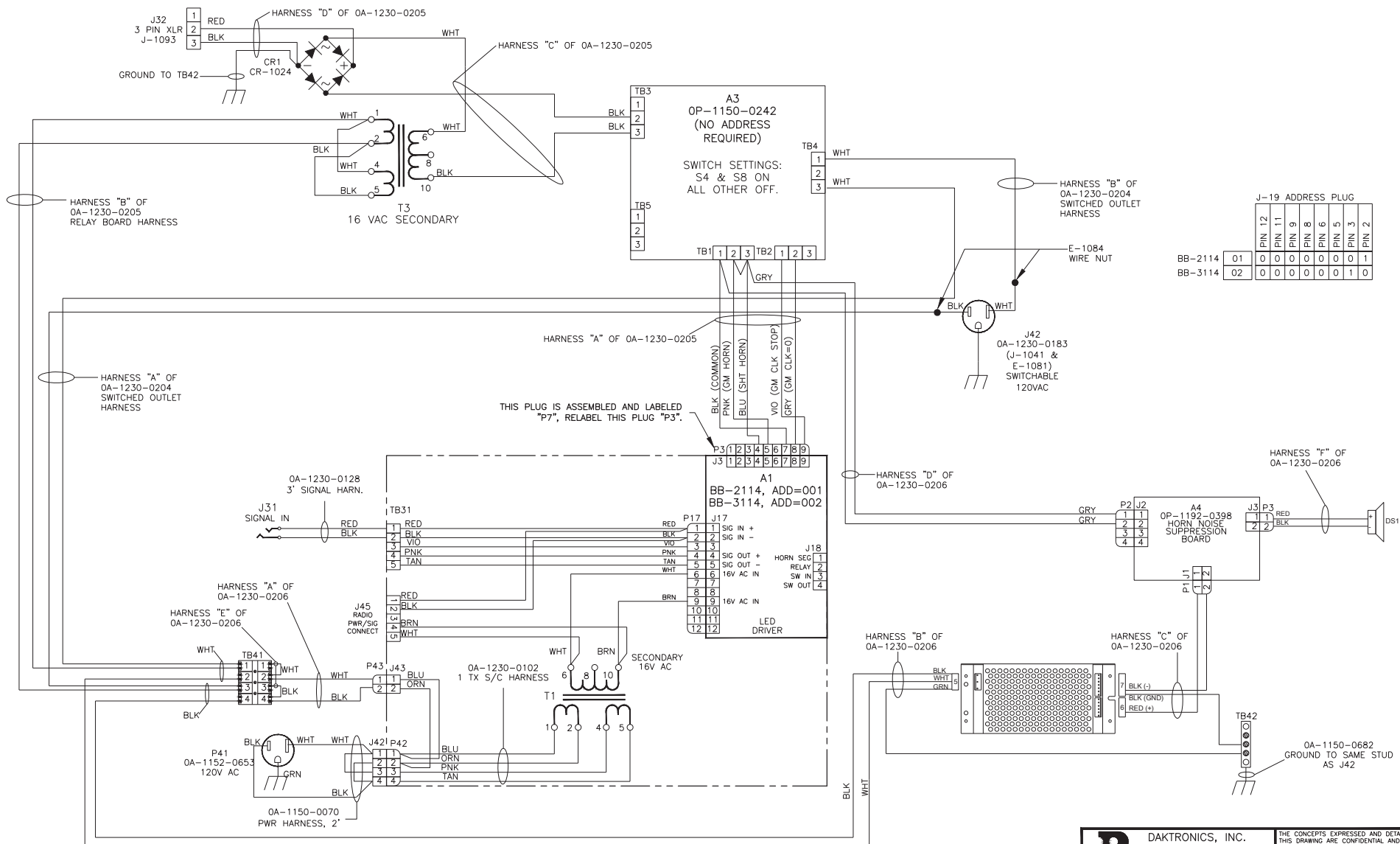

J-19 ADDRESS PLUG

	PIN 11	PIN 9	PIN 8	PIN 6	PIN 5	PIN 3	PIN 2
BB-2114	01	0	0	0	0	0	0
BB-3114	02	0	0	0	0	0	1

DAKTRONICS, INC. BROOKINGS, SD 57006 DO NOT SCALE DRAWING		THE CONCEPTS EXPRESSED AND DETAILS SHOWN ON THIS DRAWING ARE CONFIDENTIAL AND PROPRIETARY. DO NOT REPRODUCE BY ANY MEANS WITHOUT THE EXPRESSED WRITTEN CONSENT OF DAKTRONICS, INC. COPYRIGHT 2010 DAKTRONICS, INC.	
		PROJ: TUFF SPORT SCOREBOARDS TITLE: SCHEMATIC: BB-2114 / BB-3114 - 120VAC DESIGN: SBRINK DRAWN: SBRINK DATE: 15 FEB 11	
REV	DATE	DESCRIPTION	BY
03	17 DEC 12	REMOVED T-1082, CR-1024, REPL. HORN CARD -0399 W/ -0398, ADDED A-2853. PER EC-8600 - CHANGES TAKE EFFECT 01 DEC 12.	SMB
02	29 JUN 11	CHANGED J41 TO J42 ON GROUNDING NOTE AT TB42.	SMB
01	14 JUN 11	CHANGED TB42 FROM TB-1037 TO TB-1137.	SMB
SCALE: 1 = 1 SHEET REV JOB NO: FLNC-TYPE-SIZE		03 P1237 R-03-B 1045157	

Appendix E: Additional Reference Drawings

<i>Drawing Title</i>	<i>Drawing Number</i>
Signal Connection; Installation.....	A-28124
Segmentation, 7 Segment Bar Digit	A-38532
Address Table, 1 Through 128	A-115078
4 Column LED Driver II; Specifications.....	A-123783
Block Diagram: AS5000 BB- VB & WR #1	A-124686
Block Diagram: AS5000 BB- VB & WR #3	A-124688
Block Diagram- A/S 3000 or 5000 BB- VB & WR #2.....	A-125415
Block Diagram: A/S 3000 or 5000 BB- VB & WR #4	A-125417
Specifications; Driver, MCAST, 16 Col.....	A-284554
Address Table; Driver, MCAST, Address Jack.....	A-284771
Address Table; Driver, MCAST, Add DIP Switch	A-284772
Address Table; Driver- MCAST- TNMC DIP Switch.....	A-284773
Segmentation, Color or Mono 7 Segment Digit	A-308053

DISPLAY LOCATION

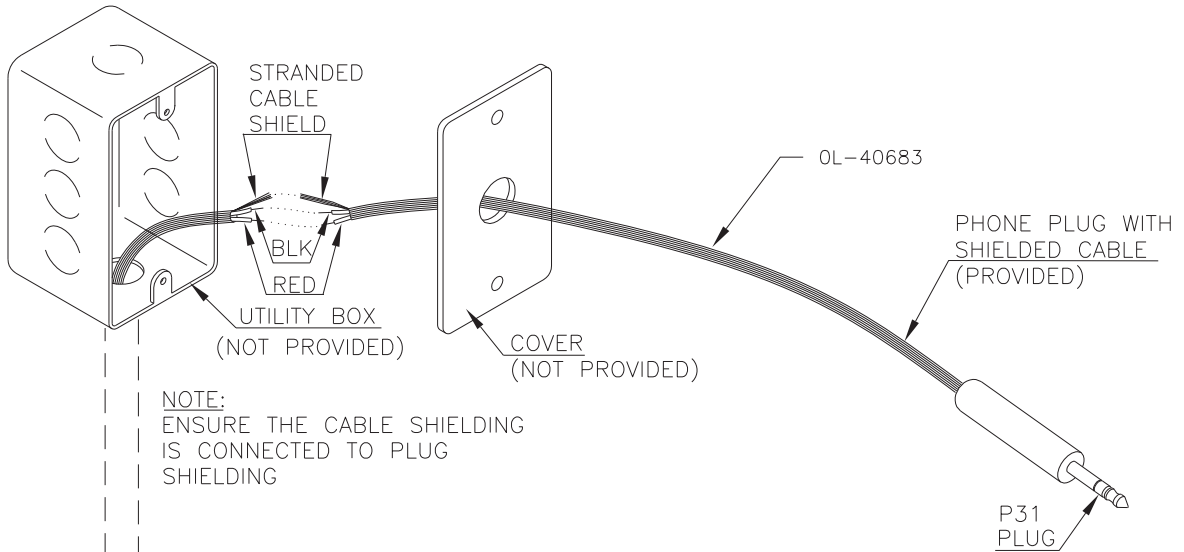

NOTE:
ENSURE THE CABLE SHIELDING
IS CONNECTED TO PLUG
SHIELDING

PROCEDURE

1. ROUTE CONDUIT BETWEEN CONTROL AND DISPLAY LOCATIONS.
2. MOUNT BOXES.
3. PULL CABLE THROUGH CONDUIT.
4. CONNECT CABLE TO J31 AND P31

J31: USE CONNECTORS PROVIDED.
INSERT WIRES INTO CONNECTOR
AND SQUEEZE CONTACT
DOWN WITH PLIERS. SNAP PLASTIC
COVER SHUT.

P31: CONNECT WIRES TO CABLE AS
FOLLOWS:

- J31 RED TO P31 RED (+)
- J31 BLK TO P31 BLK (-)
- J31 SHIELD TO P31 SHIELD

NOTE!!

DO NOT CONNECT
CABLE SHIELD AT
CONTROL CONSOLE END

SHIELDED CABLE
IN CONDUIT
(NOT PROVIDED)

TO MAIN BOARD

TO AUX BOARD

J-BOX
(PROVIDED)

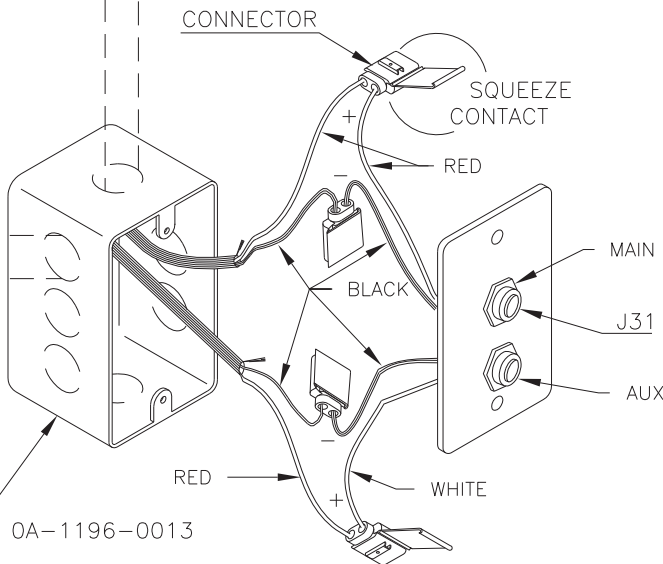

CONTROL LOCATION

REV.	DATE	DESCRIPTION	BY	APPR.
05	30 JUL 03	BOLD FACED GROUNDING NOTE	TLH	
04	17 JUN 03	CHANGED GROUNDING PROCEDURES	JJC	MWM
3	17 JAN 02	ADDED AUX TO J-BOX	JJS	
2	25 MAR 92	CHANGED WHITE TO RED	JTC	
1	05 NOV 91	REDREW ON A-SIZE ON ACAD.	JLH	

DAKTRONICS, INC. BROOKINGS, SD 57006			
PROJ: BASKETBALL			
TITLE: SIGNAL CONNECTION; INSTALLATION			
DES. BY: AVB		DRAWN BY: MHART	
		DATE: 15SEP86	
REVISION	APPR. BY: AVB	1009-R10A-28124	
05	SCALE: NONE		

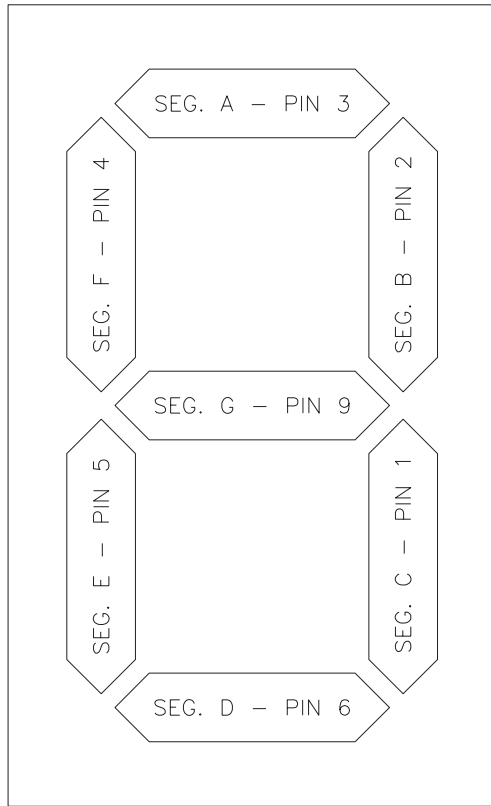

7 SEGMENT BAR DIGIT
FRONT VIEW

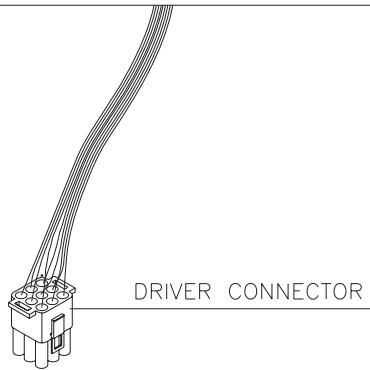

COLOR CODE		
PIN NO.	WIRE COLOR	DRIVER SEGMENT
1	ORN	C
2	RED	B
3	BRN	A
4	BLU	F
5	PNK	E
6	TAN	D
7	BLK	COM.
8	GRY	H
9	VIO	G

CONNECTOR PIN NUMBERING

NOTE SPLINE NEAR NO. 1

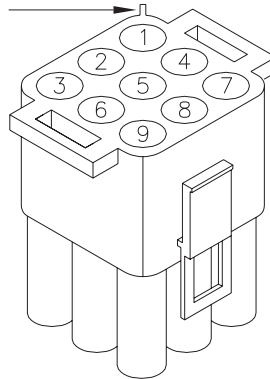

NOTE: "H" SEGMENT, GRAY WIRE IS NOT USED ON 7 SEGMENT BAR DIGIT.

THE CONCEPTS EXPRESSED AND DETAILS SHOWN ON THIS DRAWING ARE CONFIDENTIAL AND PROPRIETARY. DO NOT REPRODUCE BY ANY MEANS, INCLUDING ELECTRONICALLY WITHOUT THE EXPRESSED WRITTEN CONSENT OF DAKTRONICS, INC. COPYRIGHT 2003 DAKTRONICS, INC.

DAKTRONICS, INC. BROOKINGS, SD 57006

PROJ: BASKETBALL
TITLE: SEGMENTATION, 7 SEGMENT BAR DIGIT
DES. BY: _____ DRAWN BY: HEIDERSCHIEDT DATE: 5 JUN 89
REVISION 02 APPR. BY: AVB SCALE: 1=4
1009-R04A-38532

REV.	DATE	DESCRIPTION	BY	APPR.
2	30 APR 97	ADDED SEGMENT DESIGNATIONS TO DIGIT FIGURE.	AVB	AVB
1	2 JAN 92	CHANGED FROM B-SIZE TO A-SIZE DWG.	C FICK	

KEY: 0 = WIRE NOT CONNECTED 1 = WIRE IS CONNECTED

DECIMAL ADDRESS	PIN 12	PIN 11	PIN 9	PIN 8	PIN 6	PIN 5	PIN 3	PIN 2
1	0	0	0	0	0	0	0	1
2	0	0	0	0	0	0	1	0
3	0	0	0	0	0	0	1	1
4	0	0	0	0	0	1	0	0
5	0	0	0	0	0	1	0	1
6	0	0	0	0	0	1	1	0
7	0	0	0	0	0	1	1	1
8	0	0	0	0	1	0	0	0
9	0	0	0	0	1	0	0	1
10	0	0	0	0	1	0	1	0
11	0	0	0	0	1	1	1	1
12	0	0	0	0	1	1	0	0
13	0	0	0	0	1	1	0	1
14	0	0	0	0	1	1	1	0
15	0	0	0	0	1	1	1	1
16	0	0	0	1	0	0	0	0

DECIMAL ADDRESS	PIN 12	PIN 11	PIN 9	PIN 8	PIN 6	PIN 5	PIN 3	PIN 2
33	0	0	1	0	0	0	0	1
34	0	0	1	0	0	0	1	0
35	0	0	1	0	0	0	1	1
36	0	0	1	0	0	1	0	0
37	0	0	1	0	0	1	0	1
38	0	0	1	0	0	1	1	0
39	0	0	1	0	0	1	1	1
40	0	0	1	0	1	0	0	0
41	0	0	1	0	1	0	0	1
42	0	0	1	0	1	0	1	0
43	0	0	1	0	1	0	1	1
44	0	0	1	0	1	1	0	0
45	0	0	1	0	1	1	0	1
46	0	0	1	0	1	1	1	0
47	0	0	1	0	1	1	1	1
48	0	0	1	1	0	0	0	0

DECIMAL ADDRESS	PIN 12	PIN 11	PIN 9	PIN 8	PIN 6	PIN 5	PIN 3	PIN 2
65	0	1	0	0	0	0	0	1
66	0	1	0	0	0	0	1	0
67	0	1	0	0	0	0	1	1
68	0	1	0	0	0	1	0	0
69	0	1	0	0	0	1	0	1
70	0	1	0	0	0	1	1	0
71	0	1	0	0	0	1	1	1
72	0	1	0	0	1	0	0	0
73	0	1	0	0	1	0	0	1
74	0	1	0	0	1	0	1	0
75	0	1	0	0	1	0	1	1
76	0	1	0	0	1	1	0	0
77	0	1	0	0	1	1	0	1
78	0	1	0	0	1	1	1	0
79	0	1	0	0	1	1	1	1
80	0	1	0	1	0	0	0	0

DECIMAL ADDRESS	PIN 12	PIN 11	PIN 9	PIN 8	PIN 6	PIN 5	PIN 3	PIN 2
97	0	1	1	0	0	0	0	1
98	0	1	1	0	0	0	1	0
99	0	1	1	0	0	0	1	1
100	0	1	1	0	0	1	0	0
101	0	1	1	0	0	1	0	1
102	0	1	1	0	0	1	1	0
103	0	1	1	0	0	1	1	1
104	0	1	1	0	1	0	0	0
105	0	1	1	0	1	0	0	1
106	0	1	1	0	1	0	1	0
107	0	1	1	0	1	0	1	1
108	0	1	1	0	1	1	0	0
109	0	1	1	0	1	1	0	1
110	0	1	1	0	1	1	1	0
111	0	1	1	0	1	1	1	1
112	0	1	1	1	0	0	0	0

DECIMAL ADDRESS	PIN 12	PIN 11	PIN 9	PIN 8	PIN 6	PIN 5	PIN 3	PIN 2
17	0	0	0	1	0	0	0	1
18	0	0	0	1	0	0	1	0
19	0	0	0	1	0	0	1	1
20	0	0	0	1	0	1	0	0
21	0	0	0	1	0	1	0	1
22	0	0	0	1	0	1	1	0
23	0	0	0	1	0	1	1	1
24	0	0	0	1	1	0	0	0
25	0	0	0	1	1	0	0	1
26	0	0	0	1	1	0	1	0
27	0	0	0	1	1	0	1	1
28	0	0	0	1	1	1	0	0
29	0	0	0	1	1	1	0	1
30	0	0	0	1	1	1	1	0
31	0	0	0	1	1	1	1	1
32	0	0	1	0	0	0	0	0

DECIMAL ADDRESS	PIN 12	PIN 11	PIN 9	PIN 8	PIN 6	PIN 5	PIN 3	PIN 2
49	0	0	1	1	0	0	0	1
50	0	0	1	1	0	0	1	0
51	0	0	1	1	0	0	1	1
52	0	0	1	1	0	1	0	0
53	0	0	1	1	0	1	0	1
54	0	0	1	1	0	1	1	0
55	0	0	1	1	0	1	1	1
56	0	0	1	1	1	0	0	0
57	0	0	1	1	1	0	0	1
58	0	0	1	1	1	0	1	0
59	0	0	1	1	1	0	1	1
60	0	0	1	1	1	1	0	0
61	0	0	1	1	1	1	0	1
62	0	0	1	1	1	1	1	0
63	0	0	1	1	1	1	1	1
64	0	1	0	0	0	0	0	0

DECIMAL ADDRESS	PIN 12	PIN 11	PIN 9	PIN 8	PIN 6	PIN 5	PIN 3	PIN 2
81	0	1	0	1	0	0	0	1
82	0	1	0	1	0	0	1	0
83	0	1	0	1	0	0	1	1
84	0	1	0	1	0	1	0	0
85	0	1	0	1	0	1	0	1
86	0	1	0	1	0	1	1	0
87	0	1	0	1	0	1	1	1
88	0	1	0	1	1	0	0	0
89	0	1	0	1	1	0	0	1
90	0	1	0	1	1	0	1	0
91	0	1	0	1	1	0	1	1
92	0	1	0	1	1	1	0	0
93	0	1	0	1	1	1	0	1
94	0	1	0	1	1	1	1	0
95	0	1	0	1	1	1	1	1
96	0	1	1	0	0	0	0	0

DECIMAL ADDRESS	PIN 12	PIN 11	PIN 9	PIN 8	PIN 6	PIN 5	PIN 3	PIN 2
113	0	1	1	1	0	0	0	1
114	0	1	1	1	0	0	1	0
115	0	1	1	1	0	0	1	1
116	0	1	1	1	0	1	0	0
117	0	1	1	1	0	1	0	1
118	0	1	1	1	0	1	1	0
119	0	1	1	1	0	1	1	1
120	0	1	1	1	1	0	0	0
121	0	1	1	1	1	0	0	1
122	0	1	1	1	1	0	1	0
123	0	1	1	1	1	0	1	1
124	0	1	1	1	1	1	0	0
125	0	1	1	1	1	1	0	1
126	0	1	1	1	1	1	1	0
127	0	1	1	1	1	1	1	1
128	1	0	0	0	0	0	0	0

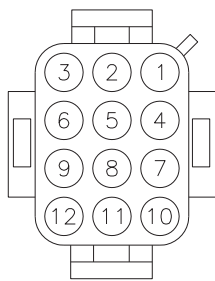

ADDRESS PLUG
WIRE SIDE

WIRING DIAGRAM
ADDRESS PLUG
WITH ALL WIRES
CONNECTED

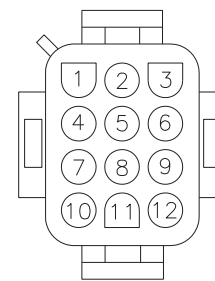

BOTTOM VIEW

DAKTRONICS, INC. BROOKINGS, SD 57006

PROJ:
TITLE: ADDRESS TABLE, 1 THROUGH 128
DES. BY: AVB DRAWN BY: A VANBEMMEL DATE: 28 APR 99

REVISION 01 APPR. BY: SCALE: NONE 1150-R04A-115078

REV.	DATE	DESCRIPTION	BY	APPR.
01	08 MAR 05	ADDED BOTTOM VIEW	KQB	

KEY: 0 = WIRE NOT CONNECTED 1 = WIRE IS CONNECTED TO ANY GROUND PIN (1,4,7,10)
J19 ADDRESS AND COLUMN SELECT JACK

DECIMAL ADDRESS	1	0	0	0	0	1	DECIMAL ADDRESS	17	1	0	0	0	1
	2	0	0	0	1	0		18	1	0	0	1	0
	3	0	0	0	1	1		19	1	0	0	1	1
	4	0	0	1	0	0		20	1	0	1	0	0
	5	0	0	1	0	1		21	1	0	1	0	1
	6	0	0	1	1	0		22	1	0	1	1	0
	7	0	0	1	1	1		23	1	0	1	1	1
	8	0	1	0	0	0		24	1	1	0	0	0
	9	0	1	0	0	1		25	1	1	0	0	1
	10	0	1	0	1	0		26	1	1	0	1	0
	11	0	1	0	1	1		27	1	1	0	1	1
	12	0	1	1	0	0		28	1	1	1	0	0
	13	0	1	1	0	1		29	1	1	1	0	1
	14	0	1	1	1	0		30	1	1	1	1	0
	15	0	1	1	1	1		31	1	1	1	1	1
	16	1	0	0	0	0							

TIME OF DAY SELECT	PIN 9
DISABLE	0
ENABLE	1

COLUMN SELECT	PIN 12	PIN 11
COLUMNS 5-8	0	0
COLUMNS 1-4	0	1
COLUMNS 9-12	1	0
COLUMNS 13-16	1	1

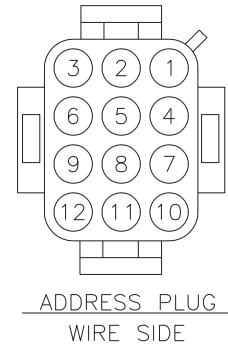

WIRING DIAGRAM
 ADDRESS PLUG
 WITH ALL WIRES
 CONNECTED



J17 MAIN	
PIN	FUNCTION
1	SIG-P
2	SIG-N
3	GND-N
4	CLOUT-P
5	CLOUT-N
6	16VAC-N
7	GND-N
8	EARTH-N
9	16VAC-P
10	GND-N
11	SWIN-P
12	SWIN-N

J1-4 DIGIT	
PIN	FUNCTION
1	SEGC-N
2	SEGB-N
3	SEGA-N
4	SEGF-N
5	SEGE-N
6	SEGD-N
7	+VCC-P
8	SEGH-N
9	SEGG-N

J19 ADDRESS	
PIN	FUNCTION
1	GND-N
2	ADD0-N
3	ADD1-N
4	GND-N
5	ADD2-N
6	ADD3-N
7	GND-N
8	ADD4-N
9	ADD5-N
10	GND-N
11	COLS1-N
12	COLS2-N

J6 RELAY	
PIN	FUNCTION
1	HORNOUT-N
2	AUXOUT-N
3	120SW-P
4	120SW-N

J7 RELAY	
PIN	FUNCTION
1	N/C
2	AUXOUT-N
3	120SW-P
4	120SW-N

OP-1150-0130 UNCOATED OR OP-1150-0131
 COATED 4 COLUMN LED DRIVER II

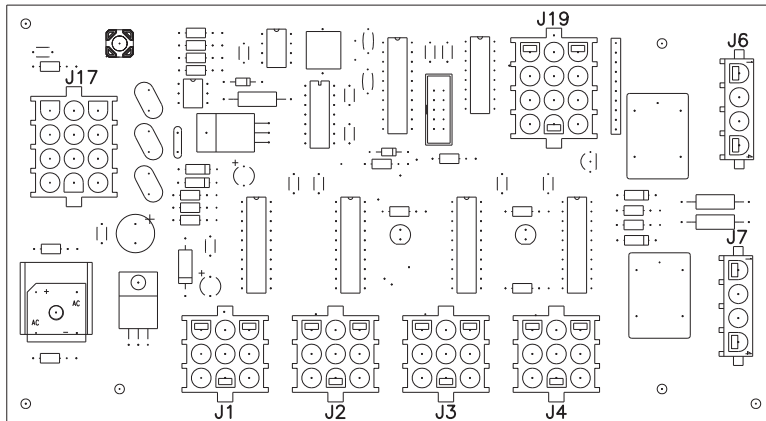

NOTE
 -WITH NO ADDRESS PINS SELECTED THE DRIVER WILL DEFAULT TO A/S 4000 PROTOCOL
 -COLUMN SELECT PINS WORK FOR EITHER A/S 4000 OR A/S 5000 PROTOCOL
 -DRIVER WILL DEFAULT TO COLUMNS 5-8
 -GREEN LED INDICATES THE DRIVER HAS POWER
 -RED LED WILL BE ON OR BLINKING WHEN THE DRIVER IS RECEIVING SIGNAL
 -REDRIVE CIRCUIT IS PROCESSOR REFRESHED (REFER TO DWG A-128429 FOR FURTHER INFORMATION ON THE CURRENT LOOP REDRIVE CIRCUIT SPECIFICATIONS)

DATA INPUT DIGIT NUMBER	COLUMN SELECT 0 NO JUMPER CONNECTIONS				COLUMN SELECT 1 CONNECT J19 PIN 10 TO 11				COLUMN SELECT 2 CONNECT J19 PIN 10 TO 12				COLUMN SELECT 3 CONNECT J19 PIN 10 TO 11&12			
	5	6	7	8	1	2	3	4	9	10	11	12	13	14	15	16
DIGIT OUTPUT CONNECTOR	1	2	3	4	1	2	3	4	1	2	3	4	1	2	3	4

ALSO, COLUMN SELECT #1 MAKES THESE CHANGES:
 INPUT DATA DIGIT 5, SEGMENT H IS SENT TO DIGIT OUTPUT NO. 1, SEGMENT H.
 INPUT DATA DIGIT 9, SEGMENT H IS SENT TO DIGIT OUTPUT NO. 2, SEGMENT H.

3	21 DEC 00	ADDED HORN SEGMENT INFORMATION	EB	DAKTRONICS, INC. BROOKINGS, SD 57006		
2	2 OCT 00	CHANGED TIME OF DAY ENABLE TO DISABLE (0) AND ENABLE (1)	NSW	PROJ:		
1	29 SEP 00	REMOVED "STAND ALONE" FROM WORDING FOR TIME OF DAY ENABLE.	AVB	TITLE: 4 COLUMN LED DRIVER II; SPECIFICATIONS		
REV.	DATE	DESCRIPTION	BY	DES. BY: EB	DRAWN BY: E BRAVEK	DATE: 08 NOV 99
			APPR.	REVISION 03	APPR. BY:	SCALE: NONE
				1150-R04A-123783		

TYPICAL INSTALLATION SHOWN

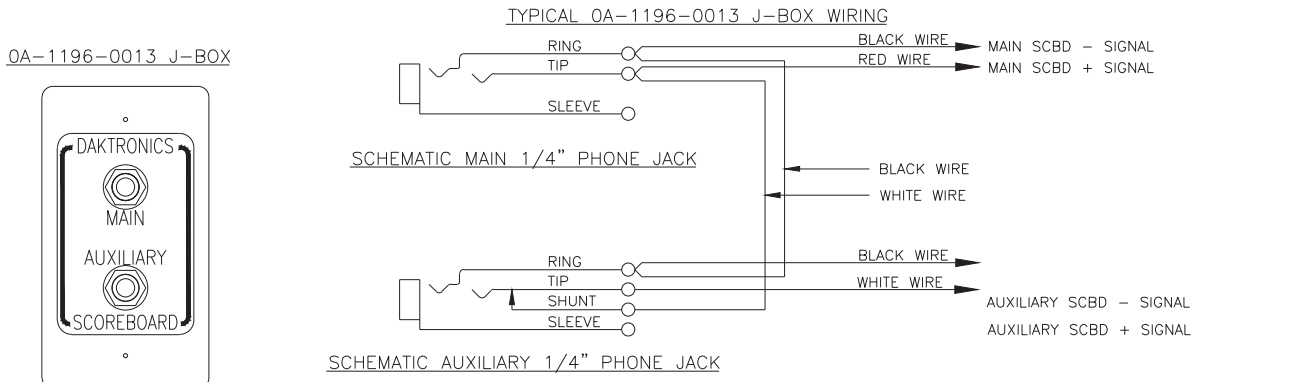
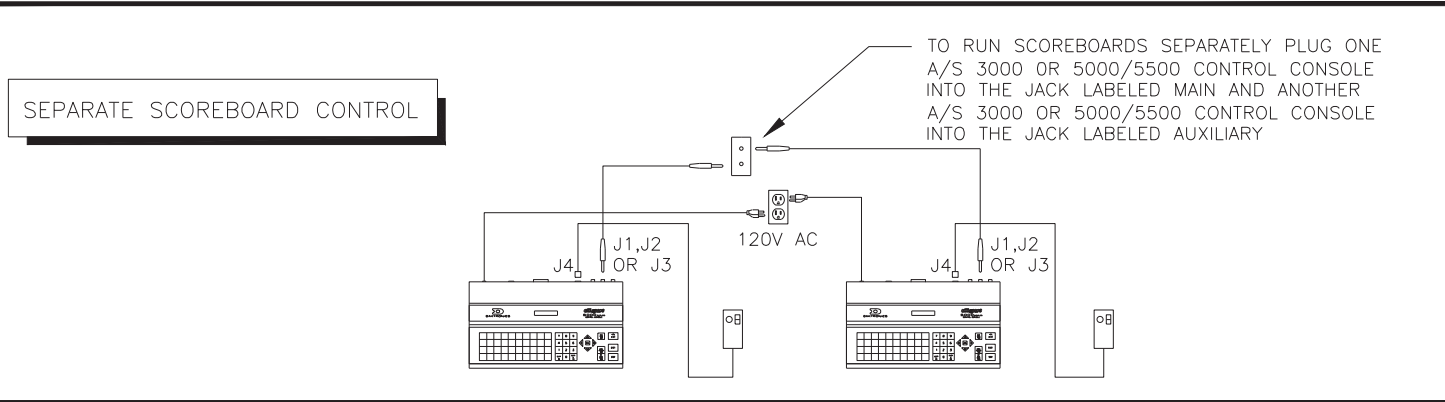
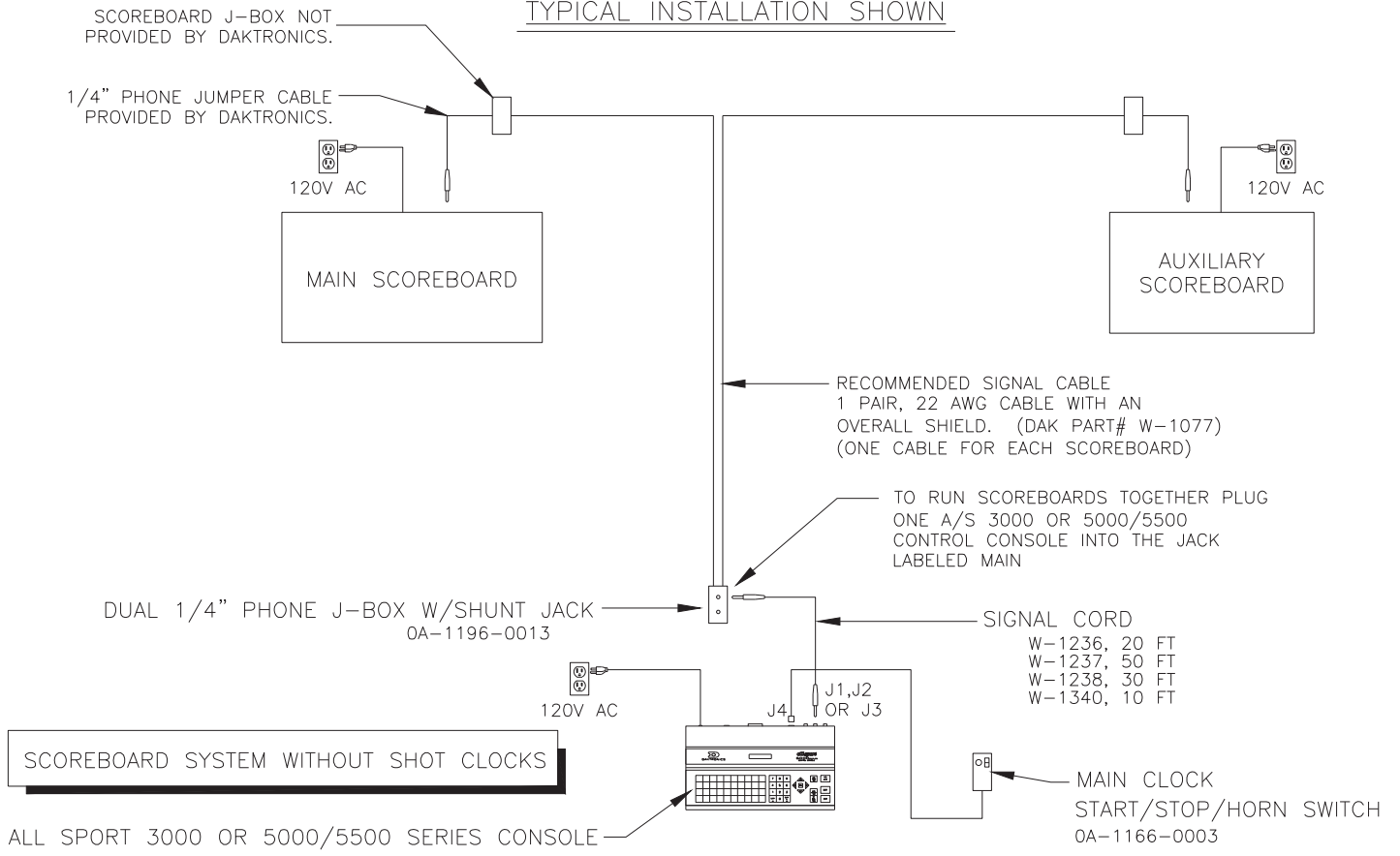

	DAKTRONICS, INC. BROOKINGS, SD 57006	THE CONCEPTS EXPRESSED AND DETAILS SHOWN ON THIS DRAWING ARE CONFIDENTIAL AND PROPRIETARY. DO NOT REPRODUCE BY ANY MEANS WITHOUT THE EXPRESSED WRITTEN CONSENT OF DAKTRONICS, INC. COPYRIGHT 2011 DAKTRONICS, INC.
DO NOT SCALE DRAWING		
PROJ: ALL SPORT 5000/5500		
TITLE: BLOCK DIAGRAM: AS5000 BB- VB AND WR #1		
DESIGN:	DRAWN: E BRAVEK	DATE: 29 NOV 99
SCALE: NONE		
SHEET	REV	JOB NO:
	02	P1196
		FUNC-TYPE-SIZE
		R-04-A
124686		

REV 02	DATE: 17 AUG 11	UPDATED THE BOARDER AND TITLE BLOCK UPDATED TEXT TO INCLUDE 5500 SERIES	BY: JJL
REV 01	DATE: 26 APR 00	ADDED A/S 3000	BY: DKD

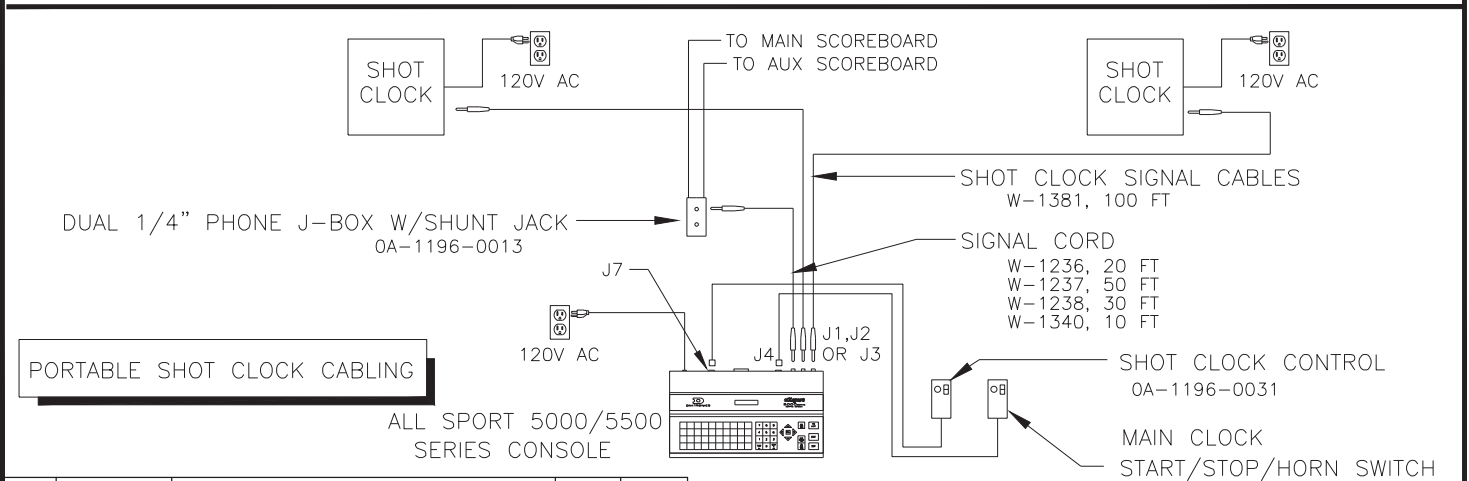
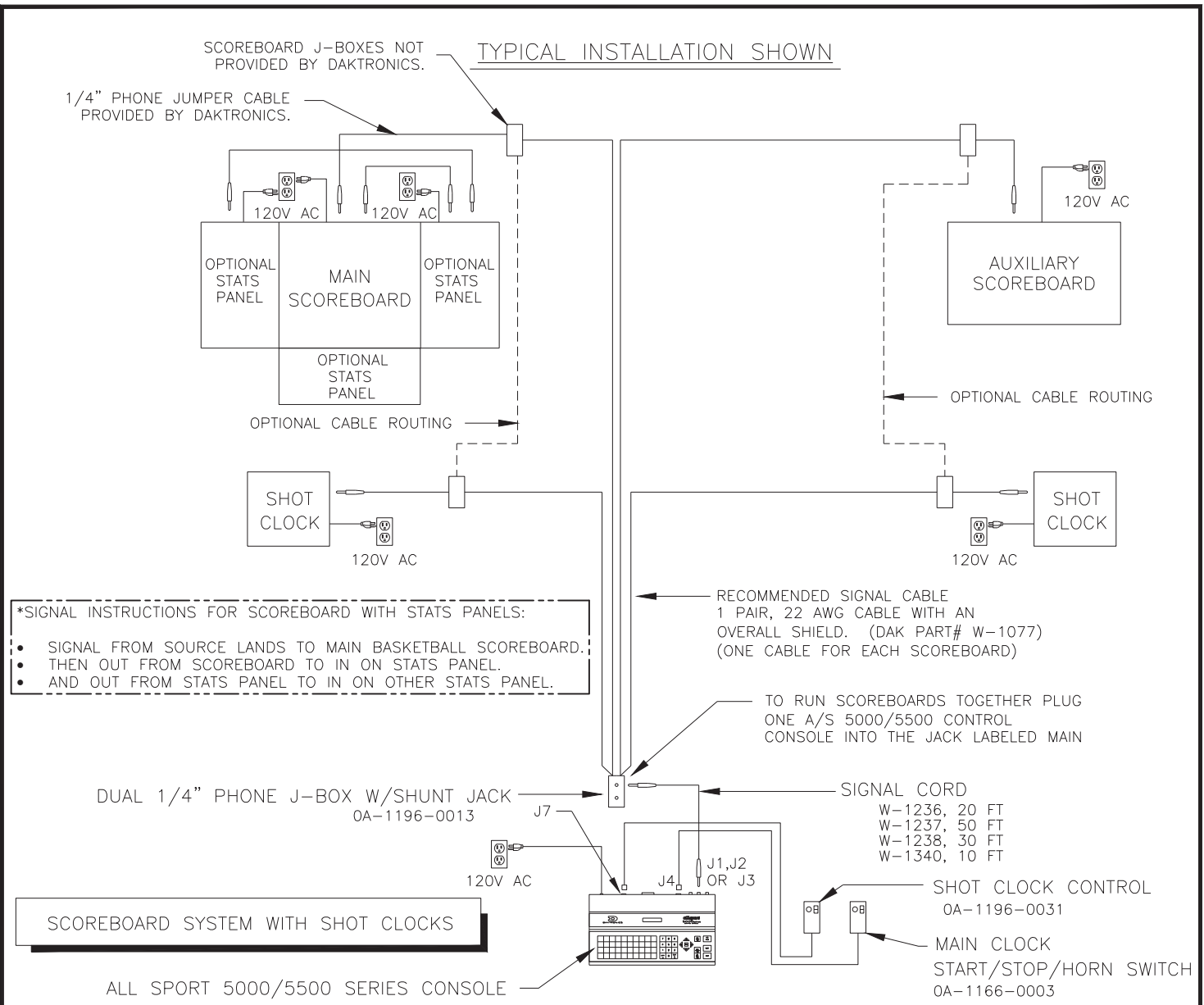

REV 06	DATE: 02 MAR 12	ADDED CORRECT SIGNAL ROUTING FOR SCBDD WITH STATS PANELS.	BY: SMB
REV 5	DATE: 17 AUG 11	UPDATED THE BOARDER AND TITLE BLOCK. UPDATED DRAWING TO INCLUDE 5500 SERIES	BY: JJJ
4	17 JAN 02	CHANGED 0A-1166-0004 TO 0A-1196-0031	JJS
3	06 SEP 01	ADDED BOTTOM OPTIONAL STATS PANEL TO MAIN BOARD, AND ADDED SIGNAL CABLES TO AND FROM OPTIONAL STATS PANELS.	NW
2	14 DEC 00	ADDED 120VAC TO SIDE BOARDS OF MAIN SCOREBOARD	NSW
1	29 DEC 99	ADDED SHOT CLOCK REMOTE START/STOP TO TOP A/S5000 CONTROLLER	EB

DAKTRONICS, INC.
BROOKINGS, SD 57006

DO NOT SCALE DRAWING

Proj: ALL SPORT 5000/5500

Title: BLOCK DIAGRAM: AS5000 BB- VB AND WR #3

DESIGN: _____ DRAWN: E BRAVEK DATE: 29 NOV 99

SCALE: NONE

SHEET	REV	JOB NO:	FUNC-TYPE-SIZE
	06	P1196	R-04-A

124688

THE CONCEPTS EXPRESSED AND DETAILS SHOWN ON THIS DRAWING ARE CONFIDENTIAL AND PROPRIETARY. DO NOT REPRODUCE BY ANY MEANS WITHOUT THE EXPRESSED WRITTEN CONSENT OF DAKTRONICS, INC. COPYRIGHT 2011 DAKTRONICS, INC.

TYPICAL INSTALLATION SHOWN

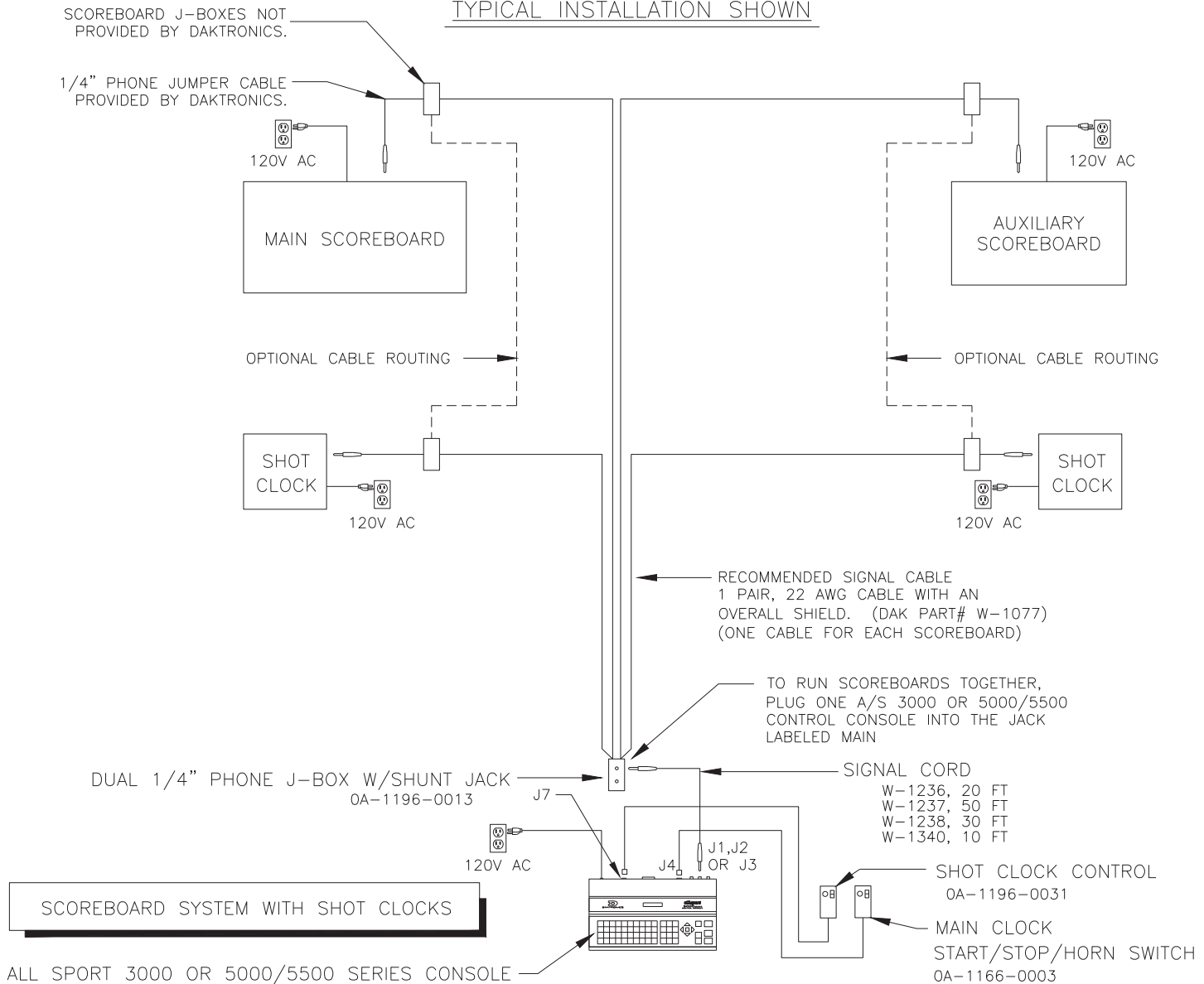

0A-1196-0013 J-BOX

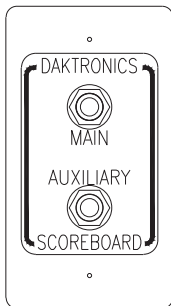

TYPICAL 0A-1196-0013 J-BOX WIRING

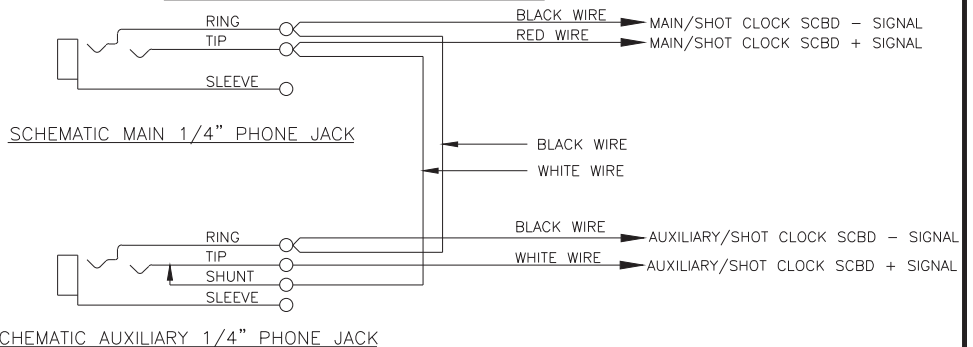

REV 04	DATE: 24 AUG 11	UPDATED TEXT TO INCLUDE 5500 SERIES UPDATED TITLE BLOCK	BY: JJL
3	17 JAN 02	CHANGED 0A-1166-4 TO 0A-1196-31	JJS
02	26 APR 00	ADDED A/S 3000	DKD
1	29 DEC 99	ADDED SHOT CLOCK REMOTE START STOP TO A/S 5000 CONTROLLER	EB

<p>DAKTRONICS, INC. BROOKINGS, SD 57006</p>		<p>THE CONCEPTS EXPRESSED AND DETAILS SHOWN ON THIS DRAWING ARE CONFIDENTIAL AND PROPRIETARY. DO NOT REPRODUCE BY ANY MEANS WITHOUT THE EXPRESSED WRITTEN CONSENT OF DAKTRONICS, INC. COPYRIGHT 2011 DAKTRONICS, INC.</p>	
DO NOT SCALE DRAWING			
PROJ: ALL SPORT 5000/5500			
TITLE: BLOCK DIAGRAM- A/S 3000 OR 5000 BB- VB AND WR #2			
DESIGN:	DRAWN: E BRAVEK	DATE: 15 DEC 99	
SCALE: NONE			
SHEET	REV	JOB NO:	FUNC-TYPE-SIZE
	04	P1196	R-04-A
			125415

01	26 APR 00	ADDED A/S 3000	DKD
02	31 JAN 07	UPDATED DRAWING TO SHOW SECOND ALL SPORT	MMM
03	18 DEC 08	UPDATED DRAWING WITH PROPER SHIELDING	DKD
04	24 AUG 11	UPDATED DRAWING TO INCLUDE 5500 SERIES UPDATED TITLE BLOCK	JLL

PROJ: ALL SPORT 5000/5500	DO NOT SCALE DRAWING	DAKTRONICS, INC. BROOKINGS, SD 57006
TITLE: BLOCK DIAGRAM: A/S 3000 OR 5000 BB-VB AND WR #4	DESIGN: EBRAVEK	THE CONCEPTS EXPRESSED AND DETAILS SHOWN ON THIS DRAWING ARE CONFIDENTIAL AND PROPRIETARY. DO NOT REPRODUCE BY ANY MEANS WITHOUT THE EXPRESSED WRITTEN CONSENT OF DAKTRONICS, INC. COPYRIGHT 2011 DAKTRONICS, INC.
SCALE: NONE	DRAWN: EBRAVEK	DATE: 24 JAN 00
SHEET	REV 04	JOB NO: P1196
		FUNC-TYPE-SIZE: R-01-A
		125417

TYPICAL INSTALLATION SHOWN

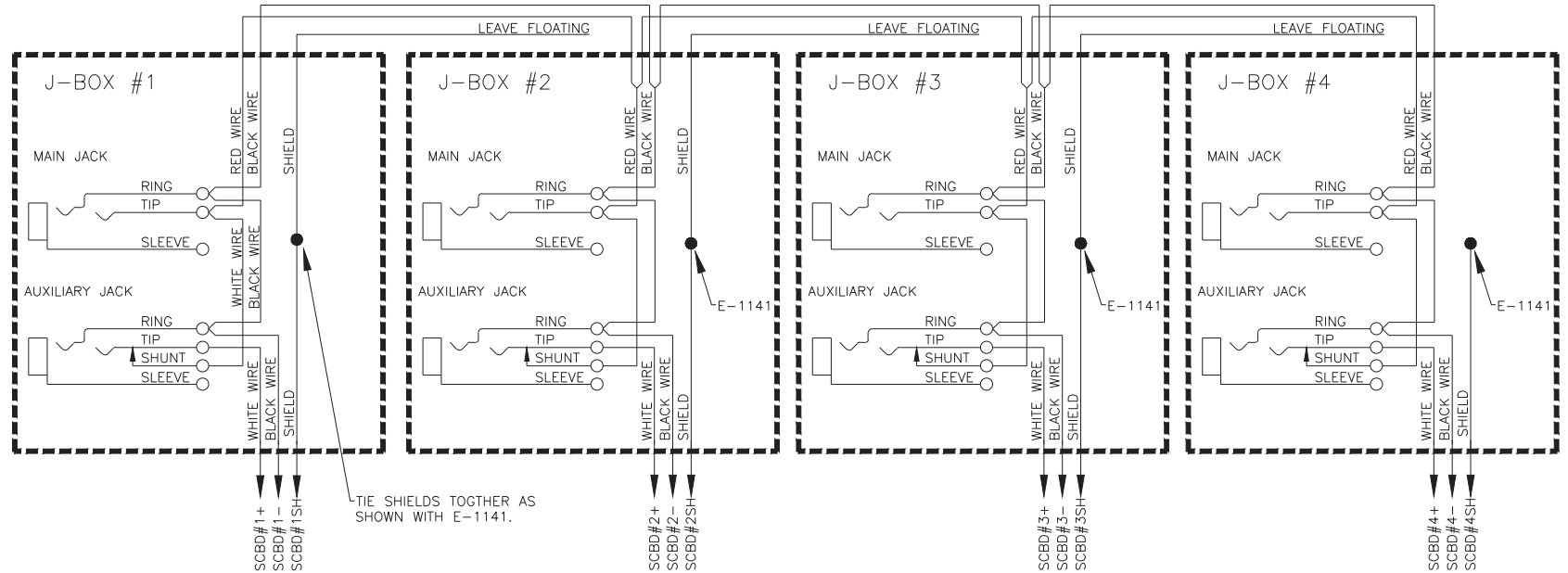
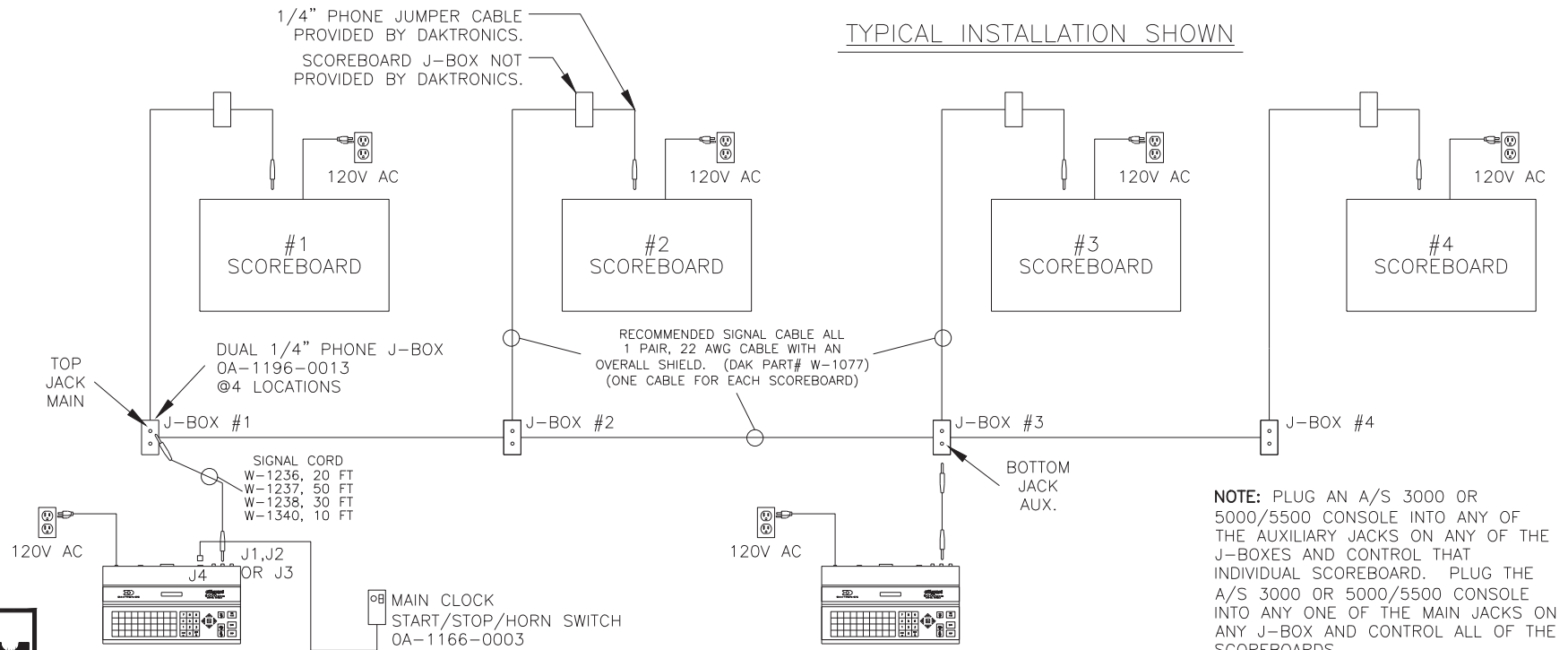

COLOR SMART DRIVER

OP-1388-0100

J1-16 DIGITS

PIN	FUNCTION
1	SEGA-N
2	SEGB-N
3	SEGC-N
4	SEGD-N
5	SEGE-N
6	SEGF-N
7	SEGG-N
8	SEGH-N
9	+V1
10	+V2

J18 PWR OUT

PIN	FUNCTION
1	20VDC
2	10VDC
3	GND-N

J24 POWER IN

PIN	FUNCTION
5	+VDD-P
4	GND-N
3	XFMR-CT
2	GND-N
1	+VBB-P

J22 PROGRAM JACK

PIN	FUNCTION
1	PGC
2	/MCLR
3	N/C
4	GND-N
5	PGD
6	GND-N
7	PGM
8	+5V-P
9	N/C
10	N/C

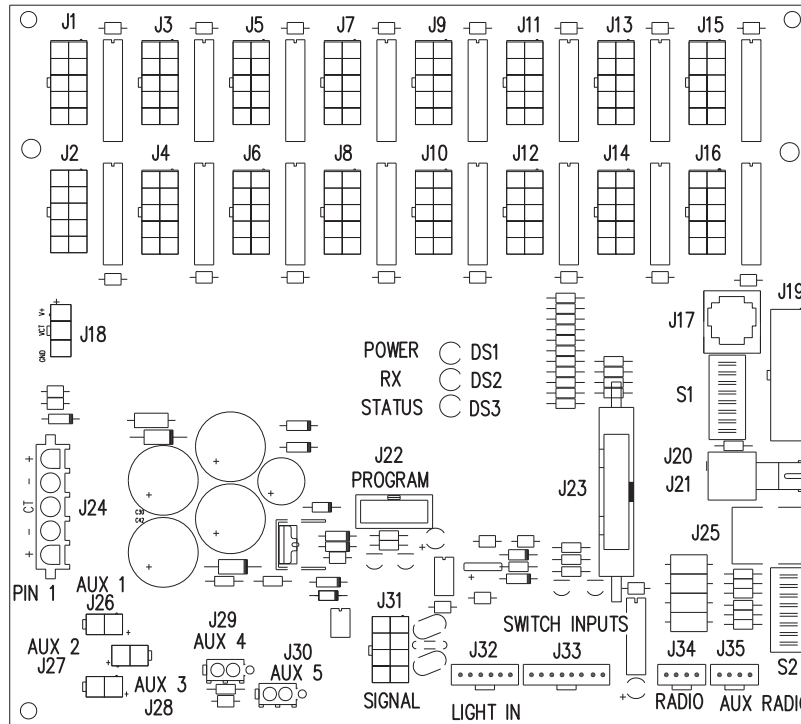

S1 - DIP SWITCH FOR MAIN ADDRESS
 [SW1] [SW2] [SW3] [SW4] [SW5] [SW6] [SW7] [SW8]

UP TO 127 ADDRESS

SW8 - T.O.D. ON ENABLED

J20 OR J21 - FIBER RX

J23 TEAM NAME OUTPUT

FUNCTION	PIN	PIN	FUNCTION
GND4-P	11	10	ID3
RED4-P	12	9	ID2
GND3-P	13	8	GND-N
MTRX_CLK	14	7	GND-N
RED3-P	15	6	GRN2-P
RED2-P	16	5	GND-N
MTRX_DIM	17	4	GND-N
MTRX_LT	18	3	GND-N
GND1-P	19	2	ID1
RED1-P	20	1	ID0

S2 - DIP SWITCH FOR TNMC ADDRESS

[SW1] [SW2] [SW3] [SW4] [SW5] [SW6] [SW7] [SW8]

0 TO 15 ADDRESS SPARES

SW5 - HOME OR GUEST SELECT
 OFF = HOME
 ON = GUEST

J26-28 (AUX 1 - 3)

PIN	FUNCTION
1	20VDC
2	SWITCHED-N

LOW CURRENT CONNECTION (200MA)

J29,30 (AUX 4 & 5)

PIN	FUNCTION
1	SWITCHING IN
2	SWITCHING OUT

SECONDARY TXFMR AC VOLTAGES TYPICAL (1.5AMP)

J31 SIGNAL

PIN	FUNCTION
1	SIG-P
2	SIG-N
3	CLOUT-P
4	CLOUT-N
5	LIGHT_0-P
6	LIGHT_0-N
7	LIGHT_IN-P
8	LIGHT_IN-N

J32 LIGHT SENSOR

PIN	FUNCTION
1	LIGHT_IN-P
2	LIGHT_IN-N
3	+5V-P
4	GND-N
5	GND-N
6	232_IN-P

J34 RADIO (MAIN)

PIN	FUNCTION
1	+UNREG-P
2	GND-N
3	GND-N
4	INPUT-P

J35 RADIO (AUX)

PIN	FUNCTION
1	+UNREG-P
2	GND-N
3	GND-N
4	INPUT-P

J33 SW INPUTS

PIN	FUNCTION
1	SW_IN0-P
2	GND-N
3	SW_IN1-P
4	GND-N
5	SW_IN2-P
6	GND-N
7	SW_IN3-P
8	GND-N

J17 TPIC OUT

PIN	FUNCTION
1	+5V-P
2	SDO-P
3	CLK-P
4	STROBE-P
5	/OE-P
6	REDE_GRNO
7	REDO_GRNE
8	GND-N

J25 RS422

PIN	FUNCTION
1	N/C
2	N/C
3	CME_A
4	CME_B
5	CME_Z
6	CME_Y
7	GND-N
8	+5V-P

J19 WIRED ADDRESS JACK

FUNCTION	PIN	PIN	FUNCTION
GND-N	9	1	ADD0-N
GND-N	10	2	ADD1-N
GND-N	11	3	ADD2-N
GND-N	12	4	ADD3-N
GND-N	13	5	ADD4-N
GND-N	14	6	ADD5-N
GND-N	15	7	ADD6-N
GND-N	16	8	TOD

NOTES:

- GREEN LED DS1 INDICATES THAT THE DRIVER HAS POWER.
- RED LED DS2 WILL FLICKER WHEN THE DRIVER RECEIVES SIGNAL.
- AMBER LED DS3 WILL BLINK WHEN THE DRIVER IS RUNNING.
- IF DS3 IS ON OR OFF CONTINUOUSLY THE MICROCONTROLLER IS NOT WORKING.
- REFER TO THE FOLLOWING DRAWINGS FOR ADDRESS AND SWITCH SETTINGS:

ADDRESS JACK (J19) A-284771

ADDRESS SWITCH (S1) A-284772

TNMC ADD SWITCH (S2) A-284773

NOT USED/NOT LOADED ON SOME MODELS

THE CONCEPTS EXPRESSED AND DETAILS SHOWN ON THIS DRAWING ARE CONFIDENTIAL AND PROPRIETARY. DO NOT REPRODUCE BY ANY MEANS, INCLUDING ELECTRONICALLY WITHOUT THE EXPRESSED WRITTEN CONSENT OF DAKTRONICS, INC. COPYRIGHT 2006 DAKTRONICS, INC.

DAKTRONICS, INC. BROOKINGS, SD 57006

PROJ:

TITLE: SPECIFICATIONS; DRIVER, MCAST, 16 COL

DES. BY:

DRAWN BY: DULSCHM

DATE: 11 SEP 06

REVISION

APPR. BY:

00

SCALE: 1 = 2

1388-R04A-284554

REV.	DATE	DESCRIPTION	BY	APPR.

DECIMAL ADDRESS	PIN 7	PIN 6	PIN 5	PIN 4	PIN 3	PIN 2	PIN 1
1	0	0	0	0	0	0	1
2	0	0	0	0	0	1	0
3	0	0	0	0	0	1	1
4	0	0	0	0	1	0	0
5	0	0	0	0	1	0	1
6	0	0	0	0	1	1	0
7	0	0	0	0	1	1	1
8	0	0	0	1	0	0	0
9	0	0	0	1	0	0	1
10	0	0	0	1	0	1	0
11	0	0	0	1	0	1	1
12	0	0	0	1	1	0	0
13	0	0	0	1	1	0	1
14	0	0	0	1	1	1	0
15	0	0	0	1	1	1	1
16	0	0	1	0	0	0	0

DECIMAL ADDRESS	PIN 7	PIN 6	PIN 5	PIN 4	PIN 3	PIN 2	PIN 1
33	0	1	0	0	0	0	1
34	0	1	0	0	0	1	0
35	0	1	0	0	0	1	1
36	0	1	0	0	1	0	0
37	0	1	0	0	1	0	1
38	0	1	0	0	1	1	0
39	0	1	0	0	1	1	1
40	0	1	0	1	0	0	0
41	0	1	0	1	0	0	1
42	0	1	0	1	0	1	0
43	0	1	0	1	0	1	1
44	0	1	0	1	1	0	0
45	0	1	0	1	1	0	1
46	0	1	0	1	1	1	0
47	0	1	0	1	1	1	1
48	0	1	1	0	0	0	0

DECIMAL ADDRESS	PIN 7	PIN 6	PIN 5	PIN 4	PIN 3	PIN 2	PIN 1
65	1	0	0	0	0	0	1
66	1	0	0	0	0	1	0
67	1	0	0	0	0	1	1
68	1	0	0	0	1	0	0
69	1	0	0	0	1	0	1
70	1	0	0	0	1	1	0
71	1	0	0	0	1	1	1
72	1	0	0	1	0	0	0
73	1	0	0	1	0	0	1
74	1	0	0	1	0	1	0
75	1	0	0	1	0	1	1
76	1	0	0	1	1	0	0
77	1	0	0	1	1	0	1
78	1	0	0	1	1	1	0
79	1	0	0	1	1	1	1
80	1	0	1	0	0	0	0

DECIMAL ADDRESS	PIN 7	PIN 6	PIN 5	PIN 4	PIN 3	PIN 2	PIN 1
97	1	1	0	0	0	0	1
98	1	1	0	0	0	1	0
99	1	1	0	0	0	1	1
100	1	1	0	0	1	0	0
101	1	1	0	0	1	0	1
102	1	1	0	0	1	1	0
103	1	1	0	0	1	1	1
104	1	1	0	1	0	0	0
105	1	1	0	1	0	0	1
106	1	1	0	1	0	1	0
107	1	1	0	1	0	1	1
108	1	1	0	1	1	0	0
109	1	1	0	1	1	0	1
110	1	1	0	1	1	1	0
111	1	1	0	1	1	1	1
112	1	1	1	0	0	0	0

DECIMAL ADDRESS	PIN 7	PIN 6	PIN 5	PIN 4	PIN 3	PIN 2	PIN 1
17	0	0	1	0	0	0	1
18	0	0	1	0	0	1	0
19	0	0	1	0	0	1	1
20	0	0	1	0	1	0	0
21	0	0	1	0	1	0	1
22	0	0	1	0	1	1	0
23	0	0	1	0	1	1	1
24	0	0	1	1	0	0	0
25	0	0	1	1	0	0	1
26	0	0	1	1	0	1	0
27	0	0	1	1	0	1	1
28	0	0	1	1	1	0	0
29	0	0	1	1	1	0	1
30	0	0	1	1	1	1	0
31	0	0	1	1	1	1	1
32	0	1	0	0	0	0	0

DECIMAL ADDRESS	PIN 7	PIN 6	PIN 5	PIN 4	PIN 3	PIN 2	PIN 1
49	0	1	1	0	0	0	1
50	0	1	1	0	0	1	0
51	0	1	1	0	0	1	1
52	0	1	1	0	1	0	0
53	0	1	1	0	1	0	1
54	0	1	1	0	1	1	0
55	0	1	1	0	1	1	1
56	0	1	1	1	0	0	0
57	0	1	1	1	0	0	1
58	0	1	1	1	0	1	0
59	0	1	1	1	0	1	1
60	0	1	1	1	1	0	0
61	0	1	1	1	1	0	1
62	0	1	1	1	1	1	0
63	0	1	1	1	1	1	1
64	1	0	0	0	0	0	0

DECIMAL ADDRESS	PIN 7	PIN 6	PIN 5	PIN 4	PIN 3	PIN 2	PIN 1
81	1	0	1	0	0	0	1
82	1	0	1	0	0	1	0
83	1	0	1	0	0	1	1
84	1	0	1	0	1	0	0
85	1	0	1	0	1	0	1
86	1	0	1	0	1	1	0
87	1	0	1	0	1	1	1
88	1	0	1	1	0	0	0
89	1	0	1	1	0	0	1
90	1	0	1	1	0	1	0
91	1	0	1	1	0	1	1
92	1	0	1	1	1	0	0
93	1	0	1	1	1	0	1
94	1	0	1	1	1	1	0
95	1	0	1	1	1	1	1
96	1	1	0	0	0	0	0

DECIMAL ADDRESS	PIN 7	PIN 6	PIN 5	PIN 4	PIN 3	PIN 2	PIN 1
113	1	1	1	0	0	0	1
114	1	1	1	0	0	1	0
115	1	1	1	0	0	1	1
116	1	1	1	0	1	0	0
117	1	1	1	0	1	0	1
118	1	1	1	0	1	1	0
119	1	1	1	0	1	1	1
120	1	1	1	1	0	0	0
121	1	1	1	1	0	0	1
122	1	1	1	1	0	1	0
123	1	1	1	1	0	1	1
124	1	1	1	1	1	0	0
125	1	1	1	1	1	0	1
126	1	1	1	1	1	1	0
127	1	1	1	1	1	1	1

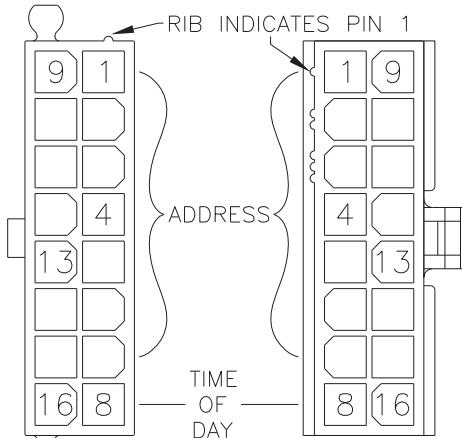

WIRING DIAGRAM
ADDRESS PLUG
WITH ALL WIRES
CONNECTED

1	BRN	9
2	RED	10
3	ORG	11
4	TAN	12
5	PNK	13
6	BLU	14
7	VIO	15
8	BLK	16

TIME OF DAY SWITCH FUNCTION TABLE

ON	T.O.D. ON MAIN CLOCK DIGITS W/O SIGNAL
OFF	DISPLAY WILL BLANK W/O SIGNAL

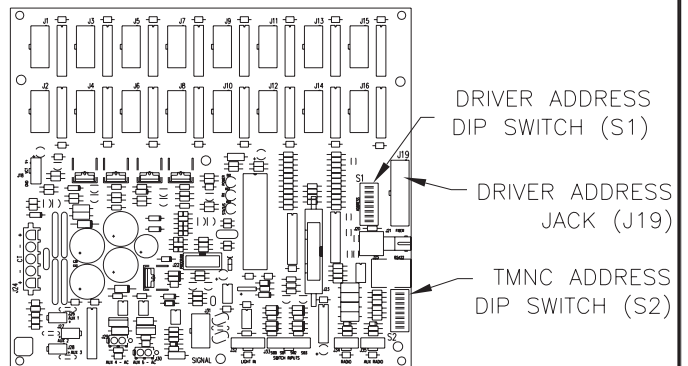

DISPLAY DRIVER
SCALE 1=4

NOTES:

0 = WIRE CONNECTED, 1 = WIRE NOT CONNECTED

REFER TO THE FOLLOWING DRAWINGS FOR ADDITIONAL ADDRESS AND SWITCH SETTINGS:

ADDRESS SWITCH A-284772
TMNC ADD SWITCH A-284773

THE CONCEPTS EXPRESSED AND DETAILS SHOWN ON THIS DRAWING ARE CONFIDENTIAL AND PROPRIETARY. DO NOT REPRODUCE BY ANY MEANS, INCLUDING ELECTRONICALLY WITHOUT THE EXPRESSED WRITTEN CONSENT OF DAKTRONICS, INC. COPYRIGHT 2005 DAKTRONICS, INC.			
DAKTRONICS, INC. BROOKINGS, SD 57006			
PROJ:			
TITLE: ADDRESS TABLE; DRIVER, MCAST, ADDRESS JACK			
DES. BY:		DRAWN BY: DULSCHM	
		DATE: 11 SEP 06	
REVISION	APPR. BY:	1388-R10A-284771	
00	SCALE: 1 = 1		

REV.	DATE	DESCRIPTION	BY	APPR.
------	------	-------------	----	-------

DECIMAL ADDRESS	SWITCH 7	SWITCH 6	SWITCH 5	SWITCH 4	SWITCH 3	SWITCH 2	SWITCH 1
1	0	0	0	0	0	0	1
2	0	0	0	0	0	0	1
3	0	0	0	0	0	0	1
4	0	0	0	0	0	1	0
5	0	0	0	0	0	1	0
6	0	0	0	0	0	1	0
7	0	0	0	0	0	1	1
8	0	0	0	0	1	0	0
9	0	0	0	0	1	0	0
10	0	0	0	1	0	1	0
11	0	0	0	1	0	1	1
12	0	0	0	1	1	0	0
13	0	0	0	1	1	0	1
14	0	0	0	1	1	1	0
15	0	0	0	1	1	1	1
16	0	0	1	0	0	0	0

DECIMAL ADDRESS	SWITCH 7	SWITCH 6	SWITCH 5	SWITCH 4	SWITCH 3	SWITCH 2	SWITCH 1
33	0	1	0	0	0	0	1
34	0	1	0	0	0	0	1
35	0	1	0	0	0	1	1
36	0	1	0	0	1	0	0
37	0	1	0	0	1	0	1
38	0	1	0	0	1	1	0
39	0	1	0	0	1	1	1
40	0	1	0	1	0	0	0
41	0	1	0	1	0	0	1
42	0	1	0	1	0	1	0
43	0	1	0	1	0	1	1
44	0	1	0	1	1	0	0
45	0	1	0	1	1	0	1
46	0	1	0	1	1	1	0
47	0	1	0	1	1	1	1
48	0	1	1	0	0	0	0

DECIMAL ADDRESS	SWITCH 7	SWITCH 6	SWITCH 5	SWITCH 4	SWITCH 3	SWITCH 2	SWITCH 1
65	1	0	0	0	0	0	1
66	1	0	0	0	0	1	0
67	1	0	0	0	0	1	1
68	1	0	0	0	1	0	0
69	1	0	0	0	1	0	1
70	1	0	0	0	1	1	0
71	1	0	0	0	1	1	1
72	1	0	0	1	0	0	0
73	1	0	0	1	0	0	1
74	1	0	0	1	0	1	0
75	1	0	0	1	0	1	1
76	1	0	0	1	1	0	0
77	1	0	0	1	1	0	1
78	1	0	0	1	1	1	0
79	1	0	0	1	1	1	1
80	1	0	1	0	0	0	0

DECIMAL ADDRESS	SWITCH 7	SWITCH 6	SWITCH 5	SWITCH 4	SWITCH 3	SWITCH 2	SWITCH 1
97	1	1	0	0	0	0	1
98	1	1	0	0	0	1	0
99	1	1	0	0	0	1	1
100	1	1	0	0	1	0	0
101	1	1	0	0	1	0	1
102	1	1	0	0	1	1	0
103	1	1	0	0	1	1	1
104	1	1	0	1	0	0	0
105	1	1	0	1	0	0	1
106	1	1	0	1	0	1	0
107	1	1	0	1	0	1	1
108	1	1	0	1	1	0	0
109	1	1	0	1	1	0	1
110	1	1	0	1	1	1	0
111	1	1	0	1	1	1	1
112	1	1	1	0	0	0	0

DECIMAL ADDRESS	SWITCH 7	SWITCH 6	SWITCH 5	SWITCH 4	SWITCH 3	SWITCH 2	SWITCH 1
17	0	0	1	0	0	0	1
18	0	0	1	0	0	0	1
19	0	0	1	0	0	1	1
20	0	0	1	0	1	0	0
21	0	0	1	0	1	0	1
22	0	0	1	0	1	1	0
23	0	0	1	0	1	1	1
24	0	0	1	1	0	0	0
25	0	0	1	1	0	0	1
26	0	0	1	1	0	1	0
27	0	0	1	1	0	1	1
28	0	0	1	1	1	0	0
29	0	0	1	1	1	0	1
30	0	0	1	1	1	1	0
31	0	0	1	1	1	1	1
32	0	1	0	0	0	0	0

DECIMAL ADDRESS	SWITCH 7	SWITCH 6	SWITCH 5	SWITCH 4	SWITCH 3	SWITCH 2	SWITCH 1
49	0	1	1	0	0	0	1
50	0	1	1	0	0	0	1
51	0	1	1	0	0	1	1
52	0	1	1	0	1	0	0
53	0	1	1	0	1	0	1
54	0	1	1	0	1	1	0
55	0	1	1	0	1	1	1
56	0	1	1	1	0	0	0
57	0	1	1	1	0	0	1
58	0	1	1	1	0	1	0
59	0	1	1	1	0	1	1
60	0	1	1	1	1	0	0
61	0	1	1	1	1	0	1
62	0	1	1	1	1	1	0
63	0	1	1	1	1	1	1
64	1	0	0	0	0	0	0

DECIMAL ADDRESS	SWITCH 7	SWITCH 6	SWITCH 5	SWITCH 4	SWITCH 3	SWITCH 2	SWITCH 1
81	1	0	1	0	0	0	1
82	1	0	1	0	0	1	0
83	1	0	1	0	0	1	1
84	1	0	1	0	1	0	0
85	1	0	1	0	1	0	1
86	1	0	1	0	1	1	0
87	1	0	1	0	1	1	1
88	1	0	1	1	0	0	0
89	1	0	1	1	0	0	1
90	1	0	1	1	0	1	0
91	1	0	1	1	0	1	1
92	1	0	1	1	1	0	0
93	1	0	1	1	1	0	1
94	1	0	1	1	1	1	0
95	1	0	1	1	1	1	1
96	1	1	0	0	0	0	0

DECIMAL ADDRESS	SWITCH 7	SWITCH 6	SWITCH 5	SWITCH 4	SWITCH 3	SWITCH 2	SWITCH 1
113	1	1	1	0	0	0	1
114	1	1	1	0	0	1	0
115	1	1	1	0	0	1	1
116	1	1	1	0	1	0	0
117	1	1	1	0	1	0	1
118	1	1	1	0	1	1	0
119	1	1	1	0	1	1	1
120	1	1	1	1	0	0	0
121	1	1	1	1	0	0	1
122	1	1	1	1	0	1	0
123	1	1	1	1	0	1	1
124	1	1	1	1	1	0	0
125	1	1	1	1	1	0	1
126	1	1	1	1	1	1	0
127	1	1	1	1	1	1	1

TIME OF DAY SWITCH FUNCTION TABLE

ON	TOD ON MAIN CLOCK DIGITS W/O SIGNAL
OFF	DISPLAY WILL BLANK W/O SIGNAL

S1—ADDRESS DIP SWITCH
SCALE 2=1

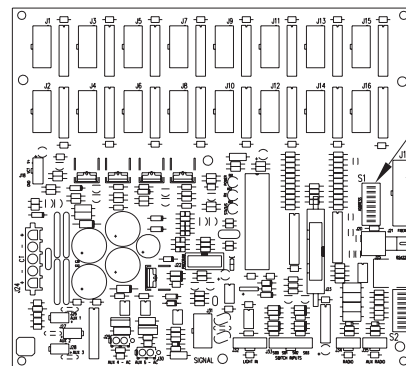
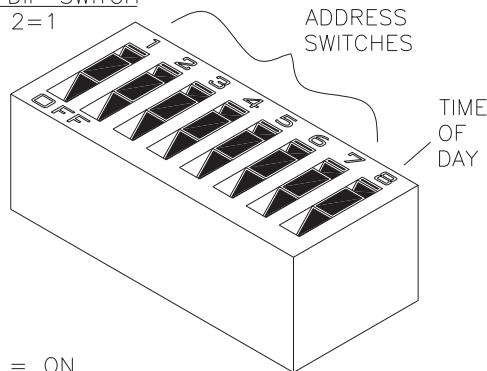

DISPLAY DRIVER
SCALE 1=4

NOTES:

0 = OFF, 1 = ON

REFER TO THE FOLLOWING DRAWINGS FOR
ADDITIONAL ADDRESS AND SWITCH SETTINGS:
ADDRESS JACK A-284771
TMNC ADD SWITCH A-284773

THE CONCEPTS EXPRESSED AND DETAILS SHOWN ON THIS DRAWING ARE CONFIDENTIAL AND PROPRIETARY. DO NOT REPRODUCE BY ANY MEANS, INCLUDING ELECTRONICALLY WITHOUT THE EXPRESSED WRITTEN CONSENT OF DAKTRONICS, INC. COPYRIGHT 2005 DAKTRONICS, INC.

DAKTRONICS, INC. BROOKINGS, SD 57006

PROJ:

TITLE: ADDRESS TABLE; DRIVER, MCAST, ADD DIP SWITCH

DES. BY:

DRAWN BY: DULSCHM

DATE: 11 SEP 06

REVISION

APPR. BY:

00

SCALE: 1 = 1

1388-R10B-284772

REV.	DATE	DESCRIPTION	BY	APPR.
------	------	-------------	----	-------

TYPICAL TNMC FUNCTIONS

ALL OFF = 221

	SWITCH 4	SWITCH 3	SWITCH 2	SWITCH 1	
(222)	1	0	0	0	1
(223)	2	0	0	1	0
(224)	3	0	0	1	1
(225)	4	0	1	0	0
	5	0	1	0	1
	6	0	1	1	0
	7	0	1	1	1
	8	1	0	0	0
	9	1	0	0	1
	10	1	0	1	0
	11	1	0	1	1
	12	1	1	0	0
	13	1	1	0	1
	14	1	1	1	0
	15	1	1	1	1
	16	0	0	0	0

	SWITCH 4	SWITCH 3	SWITCH 2	SWITCH 1	
	33	0	0	0	1
	34	0	0	1	0
	35	0	0	1	1
	36	0	1	0	0
	37	0	1	0	1
	38	0	1	1	0
	39	0	1	1	1
	40	1	0	0	0
	41	1	0	0	1
	42	1	0	1	0
	43	1	0	1	1
	44	1	1	0	0
	45	1	1	0	1
	46	1	1	1	0
	47	1	1	1	1
	48	0	0	0	0

	SWITCH 4	SWITCH 3	SWITCH 2	SWITCH 1	
	17	0	0	0	1
	18	0	0	1	0
	19	0	0	1	1
	20	0	1	0	0
	21	0	1	0	1
	22	0	1	1	0
	23	0	1	1	1
	24	1	0	0	0
	25	1	0	0	1
	26	1	0	1	0
	27	1	0	1	1
	28	1	1	0	0
	29	1	1	0	1
	30	1	1	1	0
	31	1	1	1	1
	32	0	0	0	0

	SWITCH 4	SWITCH 3	SWITCH 2	SWITCH 1	
	49	0	0	0	1
	50	0	0	1	0
	51	0	0	1	1
	52	0	1	0	0
	53	0	1	0	1
	54	0	1	1	0
	55	0	1	1	1
	56	1	0	0	0
	57	1	0	0	1
	58	1	0	1	0
	59	1	0	1	1
	60	1	1	0	0
	61	1	1	0	1
	62	1	1	1	0
	63	1	1	1	1

GUEST SELECT SWITCH FUNCTION TABLE

ON	GUEST DATA SENT TO FIRST DISPLAY
OFF	HOME DATA SENT TO FIRST DISPLAY

SPARE 1	RESERVED FOR FUTURE USE
SPARE 2	RESERVED FOR FUTURE USE
SPARE 3	RESERVED FOR FUTURE USE

S2- TNMC ADDRESS
DIP SWITCH
SCALE 2=1

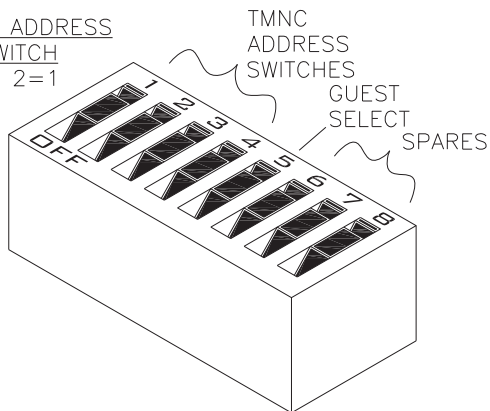

NOTES:

0 = OFF, 1 = ON

REFER TO THE FOLLOWING DRAWINGS FOR
ADDITIONAL ADDRESS AND SWITCH SETTINGS:
ADDRESS JACK A-284771
ADDRESS SWITCH A-284772

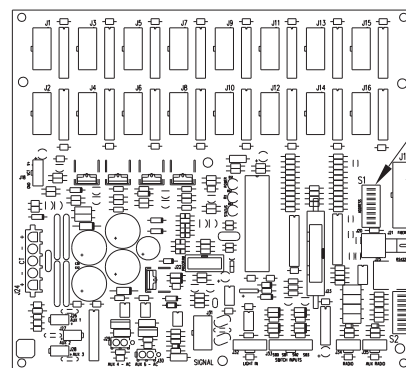

DISPLAY DRIVER
SCALE 1=4

THE CONCEPTS EXPRESSED AND DETAILS SHOWN ON THIS DRAWING ARE CONFIDENTIAL AND PROPRIETARY. DO NOT REPRODUCE BY ANY MEANS, INCLUDING ELECTRONICALLY WITHOUT THE EXPRESSED WRITTEN CONSENT OF DAKTRONICS, INC. COPYRIGHT 2005 DAKTRONICS, INC.			
DAKTRONICS, INC. BROOKINGS, SD 57006			
PROJ:			
TITLE: ADDRESS TABLE: DRIVER- MCAST- TNMC DIP SWITCH			
DES. BY:		DRAWN BY: DULSCHM	
		DATE: 11 SEP 06	
REVISION	APPR. BY:	1388-R10A-284773	
01	SCALE: 1 = 1		

01	15 FEB 08	ADDED TYPICAL TNMC FUNCTIONS	DS	
REV.	DATE	DESCRIPTION	BY	APPR.

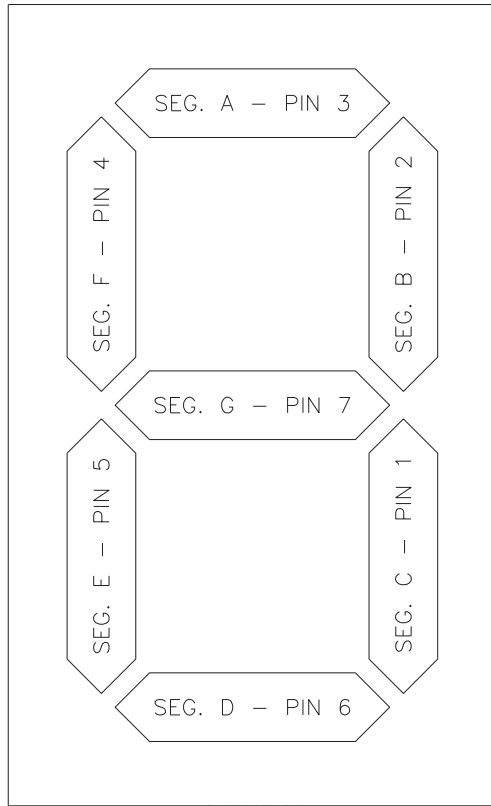

7 SEGMENT DIGIT
FRONT VIEW

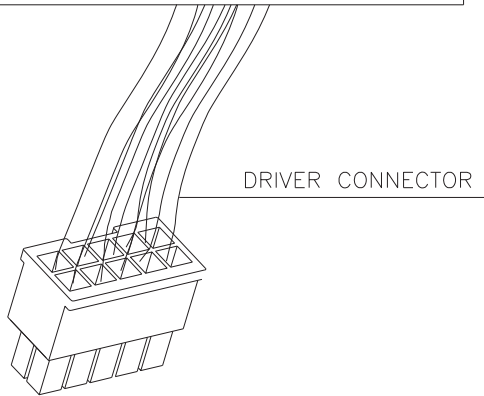

DRIVER CONNECTOR

COLOR CODE		
PIN NO.	WIRE COLOR	DRIVER SEGMENT
1	ORN	C
2	RED	B
3	BRN	A
4	BLU	F
5	WHT	E
6	GRN	D
7	BLK	G
8	GRY	H
9	VIO	VR+
10	YEL	VG+

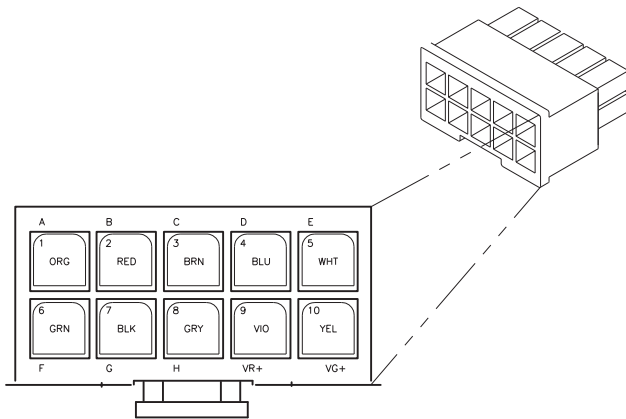

NOTE: "H" SEGMENT, GRAY WIRE IS NOT USED ON 7 SEGMENT DIGIT.

THE CONCEPTS EXPRESSED AND DETAILS SHOWN ON THIS DRAWING ARE CONFIDENTIAL AND PROPRIETARY. DO NOT REPRODUCE BY ANY MEANS, INCLUDING ELECTRONICALLY WITHOUT THE EXPRESSED WRITTEN CONSENT OF DAKTRONICS, INC. COPYRIGHT 2007 DAKTRONICS, INC.

DAKTRONICS, INC. BROOKINGS, SD 57006

PROJ: COLORSMART

TITLE: SEGMENTATION, COLOR OR MONO 7 SEGMENT DIGIT

DES. BY: MMILLER DRAWN BY: JHELMS DATE: 07 JUN 07

REVISION	APPR. BY:	1388-R04A-308053
00	SCALE: 1=4	

REV.	DATE	DESCRIPTION	BY	APPR.

Appendix F: Daktronics Warranty and Limitation of Liability

**DAKTRONICS
WARRANTY AND LIMITATION OF LIABILITY**

This Warranty and Limitation of Liability (the "Warranty") sets forth the warranty provided by Daktronics with respect to the Equipment. By accepting delivery of the Equipment, Purchaser agrees to be bound by and accept these terms and conditions. All defined terms within the Warranty shall have the same meaning and definition as provided elsewhere in the Agreement.

DAKTRONICS WILL ONLY BE OBLIGATED TO HONOR THE WARRANTY SET FORTH IN THESE TERMS AND CONDITIONS UPON RECEIPT OF FULL PAYMENT FOR THE EQUIPMENT.

1. Warranty Coverage

A. Daktronics warrants to the original end-user that the Equipment will be free from Defects (as defined below) in materials and workmanship for a period of one (1) year (the "Warranty Period"). The warranty period shall commence on the earlier of: (i) four weeks from the date that the equipment leaves Daktronics' facility; or (ii) Substantial Completion as defined herein. The warranty period shall expire on the first anniversary of the commencement date.

"Substantial Completion" means the operational availability of the Equipment to the Purchaser in accordance with the Equipment's specifications, without regard to punch-list items, or other non-substantial items which do not affect the operation of the Equipment.

B. Daktronics' obligation under this Warranty is limited to, at Daktronics' option, replacing or repairing, any Equipment or part thereof that is found by Daktronics not to conform to the Equipment's specifications. Unless otherwise directed by Daktronics, any defective part or component shall be returned to Daktronics for repair or replacement. Daktronics may, at its option, provide on-site warranty service. Daktronics shall have a reasonable period of time to make such replacements or repairs and all labor associated therewith shall be performed during regular working hours. Regular working hours are Monday through Friday between 8:00 a.m. and 5:00 p.m. at the location where labor is performed, excluding any holidays observed by either Purchaser or Daktronics.

C. Daktronics shall pay ground transportation charges for the return of any defective component of the Equipment. If returned Equipment is repaired or replaced under the terms of this warranty, Daktronics will prepay ground transportation charges back to Purchaser; otherwise, Purchaser shall pay transportation charges to return the Equipment back to the Purchaser. All returns must be pre-approved by Daktronics before shipment. Daktronics shall not be obligated to pay freight for any unapproved return. Purchaser shall pay any upgraded or expedited transportation charges.

D. Any replacement parts or Equipment will be new or serviceably used, comparable in function and performance to the original part or Equipment, and warranted for the remainder of the Warranty Period. Purchasing additional parts or Equipment from the Seller does not extend this Warranty Period.

E. Defects shall be defined as follows. With regard to the Equipment (excepting LEDs), a "Defect" shall refer to a material variance from the design specifications that prohibit the Equipment from operating for its intended use. With respect to LEDs, "Defects" are defined as LED pixels that cease to emit light. The limited warranty provided by Daktronics does not impose any duty or liability upon Daktronics for partial LED pixel degradation. Nor does the limited warranty provide for the replacement or installation of communication methods including but not limited to, wire, fiber optic cable, conduit, trenching, or for the purpose of overcoming local site interference radio equipment substitutions.

THIS LIMITED WARRANTY IS THE ONLY WARRANTY APPLICABLE TO THE EQUIPMENT AND REPLACES ALL OTHER WARRANTIES OR CONDITIONS, EXPRESS OR IMPLIED, INCLUDING, BUT NOT LIMITED TO, THE IMPLIED WARRANTIES OR CONDITIONS OF MERCHANTABILITY AND FITNESS FOR A PARTICULAR PURPOSE. SPECIFICALLY, EXCEPT AS PROVIDED HEREIN, THE SELLER UNDERTAKES NO RESPONSIBILITY FOR THE QUALITY OF THE EQUIPMENT OR THAT THE EQUIPMENT WILL BE FIT FOR ANY PARTICULAR PURPOSE FOR WHICH PURCHASER MAY BE BUYING THE EQUIPMENT. ANY IMPLIED WARRANTY IS LIMITED IN DURATION TO THE WARRANTY PERIOD. NO ORAL OR WRITTEN INFORMATION, OR ADVICE GIVEN BY THE COMPANY, ITS AGENTS OR EMPLOYEES, SHALL CREATE A WARRANTY OR IN ANY WAY INCREASE THE SCOPE OF THIS LIMITED WARRANTY.

THIS LIMITED WARRANTY IS NOT TRANSFERABLE.

2. Exclusion from Warranty Coverage

The limited warranty provided by Daktronics does not impose any duty or liability upon Daktronics for:

A. Any damage occurring, at any time, during shipment of Equipment unless otherwise provided for in the Agreement. When returning Equipment to Daktronics for repair or replacement, Purchaser assumes all risk of loss or damage, and agrees to use any shipping containers that might be provided by Daktronics and to ship the Equipment in the manner prescribed by Daktronics;

B. Any damage caused by the unauthorized adjustment, repair or service of the Equipment by anyone other than personnel of Daktronics or its authorized repair agents;



C. Damage caused by the failure to provide a continuously suitable environment, including, but not limited to: (i) neglect or misuse, (ii) a failure or sudden surge of electrical power, (iii) improper air conditioning or humidity control, or (iv) any other cause other than ordinary use;

D. Damage caused by fire, flood, earthquake, water, wind, lightning or other natural disaster, strike, inability to obtain materials or utilities, war, terrorism, civil disturbance or any other cause beyond Daktronics' reasonable control;

E. Failure to adjust, repair or replace any item of Equipment if it would be impractical for Daktronics personnel to do so because of connection of the Equipment by mechanical or electrical means to another device not supplied by Daktronics, or the existence of general environmental conditions at the site that pose a danger to Daktronics personnel;

F. Any statements made about the product by salesmen, dealers, distributors or agents, unless such statements are in a written document signed by an officer of Daktronics. Such statements as are not included in a signed writing do not constitute warranties, shall not be relied upon by Purchaser and are not part of the contract of sale;

G. Any damage arising from the use of Daktronics products in any application other than the commercial and industrial applications for which they are intended, unless, upon request, such use is specifically approved in writing by Daktronics; or

H. Any performance of preventive maintenance.

3. **Limitation of Liability**

Daktronics shall be under no obligation to furnish continued service under this Warranty if alterations are made to the Equipment without the prior written approval of Daktronics.

It is specifically agreed that the price of the Equipment is based upon the following limitation of liability. In no event shall Daktronics (including its subsidiaries, affiliates, officers, directors, employees, or agents) be liable for any special, consequential, incidental or exemplary damages arising out of or in any way connected with the Equipment or otherwise, including but not limited to damages for lost profits, cost of substitute or replacement equipment, down time, lost data, injury to property or any damages or sums paid by Purchaser to third parties, even if Daktronics has been advised of the possibility of such damages. The foregoing limitation of liability shall apply whether any claim is based upon principles of contract, tort or statutory duty, principles of indemnity or contribution, or otherwise.

In no event shall Daktronics be liable to Purchaser or any other party for loss, damage, or injury of any kind or nature arising out of or in connection with this Warranty in excess of the purchase price of the Equipment actually delivered to and paid for by the Purchaser. The Purchaser's remedy in any dispute under this Warranty shall be ultimately limited to the Purchase Price of the Equipment to the extent the Purchase Price has been paid.

4. **Assignment of Rights**

The Warranty contained herein extends only to the original end-user (which may be the Purchaser) of the Equipment and no attempt to extend the Warranty to any subsequent user-transferee of the Equipment shall be valid or enforceable without the express written consent of Daktronics.

5. **Dispute Resolution**

Any dispute between the parties will be resolved exclusively and finally by arbitration administered by the American Arbitration Association ("AAA") and conducted under its rules, except as otherwise provided below. The arbitration will be conducted before a single arbitrator. The arbitration shall be held in Brookings, South Dakota. Any decision rendered in such arbitration proceedings will be final and binding on each of the parties, and judgment may be entered thereon in any court of competent jurisdiction. This arbitration agreement is made pursuant to a transaction involving interstate commerce, and shall be governed by the Federal Arbitration Act.

6. **Governing Law**

The rights and obligations of the parties under this warranty shall not be governed by the provisions of the United Nations Convention on Contracts for the International Sales of Goods of 1980. Both parties consent to the application of the laws of the State of South Dakota to govern, interpret, and enforce all of Purchaser and Daktronics rights, duties, and obligations arising from, or relating in any manner to, the subject matter of this Warranty, without regard to conflict of law principles.

7. **Availability of Extended Service Agreement**

For Purchaser's protection, in addition to that afforded by the warranties set forth herein, Purchaser may purchase extended warranty services to cover the Equipment. The Extended Service Agreement, available from Daktronics, provides for electronic parts repair and/or on-site labor for an extended period from the date of expiration of this warranty. Alternatively, an Extended Service Agreement may be purchased in conjunction with this warranty for extended additional services. For further information, contact Daktronics Customer Service at 1-800-DAKTRONics (1-800-325-8766).