

**INSTALLATION, OPERATION  
MAINTENANCE MANUAL**

**CHRONDEK C-33**

**Drag Race Timer  
and Accessories**

Copyright 1994 Chrondek, Inc.

Chrondek, Inc.  
331 32nd Avenue  
P.O. Box 586  
Brookings, South Dakota 57006  
Phone: (605) 697-4363 or 1-800-854-6556



# TABLE OF CONTENTS

1.	INTRODUCTION.....	1
2.	NEW TRACK INSTALLATION.....	2
2.1	UNPACKING/DAMAGE INFORMATION.....	2
2.1.1	REPLACEMENT PROCEDURE.....	2
2.1.2	PACKAGING FOR RETURN.....	2
2.1.3	WHERE TO SEND.....	2
2.1.4	WARRANTY.....	2
2.2	PARTS IDENTIFICATION.....	3
2.3	SYSTEM DIAGRAMS.....	3
2.4	LOCATION REQUIREMENTS.....	7
2.4.1	SIGNAL CONDUIT AND CABLE.....	7
2.4.2	POWER.....	7
2.4.3	ELECTRICAL.....	7
2.4.3.1	NOISE (RADIO/PA).....	8
2.4.3.2	GROUNDING.....	8
2.4.3.3	ISOLATED POWER CIRCUITS.....	8
2.4.3.4	ELECTRICAL CODE.....	8
2.5	MOUNTING AND LOCATING EQUIPMENT.....	9
2.5.1	MOUNTING AND SPEED TRAP DISTANCES.....	9
2.5.2	PHOTOCELLS.....	10
2.5.3	ADAPTING 3 POSITION TO 2 POSITION MOUNTING.....	10
2.5.4	TREE MOUNTING CONSIDERATIONS.....	12
2.5.5	E.T. AND LOGGING PRINTER MOUNTING.....	12
2.5.6	START LINE ELECTRONICS BOX MOUNTING.....	12
2.5.7	FINISH LINE ELECTRONICS BOX MOUNTING.....	12
2.6	FIELD WIRING.....	13
2.6.1	START LINE WIRING.....	13
2.6.1.1	TOWER JUNCTION BOX.....	13
2.6.1.2	TOWER JUNCTION BOX TO START LINE JUNCTION BOX WIRING.....	13
2.6.2	START LINE ELECTRONICS BOX (SLEB).....	16
2.6.3	START LINE PHOTOCELLS.....	16
2.6.4	START LINE LIGHT SOURCES.....	16
2.6.5	GUARD BEAM INSTALLATION (OPTIONAL).....	19
2.6.6	INSTALLATION OF 3-AMBER TREE.....	19
2.6.7	INTERMEDIATE WIRING (OPTIONAL).....	19
2.6.7.1	INTERMEDIATE PHOTOCELLS AND LIGHT SOURCES.....	21
2.6.7.2	INTERMEDIATE TRANSFORMER.....	23

TABLE OF CONTENTS (CONTINUED)

- 2.6.8 FINISH LINE WIRING..... 23
  - 2.6.8.1 FINISH LINE JUNCTION BOX WIRING..... 23
    - TRUE WIN CAPABILITY..... 30
  - 2.6.8.2 FINISH LINE ELECTRONICS BOX..... 25
  - 2.6.8.3 FINISH LINE TRANSFORMER..... 29
  - 2.6.8.4 TIME SLIP PRINTER WIRING..... 29
  - 2.6.8.5 OPTIONAL: JUDGE SYSTEM WIRING FOR TRUE WIN CAPABILITY..... 30
  - 2.6.8.6 OPTIONAL: JUDGE SYSTEM WIRING FOR FIRST TO FINISH..... 30
  - 2.6.8.7 OPTIONAL: WIRING BETWEEN THE SCOREBOARD INTERFACE AND THE RIGHT SCOREBOARD..... 32
  - 2.6.8.8 OPTIONAL: WIRING BETWEEN THE SCOREBOARD INTERFACE AND THE LEFT SCOREBOARD..... 32
- 2.7 OPERATIONAL CHECK..... 33
  - 2.7.1 TIMER - MONITOR - KEYBOARD..... 33
  - 2.7.2 TIMER - START LINE - EMERGENCY..... 34
  - 2.7.3 START LINE PHOTOCELL CHECK (USING BUILT-IN C-33 FUNCTION)..... 34
  - 2.7.4 TIMER - INTERMEDIATE PHOTOCELL CHECK..... 35
  - 2.7.5 TIMER - FINISH LINE - WIN LIGHTS..... 35
  - 2.7.6 FINISH LINE PHOTOCELL CHECK..... 35
  - 2.7.7 PRINTERS..... 35
  - 2.7.8 SCOREBOARDS (OPTIONAL) (BUILT-IN C-33 FUNCTION)..... 36
  - 2.7.9 FINAL TESTING..... 36
- 2.8 TRACK WITH EXISTING SYSTEM..... 36
  - 2.8.1 CONNECTOR SET TO TIE NEW SYSTEM TO OLD SYSTEM CABLE..... 36
  - 2.8.2 NEW EQUIPMENT..... 36
- 2.9 SIGHTING THE PHOTOCELLS..... 37
- 3. OPERATION OF THE C-33 RACE TIMER..... 39
  - 3.1 GENERAL OPERATION..... 39
    - 3.1.1 ENTERING DIAL-INS..... 39
  - 3.2 C-33 RACE CONTROLLER FUNCTIONS..... 41
    - 3.2.1 POWER BUTTON..... 41
    - 3.2.2 TIMERS RESET..... 42
    - 3.2.3 TREE COUNTDOWN MODES..... 42
    - 3.2.4 SURE START..... 42
    - 3.2.5 TRUE WIN/BREAKOUT..... 42
    - 3.2.6 EMERGENCY..... 44



TABLE OF CONTENTS (CONTINUED)

3.2.7	ALTITUDE ADJUSTMENT.....	44
3.2.7.1	AN INTRODUCTION TO ALTITUDE ADJUSTMENT.....	44
3.2.7.2	ALTITUDE ADJUSTMENT EXAMPLE.....	46
3.2.7.3	USING ALTITUDE ADJUSTMENT.....	51
3.2.7.4	USING DIAL-INS WITH ADJUSTMENT FACTORS.....	51
3.2.8	REACTION TIMER.....	51
3.2.9	PRINTERS.....	52
3.2.10	RESET WIN LIGHT.....	52
3.2.11	PHOTOCELL CHECK.....	52
3.3	ADDITIONAL FUNCTIONS.....	53
3.3.1	HELP SCREEN.....	53
3.3.1.1	DEFAULT VALUES.....	54
3.3.2	SETUP PARAMETERS MENU.....	54
3.3.2.1	(A) ALTITUDE ADJUSTMENT FACTORS.....	54
3.3.2.2	(C) TREE COUNTDOWN MODES.....	55
3.3.2.3	(D) FINISH LINE DISTANCE.....	56
3.3.2.4	(E) EVENT AND SPONSOR INFORMATION.....	56
3.3.2.5	(F) TIME SLIP FORMAT.....	56
3.3.2.6	(S) SET SCOREBOARD ENABLES.....	58
3.3.2.7	(T) SYSTEM TIME AND DATE.....	58
3.3.2.8	(W) WIN LIGHT FORMAT.....	59
3.3.2.9	(CTRL-S) SCOREBOARD DIAGNOSTICS.....	59
3.3.2.10	(CTRL-W) WIN LIGHT DIAGNOSTICS.....	59
3.3.2.11	(CTRL-R) SOFT RESET FUNCTION.....	59
3.3.3	RACE OPERATION.....	60
3.3.4	INFRACTIONS.....	60
3.3.5	GUARD BEAM OPTION USE.....	60
3.3.6	OPTIONAL JUDGE SYSTEM.....	61
3.3.7	SCOREBOARD OUTPUT OPTION.....	61
3.3.8	RESULTS SYSTEM (CARS).....	61
4.	TROUBLESHOOTING/MAINTENANCE.....	62
4.1	TROUBLESHOOTING YOUR SYSTEM.....	62
4.2	MAINTENANCE.....	63

TABLE OF CONTENTS (CONTINUED)

4.3	REPLACEMENT PARTS.....	64
4.4	INTERNAL DIP-SWITCH SETTINGS ON THE I/O BOARD....	68

APPENDIX

A.1	LIST OF FIGURES.....	73
A.2	LIST OF DATA TABLES.....	74
A.3	INFRARED PHOTOCELLS.....	75

# 1. INTRODUCTION

The **Chrondek C-33 Timer** system utilizes the latest in microprocessor technology and is designed and manufactured for reliability, easy service, and long use.

This manual is provided to assist the user in operating the system. If there are any questions regarding the safety, installation, or operation of this system, or if the system needs service, feel free to call. Our phone number is 605/697-4363; or call toll free 800/854-6556.

This manual will cover all aspects of use of the C-33 timer, from installation of the track equipment, to operation of the timer itself, to troubleshooting. Follow all instructions as given in the text. All instructions are given in a logical order for best installation and operation.

## **IMPORTANT SAFEGUARDS**

1. Read and understand installation instructions before installing.
2. Do not drop the control console or allow it to get wet.
3. Opening or disassembly of equipment by non-qualified personnel can void the warranty.
4. Do not disassemble the control console or the electronic controls of the display unless you are qualified to do so and there is need for equipment to be installed or serviced or the warranty will be void.
5. **DISCONNECT POWER FROM THE UNIT WHEN NOT IN USE, OR WHEN SERVICING.**
6. **DISCONNECT CABLE FROM THE BACK OF THE C-33 RACE CONTROLLER AT THE END OF THE DAY OR WHEN LIGHTNING IS OCCURRING IN THE AREA.**

## **2. NEW TRACK INSTALLATION**

### **2.1 UNPACKING/DAMAGE INFORMATION**

Open all packages and inspect for shipping damage such as rattles or dents. See that all equipment is included as shown on packing slip. Report any deficiencies immediately to Chrondek, Inc. Save all packing for shipping if warranty repair or exchanging is needed. Shipping packages also work well for off season equipment storage.

#### **2.1.1 REPLACEMENT PROCEDURE**

Chrondeks' unique exchange program was designed with the customers' needs in mind. This is the quickest and most economical way available for product repair. If a component has failed or is damaged during shipping, Chrondek will send the customer a replacement within 24 hours under normal circumstances. The customer in turn sends the failed components to Chrondek. This not only saves the customer money but the downtime of the product is minimal. In urgent situations every attempt is made to ship by the fastest transit method available.

#### **2.1.2 PACKAGING FOR RETURN**

If possible, return the component to Chrondek in the original packing material. Please enclose your name and address with symptoms described in detail.

#### **2.1.3 WHERE TO SEND**

To return parts or for service assistance contact:

Mail Chrondek, Inc.  
331 32nd Ave.  
P.O. Box 586  
Brookings, South Dakota 57006

Toll Free = 1-800-854-6556  
Phone = 1-605-697-4363

#### **2.1.4 WARRANTY**

Chrondek has a one year warranty on all equipment. Chrondek reserves the option to decide what damage will be covered by the warranty. The owner has the responsibility of paying for postage both to and from Chrondek.

## 2.2 PARTS IDENTIFICATION

Identify each component of the system by using the illustrations throughout this manual. A list of figures appears in Appendix Section A.1. Once all parts have been identified, group the parts into logical groups for assembly. Group all the equipment into separate groups such as: equipment used in the tower, all equipment for the start line, intermediate parts of the track, and finish line. This will organize the installation procedure so unnecessary trips down the track are avoided.

## 2.3 SYSTEM DIAGRAMS

These diagrams show the complete system diagram for a new track setup. Refer to these drawings when installing the system. Some tracks may have some variations on this diagram (i.e. more cable, no guard beam etc.) but basically all tracks will have this configuration. Note: refer to this diagram for details on conduit sizes, cable lengths and type, as well as equipment locations when installing the system. In addition, these diagrams can aid in removal in the off season, emergency replacement, maintenance, safety, and security.

### Part Number Legend for Figure 1.0

<u>Item</u>	<u>Part No.</u>	<u>Item</u>	<u>Part No.</u>
1	A-1067-2	26	A-1067-19
2	A-1173	27	A-1067-20
3	A-1174	28	A-1067-21
4	EN-1218	29	A-1067-22
5	A-1067-3	30	A-1067-36
6	A-1067-4	31	A-1067-74
7	A-1044-7	32	W-1103
8	A-1067-6	33	W-1007
9	A-1067-41	34	W-1007
10	A-1067-26	35	A-1067-25
11	A-1067-40	36	A-1067-26
12	A-1067-3	37	A-1067-27
13	A-1067-7	38	W-1231
14	W-1117	39	A-1169
15	A-1067-8	40	A-1067-31
16	A-1067-9	41	A-1144
17	W-1213	42	A-1169
18	A-1067-10	43	A-1067-3
19	A-1067-11	44	A-1081-16
20	A-1067-12	45	W-1103
21	A-1067-13	46	A-1033-42
22	A-1067-15		
23	A-1067-16		
24	A-1067-17		
25	A-1067-18		

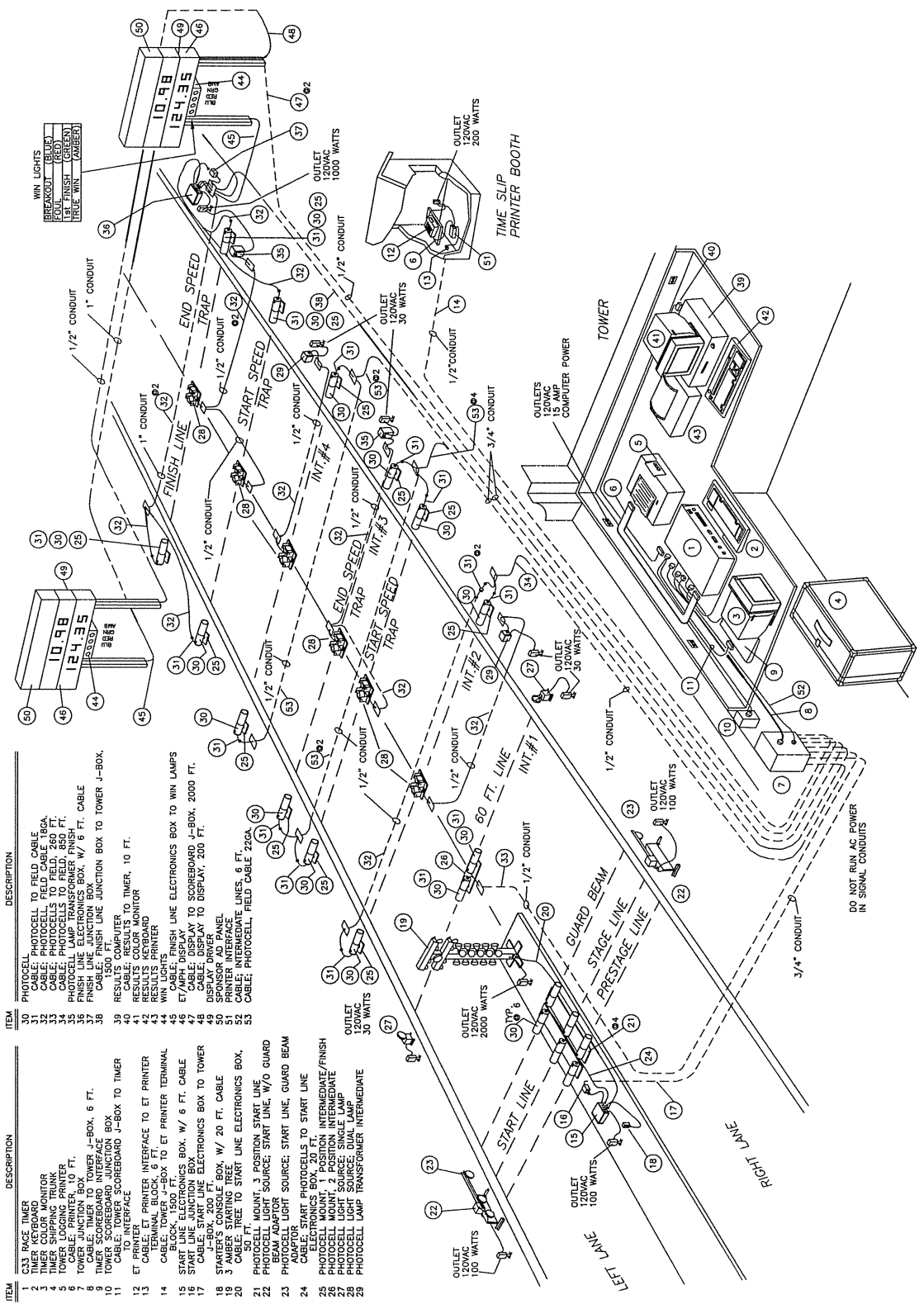

ITEM	DESCRIPTION	DESCRIPTION
1	C33 RACE TIMER	PHOTOCELL
2	TIMER KEYBOARD	CABLE; PHOTOCELL TO FIELD CABLE
3	TIMER COLOR MONITOR	CABLE; PHOTOCELL TO FIELD CABLE, 18GA.
4	TOWER LOGGING PRINTER	CABLE; PHOTOCELLS TO FIELD, 200 FT.
5	TOWER LOGGING PRINTER	CABLE; PHOTOCELLS TO FIELD, 200 FT.
6	CABLE; PRINTER, 10 FT.	PHOTOCELL LAMP TRANSFORMER FINISH
7	TOWER JUNCTION BOX TOWER J-BOX, 6 FT.	FINISH LINE ELECTRONICS BOX, W/ 6 FT. CABLE
8	TOWER SCOREBOARD INTERFACE	FINISH LINE JUNCTION BOX TO TOWER J-BOX.
9	TOWER SCOREBOARD INTERFACE	CABLE; 1500 FT.
10	TOWER SCOREBOARD JUNCTION BOX	CABLE; ROUTERS TO TIMER, 10 FT.
11	C33 INTERFACE	CABLE; RESULTS COLOR MONITOR
12	ET PRINTER	CABLE; RESULTS REMINDER
13	CABLE; ET PRINTER INTERFACE TO ET PRINTER	WIN LIGHTS
14	BLOCK, 1500 FT. BOX TO ET PRINTER TERMINAL	CABLE; FINISH LINE ELECTRONICS BOX TO WIN LAMPS
15	START LINE JUNCTION BOX, W/ 6 FT. CABLE	ET LAMP; DISPLAY TO SCOREBOARD J-BOX, 2000 FT.
16	CABLE; START LINE ELECTRONICS BOX TO TOWER	CABLE; DISPLAY TO DISPLAY, 200 FT.
17	START LINE JUNCTION BOX	INTERMEDIATE LINES, 6 FT. 22GA.
18	STARTERS' CONSOLE BOX, W/ 20 FT. CABLE	CABLE; INTERMEDIATE LINES, 6 FT. 22GA.
19	3 AMBER STARTING TREE	CABLE; PHOTOCELL, FIELD CABLE 22GA.
20	CABLE; TREE TO START LINE ELECTRONICS BOX	
21	PHOTOCELL MOUNT, 3 POSITION START LINE	
22	PHOTOCELL LIGHT SOURCE; START LINE, W/O GUARD	
23	PHOTOCELL LIGHT SOURCE; START LINE, GUARD BEAM ADAPTOR	
24	CABLE; START PHOTOCELLS TO START LINE	
25	PHOTOCELL MOUNT, 1 POSITION INTERMEDIATE/FINISH	
26	PHOTOCELL MOUNT, 2 POSITION INTERMEDIATE	
27	PHOTOCELL LIGHT SOURCE; SINGLE LAMP	
28	PHOTOCELL LIGHT SOURCE; SINGLE LAMP	
29	PHOTOCELL LAMP TRANSFORMER INTERMEDIATE	

FIGURE 1.0

C33 SYSTEM CABLING DIAGRAM

ITEM	DESCRIPTION
6	TOWER JUNCTION BOX, TOWER J-BOX, 6 FT.
7	CABLE: TOWER JUNCTION BOX TO TOWER, 1500 FT.
10	TOWER SCOREBOARD JUNCTION BOX, 6 FT.
11	CABLE: TOWER SCOREBOARD J-BOX TO TIMER TO INTERFACE
12	ET PRINTER
13	CABLE: PRINTER INTERFACE TO ET PRINTER TERMINAL BLOCK, 6 FT.
14	CABLE: TOWER J-BOX TO ET PRINTER TERMINAL BLOCK, 1500 FT.
15	START LINE ELECTRONICS BOX, W/ 6 FT. CABLE
16	CABLE: START LINE ELECTRONICS BOX TO TOWER J-BOX, 200 FT.
17	STARTERS CONSOLE BOX, W/ 20 FT. CABLE
18	3 AMPER STARTING TREE
19	CABLE: TREE TO START LINE ELECTRONICS BOX, 50 FT., ADAPTOR
20	PHOTOCELL LIGHT SOURCE; START LINE GUARD BEAM ADAPTOR
21	PHOTOCELL LIGHT SOURCE; START LINE GUARD BEAM ADAPTOR
22	CABLE: START PHOTOCELLS TO START LINE ELECTRONICS BOX, 20 FT.
23	PHOTOCELL LIGHT SOURCE; SINGLE LAMP
24	PHOTOCELL LIGHT SOURCE; DUAL LAMP
25	PHOTOCELL LIGHT SOURCE; DUAL LAMP
26	PHOTOCELL LIGHT SOURCE; DUAL LAMP
27	PHOTOCELL LIGHT SOURCE; DUAL LAMP
28	PHOTOCELL LIGHT SOURCE; DUAL LAMP
29	PHOTOCELL LIGHT SOURCE; DUAL LAMP
30	PHOTOCELL LIGHT SOURCE; DUAL LAMP
31	PHOTOCELL LIGHT SOURCE; DUAL LAMP
32	CABLE: PHOTOCELL TO FIELD CABLE 186A.
33	CABLE: PHOTOCELL TO FIELD CABLE 186A.
34	CABLE: PHOTOCELL TO FIELD CABLE 186A.
35	PHOTOCELL LAMP TRANSFORMER FINISH
36	PHOTOCELL LAMP TRANSFORMER FINISH
37	PHOTOCELL LAMP TRANSFORMER FINISH
38	PHOTOCELL LAMP TRANSFORMER FINISH
39	PHOTOCELL LAMP TRANSFORMER FINISH
40	PHOTOCELL LAMP TRANSFORMER FINISH
41	PHOTOCELL LAMP TRANSFORMER FINISH
42	PHOTOCELL LAMP TRANSFORMER FINISH
43	PHOTOCELL LAMP TRANSFORMER FINISH
44	PHOTOCELL LAMP TRANSFORMER FINISH
45	PHOTOCELL LAMP TRANSFORMER FINISH
46	PHOTOCELL LAMP TRANSFORMER FINISH
47	PHOTOCELL LAMP TRANSFORMER FINISH
48	PHOTOCELL LAMP TRANSFORMER FINISH
49	PHOTOCELL LAMP TRANSFORMER FINISH
50	PHOTOCELL LAMP TRANSFORMER FINISH
51	PHOTOCELL LAMP TRANSFORMER FINISH
52	PHOTOCELL LAMP TRANSFORMER FINISH
53	PHOTOCELL LAMP TRANSFORMER FINISH

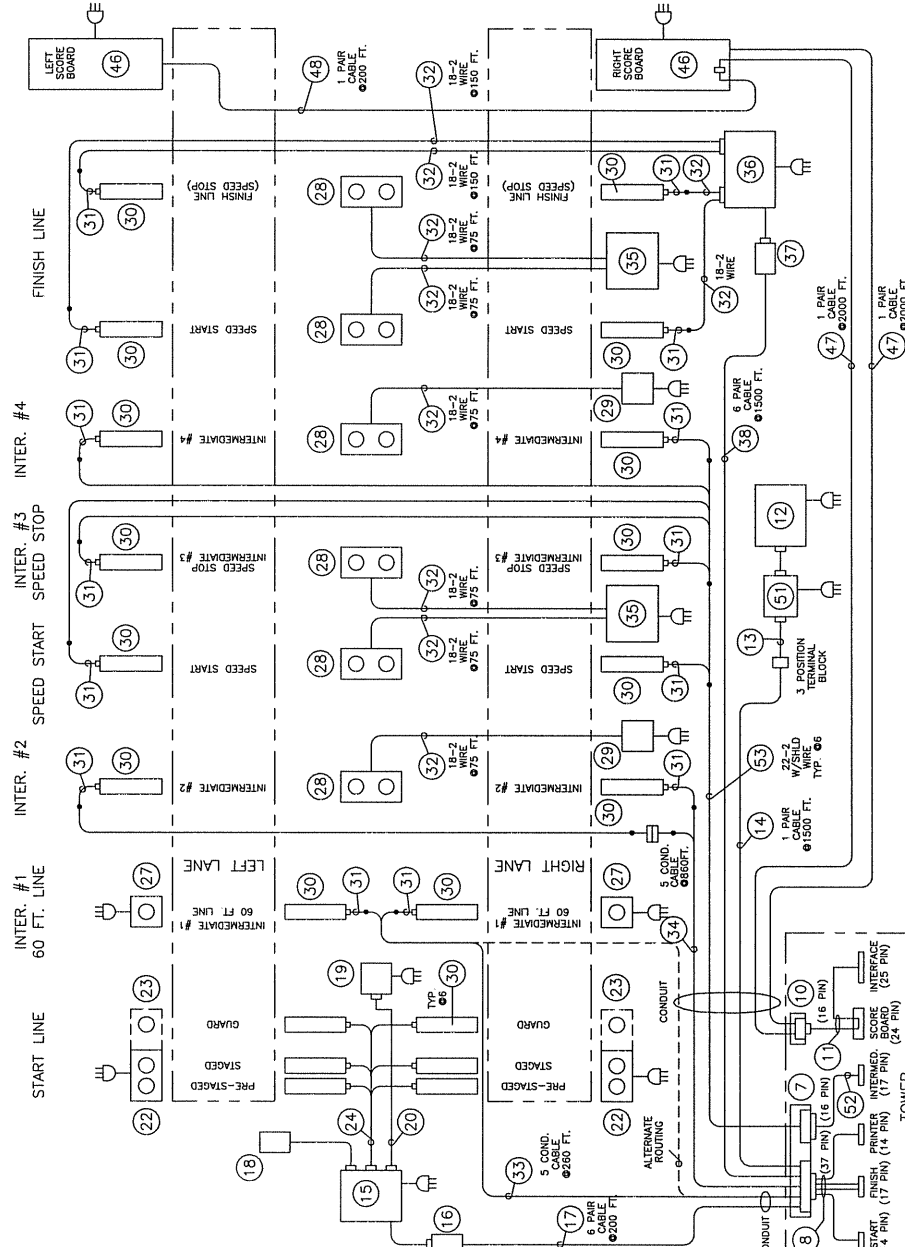

FIGURE 2.0

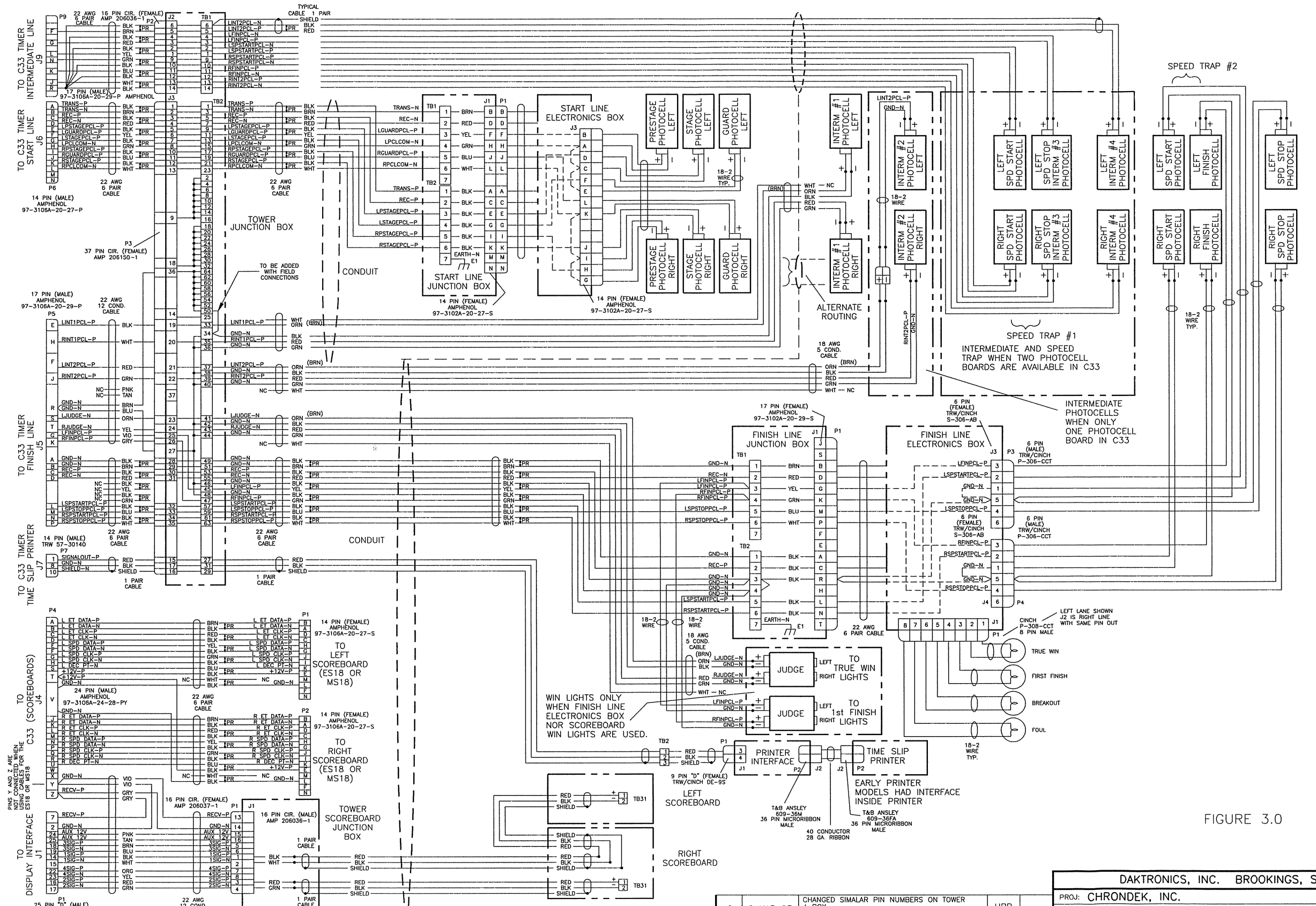

FIGURE 3.0

DAKTRONICS, INC. BROOKINGS, SD 57006			
PROJ: CHRONDEK, INC.			
TITLE: FIELD CABLING, C33 TIMER			
DES. BY:	DRAWN BY: M. RICHARDSON		DATE: 16 JAN 91
REVISION	APPR. BY:	SCALE: NONE 1067-R11B-45820	

REV	DATE	DESCRIPTION	BY	APPR.
2	6 MAR 97	CHANGED SIMILAR PIN NUMBERS ON TOWER J-BOX.	HBB	
1	10 OCT 95	CONNECTED PIN 17 OF J3 TO PIN 31 OF TB2 AND PIN 16 OF J3 TO PIN 29 OF TB2 ON TOWER JUNCTION BOX.	NJA	



## 2.4 LOCATION REQUIREMENTS

This section explains the equipment locations on the track for best operation. Such topics as conduit, power and electrical requirements, noise levels and other location considerations are discussed. Chrondek recommends that these guidelines be followed as closely as possible.

### 2.4.1 SIGNAL CONDUIT AND CABLE

Chrondek recommends that all cable be run in conduit. Refer to the cabling diagram (Figure 2) for conduit sizes and cable types.

### 2.4.2 POWER

The following is a list of electrical items and their respective power requirements.

UNIT	POWER REQUIREMENT (WATTS)
Start line Outlet	100
Tower Outlets	1800
C-33 Console	100
Color Monitor (C-33)	114
Printer (log or time slip)	84
Time Slip Printer Booth Outlet	200
60 ft. line outlet	30
1/8th mile line outlet	30
Start Line Electronics Box	100
Finish Line Electronics Box	100 (1000 with win lights)
Cars Computer (results)	100
Color Monitor (results)	102
Single Light Source	30
Dual Light Source	30
Light Source Transformer - Intermediate	30
Light Source Transformer - Finish	300
Three Amber Tree	2000 (minimum 20 amps)

TABLE 1. EQUIPMENT POWER REQUIREMENTS

### 2.4.3 ELECTRICAL

All electrical equipment used in the timing system runs on standard 120 Volts AC at 60 Hz.

#### **2.4.3.1 NOISE (RADIO/PA)**

The C-33 data cables must never be run with AC (power) or PA (Public Address) cables. The data cables may cross AC or PA cables when absolutely necessary but only at 90 degree angles. If it is necessary to run AC or PA cables parallel to data cable, the cables must not be closer than 24".

In addition, care must be taken to insure that radio transmitters or Television high voltage transmitters are far enough from the track to prevent noise interference. If these transmitters are close to the track, all cable must be shielded to prevent interference.

Care must be used to insure that the cable not be "crimped" or bent into too tight a radius. If it is necessary to put bends in conduit, they should be sweeping nineties.

#### **2.4.3.2 GROUNDING**

All equipment used with the timing system must be properly earth grounded. Make sure all outlets and cords are 3-conductor (grounded). All extension cords or extra wiring must be 3-conductor as well.

**Important** - Check to be sure that the Service Entrance (for the power) is properly earth grounded. If it is not grounded, have it properly grounded.

#### **2.4.3.3 ISOLATED POWER CIRCUITS**

Chrondek recommends that the control equipment (i.e. C-33 console) be on a dedicated power circuit to prevent noise interference. Air conditioners, fans, or high powered electrical equipment may cause noise interference or a "brown-out" which would reset the system.

#### **2.4.3.4 ELECTRICAL CODE**

The National Electrical Code and all local codes must be followed when installing electrical equipment. It is the responsibility of the installer to see that this is done. Equipment damage or personal injury can occur if these codes are not followed.

## 2.5 MOUNTING AND LOCATING EQUIPMENT

This section will explain how and where the track equipment should be mounted for a 1/8th and 1/4th mile track. The distances for track setup are national standards and should be followed.

### 2.5.1 MOUNTING AND SPEED TRAP DISTANCES

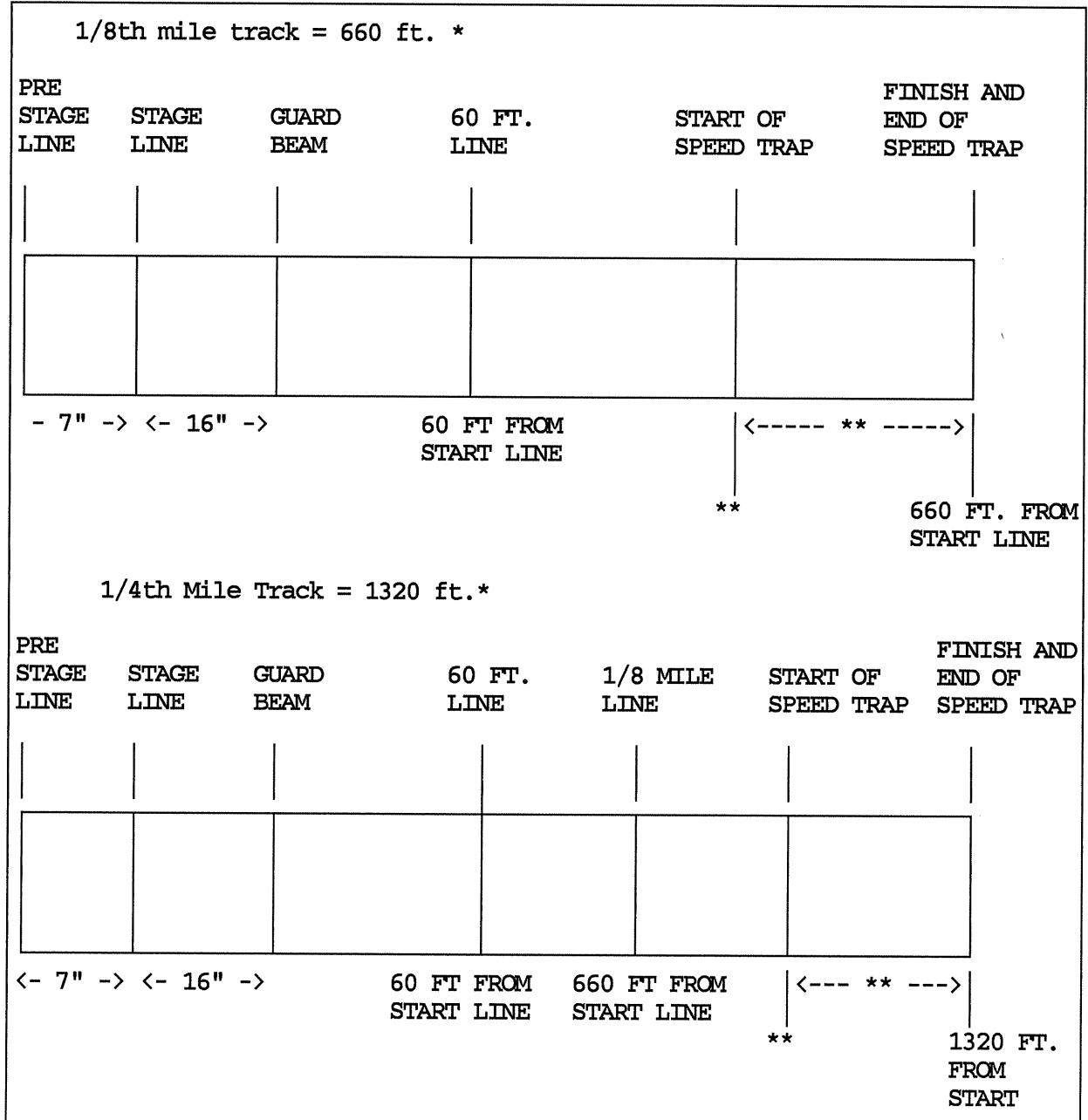

FIGURE 4 MOUNTING AND SPEED TRAP DISTANCE DIAGRAM

\* SEE NEXT PAGE

\*\* SEE NEXT PAGE

### 2.5.1 MOUNTING AND SPEED TRAP DISTANCES (CONTINUED)

\* WITH GUARD BEAM, THE START LINE IS THE GUARD BEAM LINE AND ALL POINTS SHOULD BE MEASURED FROM THERE. WITHOUT GUARD BEAM, THE START LINE IS THE STAGE LINE AND ALL POINTS SHOULD BE MEASURED FROM THERE.

\*\* Four different speed trap lengths can be used with the C-33. Each one starts at a different point. Find the length being used in the list below and mount the start of speed trap photocells that distance behind the finish line. General practice is to use the 66' speed trap.

#### Possible Speed trap lengths

2' 7-11/16"  
13' 2-3/8"  
66' 0"  
132' 0"

"Burn-out Box" = 90 ft. from designated box to start line.

### 2.5.2 PHOTOCELLS

**Rollout** Height of the beams must be adjusted as necessary, to provide 12" of roll using standard dragster wheel/tire (22" diameter). Beam height must be low enough to accommodate clearance rulings.

**Ground Mounting** All photocell mounts should be attached to the ground as conditions require on site. Start line (triple) brackets should be mounted far enough apart so one bracket ring holds the back end of the photocell secure, and the other ring holds the front end of the photocell secure.

**Pipe Mounting** Photocells with pipe mounts must be attached so the photocells are secure. The 60' photocell must be 10 1/2 inches above the crest of the track. All other interval photocells (i.e. 1/8th mile, speed trap, etc.) must be 6 inches above the crest of the track.

### 2.5.3 ADAPTING 3 POSITION TO 2 POSITION MOUNTING

If a guard beam is not being used, the three position mounting can be adapted to a two position mounting (see Figure 5). This does not have to be done. To remove, carefully bend the strip of metal holding the brackets on the perforation line to remove the third bracket.

# TRIPLE BRACKET MOUNT

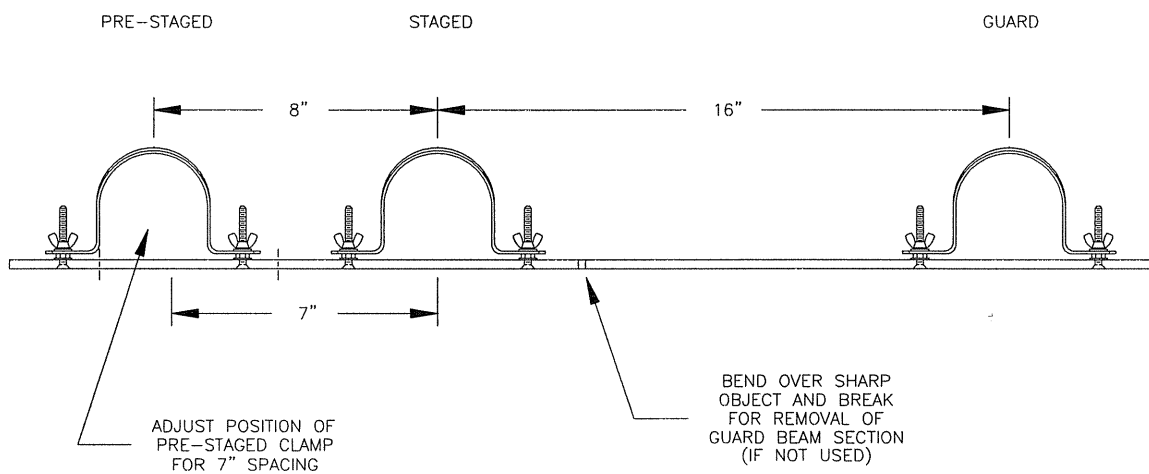

FIGURE 5.0

#### **2.5.4 TREE MOUNTING CONSIDERATIONS**

The distance from the start line to the tree must be 38 to 40 ft. The height of the tree should be 80 inches to the center of the pre-stage bulb from the ground.

#### **2.5.5 E.T. AND LOGGING PRINTER MOUNTING**

The E.T. or Logging printers will be either an EPSON LX-800 or C.ITOH standard printer. Locate the printers as shown in the system diagram (Figure 1). Care should be taken when choosing a site that can keep the printer from getting wet. The E.T. printer cable can be routed with the finish line cable or scoreboard cables. Shielding must be observed with the E.T. printer and scoreboard cables.

#### **2.5.6 START LINE ELECTRONICS BOX MOUNTING**

The Start Line Electronics Box is designed with all connections made with cable plugs. Locate the box in the start line area as shown on the system diagram. Note the cables that must be connected to the box: the Starters' Console, the Tree, Start Line Photocells, and connection to the Tower via the Start Line Junction Box.

The box is designed for portable operation. It is desirable to remove or cover it from the snow or rain environment. If intermediate or 60 foot timing options are used, it is possible to route photocell cables with the start line cable to the tower.

#### **2.5.7 FINISH LINE ELECTRONICS BOX MOUNTING**

The Finish Line Electronics Box connections are made with cable plugs. Locate the box in the finish line area as shown in the system diagram. Note the cables that are connected to the box: finish line and speed trap photocells, win lights (optional) and connection to the tower via the Finish Line Junction Box.

The box is designed for portable operation. It is desirable to remove or cover it from the snow or rain environment.

## 2.6 FIELD WIRING

This section pertains to the field wiring of the drag strip. The wiring will be done as follows: start line, intermediate, finish, and then tower. For all wiring, refer to the system diagram Figure 1 and pay close attention to the field cabling diagram Figure 3.

**WHEN MAKING CONNECTIONS, MAKE SURE ALL EQUIPMENT POWER IS OFF!**

Photocell connection: **CONNECT ALL PHOTOCELLS (EXCEPT THE START LINE PHOTOCELLS) IN THIS MANNER.** Photocells are connected to the cables using button connectors. Crimp the field cable to the button connectors using a splicer and button connector cable. Observe polarity, the ribbed or stripped conductor of the zip card is negative (-).

**NOTE:** The terminals on the photocells are polarized (i.e. care must be taken to connect the correct cable wires to the correct terminal). However, the light sources are not polarized so it does not matter which wire is connected to the light source terminals.

### 2.6.1 START LINE WIRING

The start line wiring consists of wiring the tower junction box, the start line junction box, start line electronics box, start line photocells, and the guard beam (optional).

#### 2.6.1.1 TOWER JUNCTION BOX

Cables coming in to the tower should come to the tower junction box. Refer to the drawing of the inside of the tower junction box (Figure 6) to aid in wiring.

#### 2.6.1.2 TOWER JUNCTION BOX TO START LINE JUNCTION BOX WIRING

The start line junction box is connected to the tower junction box using 6 pair 22 gauge cable. Spade lugs are used for wire connection on the start line junction box while wire clamps are provided in the tower junction box terminal blocks. Follow the wiring table for connections and see Figure 7.

TOWER JUNCTION BOX

WIRE PREPARATION DETAIL

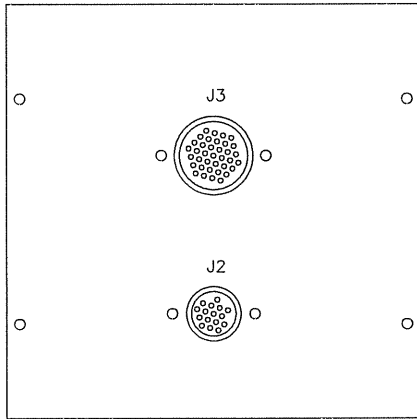

FRONT VIEW

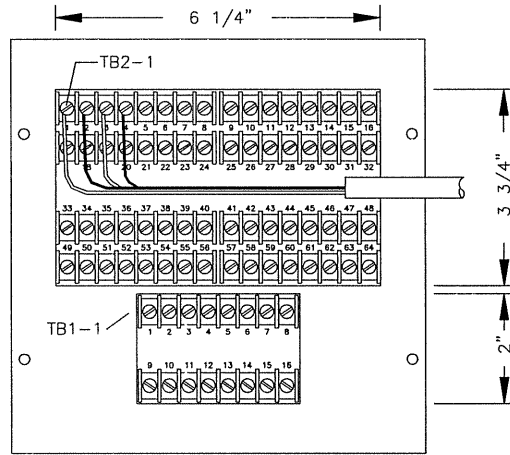

BACK VIEW

SURFACE MOUNTING BOX

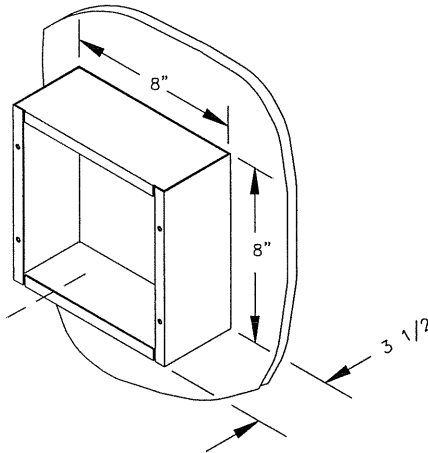

SIDE VIEW

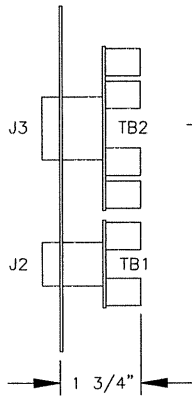

FLUSH MOUNTING BOX

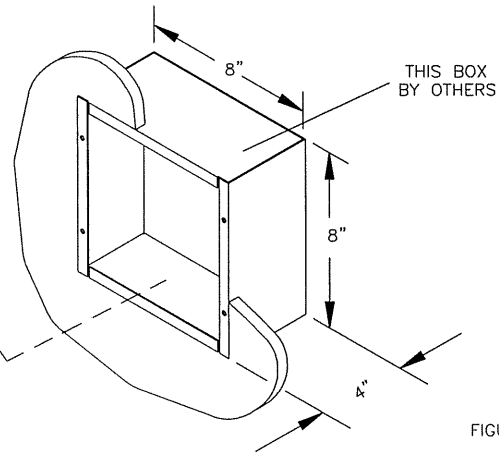
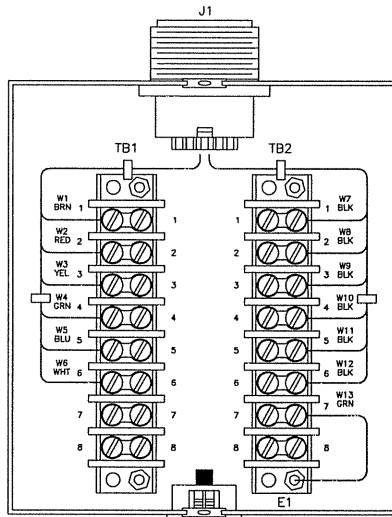

FIGURE 6.0



START LINE  
JUNCTION BOX  
(TOP VIEW W/O COVER)

TO START LINE  
ELECTRONICS BOX



BOX SIZE  
5" X 4-1/2" X 2-1/2"  
(L X W X H)

FIELD CABLE TO  
TOWER JUNCTION BOX

START LINE  
JUNCTION BOX  
J1

SCHEMATIC

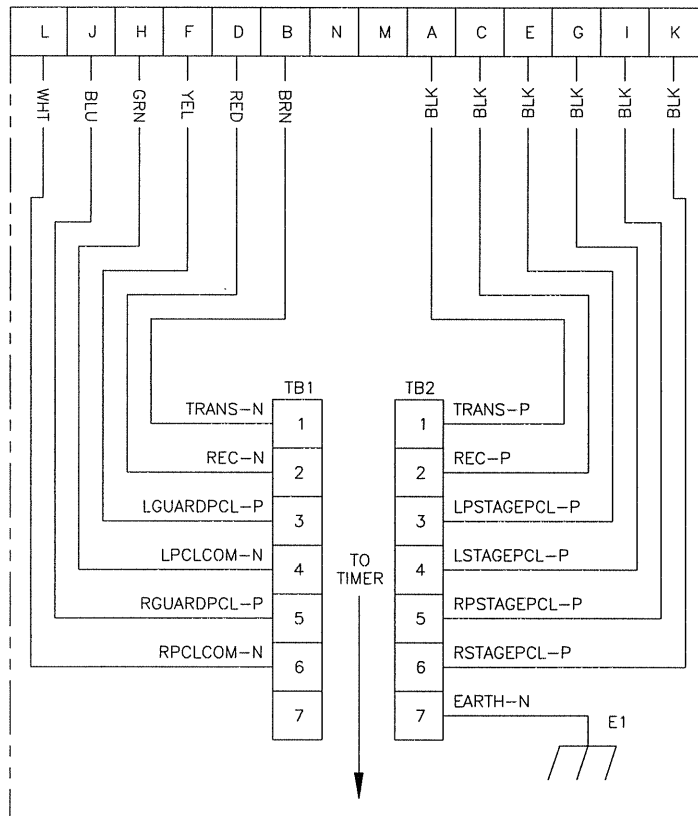

FIGURE 7.0

**2.6.1.2 TOWER JUNCTION BOX TO START LINE JUNCTION BOX WIRING  
(CONTINUED)**

PAIR COLORS*	WIRE COLOR	FROM (TJB)	TO (SLJB)	FUNCTION
BLK/BRN	BLK BRN	TB2-1 TB2-3	TB2-1 TB1-1	TRANS-P TRANS-N
BLK/RED	BLK RED	TB2-5 TB2-7	TB2-2 TB1-2	REC-P REC-N
BLK/YEL	BLK YEL	TB2-9 TB2-11	TB2-3 TB1-3	LPSTAGEPCL-P LGPCLCOM-N
BLK/GRN	BLK GRN	TB2-13 TB2-15	TB2-4 TB1-4	LSTAGEPCL-P LPCLCOM-N
BLK/BLU	BLK BLU	TB2-17 TB2-19	TB2-5 TB1-5	RPSTAGEPCL-P RGPCLCOM-N
BLK/WHT	BLK WHT	TB2-21 TB2-23	TB2-6 TB1-6	RSTAGEPCL-P RPCLCOM-N
		TB2-34 TO TB2-50		JUMPER

Table 2. TJB to SLJB wiring table

\* Color pairs are for example: BLACK wire twisted with a BROWN wire.

**2.6.2 START LINE ELECTRONICS BOX (SLEB) (See Figure 8)**

All connections to the Start Line Electronics Box are made with plug in connections. See the Operational Check (Section 2.7) for connection and power up procedure.

**2.6.3 START LINE PHOTOCELLS**

The cable used for connecting the start line photocells to the SLEB (6-conductor cable) is pre-marked showing which photocell it connects to. Connect the cable to the photocells as marked.

**2.6.4 START LINE LIGHT SOURCES**

Plug in the left and right dual light sources into the start line outlets. See Figure 9.

START LINE  
ELECTRONICS BOX  
(TOP VIEW W/O COVER)

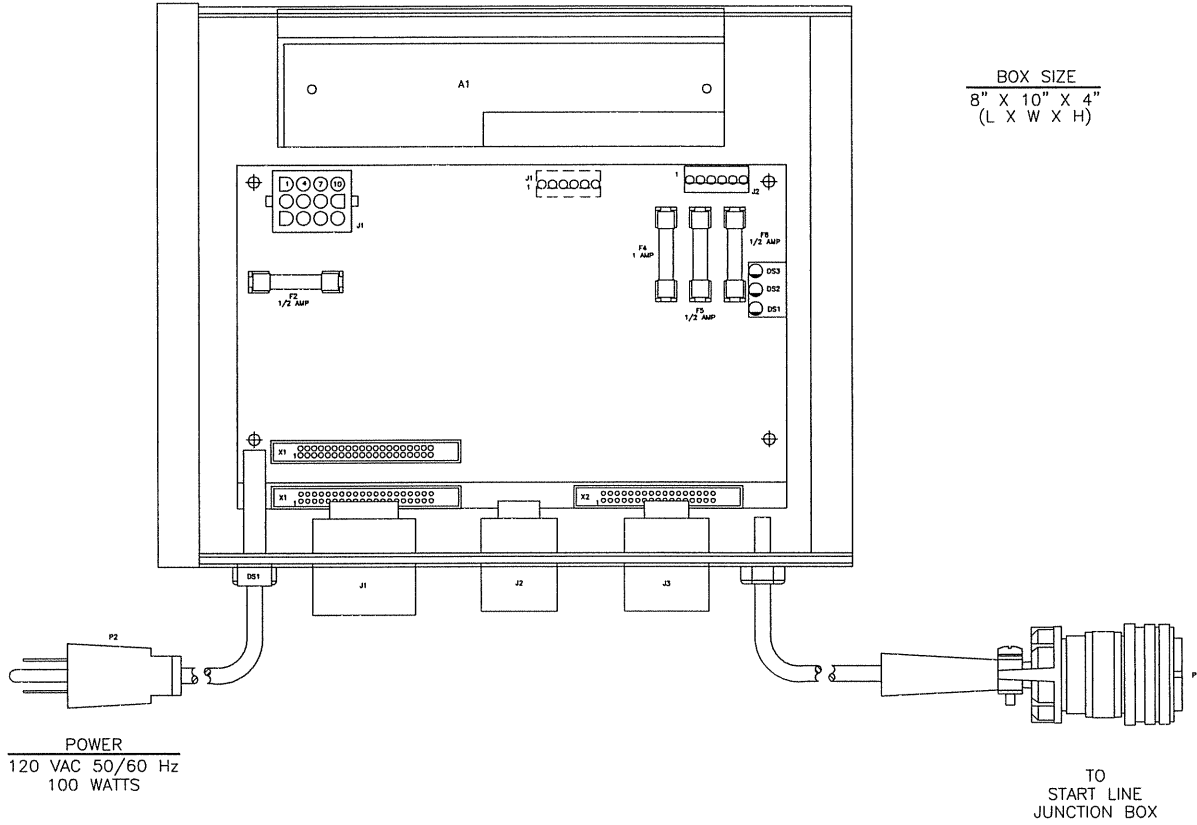

BOX SIZE  
8" X 10" X 4"  
(L X W X H)

POWER  
120 VAC 50/60 Hz  
100 WATTS

TO  
START LINE  
JUNCTION BOX

START LINE  
ELECTRONICS BOX  
(FRONT VIEW)

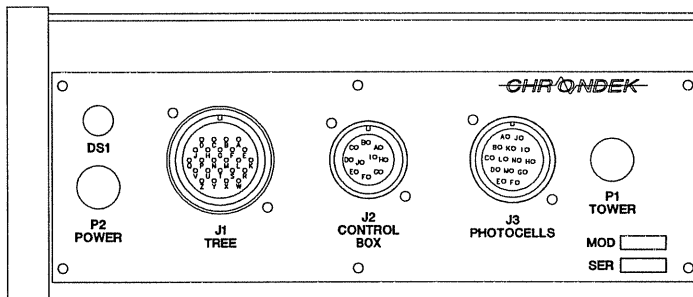
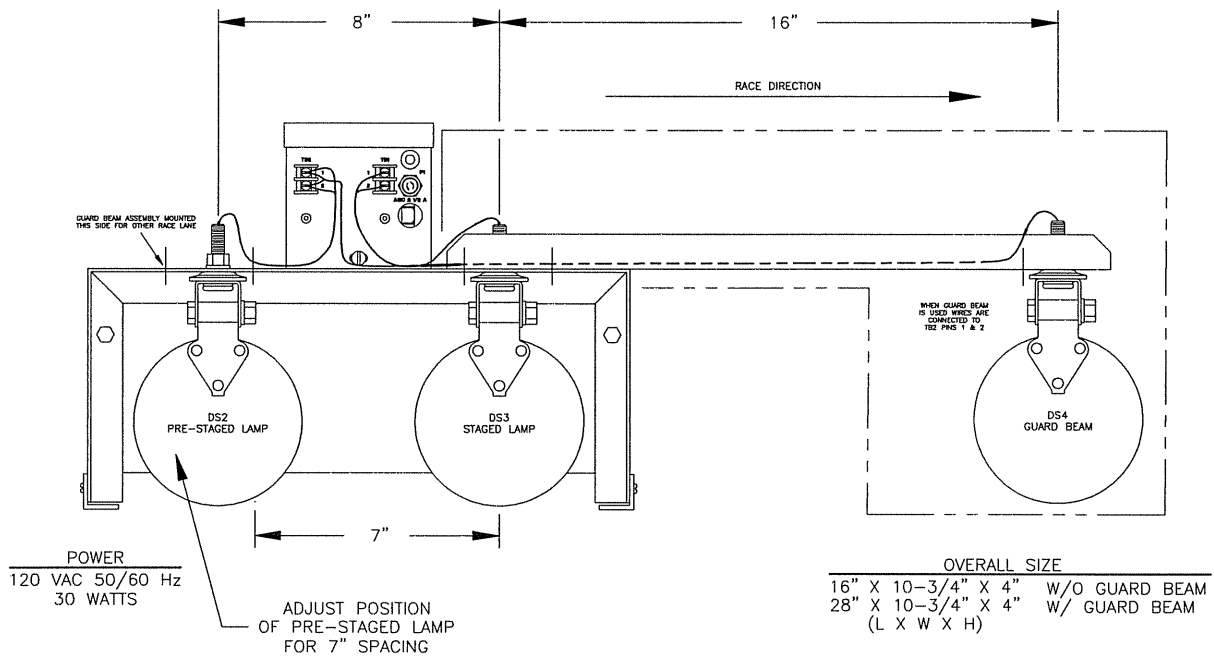

FIGURE 8.0

# START LINE DUAL LIGHT SOURCE

(REAR VIEW)



## SCHEMATIC

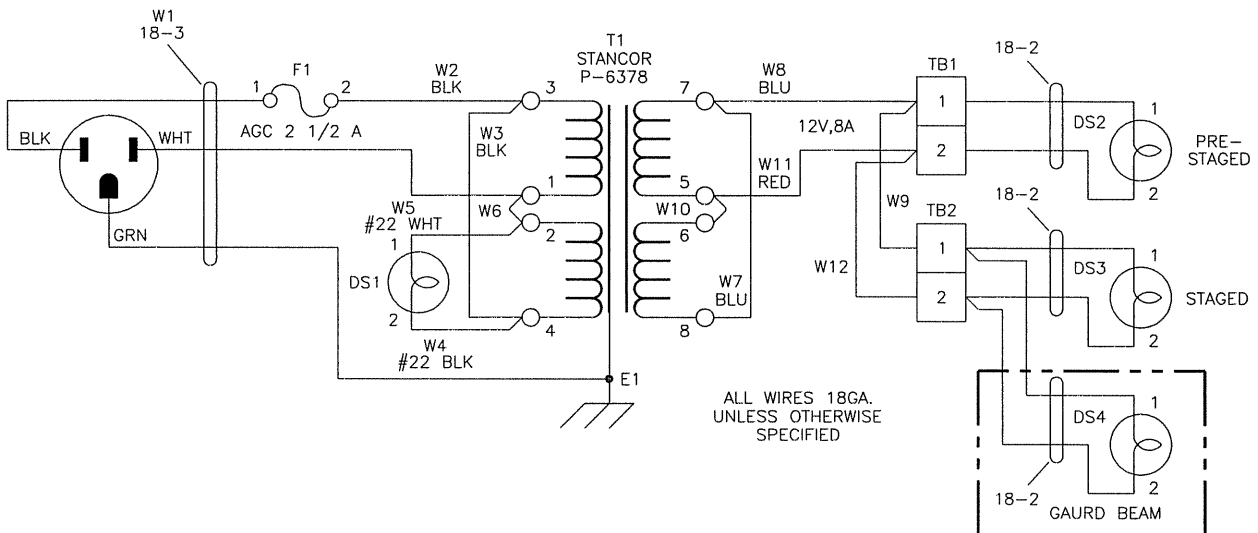

FIGURE 9.0

#### **2.6.5 GUARD BEAM INSTALLATION (OPTIONAL)**

Insert the guard beam photocell into the third bracket of the triple photocell brackets (Figure 5) which hold the start line photocells. Connect the photocell as mentioned above.

Attach the guard beam extension arms on to the left and right dual light sources as shown in Figure 8. Connect the wires coming from the guard beam lamp into TB1-1 and TB1-2 on the dual light source as shown in the figure. The polarity of the wires does not matter.

#### **2.6.6 INSTALLATION OF THE 3-AMBER TREE**

The Chrondek 3 Amber Tree is totally compatible with all Chrondek C-33 race controllers. To install the 3 amber tree, connect the tree cable into the connector on the rear side of the tree. Plug the AC power cord into an outlet capable of supplying a **minimum** of 20 amps. Regulations stipulate that the pre-stage bulb should be approximately 80 inches from the ground so a longer mounting pipe will be necessary in some cases.

Eight, 60 Watt yellow "bug" lights should be used for the stage and pre-stage lamps. (There are two bulbs for each stage and pre-stage position to prevent confusion should one bulb burn out.) The 12 amber, 4 green, and 4 red lamps should be standard 85-watt colored flood lamps (GE part #13472 red, #13474 green, 13463 amber). These should be installed in the sockets using the supplied gasket to provide adequate bulb support and moisture protection. The gaskets should be used with the lamp sockets to seal and prevent vibration. The blue Sure Start lamp (if used) may be any blue-colored reflector type bulb rated at 100 watts or less.

Due to the increased power consumption of this Christmas Tree, it is essential that the tree is connected to a power supply sufficient enough to supply the minimum 20-amp current AT THE OUTLET. If the power available is insufficient, some slight dimming of the staging lamps will be noticed. This will not harm the tree, nor is it a problem with the tree. The use of long extension cords should be avoided. (See maintenance section for details on maintenance.)

#### **2.6.7 INTERMEDIATE WIRING (OPTIONAL)**

This section consists of wiring the intermediate section of the track. This includes the 60 foot intermediate equipment, and the 1/8th mile equipment. This section may not apply unless the options are being used.

STARTING TREE

 TREE PACKING  
 W/O TOP

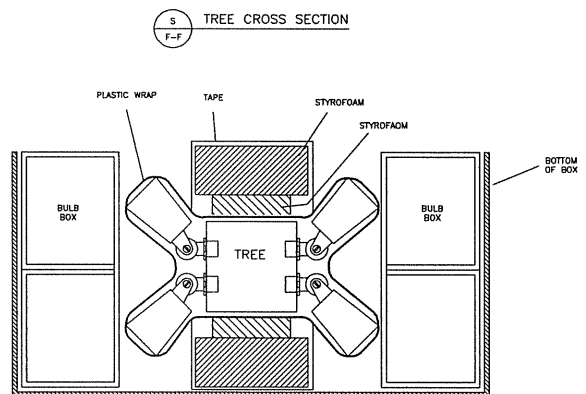
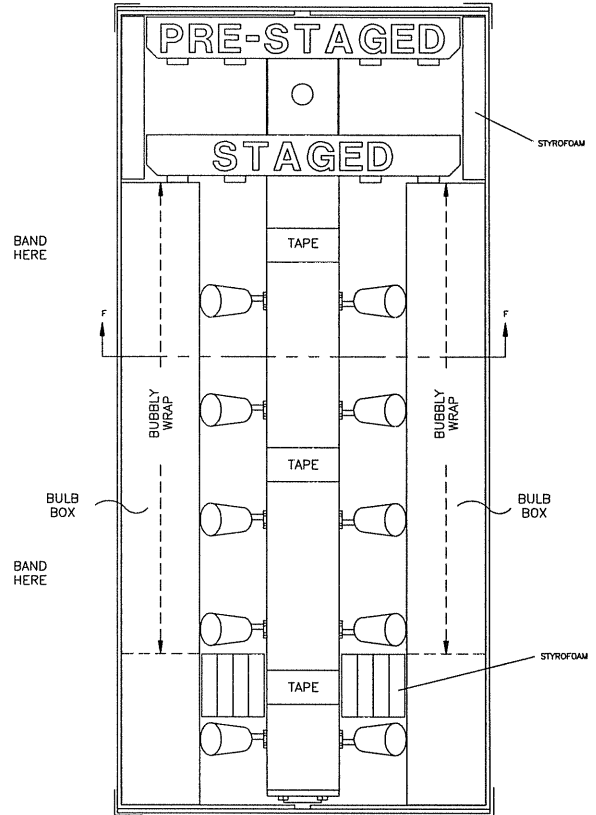
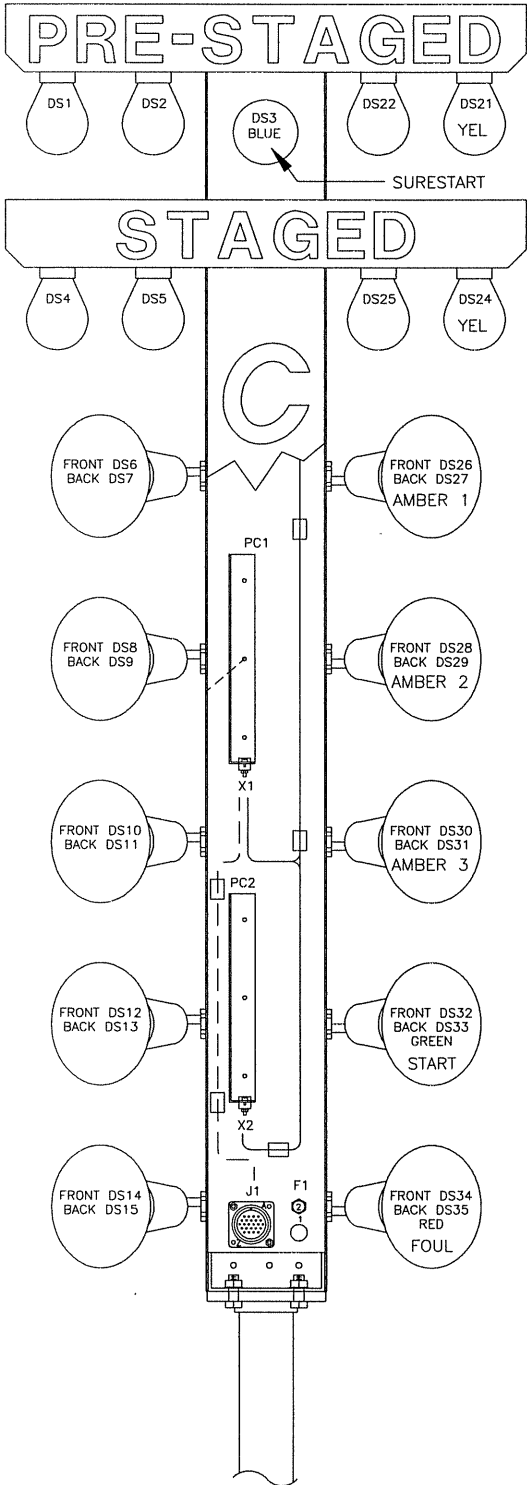

FIGURE 9.1

### 2.6.7.1 INTERMEDIATE PHOTOCELLS AND LIGHT SOURCES

#### 60' Intermediate photocell wiring

Wiring between the tower junction box and the 60' intermediate photocells uses 5 conductor cable. Wire clamps are used for connection in the tower junction box. Connect the photocells as mentioned in Section 2.6. See the following connection table for connections as well as the field cabling diagram (Figure 3).

WIRE COLOR	FROM (TJB)	TO (PCLS) *	FUNCTION
WHT	NO CONNECTION		
ORN	TB2-33	LEFT PCL +	LINT1PCL-P
BLK	TB2-34	LEFT PCL -	GND-N
RED	TB2-35	RIGHT PCL +	RINT1PCL-P
GRN	TB2-36	RIGHT PCL -	GND-N

Table 3. 60' intermediate photocell wiring list

\* The ribbed wire is the negative conductor of the photocell zip cord.

#### Intermediate light source wiring 60'

Plug the power cable from the intermediate light sources into the outlet. See Figure 10.

#### 1/8th Mile Intermediate photocell wiring

Wiring between the tower junction box and the 1/8th mile photocells uses 5 conductor cable. Wire clamps are used for connection to the tower junction box. See the following connection table for wire connections and also the field cabling diagram (Figure 3).

WIRE COLOR	FROM (TJB)	TO (PCLS) *	FUNCTION
ORN	TB2-37	LEFT PCL +	LINT2PCL-P
BLK	TB2-38	LEFT PCL -	GND-N
RED	TB2-39	RIGHT PCL +	RINT2PCL-P
GRN	TB2-40	RIGHT PCL -	GND-N
WHT	NO CONNECTION		

Table 4. 1/8th mile wiring list

\* The ribbed wire is the negative conductor of the photocell zip cord.

SINGLE LIGHT SOURCE  
INTERMEDIATE

REAR VIEW

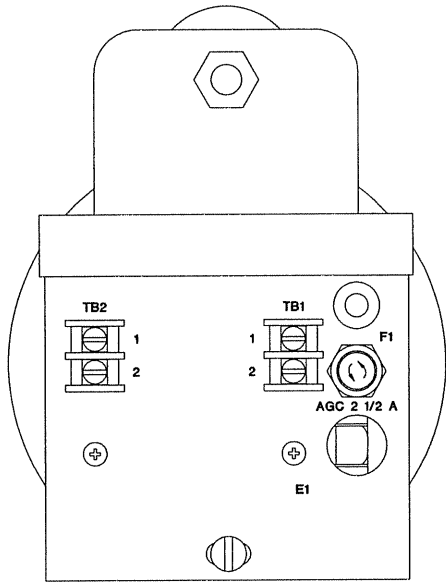

SIDE VIEW

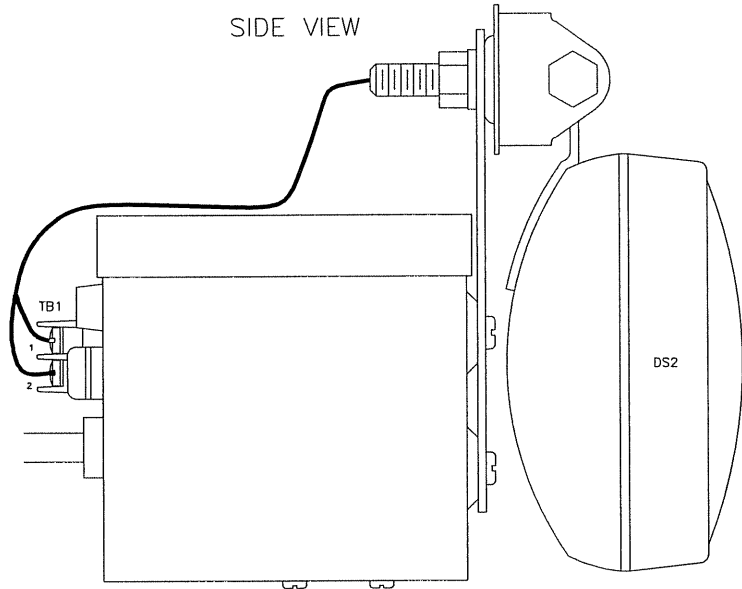

POWER  
120 VAC 50/60 Hz  
30 WATTS

OVERALL SIZE  
4-3/4" X 7" X 6-1/2"  
(L X W X H)

SCHEMATIC

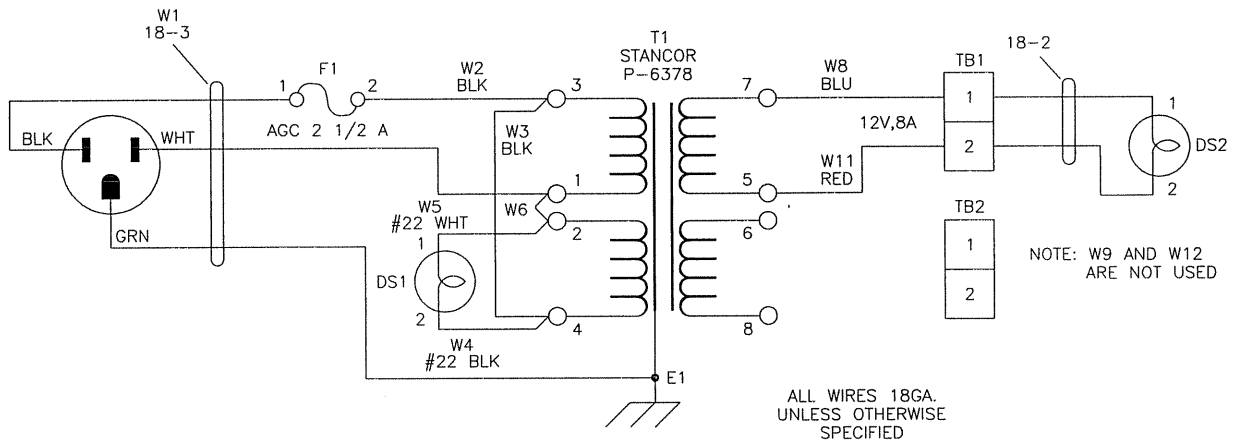

FIGURE 10.0



### Intermediate light source wiring 1/8th mile

Position the light source in the middle of the track as shown in the system diagram. Connect the cable that will run to the intermediate transformer to the light source.

#### **2.6.7.2 INTERMEDIATE TRANSFORMER**

Attach the cable coming from the 1/8th mile dual light source to the top of the transformer to the screws using spade lugs (TB1-1 & 2) (See Figure 11). The polarity does not matter on the transformer. Plug in the intermediate transformer into the power outlet after connecting.

#### **2.6.8 FINISH LINE WIRING**

This section explains the wiring for the finish line. This consists of the finish line junction box, the finish line electronics box, the win lights when driven by the finish line electronics box, and the speed trap photocells and light sources.

##### **2.6.8.1 FINISH LINE JUNCTION BOX WIRING**

Wiring between the tower junction box and the finish line junction box uses 22 gauge 6 pair cable. Spade lugs are used for connection to the finish line junction box while wire clamps are provided for connection in the tower junction box. See the following wire connection table and Figure 12 as well as field cabling diagram Figure 3.

# INTERMEDIATE TRANSFORMER

POWER  
120 VAC 50/60 Hz  
30 WATTS

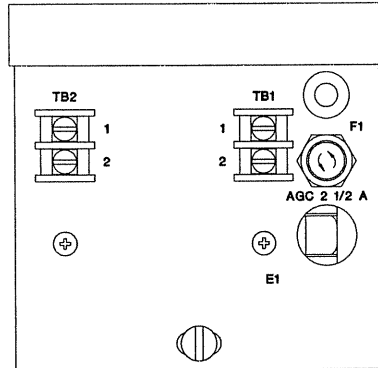

BOX SIZE  
4" X 4" X 4"  
(L X W X H)

## SCHEMATIC

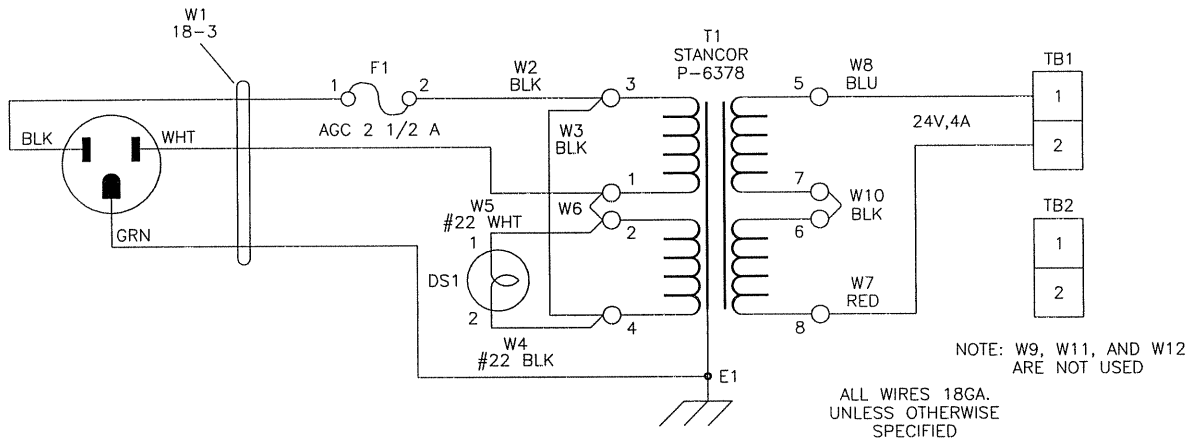

FIGURE 11.0

### 2.6.8.1 FINISH LINE JUNCTION BOX WIRING (CONTINUED)

PAIR COLORS*	WIRE COLOR	FROM (TJB)	TO (FLJB)	FUNCTION
BLK/BRN	BLK BRN	TB2-49 TB2-51	TB2-1 TB1-1	GND-N GND-N
BLK/RED	BLK RED	TB2-53 TB2-55	TB2-2 TB1-2	REC-P REC-N
BLK/YEL	BLK YEL	TB2-46 TB2-45	TB2-3 TB1-3	GND-N LFINPCL-P
BLK/GRN	BLK GRN	TB2-48 TB2-47	TB2-4 TB1-4	GND-N RFINPCL-P
BLK/BLU	BLK BLU	TB2-57 TB2-59	TB2-5 TB1-5	LSPSTARTPCL-P LSPSTOPPCL-P
BLK/WHT	BLK WHT	TB2-61 TB2-63	TB2-6 TB1-6	RSPSTARTPCL-P RSPSTOPPCL-P
	GRN	TB2-3	TB2-4	JUMPER

Table 5. TJB to FLJB wiring list

### 2.6.8.2 FINISH LINE ELECTRONICS BOX

All connections to the Finish Line Electronics Box are made with plug in connections. See the Operational Check (Section 2.7) for connection and power up procedures. See Figure 13.

#### Win Light plug soldering (optional)

If the track is using win lights that are being driven from the finish line electronics box, the plugs which connect into the finish line electronics box must be soldered to the cables. (See Finish Line Electronics Box schematic Figure 24). Remove the cover on the plug to see the pin numbers. Two wiring lists follow, one for the right win lights, and one for the left.

**FINISH LINE  
JUNCTION BOX**  
(TOP VIEW W/O COVER)

TO FINISH LINE  
ELECTRONICS BOX

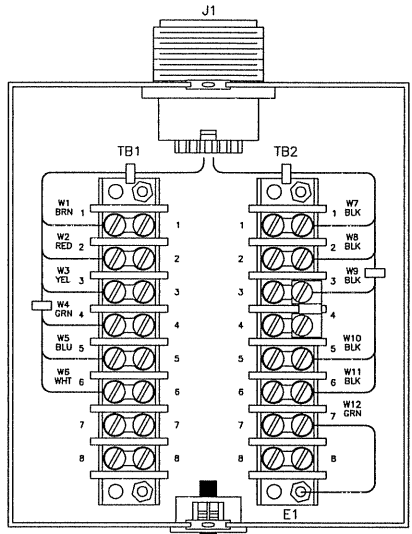

BOX SIZE  
5" X 4-1/2" X 2-1/2"  
(L X W X H)

FIELD CABLE TO  
TOWER JUNCTION BOX

**FINISH LINE  
JUNCTION BOX  
J1**

SCHEMATIC

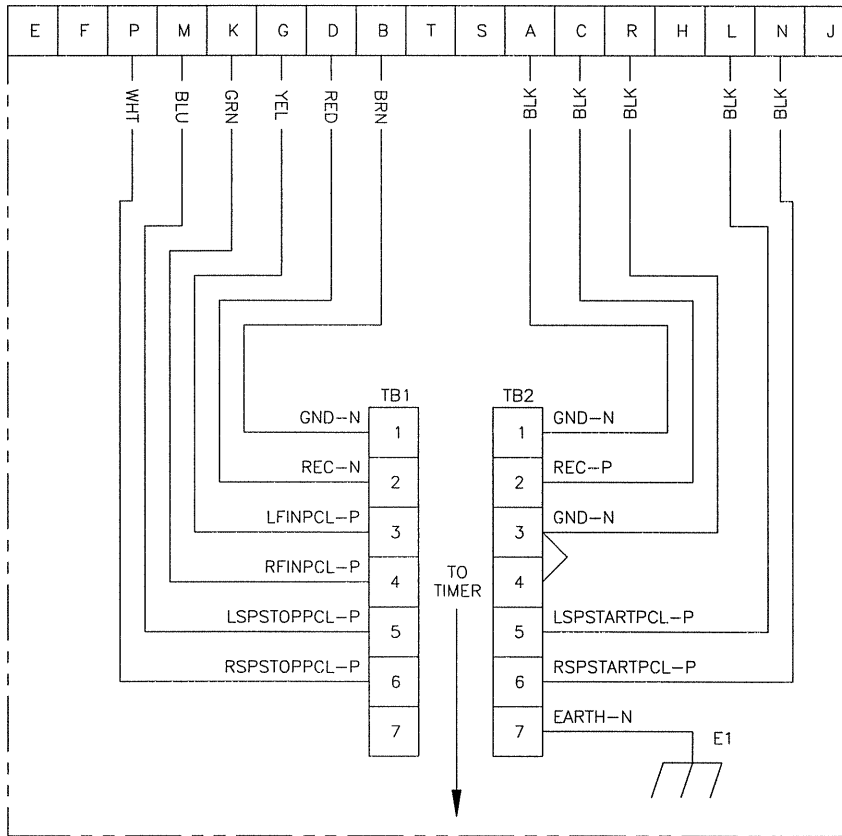
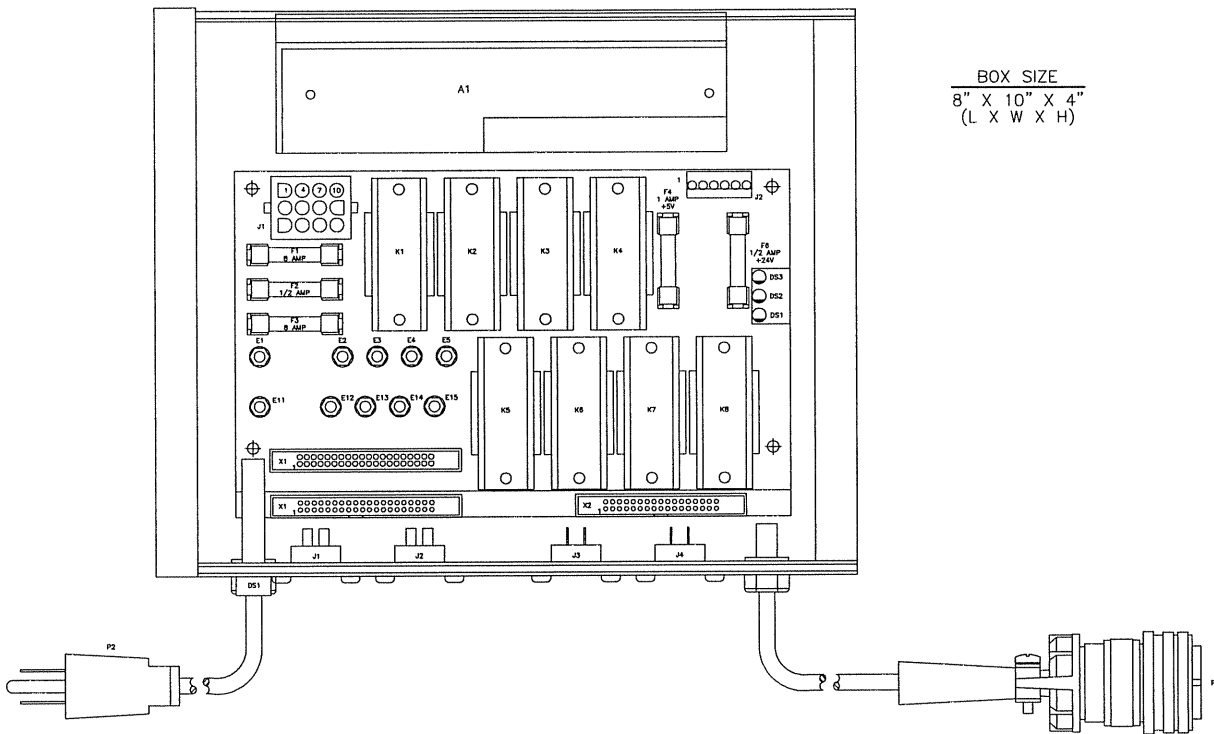

FIGURE 12.0

**FINISH LINE  
ELECTRONICS BOX**

(TOP VIEW W/O COVER)



**BOX SIZE**  
8" X 10" X 4"  
(L X W X H)

**POWER W/ WIN LIGHTS**  
120 VAC 50/60 Hz  
1000 WATTS

**POWER W/O WIN LIGHTS**  
120 VAC 50/60 Hz  
100 WATTS

TO  
FINISH LINE  
JUNCTION BOX

**FINISH LINE  
ELECTRONICS BOX**

(FRONT VIEW)

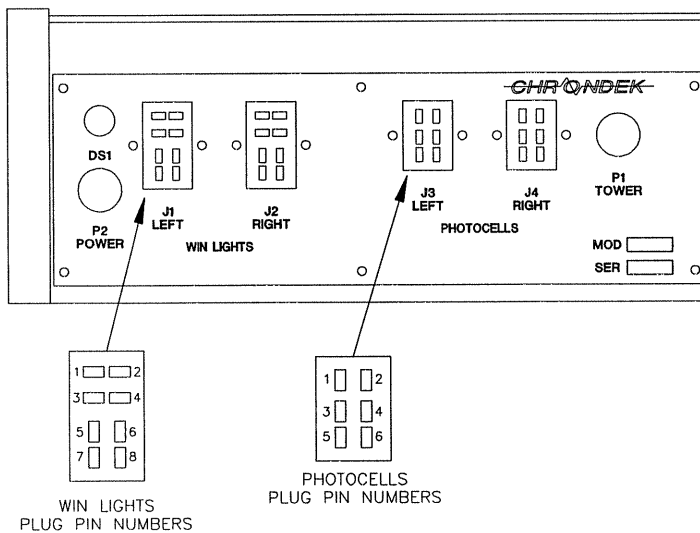

FIGURE 13.0

**2.6.8.2 FINISH LINE ELECTRONICS BOX (CONTINUED)**

PLUG-PIN NO.	CONNECTION
1	LEFT TRUE WIN SWITCHED 120 VAC
2	LEFT TRUE WIN NEUTRAL
3	LEFT FIRST TO FINISH SWITCHED 120 VAC
4	LEFT FIRST TO FINISH NEUTRAL
5	LEFT BREAKOUT SWITCHED 120 VAC
6	LEFT BREAKOUT NEUTRAL
7	LEFT FOUL SWITCHED 120 VAC
8	LEFT FOUL NEUTRAL

TABLE 6. LEFT WIN LIGHT PLUG SOLDERING CONNECTIONS

PLUG-PIN NO.	CONNECTION
1	RIGHT TRUE WIN SWITCHED 120 VAC
2	RIGHT TRUE WIN NEUTRAL
3	RIGHT FIRST TO FINISH SWITCHED 120 VAC
4	RIGHT FIRST TO FINISH NEUTRAL
5	RIGHT BREAKOUT SWITCHED 120 VAC
6	RIGHT BREAKOUT NEUTRAL
7	RIGHT FOUL SWITCHED 120 VAC
8	RIGHT FOUL NEUTRAL

TABLE 7. RIGHT WIN LIGHT PLUG SOLDERING CONNECTIONS

**Finish line photocell plug soldering**

The plugs which connect the finish line photocells to the finish line electronics box must be soldered to the cables. Remove the cover on the plugs to see the jack numbers. See the following wire connection tables.

**SPEED TRAP START PHOTOCELLS AND FINISH LINE PHOTOCELLS** Wiring between the finish line electronics box plug and the speed trap start and finish line photocells use 18/2 zip cord. See the following wire connection tables.

### 2.6.8.2 FINISH LINE ELECTRONICS BOX (CONTINUED)

FROM (PCLS)	TO (PLUG) JACK NO.	FUNCTION
RIGHT SPEED TRAP START PCL -	1	GND-N
RIGHT SPEED TRAP START PCL +	2	RSPSTARTPCL-P
RIGHT FINISH LINE PCL +	3	RFINPCL-P
RIGHT FINISH LINE PCL -	5	GND-N
	4	RSPSTOPPCL-P

TABLE 8. RIGHT SPEED TRAP START AND FINISH LINE PCLS TO FLEB PLUG CONNECTIONS

FROM (PCLS)	TO (PLUG) JACK NO.	FUNCTION
LEFT SPEED TRAP START PCL -	1	GND-N
LEFT SPEED TRAP START PCL +	2	LSPSTARTPCL-P
LEFT FINISH LINE PCL +	3	LFINPCL-P
LEFT FINISH LINE PCL -	5	GND-N
	4	LSPSTOPPCL-P

TABLE 9. LEFT SPEED TRAP START AND FINISH LINE PCLS TO FLEB PLUG CONNECTIONS

### 2.6.8.3 FINISH LINE TRANSFORMER

Attach the cables from each dual light source to the top of the transformer to TB1-1 and TB1-2 (put spade lugs on wire ends then slip under the screws). The polarity does not matter. Plug the transformer (shown in Figure 14) into the finish line outlet.

### 2.6.8.4 TIME SLIP PRINTER WIRING

The cable for the time slip printer is a three-part cable with two terminal blocks. The cable comes this way so the printer can be connected directly to the C-33 without running it through the tower junction box (so the printer can be kept in the tower or so the printer can be tested before moving it to the printer booth).

If the printer is to be kept in the printer booth, only the last segment of the printer cable (the segment that connects to the printer) will be used. Connect this segment to the printer, and then connect the 1000 ft. of printer extension cable to the segment and run it to the tower. See the following wire connecting table for connecting the cable (3 conductor) to the tower junction box.

**2.6.8.4 TIME SLIP PRINTER WIRING (CONTINUED)**

WIRE COLOR	TO (TJB)	FUNCTION
RED	TB2-27	POSITIVE
BLK	TB2-29	NEGATIVE
BRAID	TB2-31	SHIELD

Table 10. Time slip printer wiring

**2.6.8.5 JUDGE SYSTEM WIRING FOR TRUE WIN CAPABILITY (OPTIONAL)**

Wiring between the tower junction box and the Judge System when used for True Win capabilities (i.e. hooked to C-33) uses 5 conductor cable. Use zip cord and button connectors at the judge end.

WIRE COLOR	FROM (TJB)	TO (JUDGE)	FUNCTION
ORN	TB2-41	LEFT + TERM	LJUDGE-N
BLK	TB2-42	LEFT - TERM	GND-N
RED	TB2-43	RIGHT + TERM	RJUDGE-N
GRN	TB2-44	RIGHT - TERM	GND-N
WHT	NO CONNECTION		

Table 11. Judge system to C-33 wiring list

**2.6.8.6 JUDGE SYSTEM WIRING FOR FIRST TO FINISH (OPTIONAL)**

Wiring between the finish line junction box and the Judge System when used for first-to-finish capabilities (i.e. hooked to Finish Line Junction Box) uses 18/2 zip cord for connections. See the following connection list. Use zip cord and button connector at the judge end.

FROM (TJB)	TO (JUDGE)	FUNCTION
TB2-4	RIGHT - TERM	GND-N
TB1-4	RIGHT + TERM	RFINPCL-P
TB2-3	LEFT - TERM	GND-N
TB1-3	LEFT + TERM	LFINPCL-P

Table 12. Judge system to FLJB wiring list



# FINISH LINE TRANSFORMER

POWER  
120 VAC 50/60 Hz  
300 WATTS

BOX SIZE  
8" X 10" X 4"  
(L X W X H)

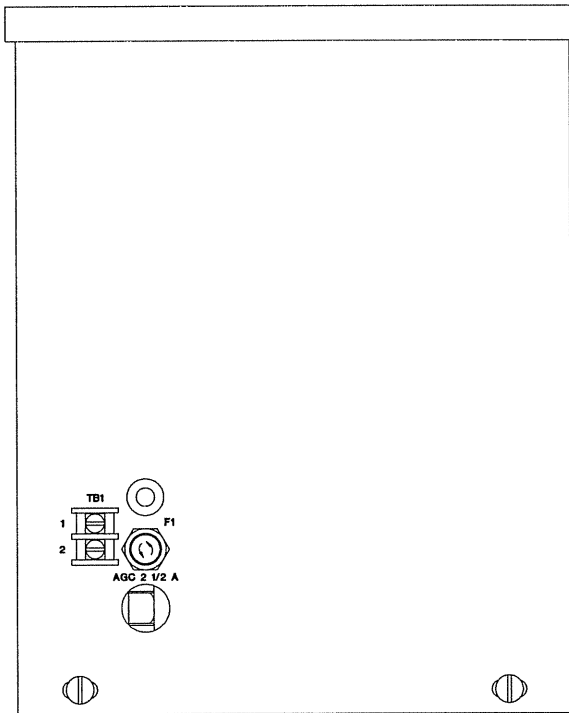

## SCHEMATIC

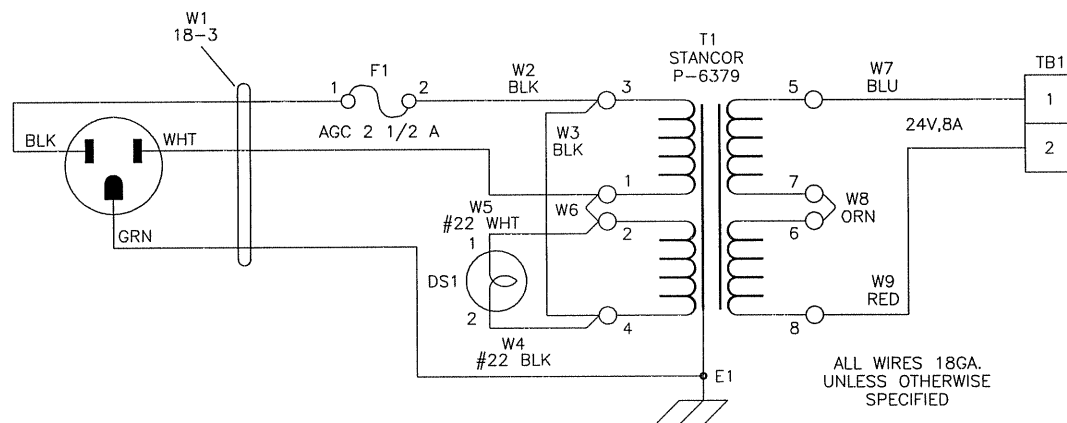

FIGURE 14.0

**2.6.8.7 OPTIONAL: WIRING BETWEEN THE SCOREBOARD INTERFACE AND THE RIGHT SCOREBOARD**

Wiring between the scoreboard interface and the right scoreboard use 1 pair shielded cable. See the following wire connection table.

WIRE COLOR	FROM (INTER)	TO (SCBD)	FUNCTION
RED	P1-3	TB31-1	POSITIVE
BLK	P1-4	TB31-2	NEGATIVE
BRAID	NC	NC	SHIELD

Table 13. Scoreboard interface to right scoreboard wiring list

**2.6.8.8 OPTIONAL: WIRING BETWEEN THE SCOREBOARD INTERFACE AND THE LEFT SCOREBOARD**

WIRE COLOR	FROM (INTER)	TO (SCBD)	FUNCTION
RED	P1-1	TB31-1	POSITIVE
BLK	P1-2	TB31-2	NEGATIVE
BRAID	NC	NC	SHIELD

Table 14. Scoreboard interface to left scoreboard wiring list

## 2.7 OPERATIONAL CHECK

During the Operational Check, the final connections are made on the system and preliminary tests are done to determine if all the equipment is working properly. First the equipment in the tower is checked, then the start line, the intermediate equipment, and finally, the finish line.

### 2.7.1 TIMER - MONITOR - KEYBOARD

This section will cover the connection of the equipment in the tower. Refer to the system diagram and cabling diagram for information on the items that connect to the C-33. See Figure 15 to view the back panel of the C-33.

-Connect the cable that came with the video monitor to the port marked "VIDEO" on the back of the C-33. The power switch is on the upper right side of the monitor.

-Connect the cable that came with the keyboard to the port marked "KEYBOARD" on the back of the C-33.

-Plug the C-33 and the monitor into a tower outlet. Other equipment will be connected as the system is turned on.

Make sure the timer and monitor are plugged in. Turn on the power to the C-33 and monitor. Check to be sure the red power button lights when turned on and the fan in the rear of the console is moving air. Make sure a clear picture of the C-33 main screen appears on the monitor. Some adjusting of the monitor brightness or focus may be necessary.

Use the keyboard to type in sample drivers' names, etc. to test if the keyboard is operating properly. Next, the equipment that connects to the C-33 will be connected.

-Using the C-33 to tower junction box cable, connect it to the start line port.

-Connect the logging printer cable into the port marked "TOWER PRINTER" on the back of the C-33. See the printer users manual for instructions on how to insert the paper (8 1/2" by 11" white paper with tear off edges should be used). Connect the other end to the logging printer.

-OPTIONAL: If a results system is being used, connect the results system cable to the port marked "COMMUNICATIONS" on the back of the C-33 and the serial port of the results computer.

### **2.7.2    TIMER - START LINE - EMERGENCY**

#### **Start Line Electronics Box    (See Figure 8)**

-Connect the power to the SLEB.

-Connect the cable coming from the tree into the port marked "TREE" on the back of the SLEB.

-Connect the cable on the Starters' Console into the port marked "CONTROL BOX" on the back of the SLEB.

-The cable for connecting the SLEB to the start line photocells is a pre-marked fanned cable. Connect the start line photocell cable into the port marked "PHOTOCELLS" on the back of the SLEB.

#### **EMERGENCY**

Push the EMERGENCY button on the front panel of the C-33. Check to make sure that the red tree light comes on and that the C-33 screen shows the emergency sign. Reset the timer. Check the EMERGENCY switch on the Starters' Console. The EMERGENCY button on the C-33 and EMERGENCY button on the Starters' Console must be off to reset the timer.

Switch both to EMERGENCY mode. Test to be sure that the starters' console cannot reset the tree while the emergency light is on. Turn off the EMERGENCY switch on the Starters' Console. Now test the C-33 to make sure it cannot reset the timers. Now turn both switches off and check to be sure the timer can be reset by both the C-33 and the Starters' Console.

### **2.7.3    START LINE PHOTOCELL CHECK (USING BUILT-IN C-33 FUNCTION)**

Use the photocell check function that is built into the C-33 to check the operation of the start line photocells. See Section 3.2.11 of this manual for instructions on the use of the photocell check function. Also see Section 2.9 for instructions on sighting photocells.

#### **2.7.4     TIMER - INTERMEDIATE PHOTOCELL CHECK**

Connect the cable for the finish line port on the back of the C-33. Now test the operation of the intermediate photocells and light sources. Use the photocells check function as in Section 2.7.3.

#### **2.7.5     TIMER - FINISH LINE - WIN LIGHTS**

##### **Finish Line Electronics Box (See Figure 13)**

-Connect the FLEB into the finish line outlet.

-The cables which connect the FLEB and the right and left speed trap and finish line photocells are fanned cables. Connect the cable for the right photocells into the port marked "PHOTOCELLS RIGHT". Connect the cable for the left photocells into the port marked "PHOTOCELLS LEFT".

-Connect the cable coming from the left and right win lights into the ports marked "WIN LIGHTS RIGHT AND LEFT".

-Connect the cable that runs to the tower into the port marked "TOWER".

##### **Win Lights**

Use the WIN LIGHTS DIAGNOSTICS function that is built into the C-33 to test the optional win lights and judge system. See Section 3.3.2.9 for instructions on the use of the WIN LIGHTS DIAGNOSTICS function.

#### **2.7.6     FINISH LINE PHOTOCELL CHECK**

Use the photocell check function again to check the operation of the finish line photocells. Now all photocells should be operational.

#### **2.7.7     PRINTERS**

Make sure both printers are on and "ONLINE". Check to be sure both toggle switches on the front C-33 panel for the printers are both on. Run an example race with a car or just a person blocking the photocells. Make sure both printers are working properly.

### **2.7.8 SCOREBOARDS (OPTIONAL) (BUILT-IN C-33 FUNCTION)**

If scoreboards are being used, there are two ways connections can be made depending on what type of displays are being used.

1. For the ES18 or MS18 scoreboards, a direct connection between the display driver and the tower junction box is made. These cables are typically run in conduit with the finish line cable.
2. For the "CH" line of scoreboards such as the CH-536DS a display interface is used. See the interface users manual for connections between the interface and the displays. These wires are run with the finish line wires in the conduit.

Use the SCOREBOARD DIAGNOSTICS function that is built into the C-33 to test the operation of the scoreboards. See Section 3.3.2.8 for instructions on the use of the SCOREBOARD DIAGNOSTICS function.

### **2.7.9 FINAL TESTING**

Finally, drive a car down the track at constant speed and check the operation of the entire system. Verify the accuracy of the times that are returned as well as the speeds.

## **2.8 TRACK WITH EXISTING SYSTEM**

### **2.8.1 CONNECTOR SET TO TIE NEW SYSTEM TO OLD SYSTEM CABLE**

Use the connector set to adapt the tracks' current cables to cables that will connect to the new equipment.

### **2.8.2 NEW EQUIPMENT**

See the following sections for instructions on connecting the new equipment for the track:

<u>SECTION NO.</u>	<u>DESCRIPTION</u>
2.6.1.1	Tower Junction Box
2.6.1.2	Tower Junction Box to Start Line Junction Box Wiring
2.6.2	Start Line Electronics Box
2.7	Operational Check

## 2.9 SIGHTING THE PHOTOCELLS

SET-UP STEPS (Please refer to the figure on the following page):

1. Turn on the C-33 timer to power the photocell signal lines.
2. Turn on the light source.
3. Sight in the photocell at the light source so the best lens reflection will be obtained. Looking directly over the top of the light source, you will see a bright lens reflection when the light beam strikes it. It may be desirable to block light sources at the start line that are not being sighted.
4. Use the sighting cap on top of the barrel to view inside the photo-pickup (see next page). Locate and center the bright spot on the back plate of the photo-pickup. Make sure the beam is sharply focused to an approximate beam diameter of 1/8th of an inch. If the beam is not sharp, the photocell may not be centered on the light source. Also, the lamps should have a unpainted band that should be perpendicular to the track surface.
5. Adjust the position of the photo-pickup so that the bright spot falls EXACTLY on the photocell element in the center of the back plate. **CAUTION: BE CAREFUL TO PUT THE CAP BACK INTO PLACE SO THE SIGHTING IS NOT ALTERED.**

### ELECTRICAL TEST:

1. Connect a volt-ohm meter (1000 ohm / volt or better) as shown on the next page, clipping the black lead to the spring on the back of the photocell connector and clipping the red lead on the bare section of the positive lead (smooth wire).  
**NOTE:** Newer model photo-pickups will include a test meter "banana" jack near the photocell connector. This eliminates the need to strip a section of the positive lead for testing.
2. The meter should read near zero with the light entering the photo-pickup. When you hold your hand in front of the photo-pickup to darken it, the meter should read near +12 Volts DC.
3. The photocell check function should be used to check the alignment of the photocells after sighting (see Section 3.2.11 for details).

PHOTOCELL

CONNECT BLK (-) LEAD OF THE  
VOLT METER TO THE BLK JACK  
CONNECT RED (+) LEAD OF THE  
VOLT METER TO THE RED JACK

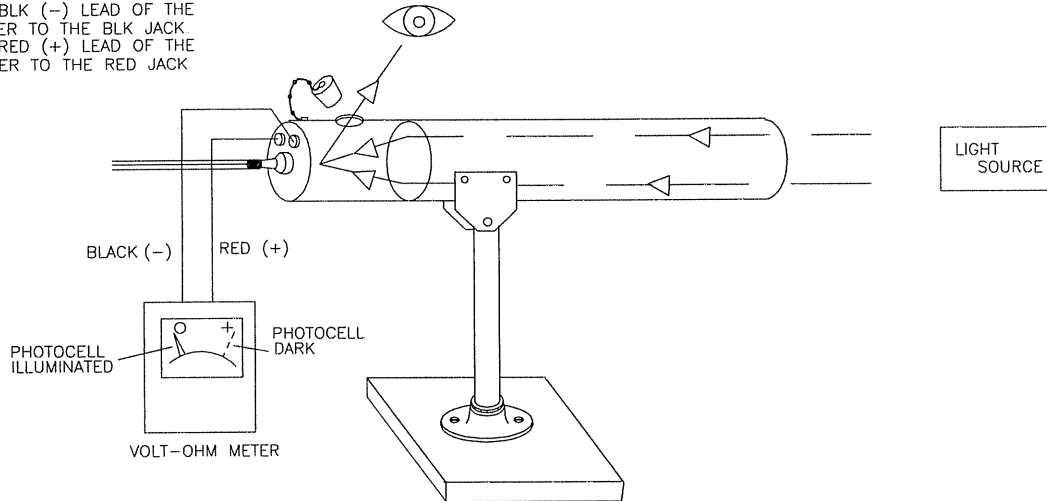

ALTERNATE METER HOOK-UP

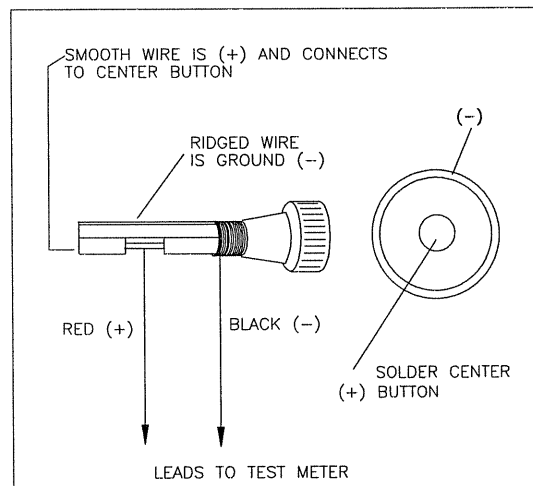

FIGURE 15.0



## 3. OPERATION OF THE C-33 RACE TIMER

### 3.1 GENERAL OPERATION

Access to all of the race controller's functions are through the FUNCTION KEYS (F1 through F10) located on the left side of the keyboard and the front panel switches. Many of the function keys have more than one purpose which are accessed by using the function keys in conjunction with the SHIFT, CTRL, or ALT keys. A table of all functions is given in Section 3.3.1 of this manual, or can be called up from the race controller by pressing the F10 key (HELP SCREEN).

Keystroke sequences associated with functions are given in parentheses throughout the manual. If a function key is listed by itself, such as (F1), that means that the F1 key alone is used to access that function. If a function key is listed with another key, such as (SHIFT F1), the SHIFT key must be **held down** while the F1 key is momentarily depressed.

#### 3.1.1 ENTERING DIAL-INS

Entering dial-ins on the C-33 is much like entering numbers on a calculator. Just type in the number, leading and trailing 0's are put in automatically. However, the decimal point must be entered by the user. There is also a maximum of 2 digits before and after the decimal point. After entering the dial-in press the <ENTER> key.

C33 TIMER

C33 BACK PANEL

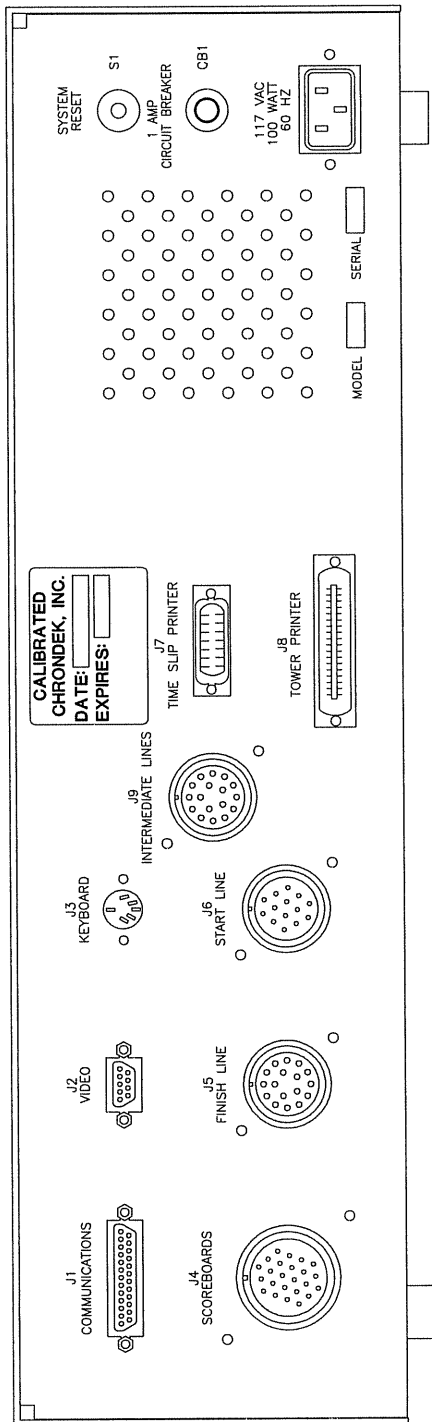

OVERALL SIZE  
20-1/2" X 13" X 7"  
(L X W X H)

POWER  
117 VAC 50/60 HZ  
100 WATTS

C33 FRONT PANEL

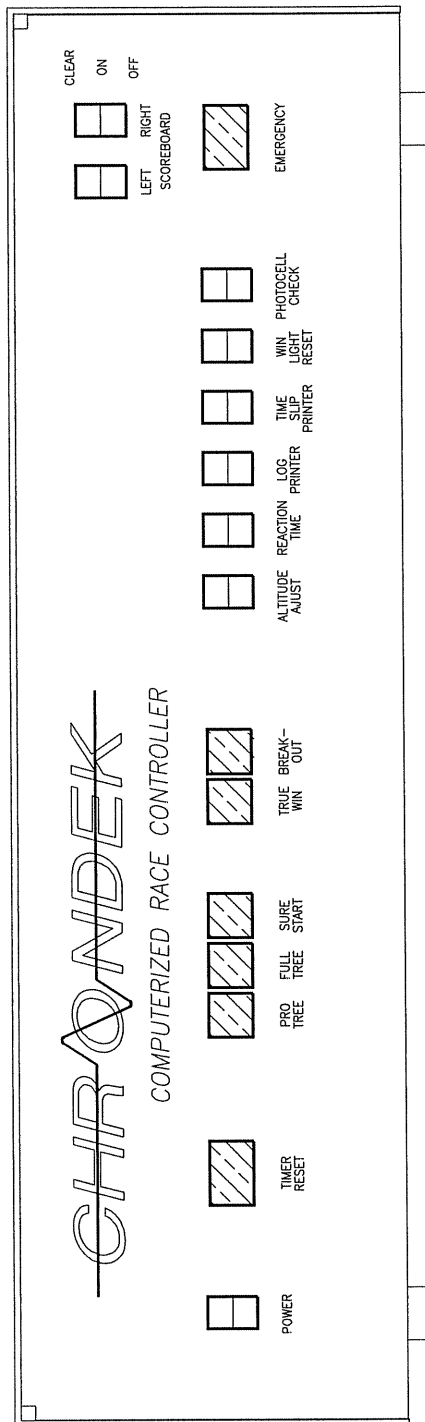

FIGURE 16.0

## 3.2 C-33 RACE CONTROLLER FUNCTIONS

### 3.2.1 POWER BUTTON

On the front of the C-33 race controller are several lighted push-buttons and switches (See Figure 16) which determine how the controller is to function. On the far left is the POWER button used to supply main power to the unit. When the unit is connected to a proper power source and the switch is on, the switch will be illuminated.

When the system is powered up, the monitor should display the following screen (See Figure 17). (Note: Your system may be configured differently when you power up the C-33, therefore your screen may show some subtle differences to the one below. It should, however, be very close.)

**FIGURE 17 C-33 MAIN SCREEN**

CHRONDEK C33 TIMER (C) 1993 V6.0		17:21:58
<p style="text-align: center;">LEFT LANE</p> <p>SF1 Vehicle #:  SF5 Driver :  SF3 Dial-In : .00 Hdcp: .00  Reaction Time:  Interim1 Time: Int3:  Interim2 Time: Int4:  Elapsed Time :  Speed (MPH) : 1/8M:  Over/Under(-):</p> <p style="text-align: center;"><b>TIMER RESET</b></p> <p>F1 Next Veh # :  F5 Next Driver:  F3 Next Dl-in : .00</p>	<p style="text-align: center;">RIGHT LANE</p> <p>SF2 Vehicle #:  SF6 Driver :  SF4 Dial-In : .00 Hdcp: .00  Reaction Time:  Interim1 Time: Int3:  Interim2 Time: Int4:  Elapsed Time :  Speed (MPH) : 1/8M:  Over/Under(-):</p> <p style="text-align: center;"><b>TIMER RESET</b></p> <p>F1 Next Veh # :  F6 Next Driver:  F4 Next Dl-in : .00</p>	
PS SG GD I1 I2 1S I3 1E I4 SS ET SE    PS SG GD I1 I2 1S I3 1E I4 SS ET SE		
.4 SEC PRO (3AMB)            ADJ #1 ET = 1.0000 SPD = 1.0000		
LOG=OFF    TIME SLIP=OFF		
<F9>Ready    <F10>Help    <Ctrl-F1>Setup Menu    <Ctrl-F7>Reset    <Ctrl-F8>Print		

### **3.2.2 TIMERS RESET**

Next to the POWER switch is the green TIMERS RESET button. This button is used to reset the timers for both lanes. When both timers are reset, the TIMERS RESET button on the C-33 and a "timers reset" light on the starter's console will be illuminated, and a TIMER RESET message will appear for each lane on the monitor.

### **3.2.3 TREE COUNTDOWN MODES**

The next two buttons to the right are the PRO TREE and the FULL TREE buttons. When the PRO TREE button is pressed, it will illuminate and the Christmas tree will be in a PRO countdown mode. When the FULL TREE button is pressed, it will illuminate and the Christmas tree will be in a FULL countdown mode. The exact countdown sequence and countdown rate used is selected by pressing (CTRL F1) to get the "Setup Parameters" menu, followed by (C) to access the "Tree Countdown Mode" feature (see Section 3.3.2.2).

The countdown sequence and rate that are currently active are displayed in the lower center portion of the main screen. This gives the operator constant verification of the countdown mode.

### **3.2.4 SURE START**

Next to the tree countdown mode buttons is the blue SURE START button. Pressing this button will put the timer in SURE START mode. When in this mode, a foul will be generated if a vehicle was not pre-staged at the instant the starter's switch was thrown to "go". This feature allows a track operator to enforce the "no deep staging" rule.

When SURE START is activated, the blue bulb on the Christmas tree between the stage lights will be on. If the button is pushed a second time, the sure start is turned off and the blue bulb is no longer illuminated.

### **3.2.5 TRUE WIN/BREAKOUT**

The TRUE WIN button illuminates when pressed indicating that the TRUE WIN function is active. This allows the winner of a race to be determined based on the following factors:

### 3.2.5 TRUE WIN/BREAKOUT (CONTINUED)

1. General disqualifications (entered manually by the operator).
2. Crossing a lane boundary line (entered manually by the operator).
3. A foul (red light).
4. Crossing the finish line first.
5. Not finishing the course (entered manually by the operator).

If TRUE WIN is activated, the BREAKOUT function can be activated. Pressing this button allows the inclusion of E.T. breakouts into the determination of a winner. When both TRUE WIN and BREAKOUT are activated, the following factors are used to determine the true winner:

1. General Disqualifications (DSQ). Disqualifications are infractions manually entered by the operator (ALT-F1 or ALT-F2) such as: unsportsmanlike conduct, intentional delay of run, and others as determined by the officials. The C-33 handles DSQ's in the following way: If one driver is disqualified, the other driver automatically receives the win. If both drivers are disqualified, the driver with the least severe infraction wins the race. To determine the severity of an infraction, see the race officials.

2. Crossing Lane Boundary Lines (OB). Leaving lane boundary lines is an infraction of the rules. If the operator is notified that a driver has left the driving lane, the operator enters an out-of-bounds (OB) (ALT-F3 or ALT-F4). The driver who leaves the driving lane is disqualified, the other driver automatically wins even if his or her car leaves the driving lane during the remainder of the race unless a more severe infraction occurs.

3. Fouls (red lights). A foul or "red light" is caused when a driver crosses the starting line before the green light is on (negative reaction time). The C-33 automatically senses if a foul has occurred. When a foul does occur, the driver who fouled is disqualified and the other driver receives the win. If both drivers foul, the driver who fouled first loses the race.

4. E.T. breakouts. A breakout occurs when the driver beats his or her respective dial-in. The C-33 automatically detects breakouts. When a breakout occurs, the driver who "broke-out" is disqualified and the other driver receives the win. If both drivers breakout, the driver who "brokeout" by the least amount of time receives the win. If both breakouts are equal the driver that crossed the finish line first is the winner.

### **3.2.5 TRUE WIN/BREAKOUT (CONTINUED)**

5. Which vehicle crossed the finish line first. The C - 3 3 automatically determines which driver finishes the race first. This determination is used to determine the winner when two drivers have equal dial-ins and no other infractions occur, or when an double breakout of equal time occurs.

6. Not finishing the course (DNF). If a driver does not finish the course, the C-33 operator manually enters a did-not-finish (DNF) (ALT-F5 or ALT-F6). The driver who did not finish the race loses the race. If both drivers do not finish both drivers are given losses.

Both TRUE WIN and BREAKOUT are deactivated by pressing the buttons a second time.

### **3.2.6 EMERGENCY**

At the extreme right side of the panel is the red EMERGENCY switch. Pressing this switch will activate the flashing red lights on the tree and inhibit any countdown of the tree. The EMERGENCY button will also flash an emergency message on the monitor. Pressing the button a second time will deactivate emergency mode.

There is also an emergency switch on the starter's console (See Figure 18) which will also activate emergency mode. Both the switch on the C-33 and the switch on the control box must be off to deactivate the emergency mode.

### **3.2.7 ALTITUDE ADJUSTMENT**

#### **3.2.7.1 AN INTRODUCTION TO ALTITUDE ADJUSTMENT**

Many race car engines run better and the cars consequently move faster, when the air needed by the engine is denser. In general, cars will run faster at sea-level tracks than at high elevation tracks such as in "mile high" Denver. The drag racing industry has developed lists of "altitude correction" factors that can be used to adjust E.T. and MPH values for races that are run at various altitudes. The basic concept is to adjust the E.T. and MPH values that are experienced at the higher elevation tracks to "sea-level" values so that all results can be directly compared.

STARTER'S CONSOLE

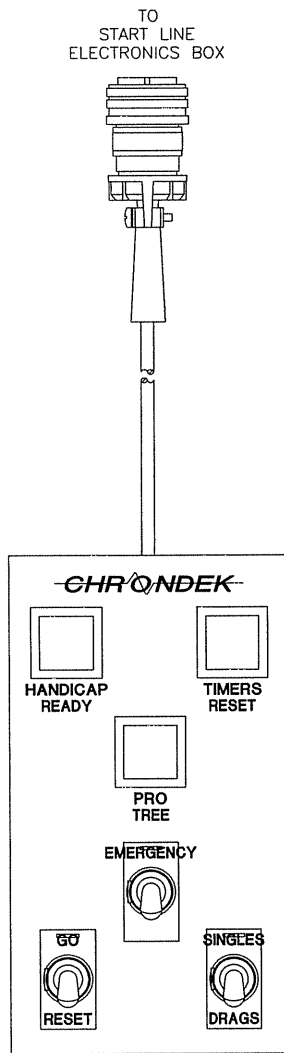

BOX SIZE  
 $3\text{-}1/4" \times 5\text{-}3/4" \times 2"$   
(L X W X H)

FIGURE 18.0

### 3.2.7.1 AN INTRODUCTION TO ALTITUDE ADJUSTMENT (CONTINUED)

In the past, the E.T. and MPH values had to be manually adjusted using the altitude correction factor when preparing a timer for a race or verifying the results. The "altitude adjustment" feature of the C-33 timer allows this operation to be performed automatically by the timer to prevent errors and allow quicker verification of race results. The C-33 also allows the automatic altitude adjustment function to be quickly switched off if manual calculations are desired or if the altitude correction factors are not used for some races.

The C-33 system allows three sets of adjustment factors to be entered by the operator. Each set contains one factor for adjusting the E.T. and one factor for adjusting the MPH. This allows different categories of classes to have different adjustment factors pre-entered and quickly available for each race. The determination and accuracy of the actual factors used are the responsibility of the track operator and the tracks' sanctioning body.

### 3.2.7.2 ALTITUDE ADJUSTMENT EXAMPLE

Figure 19 shows the results of a race that was run using the altitude adjustment factors of the C-33.

#### NOTES ON FIGURE 19:

1. Notice at the bottom of the screen:
  - Altitude adjustment feature is turned on ("ADJ").
  - Adjustment factor set #1 is selected.
    - This factor set has an E.T. factor = 0.9850 and speed factor = 1.0150.
2. Dial-Ins for the two drivers were entered as "sea-level" dial-ins. Dial-Ins of 10.25 for the left lane and 10.17 for the right lane were entered.



Figure 19. Altitude Adjustment Example

CHRONDEK C33 TIMER (C) 1991 V4.1		17:21:58
LEFT LANE	RIGHT LANE	
SF1 Vehicle #: 245 SF5 Driver : SPENSER SF3 Dial-In : 10.25 Hdcp: 10.41 Reaction Time: 0.172 Interim1 Time: 1.172 Int3: 7.412 Interim2 Time: 6.891 Int4: 9.321 Elapsed Time : 10.311 Speed (MPH) : 91.43 1/8M: 85.42 Over/Under(-): .061  F1 Next Veh # : F5 Next Driver: F3 Next Dl-in : .00	SF2 Vehicle #: 248 SF6 Driver : ANDERSON SF4 Dial-In : 10.17 Hdcp: 10.32 Reaction Time: 0.113 Interim1 Time: 1.347 Int3: 7.213 Interim2 Time: 6.673 Int4: 9.118 Elapsed Time : 10.262 Speed (MPH) : 93.68 1/8M: 86.21 Over/Under(-): .092  *WIN* <1ST> F1 Next Veh # : F6 Next Driver: F4 Next DL-in : .00	
PS SG GD I1 I2 1S I3 1E I4 SS ET SE		PS SG GD I1 I2 1S I3 1E I4 SS ET SE
.4 SEC PRO (3AMB)		ADJ #1 ET = 0.9850 SPD = 1.0150
LOG=ON TIME SLIP=ON		
<F9>Ready <F10>Help <Ctrl-F1>Setup Menu <Ctrl-F7>Reset <Ctrl-F8>Print		

### 3.2.7.2 ALTITUDE ADJUSTMENT EXAMPLE (CONTINUED)

3. The C-33 automatically divides the "sea-level" dial-in by the E.T. adjustment factor to produce an actual (at altitude) elapsed time value that will be used to determine the tree handicap. This "AT ALTITUDE" elapsed time value is shown on the screen after the word "Hdcp" for each lane.
4. As the race is run, the C-33 multiplies the actual measured "AT ALTITUDE" times by the E.T. adjustment factor to produce the "sea-level" times for:
  - Reaction Time
  - Interim 1 Time
  - Interim 2 Time
  - Final E.T.
5. The actual "AT ALTITUDE" MPH which is calculated in the speed trap by the C-33 is multiplied by the MPH adjustment factor to produce "sea-level" MPH.
6. Note that all the times and MPH shown on the monitor, scoreboard, and printouts are "sea-level" values. Most drivers and spectators are familiar with the sea-level values which are also listed in most racing publications.
7. Note that the values in the E.T. printout (Figure 20) are marked with "A1" to show that they are sea-level values that have been calculated from the actual "AT ALTITUDE" values using altitude adjustment factor #1. This is also true for the log slip (See Figure 21).

Figure 22 shows the results of an identical race that was run without using the altitude adjustment feature.

Note that the dial-ins were manually adjusted before being entered. The times and MPH shown are the actual "unadjusted" AT ALTITUDE values that were read by the C-33 timer.

Figure 20. Time Slip Printout Showing Adjustment Factors

---

WELCOME TO THUNDER VALLEY'S 1989 FINALE  
"\$1,000 BRACKET BONANZA BASH"  
**TASTE IT NOW? BUDWEISER AND PEPSI-COLA**  
THANKS FIRESTONE / CENTERLINE E.T. RACING SERIES

MAY 12, 1991 16:48

	LEFT LANE		RIGHT LANE
	<b>245</b>		<b>248</b>
Dial-in :	10.25		Dial-in : 10.17
Reaction:	0.172		Reaction: 0.113
60 FT :	1.172 <A1>		60 FT : 1.347 <A1>
320 FT :	6.891 <A1>		320 FT : 6.673 <A1>
660 FT :	7.412 <A1>		660 FT : 7.213 <A1>
MPH(660):	85.42 <A1>		MPH(660): 86.21 <A1>
990 FT :	9.321 <A1>		990 FT : 9.118 <A1>
E.T. :	10.311 <A1>		E.T. : 10.262 <A1>
MPH :	91.43 <A1>		MPH : 93.68 <A1>
Over/Under:	.061		Over/Under: .092
			<b>WIN &lt;1ST&gt;</b>

---

Figure 21. Log Printout showing Adjustment Factors

---

L16:48	245	DI=10.25	RT=0.172	I1=1.172	I2=6.891	I3=7.412	S1=84.42	I4=9.321	
									ET=10.311 SP=91.43 WIN <1ST>
									A1
R16:48	248	DI=10.17	RT=0.113	I1=1.347	I2=6.673	I3=7.213	S1=86.21	I4=9.118	
									ET=10.262 SP=93.68
									A1
		FULL	S.S.-N	T.W.-Y	B.O.-N				

---

Figure 22 Identical race to that shown in Figure 20 but without alt. adj. feature

CHRONDEK C33 TIMER (C) 1991 V4.1		17:21:58
LEFT LANE	RIGHT LANE	
SF1 Vehicle #: 245 SF5 Driver : SPENSER SF3 Dial-In : 10.415 Reaction Time: 0.172 Interim1 Time: 1.190 Int3: 7.525 Interim2 Time: 6.996 Int4: 9.463 Elapsed Time : 10.468 Speed (MPH) : 90.08 1/8M: 85.16 Over/Under(-): .058  F1 Next Veh # : F5 Next Driver: F3 Next Dl-in : .00	SF2 Vehicle #: 248 SF6 Driver : ANDERSON SF4 Dial-In : 10.32 Reaction Time: 0.113 Interim1 Time: 1.368 Int3: 7.323 Interim2 Time: 6.775 Int4: 9.257 Elapsed Time : 10.418 Speed (MPH) : 92.30 1/8M: 84.94 Over/Under(-): .098  *WIN* <1ST> F1Next Veh # : F6 Next Driver: F4 Next Dl-in : .00	
PS SG GD I1 I2 1S I3 1E I4 SS ET SE	PS SG GD I1 I2 1S I3 1E I4 SS ET SE	
.4 SEC PRO (3AMB)	ADJ #1 ET = 0.9850 SPD = 1.0150	
	LOG=ON TIME SLIP=ON	
<F9>Ready <F10>Help <Ctrl-F1>Setup Menu <Ctrl-F7>Reset <Ctrl-F8>Print		

A sometimes confusing effect of altitude adjustment corrections on handicap calculations can also be shown with this example.

If the cars had been racing at an actual sea-level track with dial-ins of 10.25 and 10.17 respectively, the handicap would be 10.25 - 10.17 = 0.08 seconds. The concept of altitude corrections assumes that both cars in the race will be affected to the same percentage by the thinner air AT ALTITUDE. Thus, both cars E.T.'s are adjusted by the same altitude factor. The "at altitude" E.T.'s are thus 10.41 and 10.32 respectively.

### 3.2.7.2 ALTITUDE ADJUSTMENT EXAMPLE (CONTINUED)

A fair race based on the altitude corrections concept, therefore, requires that the resulting handicap at altitude will be  $10.41 - 10.32 = 0.09$  seconds.

### 3.2.7.3 USING ALTITUDE ADJUSTMENT

To set the Race Controller for altitude adjustment, set the ALTITUDE ADJUSTMENT switch on the front panel to the "on" position.

Once the factor sets have been preset (see Section 3.3.2.1), they can be selected by pressing (CTRL F9). The current selection of adjustment factors is displayed on the monitor. Also, an A1, A2, or A3 will be printed on the time slip to indicate which adjustment factor set has been selected.

### 3.2.7.4 USING DIAL-INS WITH ADJUSTMENT FACTORS

When a dial-in is entered, it is assumed to a 'sea-level' dial-in. This usually comes from a published index or, in the case of E.T. racing, from the time slip of an earlier altitude adjusted time trial run.

For the tree handicap countdown, the 'sea-level' dial-in that is entered for each lane is divided by the current E.T. adjustment factor to give the proper handicap difference based on the two cars performance AT ALTITUDE. This insures a properly matched handicap race. Since the E.T. used to determine breakouts is a "sea-level" E.T., it is compared to the "sea-level" dial-in to determine if a breakout has occurred.

**NOTE:** The system does not allow any dial-in's greater than 99.99. Therefore, if an adjusted dial-in figures to be greater than 99.99, the originally entered dial-in will be used for the tree handicap.

### 3.2.8 REACTION TIMER

This switch allows reaction times to be printed on the time slips. (Reaction times are **always** displayed on the screen and printed on the log printer, despite the position of the reaction timer switch).

All reaction times are calculated from the start of the green light. A "perfect" reaction time would register as "0.000". Negative or "red light" reaction times are calculated "backwards" from the beginning of the green light and are displayed as negative numbers. If a vehicle leaves the starting line .001 seconds before the green light, the reaction timer would read "-.001".

### **3.2.9 PRINTERS**

The LOG PRINTER and TIME SLIP PRINTER switches enable and disable the log and time slip printers. If a printer is turned off or not ready, the monitor will display a message to that effect in the lower right hand corner of the screen. If a printer is off, the C-33 race controller will store a limited number of race results (approximately 15). When the printer is once again enabled, the stored information will automatically print out.

### **3.2.10 RESET WIN LIGHT**

This switch will turn off all of the spectator win lights on the finish line scoreboards. These lights will also automatically turn off after a preset amount of time. This preset amount of time (selected manually by the operator) is called the WINLIGHT TIMEOUT (W on the parameter setup menu, see Section 3.3.2.7). The WINLIGHT TIMEOUT can be set to either 15, 30, or 45 seconds. The default time is 45 seconds.

### **3.2.11 PHOTOCELL CHECK**

The photocell check switch will work only while the timer is in RESET mode. This check makes the photocells less sensitive in order to verify that the cells are properly aligned.

If all the photocells are aligned properly, the letters denoting each cell will disappear from the bottom of the screen. If a cell is not properly aligned or it is not working properly (i.e. the cell is not receiving power, or the light source bulb is burned out) the letters for that cell will stay on the screen. If this occurs, these particular cells should be checked before the system is used.

### 3.3 ADDITIONAL FUNCTIONS

#### 3.3.1 HELP SCREEN

The following illustration depicts the HELP SCREEN that is called up on the monitor when (F10) is pressed. This page should be used as a quick reference to various C-33 functions.

**IT IS RECOMMENDED THAT THIS PAGE BE REPRODUCED AND POSTED FOR THE OPERATORS USE.**

Additional function descriptions appear on the following pages.

<F1>	L Next Vehicle Number	<F2>	R Next Vehicle Number
<F3>	L Next Driver's Name	<F4>	R Next Driver's Name
<F5>	L Next Dial-In	<F6>	R Next Dial-In
<F7>		<F8>	
<F9>	Handicap Ready	<F10>	Help
<SHIFT F1>	L Vehicle Number	<SHIFT F2>	R Vehicle Number
<SHIFT F3>	L Driver's Name	<SHIFT F4>	R Driver's Name
<SHIFT F5>	L Dial-In	<SHIFT F6>	R Dial-In
<SHIFT F7>		<SHIFT F8>	
<SHIFT F9>	Move L Next To Current	<SHIFT F10>	Move R Next To Current
<ALT F1>	Disqualified	<ALT F2>	R Disqualified
<ALT F3>	L Out Of Bounds	<ALT F4>	R Out Of Bounds
<ALT F5>	L Did Not Finish	<ALT F6>	R Did Not Finish
<ALT F7>		<ALT F8>	
<ALT F9>	Cancel Left Infractions	<ALT F10>	Cancel Right Infractions
<CTRL F1>	Setup Parameters	<CTRL F2>	
<CTRL F3>	Get L Next From CARS	<CTRL F4>	Get R Next From CARS
<CTRL F5>	Swap L and R lanes	<CTRL F5>	Select Active Ajust Factor
<CTRL F7>	Reset Timers/Next	<CTRL F8>	Print/(Reset/Next)
<CTRL F9>		<CTRL F10>	

PRESS ANY KEY TO RETURN TO MAIN SCREEN

FIGURE 23 C-33 HELP SCREEN

### 3.3.1.1 DEFAULT VALUES

When the C-33 is first powered up, the system defaults to the following values:

Pro Tree = .4 second 3 amber  
Full Tree = .5 second 3 amber  
All Altitude Adjustment Factor Values = 1.0000  
Active Altitude Adjustment Factor Set = 1

E.T. Scoreboard = RT off I1 off I2 off I3 off I4 off ET on

Speed Scoreboard = DI on S1 off SP on

Time Slip Format = 2 dual lane time slips

These values can be changed using the "Setup Parameters" menu (CTRL F1).

### 3.3.2 SETUP PARAMETERS MENU

The Setup Parameters Menu (CTRL F1) is used to configure the system before racing begins. Following is a description of each of the options in the menu.

#### 3.3.2.1 (A) ALTITUDE ADJUSTMENT FACTORS

ALTITUDE ADJUSTMENT:	#1	#2	#3
E.T. -->	1.0000	1.0000	1.0000
SPEED -->	1.0000	1.0000	1.0000

Press <TAB> or <ENTER> to MOVE to next item  
Press <ESCAPE> to EXIT to Setup Menu

The (A) option on the Setup Parameters Menu is chosen when Altitude Adjustment factors will be used. Type in the E.T. factor for the first set in a fixed decimal point format. BE CAREFUL - be sure the factor is entered correctly (i.e. make sure the E.T. factor is entered as 0.9xxx and not as 9.xxxx). By using the space bar and backspace key, the operator can move around within the factor itself to make sure it is correct.

There are three sets of adjustment factors available, each set containing one (1) factor for adjusting the E.T.'s and one (1) factor for adjusting the speed.



### 3.3.2.1 ALTITUDE ADJUSTMENT FACTORS (CONTINUED)

Switching among the sets is easily accomplished by the operator. When the first factor is correctly entered, use the tab or enter key to move to the E.T. factor for the next set.

Continue to make entries until all the desired factors have been entered. If no entry is needed, just use the tab key to move to the next factor. NOTE: Although three sets of factors are available, it is not necessary to use them all. If only one set is needed, just enter that set and leave the others alone.

When all factors have been entered, press the <ESC> key to return to the Setup menu.

### 3.3.2.2 (C) TREE COUNTDOWN MODES

COUNTDOWN:	SEQUENCE	RATE
PRO TREE -->	PRO (3 AMB)	.4 SEC
FULL TREE -->	3 AMBER	.5 SEC

Press <SPACE BAR> to CHANGE item  
Press <TAB> or <ENTER> to MOVE to Next Item  
Press <ESCAPE> to EXIT to Setup Menu

There are many possible combinations of sequences and rates of countdown for the tree. The following is a list of available sequences and rates. **They can be used in any combination.**

#### Pro Tree

<b>Sequences</b>	<b>Rates</b>
Instant Green	.2 sec
Pro (1 amber)	.3 sec
Pro (3 amber)	.4 sec
	.5 sec

#### Full Tree

<b>Sequences</b>	<b>Rates</b>
2 amber	.2 sec
3 amber	.3 sec
5 amber	.4 sec
	.5 sec

### 3.3.2.3 (D) FINISH LINE DISTANCE

```
FINISHLINE DISTANCE IS SET TO 1/4 MILE  
  
PRESS <SPACE BAR> TO CHANGE ITEM  
PRESS <ESCAPE> TO EXIT TO SETUP MENU
```

Option (D) is used to change the Finishline location on the track. The user has two choices to choose from:

1/4 MILE (Default)  
1/8 MILE

NOTE: To use this option, the track must have two photocell boards and all interim photocells in place.

### 3.3.2.4 (E) EVENT AND SPONSOR INFORMATION

```
Track Name (79 characters max.):  
  
Event Name (79 characters max.):  
  
Sponsor Ad line 1 (40 characters max.):  
  
Sponsor Ad line 2 (40 characters max.):  
  
Press <TAB> or <ENTER> to MOVE to Next Item  
Press <ESCAPE> to EXIT to Setup Menu
```

From this menu, the track name, event name, and two sponsor ad lines are entered.

All information entered in this fashion will be printed on each time slip. An example of the time slip printout can be seen in Figure 21.

### 3.3.2.5 (F) TIME SLIP FORMAT

```
PRINT TWO DUAL LANE TIME SLIPS  
  
Press <SPACE BAR> to CHANGE Item  
Press <ESCAPE> to EXIT to Setup Menu
```

### 3.3.2.5 (F) TIME SLIP FORMAT (CONTINUED)

Option (F) is used to change the format of the time slips. The user has three formats to choose from:

PRINT TWO DUAL LANE TIME SLIPS (default)  
PRINT TWO SINGLE LANE TIME SLIPS  
PRINT ONE DUAL LANE TIME SLIP

### 3.3.2.6 (S) SET SCOREBOARD ENABLES

Two Line Scoreboard Enables

E.T. SCOREBOARD						SPEED SCOREBOARD		
-----						-----		
RT	I1	I2	I3	I4	ET	DI	S1	SP
N	N	N	N	N	Y	Y	N	Y

NUMBER OF ET DIGITS TO SHOW 4 DIGITS

Press <SPACE BAR> to CHANGE Item  
Press <TAB> or <ENTER> to MOVE to Next Item  
Press <ESCAPE> to EXIT to Setup Menu

One Line Scoreboard Enables

SINGLE LINE SCOREBOARD										
-----										
RT	I1	I2	I3	I4	ET	DI	S1	SD	BRT	HOLD-TIME
N	N	N	N	N	Y	Y	N	Y	Y	3 SECS

NUMBER OF ET DIGITS TO SHOW 4 DIGITS

Press <SPACE BAR> to CHANGE Item  
Press <TAB> or <ENTER> to MOVE to Next Item  
Press <ESCAPE> to EXIT to Setup Menu

### 3.3.2.6 (S) SET SCOREBOARD ENABLES (CONTINUED)

Option (S) is used to configure the displays. The two scoreboard switches (located in the upper right hand corner of the console), one for each lane of the drag strip, enable or disable the two scoreboards located at the finish line.

If the switch is in the down or OFF position, the scoreboard for that lane is disabled and nothing is displayed. If the switch is in the middle or ON position, the scoreboard is active and will automatically display the information that has been enabled. If the switch is pressed into the clear or up position (it will not stay in this position), the scoreboard information will be immediately erased.

A particular time or value will be displayed only when a "Y" appears below it on the set scoreboard enables screen. Move the highlight bar to the value that needs to be changed and press the space bar. The display will alternate between "Y" and "N". The default values appear above. See Section 4.4, switches 1-7 and 1-8 for more information.

### 3.3.2.7 (T) SYSTEM TIME AND DATE

```
Enter System time (hh:mm:ss):  
17:21:53  
  
Enter Date:  
  
Press <TAB> or <ENTER> to MOVE to Next Item  
Press <ESCAPE> to EXIT to Setup Menu
```

Current system time and date must be entered using this option to insure that all printouts have accurate time and dates.

### 3.3.2.8 (W) WIN LIGHT FORMAT

```
WIN LIGHT TIMEOUT IS SET TO 45 SECONDS  
  
Press <TAB> or <ENTER> to MOVE to Next Item  
Press <ESCAPE> to EXIT to Setup Menu
```

The win light timeout can be set to either 15, 30, or 45 seconds. The default time is 45 seconds.

### 3.3.2.9 (CTRL-S) SCOREBOARD DIAGNOSTICS

```
RUNNING SCOREBOARD DIAGNOSTICS

LEFT E.T.          --> 96.71
LEFT SPEED         --> 896.73
RIGHT E.T.         --> 97.35
RIGHT SPEED        --> 859.37

PRESS ANY KEY TO STOP DIAGNOSTICS
```

To activate the Scoreboard Diagnostics program press CTRL-S. The screen will show the numbers that are being sent to the respective fields on the scoreboard. If there are parts of a number that are not lighting, either a bulb has to be replaced or scoreboard is not functioning properly. See the scoreboard users manual for instructions on troubleshooting the scoreboard.

### 3.3.2.10 (CTRL-W) WIN LIGHT DIAGNOSTICS

```
RUNNING WIN LIGHT DIAGNOSTICS

SEQUENCE:
1. LEFT TRUE WIN & LEFT JUDGE
2. LEFT 1ST FINISH
3. LEFT BREAKOUT
4. LEFT FOUL
5. RIGHT TRUE WIN & RIGHT JUDGE
6. RIGHT 1ST FINISH
7. RIGHT BREAKOUT
8. RIGHT FOUL

PRESS ANY KEY TO STOP WIN LIGHT DIAGNOSTICS
```

The Win Light Diagnostics program can be activated by pressing CTRL-W. The screen will show the sequence that the Win Lights should follow when they light. If a Win Light does not light, either a bulb has to be replaced or the win lights are not functioning properly. See the scoreboard users manual for instructions on troubleshooting the scoreboard.

### 3.3.3.11 (CTRL-R) SOFT RESET FUNCTION

Refer to Section 4.1 "Troubleshooting Your System" for a description of this function.

### 3.3.3 RACE OPERATION

Race to race operation consists of the operator entering the vehicle numbers and dial-ins (if needed) for each lane. (If dial-ins are used, "Ready" (F9) should be pressed to indicate to the starter that the dial-ins are entered. Doing this will also display the dial-ins on the scoreboards if present and enabled. In addition, the win lights will be turned off.)

By using the function keys as shown next to the drivers' names, vehicle numbers and dial-in times on the main screen, the respective data can be entered. For example, pressing (ShiftF1) will allow you to type in the left lane's vehicle number. Once the number, name, or time have been typed in, it must be entered by pressing (ENTER).

Please refer to the HELP SCREEN at the front of Section 3.3.1 of this manual for the proper keystrokes.

When the race is complete, the operator presses (CTRL F8). This will:

1. Print the time slips.
2. Print the tower log.
3. Clear the screen and reset the timers.
4. Move vehicle numbers, drivers' names, and dial-ins from the "next" position to the "current" position.

### 3.3.4 INFRACTIONS

Driver infractions (such as out of bounds, disqualified, etc.) are entered using the (ALT) key in conjunction with one of the function keys. Please refer to the HELP SCREEN at the beginning of Section 3.3.1 of this manual for the proper keystrokes.

### 3.3.5 GUARD BEAM OPTION USE

This section only pertains to tracks using the Guard Beam option. For installation of the guard beam, see Section 2.6.6.

Once the guard beam is installed, the guard beam helps to enforce the NO DEEP STAGING rule. The stage line is used as the starting line and any car that stages too deeply, will set off the guard beam and will be disqualified from the race.

### **3.3.6 OPTIONAL JUDGE SYSTEM**

A judge system can be ordered that can give either true win or first to finish information at the finish line. If the judge system is connected to the Finish Line Junction Box the judge system will give first to finish information. If the judge system is connected to the C-33 the judge system will give true win information.

### **3.3.7 SCOREBOARD OUTPUT OPTION**

A Scoreboard Output board is an option that can be ordered for the C-33. This printed circuit board sends the C-33 signals to the optional displays.

### **3.3.8 RESULTS SYSTEM OPTION (CARS)**

The Chrondek Automated Results System (CARS) can be ordered as an option. This program can perform many important tasks for the announcer and tower personnel.

CARS can be used in conjunction with the C-33 timer to receive race information and relay that information to the announcer. National as well as track records are kept. Permanent event information can be kept. Ladder charts as well as pairings and qualifying orders can be generated and printed and much more.

## 4. TROUBLESHOOTING/MAINTENANCE

### 4.1 TROUBLESHOOTING YOUR SYSTEM

Two basic diagnostics programs come with the C-33. These programs help to locate minor problems with the system. The **Scoreboard Diagnostics** program will test all the lighted digits on a scoreboard to determine if they are all lighting. The **Win Light Diagnostics** program will determine if all the win lights are operating properly.

**Scoreboard Diagnostics** To activate the Scoreboard Diagnostics program press CTRL-S. The screen will show the numbers that are being sent to the respective fields on the scoreboard. If there are parts of a number that are not lighting, either a bulb has to be replaced or something is wrong with the scoreboard. See the scoreboard users manual for instructions on how to change a bulb.

**Win Light Diagnostics** The Win Light Diagnostics program can be activated by pressing CTRL-W. The screen will show the sequence that the Win Lights and judge system should follow when they light. If a Win Light or judge light does not light, either a bulb has to be replaced or something is wrong with the board. See the scoreboard users manual for instructions on how to change a bulb.

**Soft Reset** This function can be used to reset internal hardware to correct certain types of problems. This function should be used if any of the following situations arise.

1. Scoreboard output suddenly fails to function, but the C33 appears to be working.
2. The shack printer suddenly fails to function, but the C33 appears to be working.
3. The Tree/Starters box suddenly fail to function, but the C33 appears to be working.

**PROCEDURE:** Press [CTRL] [F1] then [CTRL] [R]

**NOTE:** There is no indicator to the operator that anything happened other than the problem may go away.

This function is benifical because the C33 does not need to be powered down, then up to fix the problem. This saves time during an event.

If there are any other problems with the C-33 system (that cannot be solved with the troubleshooting hints below) contact the Chrondek customer service department. Phone 1-800-854-6556 or in South Dakota, Alaska, or Hawaii call 1-605-697-4363.



## SYMPTOM/CONDITION

- Tree Does Not Light At All - Check Power to Tree  
- Check Fuse  
- Check bottom left corner of screen for SL CK  
- If SL CK IS THERE, check power to start line electronics box  
- Check SLEB to see if 3 LEDs are lit  
- Check tree boards
- Bulb In Tree Not Light - Change bulb  
- Check socket and wiring  
- Swap tree boards to see if problem moves  
- Check socket and wiring
- Bulb In Tree Stays Lit All The Time - Swap tree boards to see if problem moves
- Printer Not Working - Check to see if printer is selected on C-33  
- Check Power and Connector  
- Check to see if select light is lit on the front panel of printer
- If Log Printer - Exchange I/O Board
- If ET printer - Exchange Serial Board
- Dial-Ins Not Showing on Scoreboard-  
- In the scoreboard enable mode was a Y placed in for the dial in?  
- Is the F9 key being depressed?
- Reaction Time Not Showing Up on ET Printer  
- Check to see if it is switched ON on the front panel of C-33
- Nothing Appears on Monitor - Check monitor connection  
- Check power to C-33  
- Is fan running  
- Depress the reset switch
- Photocell Problems - Check to see if square lights on the monitor screen  
- Realign photocell  
- Change photocell  
- Exchange photocell boards if you have a spare parts kit

Weekend Phones - A technician is on call for the weekend. The phone will ring at Chrondek once and then be transferred to his home. If he is not there, he will be carrying a pager. Leave your name and number on the recorder. He will then be paged and he will return your call.

## 4.2 MAINTENANCE

Schematic diagrams of the SLEB, FLEB, and the Tree are given for maintenance considerations.

**TREE MAINTENANCE:** All the electronics needed to operate the Christmas Tree are located inside the tree on two printed circuit boards. These two boards are identical and may be interchanged to facilitate troubleshooting. The upper board services the left lane and the lower board services the right lane.

**Before opening the tree, make sure that the power cord has been removed from its outlet.** To replace the boards inside the tree, first remove the front cover by removing the eight screws securing it to the tree. Then, remove the single screw at the top of the board and remove it by pulling it straight out of its socket. Install the new board by reversing the procedure. **BE SURE TO REINSTALL THE SCREW holding the PC board in place before plugging the tree back in.**

A 15-amp fuse is located at the rear of the tree. If it blows repeatedly, **do not** change the rating. There is a problem with the PC boards or internal wiring.

## 4.3 REPLACEMENT PARTS

A complete list of replacement parts and their prices can be ordered for faulty or damaged equipment from Chrondek.

Phone: 1-800-854-6556 or 1-605-692-4363

To insure that the C-33 system rarely has to stop working because of damaged or faulty equipment, Chrondek recommends a **SPARE PARTS KIT** that can be ordered. Included in the SPARE PARTS KIT are:

<u>QTY</u>	<u>DESCRIPTION</u>
1	Input/Output board
1	Serial board
1	Photocell board
1	Time Slip printer board
1	Start Line/Finish Line board
1	Tree board
2	Photocell
2	Photocell back
4	Light source bulb
1	Dual light source
1	Starters' Console
2	8 amp Fuse
4	1/2 amp Fuse
2	1 amp Fuse
2	15 amp Fuse
6	2 1/2 amp Fuse
3	Lamp #382 midget-flanged base
3	Lamp 12 volt T5.5 slide base
1	Interface (optional-with displays)

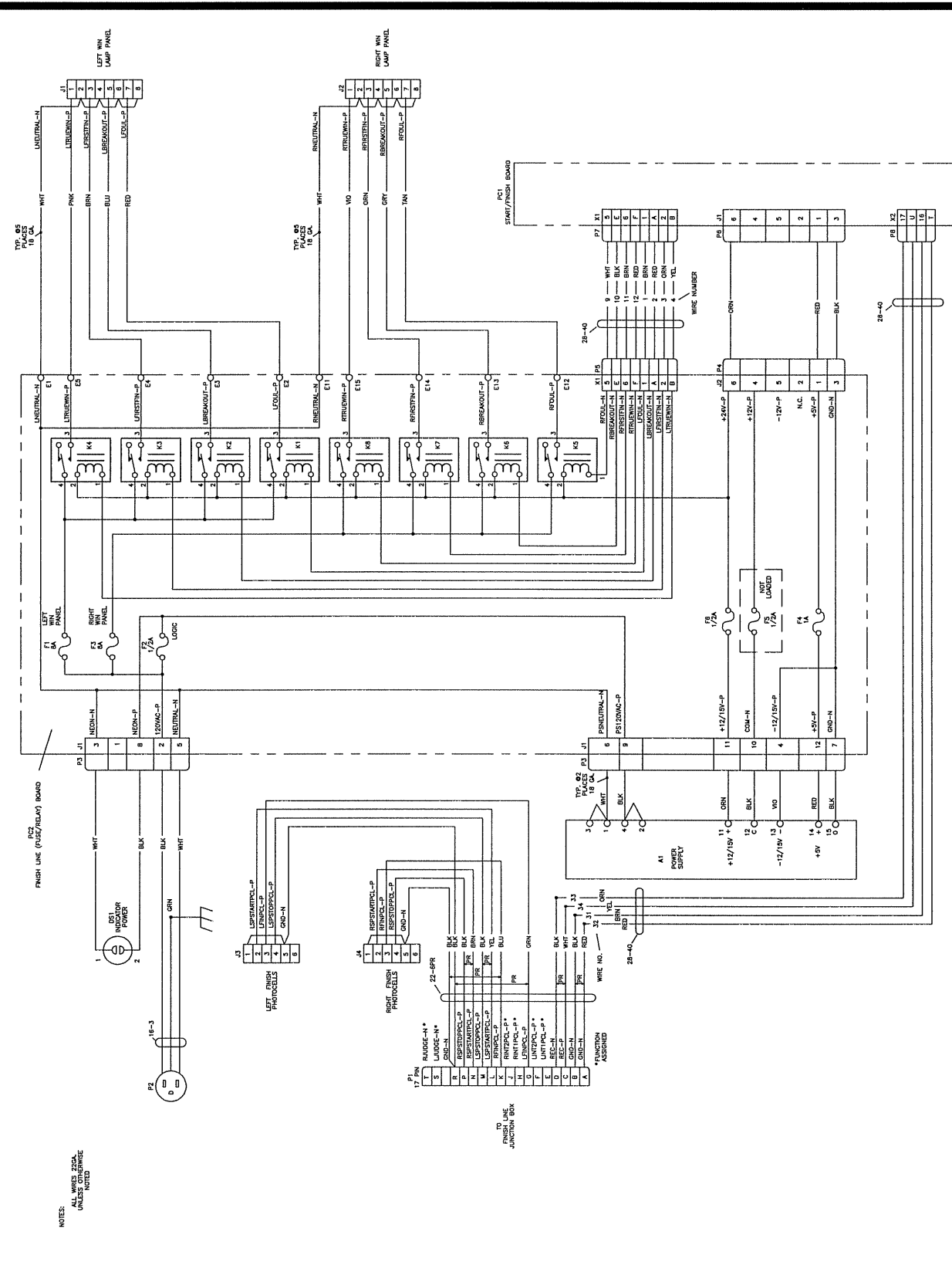

NOTES:  
ALL WIRE GAUGE  
UNLESS NOTED

FIGURE 24.0





#### 4.4 INTERNAL DIP-SWITCH SETTINGS ON THE I/O BOARD

The Input / Output Board is the first circuit board (from the front of the console, see Figure 27). There are two boxes of 8 dip-switches located on this board. Each switch has a unique function. The first box (on the right, when looking from the front of the console) holds the first eight switches (1-1 through 1-8). To remove the cover of the C-33, remove the four screws on each side of the console. The first box of dip-switches are defined as follows:

**WARNING: DO NOT ATTEMPT TO CHANGE ANY OF THE DIP SWITCH SETTINGS UNLESS YOU ARE QUALIFIED TO DO SO. CHRONDEK IS NOT RESPONSIBLE FOR ANY DAMAGE DONE TO THE CONSOLE WHILE CHANGING THE SWITCH SETTINGS. SEE YOUR NEAREST AUTHORIZED CHRONDEK DEALER TO HAVE THE SWITCHES CHANGED.**

##### FUNCTION OF SWITCHES 1-1 - 1-8

1-1 and 1-2 Switches 1-1 and 1-2 work together to tell the C-33 what length of speed trap will be used at the Finish Line. See the following chart for settings. 0 means the switch is OFF, 1 means ON.

<u>1-1</u>	<u>1-2</u>	<u>EFFECT</u>
0	0	Speed trap length is set to 2.64 feet.
1	0	Speed trap length is set to 13.2 feet.
0	1	Speed trap length is set to 132.0 feet.
1	1	Speed trap length is set to 66.0 feet.

The default setting for switches 1-1 and 1-2 is both ON for a speed trap length of 66.0 feet.

1-3 Switch 1-3 tells the C-33 whether to display the speeds in kilometers per hour (KPH) or miles per hour (MPH). Setting the switch to OFF will display all speeds in MPH. ON will display all speeds in KPH. The default setting for switch 1-3 is OFF or MPH.

1-4 Switch 1-4 sets the Auto Timer Reset. If the switch is OFF the starter cannot reset the timer using the starters' console box. If the switch is ON, the starter can reset the timer at any time using the starters' console box. The factory default setting for switch 1-4 is OFF.

C33 TIMER  
(TOP VIEW W/O COVER)

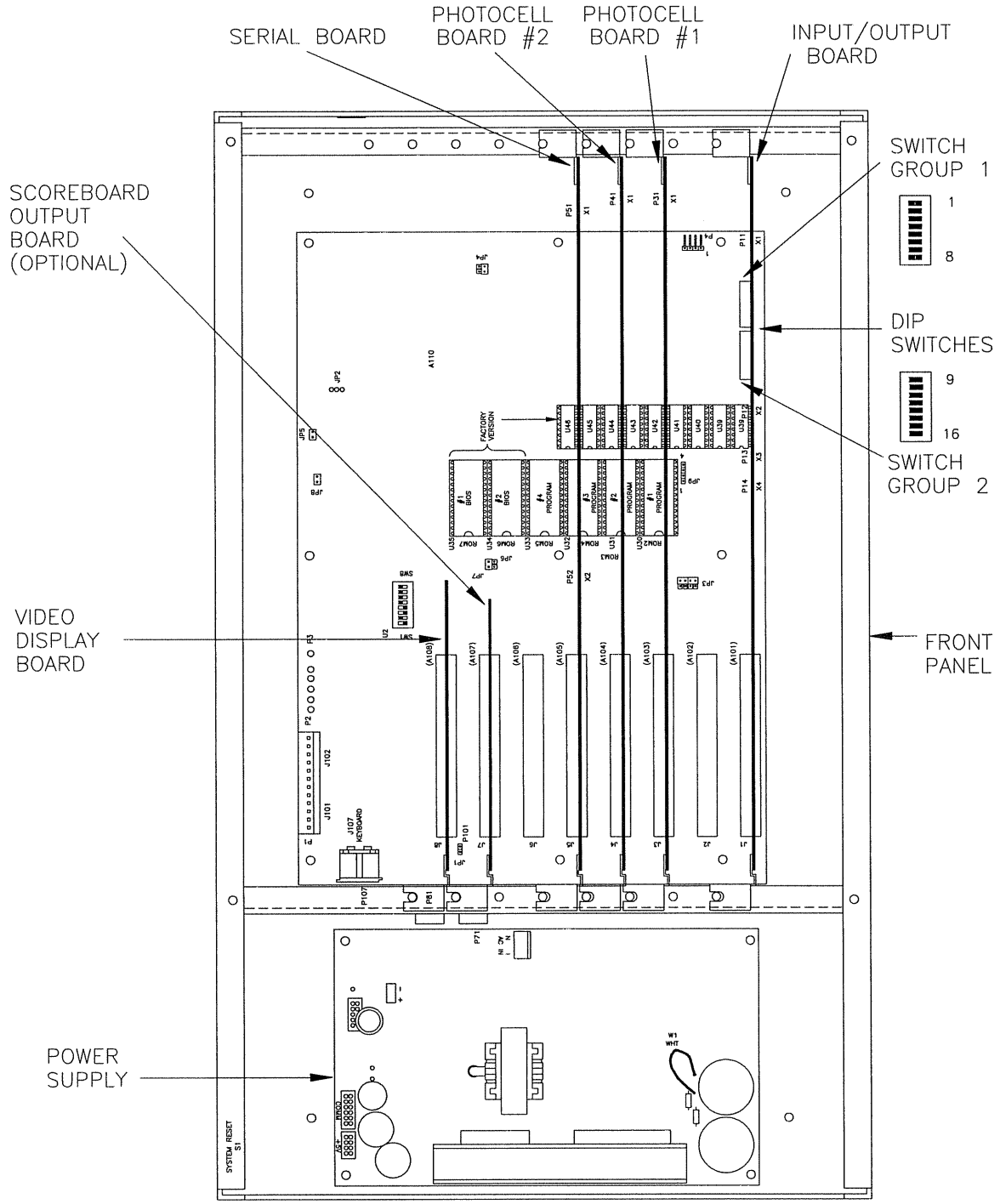

FIGURE 27.0

1-5 This switch enables or disables the Timer Reset Interlock. This switch will work only if switch 1-4 is OFF. If switch 1-5 is OFF the starter can activate the tree at any time. If the switch is ON the starter must wait until the timer has been reset by the C-33 operator before starting the tree countdown. The factory default setting for switch 1-5 is ON.

1-6 Switch 1-6 controls how the C-33 will work after a race is finished and a printout is made. If the switch is OFF, pressing CTRL-F8 will make a printout of that race and that is all. If the switch is ON and CTRL-F8 is pressed, the C-33 will make a printout, reset the timer, and move the next vehicle number to the current vehicle number position. This setting is a combination of the CTRL-F8 PRINT and CTRL-F7 NEXT VEHICLE NUMBER functions. The factory default setting for switch 1-6 is ON.

1-7 and 1-8 Switches 1-7 and 1-8 work together to control the operation of the C-33 with different types of scoreboards. The switch has the following settings:

<u>1-7</u>	<u>1-8</u>	<u>EFFECT</u>
0	0	C-33 is set for use with an ES-18.
1	0	C-33 is set for use with an MS-18.
0	1	C-33 is set for use with an CH-936DS or CH-936DS+S or CH-924DS or CH-936DS+SBL
1	1	C-33 is set for use with an CH-524DS or CH-536DS or CH-536DS+SBL

The default setting for switches 1-7 and 1-8 is both ON for use with CH-524DS, CH-536DS or CH-536DS+SBL Scoreboards.

The settings of switches 1-7 and 1-8 also effect the display of the SCOREBOARD ENABLE screen as well as the SCOREBOARD DIAGNOSTICS screen.

ES-18 and MS-18 settings The SCOREBOARD ENABLE (option <S> on the help menu) screen looks like the following for the switch settings of the single line ES-18 and dual-line MS-18:

```
RT  I1  I2  I3  I4  ET  DI  S1  SP
```

The SCOREBOARD DIAGNOSTICS (CTRL <S> option on the help menu) screen uses the following numbers to test the operation of the scoreboards for the ES-18 and MS-18 settings:

```
Left E.T.      --> 96.71
Left Speed     --> 896.73
Right E.T.     --> 97.35
Right Speed    --> 859.37
```



CH-936DS AND CH-924DS SERIES SETTINGS For the dual-line displays the SCOREBOARD ENABLE option has the addition of a "Bright" setting as shown:

RT I1 I2 I3 I4 ET DI S1 SP BRT

The BRIGHT function allows the lamps on the scoreboard to be either bright or dim. The default setting is bright (or a "Y" under the BRIGHT heading).

The SCOREBOARD DIAGNOSTICS test numbers are all eights for this scoreboard.

CH-524DS or CH-536DS SERIES SETTINGS For the single-line displays the SCOREBOARD ENABLE option has a second addition of an E.T./SPEED HOLD-TIME option as shown:

RT I1 I2 I3 I4 ET DI S1 SP BRT HOLD-TIME

This E.T./SPEED HOLD TIME option is needed for the single line display so the E.T. can be displayed for a specified period of time and then the speed can be displayed for a period of time. The times available are: 3, 8, and 15 seconds. The default setting is 15 seconds.

The SCOREBOARD DIAGNOSTICS test numbers are all eights for this scoreboard.

#### **FUNCTIONS OF SWITCHES 2-1 - 2-8**

2-1 Switch 2-1 tells the C-33 what kind of printer will be used as the time slip printer. If the switch is OFF, this tells the C-33 a C.ITOH printer is being used. If the switch is ON, this tells the C-33 an EPSON LX-810 printer is being used. Default setting is ON or an EPSON LX-810.

2-2 This switch tells the C-33 what kind of printer will be used as the tower log printer. The settings match those of switch 2-1. OFF is a C.ITOH and ON is a EPSON LX-810. Default setting is ON.

2-3 Switch 2-3 tells the C-33 where the win light is connected. If the switch is OFF, this tells the C-33 that the win light is connected to the Finish Line Electronics Box. If the switch is ON, this tells the C-33 that the win light is connected to the scoreboard interface. Default setting is ON.

2-4 Switch 2-4 tells the C-33 if it should enable the "Dual Deep Stage" rule. If this switch is ON and the SURESTART is enabled, the C33 will indicate a FOUL even if the other lane has fouled already. The default setting is OFF or "Dual Deep Stage" rule disabled.

2-5 and 2-6 Switch 2-5 and 2-6 work together to tell the C-33 what length of speed trap will be used at the 1/8 mile point. See the following chart for settings. 0 means the switch is OFF, 1 means ON.

<u>2-5</u>	<u>2-6</u>	<u>EFFECT</u>
0	0	Speed trap length is set to 2.64 feet.
1	0	Speed trap length is set to 13.2 feet.
0	1	Speed trap length is set to 132.0 feet.
1	1	Speed trap length is set to 66.0 feet.

The default setting for switches 2-5 and 2-6 is both ON or a speed trap of 66.0 feet.

2-7 Switch 2-7 tells the C-33 whether it is setup for two interim times and one speed trap or four interim times and two speed traps. Setting the switch to OFF will set up the C-33 for four interim times and two speed traps. Setting the switch to ON will set up the C-33 for two interim times and one speed trap. The default setting is OFF.

2-8 This switch is used in conjunction with the True Win push button on the front panel. If this switch is OFF, it has no effect on the operation. However, if it is ON, and the True Win push button on the front panel is OFF, the tree will count down at the same time even if the lanes have different dial-ins. But if the True Win pushbutton is ON, this switch has no effect on the operation. The default setting is OFF.

APPENDIX

A.1 LIST OF FIGURES

<u>Figure</u>	<u>Description</u>	<u>Page</u>
1.0	DRAG STRIP LAYOUT - GENERAL .....	4
2.0	DRAG STRIP LAYOUT - CABLING DIAGRAM .....	5
3.0	DRAG STRIP LAYOUT - FIELD CABLING .....	6
4.0	MOUNTING AND SPEED TRAP DISTANCE DIAGRAM ....	9
5.0	TRIPLE BRACKET MOUNT .....	11
6.0	TOWER JUNCTION BOX .....	14
7.0	START LINE JUNCTION BOX .....	15
8.0	START LINE ELECTRONICS BOX .....	17
9.0	START LINE DUAL LIGHT SOURCE .....	18
9.1	TREE PACKING AND ASSEMBLY DIAGRAM.....	20
10.0	SINGLE LIGHT SOURCE INTERMEDIATE .....	22
11.0	TRANSFORMER - INTERMEDIATE .....	24
12.0	FINISH LINE JUNCTION BOX .....	26
13.0	FINISH LINE ELECTRONICS BOX .....	27
14.0	FINISH LINE TRANSFORMER .....	31
15.0	PHOTOCELL SIGHTING DIAGRAM .....	38
16.0	C-33 FRONT AND BACK PANELS.....	40
17.0	C-33 MAIN SCREEN .....	41
18.0	STARTERS' CONSOLE .....	45
19.0	ALTITUDE ADJUSTMENT EXAMPLE SCREEN .....	47
20.0	ALTITUDE ADJUSTMENT EXAMPLE TIME SLIP .....	49
21.0	ALTITUDE ADJUSTMENT EXAMPLE LOG PRINTOUT ....	49
22.0	ALT. ADJ. IDENTICAL RACE WITHOUT ADJUSTMENT .	50
23.0	C-33 HELP SCREEN .....	53
24.0	FINISH LINE ELECTRONICS BOX SCHEMATIC .....	64
25.0	START LINE ELECTRONICS BOX SCHEMATIC .....	65
26.0	THREE AMBER TREE SCHEMATIC .....	66
27.0	DIP SWITCH LOCATION DIAGRAM .....	68

## APPENDIX

### A.2 LIST OF DATA TABLES

<u>Table No.</u>	<u>Description</u>	<u>Page</u>
1.0	Power Requirements Table	7
2.0	TJB to SLJB wiring list	16
3.0	60' intermediate photocell wiring list	21
4.0	1/8th mile photocell wiring list	21
5.0	TJB and FLJB wiring list	25
6.0	Left win light plug soldering connections	28
7.0	Right win light plug soldering connections	28
8.0	Right Speed trap and Finish PCL to FLEB plug conn.	29
9.0	Left Speed trap and Finish PCL to FLEB plug conn.	29
10.0	Time Slip Printer Wiring	30
11.0	Judge system to C-33 wiring list	30
12.0	Judge system to FLJB wiring list	30
13.0	Scbd interface to right scbd wiring list	32
14.0	Scbd interface to left scbd wiring list	32

**APPENDIX**

**A.3 INFRARED PHOTOCELLS**

<u>Figure</u>	<u>Description</u>	<u>Page</u>
A3.1	Drag Strip - Infrared Cabling Diagram.....	78
A3.2	Infrared Photocell; Emitter W/Stand.....	79
A3.3	Infrared Photocell; Receiver W/Stand.....	80
A3.4	Infrared Photocell; Emitter/Receiver W/Stand 10"....	81
A3.5	Infrared Photocell; Emitter/Receiver W/Stand 6"....	82
A3.6	Infrared Photocell; Reflector W/Stand.....	83
A3.7	Assy; Dual Banana Plug.....	84

**INTRODUCTION TO INFRARED PHOTOCELLS**

Figure A3.1 shows a cabling diagram of a typical drag strip using Infrared Photocells. It is intended to be a guide in locating and cabling to the photocells.

The terminology Emitter and Receiver are used with the opposed beam photocells. (Light is emitted from one and received into another unit.) The term Emitter/Receiver is used with the retroreflective type photocell. (A photocell which light from the Emitter is reflected back to the Receiver. Both Emitter and Receiver are inside the same unit.)

Details of the different Infrared Photocells and their mountings are given in figures A3.2 - 3.6. A detail of the Dual Banana Plug assembly is shown in figure A3.7. This would be used to terminate field cables for plugging in the Infrared Photocells.

The following sections have been divided into the two types of Photocells used.

**INSTALLATION AND ALIGNMENT OPPOSED BEAM INFRARED PHOTOCELLS**

Opposed ("beam break") sensing which is used at the start line results in the most reliable sensing system. Opposed sensing is the most efficient sensing mode, and offers the highest level of optical energy to overcome lens contamination, sensor misalignment.

**NOTES ABOUT THE "EFFECTIVE BEAM"**

The size of the lens of the emitter and receiver of an opposed sensor pair determines the size of the pair's effective beam. The effective beam may be pictured as a rod which connects the profile of the emitter lens to the profile of the receiver lens. The effective beam is the "working" part of the photoelectric beam: it is the portion of the beam which must be completely interrupted in order for an object to be reliably sensed. It should not be confused with the actual radiation pattern of the emitter, or with the field of view of the receiver. The effective beam size of photocell pair is one inch in diameter.

#### NOTES ABOUT LED INDICATOR:

An exclusive built-in feature that permits optimum alignment and continuous monitoring of the photoelectric system. The red receiver LED indicator is "on" when the receiver "sees" the modulated light from the emitter LED and "off" when the beam is broken. In addition, a low frequency pulse rate is superimposed on the LED indicator. When alignment is marginal, the pulse rate will be about once per second (indicating an excess gain of 1). As alignment is improved, the pulse rate increases, indicating increased excess gain. Optimum sensor alignment is indicated by the fastest pulse rate.

This feature also signals when maintenance is needed. Any pulse rate less than two or three beats per second indicates marginal performance, even though the units are still functioning properly. Whenever the pulse rate is slow, the lenses should be cleaned and/or the alignment checked.

If the alignment indicator on the receiver appears to be "on" steadily with no pulsing evident, it is actually pulsing at a rate that is too fast to be seen. A "steadily on" LED indicates an excess gain of at least 20X.

At ranges within a few feet, the power of opposed scanner blocks makes alignment simple. However, even at short range, it may be important to optimize alignment, especially if high excess gain is needed to "burn through" dirt, dust, steam, etc.

The best way to align a receiver to its emitter at short range is to drastically reduce the strength of the light signal. This is easily accomplished by placing a diffuser, such as a sheet of paper or light colored masking tape, in front of the emitter and/or receiver lens.

#### For alignment:

- 1) Begin with the emitter mounted securely in place. At ranges up to a few feet, the receiver may simply be mounted using line-of-sight alignment. At distances beyond a few feet, loosely mount the receiver opposite the emitter, leaving a means for movement.
- 2) If sensing is to be at an exact location, tie a string around the emitter at the center of its lens and extend it to the center of the receiver lens to make certain that the center of the beam will intersect the sensing point.
- 3) Apply power to the emitter and receiver power blocks. The Alignment Indicating Device LED on the receiver should now be "on" (steadily or pulsing).

- 4) If the indicator LED is "on" steadily, place a diffusing material (paper, tape, etc) in front of the lens of the emitter and/or receiver. Use enough thickness to cause the receiver LED to pulse at an easily countable rate (one to five beats per second). Now move the receiver up/down/left/right (include rotation) to try to increase the pulse rate. Secure the receiver in the position where the pulse rate is fastest, or in the center of the area where the alignment LED is "on" steadily.
- 5) Increase the receiver sensitivity to maximum. The SENSITIVITY control, located under the white nylon access screw next to the indicator LED, is a 15-turn potentiometer clutched at both ends of rotation. To increase receiver sensitivity, turn the control clockwise with a small flat-blade screwdriver.
- 6) Place the object to be detected at the sensing position. If the receiver alignment LED goes "off", alignment is complete.

NOTE: If the receiver alignment LED does not go "off" when the object is in place at the sensing position, the reason may be one or both of the following:

- a) FLOODING: A portion of the effective beam may be passing around one or both sides of the object. Move the object back and forth to locate the center of the beam.
- b) BURN-THROUGH: If the object is non-metallic or has thin walls, there may be too much light energy for the object to completely block. With the object in place in the sensing position, decrease the sensitivity adjustment (CCW rotation) until the receiver indicator LED goes "off", plus two more full turns. Remove the object and confirm that the LED indicator comes "on" and is pulsing more than two beats per second.

## INSTALLATION AND ALIGNMENT RETROREFLECTIVE PHOTOCELLS

Retroreflective mode photoelectric sensing is ideal for off start line applications which opposed mode sensing would be the first choice, but where sensing is from only one side. "Retro" is the most popular sensing mode for applications where objects are large and the environment is relatively clean.

Retroreflective sensors work with special target materials that reflect the emitted light beam back to the sensor. The efficiency of these targets (and, therefore, the sensing range) depends upon the size and the reflectivity of the target. Size is important because, at ranges beyond a few feet, the retro target may not intercept the complete beam. At an extended range, a 3" diameter target will intercept nine times as much light as a 1" diameter target (the area ration is the square of the diameter ratio). The 1" target will, therefore, require nine times the excess gain required for the 3" target.

Reflectivity is a function of target construction. Most plastic targets are made up of small, highly efficient corner-cube reflectors.

Successful retroreflective mode sensing depends upon adequate optical contrast between the dark (beam broken) state and the light (beam unbroken) state. Retroreflective sensing, therefore, works best with objects of low reflectivity. Highly reflective objects such as glass, polished metal, mirrors, etc. may not be sensed because they can reflect as much or nearly as much light back to the sensor as does the retroreflective target. This effect is known as "proxing". At the other extreme, transparent objects are difficult to sensor retroreflectively because they may not sufficiently interrupt the sensor's light beam.

Proper operation of retroreflective mode sensors requires that they be mounted securely and aligned properly. Excessive movement or vibration can result in intermittent or false operation caused by loss of alignment to the retroreflective target.

Use the LED on the photocell in the following alignment procedure:

- 1) Begin with the sensor at the desired distance from the retroreflective target and at the approximate position where it will be mounted. Retroreflective targets are rather forgiving to beam angle in that they do not begin to lose effectiveness until they are more than 15 degrees off of perpendicular to the beam axis. An object at the "sensing position" should pass through the "core" of the sensor's light beam.
- 2) Apply power and perform one of the following steps (see notes below):

If in either case the LED appears to be "on" steadily, it is actually pulsing at a rate too fast to be seen. Slow the pulsing to a "countable" rate by reducing the sensitivity (counterclockwise rotation of the adjustment). Being able to detect a change in the pulse rate when the position of the sensor or reflector is changes will allow accurate alignment.



- a) If the target position is fixed, tilt the sensor up/down and rotate right/left to obtain the fastest indicator LED pulse rate (no object at the sensing position). Secure the sensor in position.
- b) If the sensor position is fixed, move the target up/down and right/left to obtain the fastest indicator LED pulse rate (no object at the sensing position). Secure the target in position.

At sensing distances up to 3 feet finding "the target with the sensor beam may be difficult. Take a second target and walk backwards away from the sensor, always keeping the target aligned to the beam (up/down/right/left target movement; observe LED indicator). When you reach the target's mounting surface, the correct target position or necessary sensor orientation changes will be obvious.

- 3) Turn the sensor's SENSITIVITY control to the fully clockwise position. (This is a 15-turn control, clutched at both ends of travel).
- 4) Place the object to be detected at the sensing position. If the alignment indicator LED goes "off", check operation by alternately removing and replacing the object. The LED should "follow" the action by coming "on" when the object is not present and going "off" when the object is present. If this occurs, alignment is complete. NOTE: a steady "on" condition of the LED with the object absent is the best situation, but this may not always be possible to achieve.
- 5) If the alignment indicator says "on" when the object is present at the sensing position, the photocell is reacting to light reflected directly from the object ("proxing" is taking place). Reduce the sensitivity (counterclockwise rotation of the adjustment) until the alignment indicator LED goes "off", plus two more full turns. Remove the object from the sensing position and check that the alignment indicator LED goes "on" steadily or is pulsing at more than two beats per second. Then repeat step #4 (above).

ITEM	DESCRIPTION
7	TOWER JUNCTION BOX
8	CABLE; TIMER TO TOWER J-BOX, 6 FT.
10	TOWER SCOREBOARD JUNCTION BOX
11	CABLE; TOWER SCOREBOARD J-BOX TO TIMER TO INTERFACE
12	ET PRINTER
13	CABLE; PRINTER INTERFACE TO ET PRINTER TERMINAL BLOCK, 6 FT.
14	CABLE; TOWER J-BOX TO ET PRINTER TERMINAL BLOCK, 1500 FT.
15	START LINE ELECTRONICS BOX, W/ 6 FT. CABLE
16	START LINE JUNCTION BOX
17	CABLE; START LINE ELECTRONICS BOX TO TOWER J-BOX, 200 FT.
18	STARTER'S CONSOLE BOX, W/ 20 FT. CABLE
19	3 AMBER STARTING TREE
20	CABLE; TREE TO START LINE ELECTRONICS BOX, 50 FT.
24	CABLE; START INFRARED TO START LINE ELECTRONICS BOX, 20 FT.

ITEM	DESCRIPTION
46	ET/MPH DISPLAY
47	CABLE; DISPLAY TO SCOREBOARD J-BOX, 2000 FT.
48	CABLE; DISPLAY TO DISPLAY, 200 FT.
51	PRINTER INTERFACE BOX
52	CABLE; INTERMEDIATE LINES, 6 FT.
53	CABLE; PHOTOCELL TO FIELD CABLE 22GA.
60	PHOTOCELL; INFRARED EMITTER/RECEIVER
61	BASE; INFRARED
62	PHOTOCELL; INFRARED REFLECTOR
63	BASE; DUAL PHOTOCELL
64	PHOTOCELL; INFRARED EMITTER
65	PHOTOCELL; INFRARED RECEIVER
66	BASE; INFRARED, START LINE
67	CABLE; PHOTOCELL, FIELD CABLE

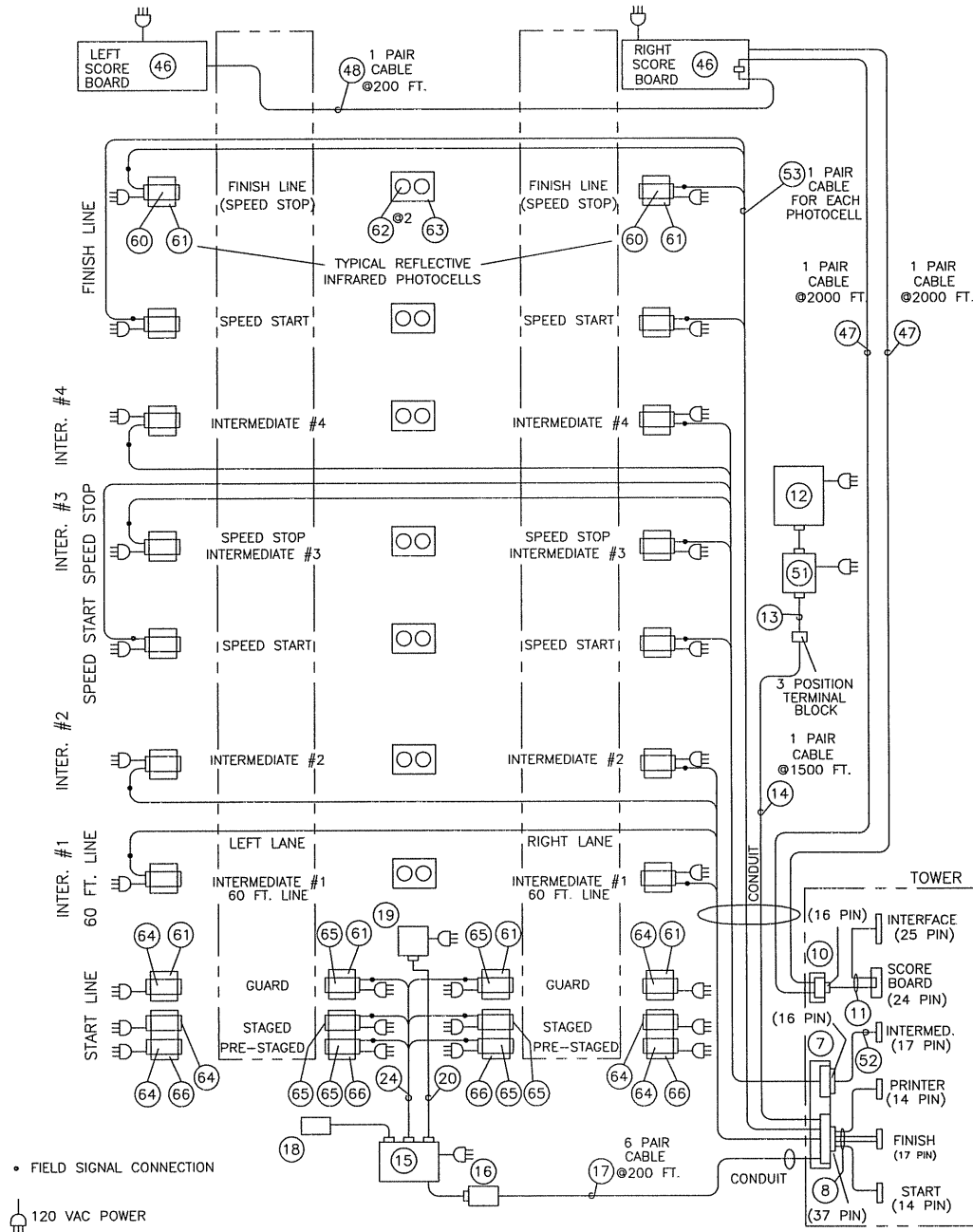
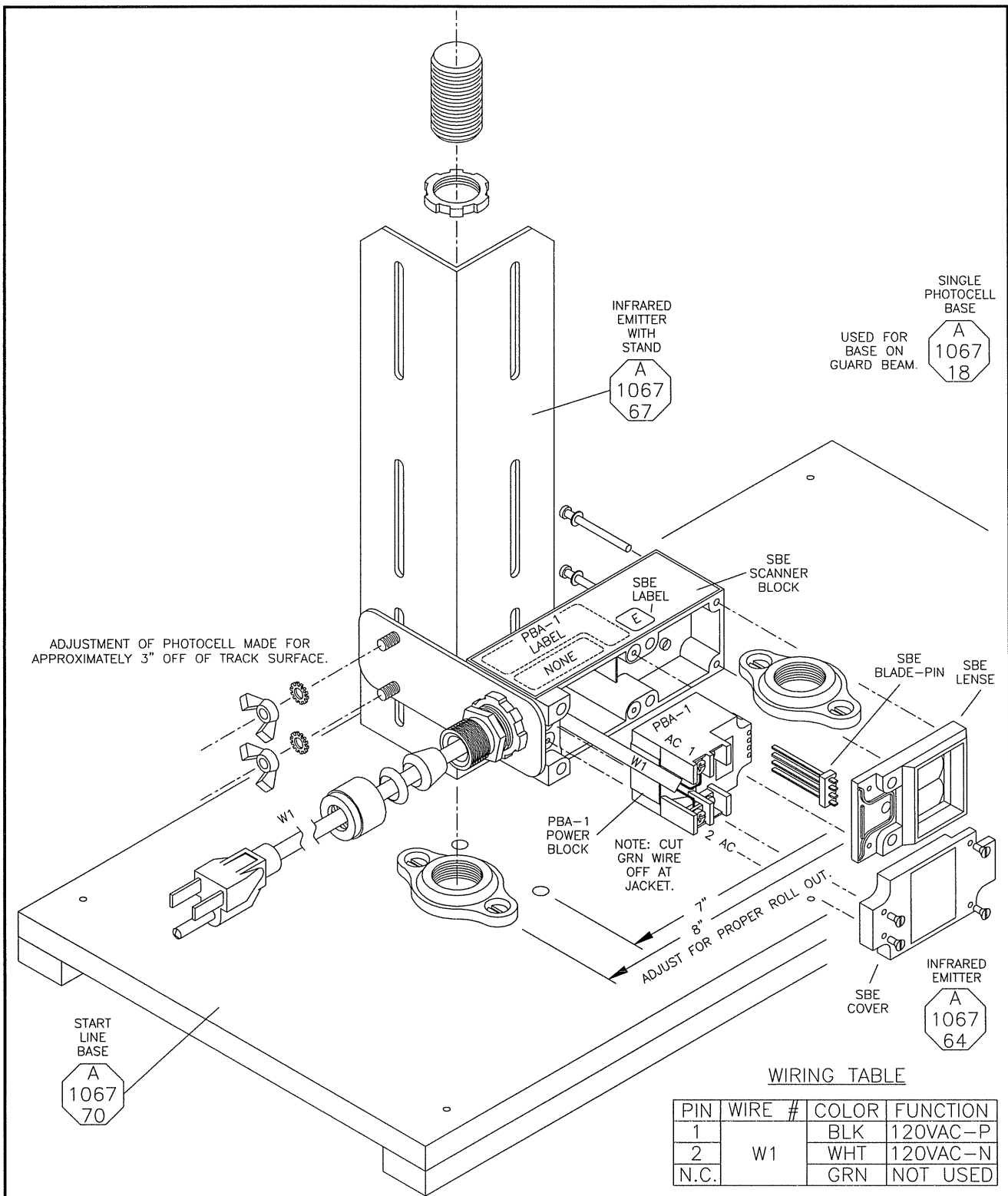

FIGURE A3.1

DAKTRONICS, INC. BROOKINGS, SD 57006			
PROJ: CHRONDEK, INC.			
TITLE: DRAG STRIP - INFRARED CABLING DIAGRAM			
DES. BY:	DRAWN BY: J.M.LAMBERTZ		DATE: 13 MAY 91
REVISION	APPR. BY:	SCALE: NONE	
		1067-R11A-47274	

REV.	DATE	DESCRIPTION	BY	APPR.



SINGLE PHOTOCELL BASE  
 USED FOR BASE ON GUARD BEAM.  
 A  
 1067  
 18

INFRARED EMITTER WITH STAND  
 A  
 1067  
 67

ADJUSTMENT OF PHOTOCELL MADE FOR APPROXIMATELY 3" OFF OF TRACK SURFACE.

7"  
 8"  
 ADJUST FOR PROPER ROLL OUT.

START LINE BASE  
 A  
 1067  
 70

INFRARED EMITTER  
 A  
 1067  
 64

WIRING TABLE

PIN	WIRE #	COLOR	FUNCTION
1	W1	BLK	120VAC-P
2		WHT	120VAC-N
N.C.		GRN	NOT USED

FIGURE A3.2

DAKTRONICS, INC. BROOKINGS, SD 57006

PROJ: CHRONDEK, INC.

TITLE: INFRARED PHOTOCELL; EMITTER W/ STAND

DES. BY: DRAWN BY: M. RICHARDSON DATE: 14 MAY 91

REVISION APPR. BY: SCALE: 3=8

1067-R11A-47262

REV.	DATE	DESCRIPTION	BY	APPR

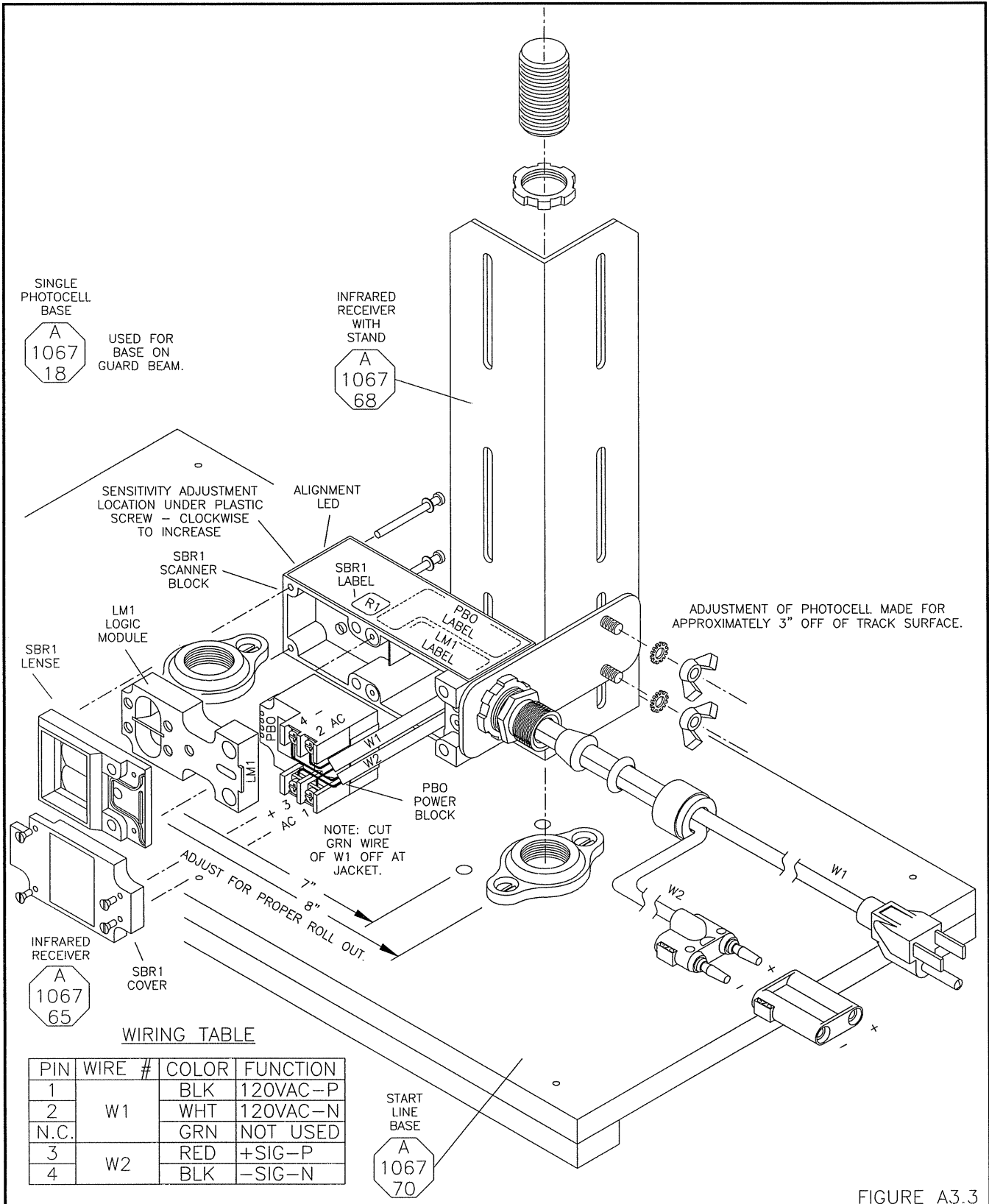

SINGLE PHOTOCCELL BASE  
A  
1067  
18

USED FOR BASE ON GUARD BEAM.

INFRARED RECEIVER WITH STAND  
A  
1067  
68

SENSITIVITY ADJUSTMENT LOCATION UNDER PLASTIC SCREW - CLOCKWISE TO INCREASE

ALIGNMENT LED

SBR1 SCANNER BLOCK

SBR1 LABEL

PBO LABEL

LM1 LABEL

ADJUSTMENT OF PHOTOCCELL MADE FOR APPROXIMATELY 3" OFF OF TRACK SURFACE.

LM1 LOGIC MODULE

SBR1 LENSE

AC

AC

AC

AC

AC

AC

AC

AC

AC

AC

AC

AC

AC

AC

AC

AC

AC

AC

AC

AC

AC

AC

AC

AC

AC

NOTE: CUT GRN WIRE OF W1 OFF AT JACKET.

ADJUST FOR PROPER ROLL OUT.  
7"  
8"

INFRARED RECEIVER  
A  
1067  
65

SBR1 COVER

WIRING TABLE

PIN	WIRE #	COLOR	FUNCTION
1		BLK	120VAC-P
2	W1	WHT	120VAC-N
N.C.		GRN	NOT USED
3	W2	RED	+SIG-P
4		BLK	-SIG-N

START LINE BASE  
A  
1067  
70

FIGURE A3.3

DAKTRONICS, INC. BROOKINGS, SD 57006	
PROJ: CHRONDEK, INC.	
TITLE: INFRARED PHOTOCCELL; RECEIVER W/ STAND	
DES. BY:	DRAWN BY: M. RICHARDSON DATE: 14 MAY 91
REVISION	APPR. BY:
	SCALE: 3=8
1067-R11A-47263	

REV.	DATE	DESCRIPTION	BY	APPR.

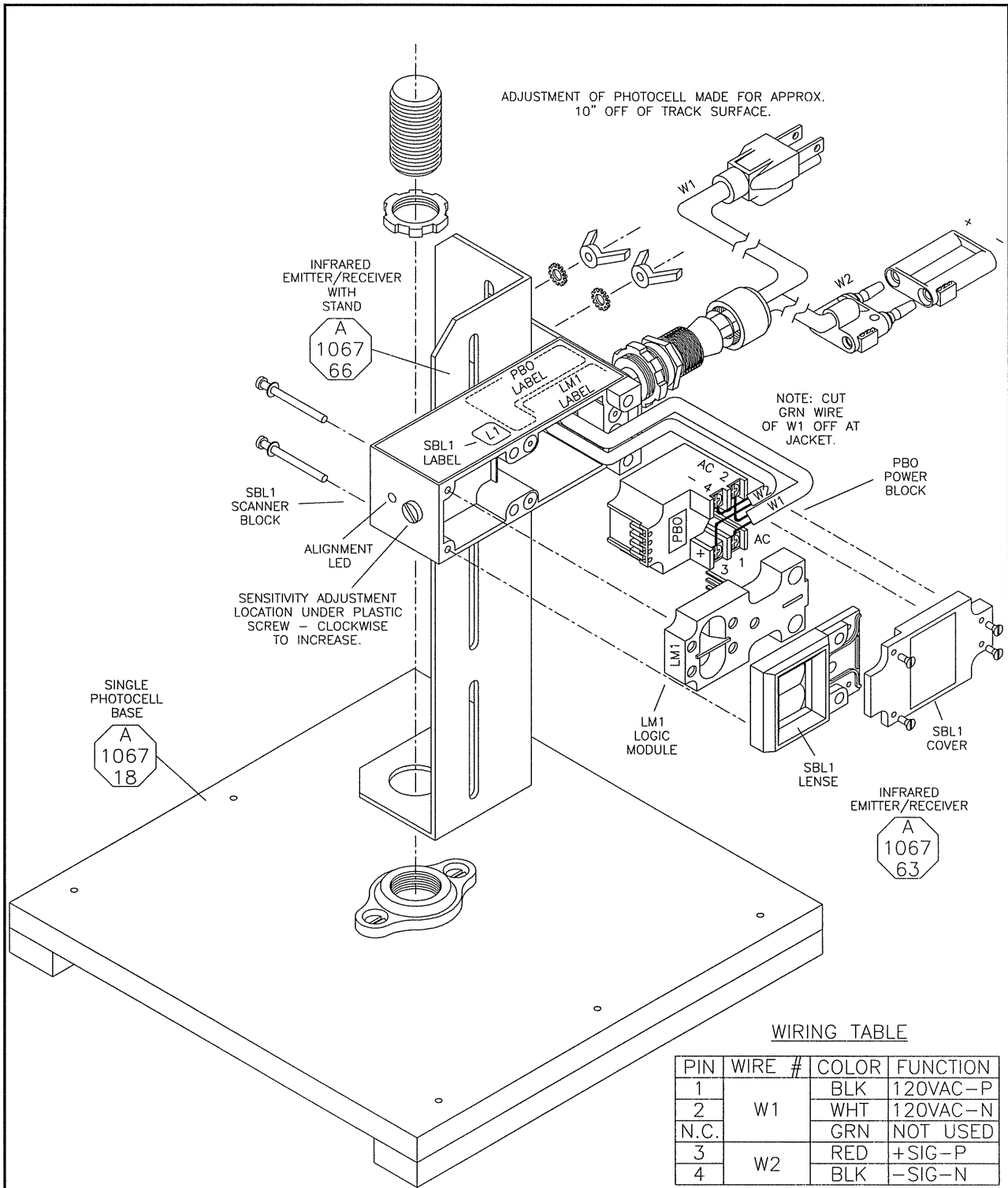

WIRING TABLE

PIN	WIRE #	COLOR	FUNCTION
1	W1	BLK	120VAC-P
2		WHT	120VAC-N
N.C.		GRN	NOT USED
3	W2	RED	+SIG-P
4		BLK	-SIG-N

FIGURE A3.4

DAKTRONICS, INC. BROOKINGS, SD 57006	
PROJ: CHRONDEK, INC.	
TITLE: INFRARED PHOTOCELL; EMITTER/RECEIVER W/ STAND 10"	
DES. BY:	DRAWN BY: M. RICHARDSON DATE: 14 MAY 91
REVISION	APPR. BY:
	SCALE: 3=8
1067-R11A-47264	

REV.	DATE	DESCRIPTION	BY	APPR.

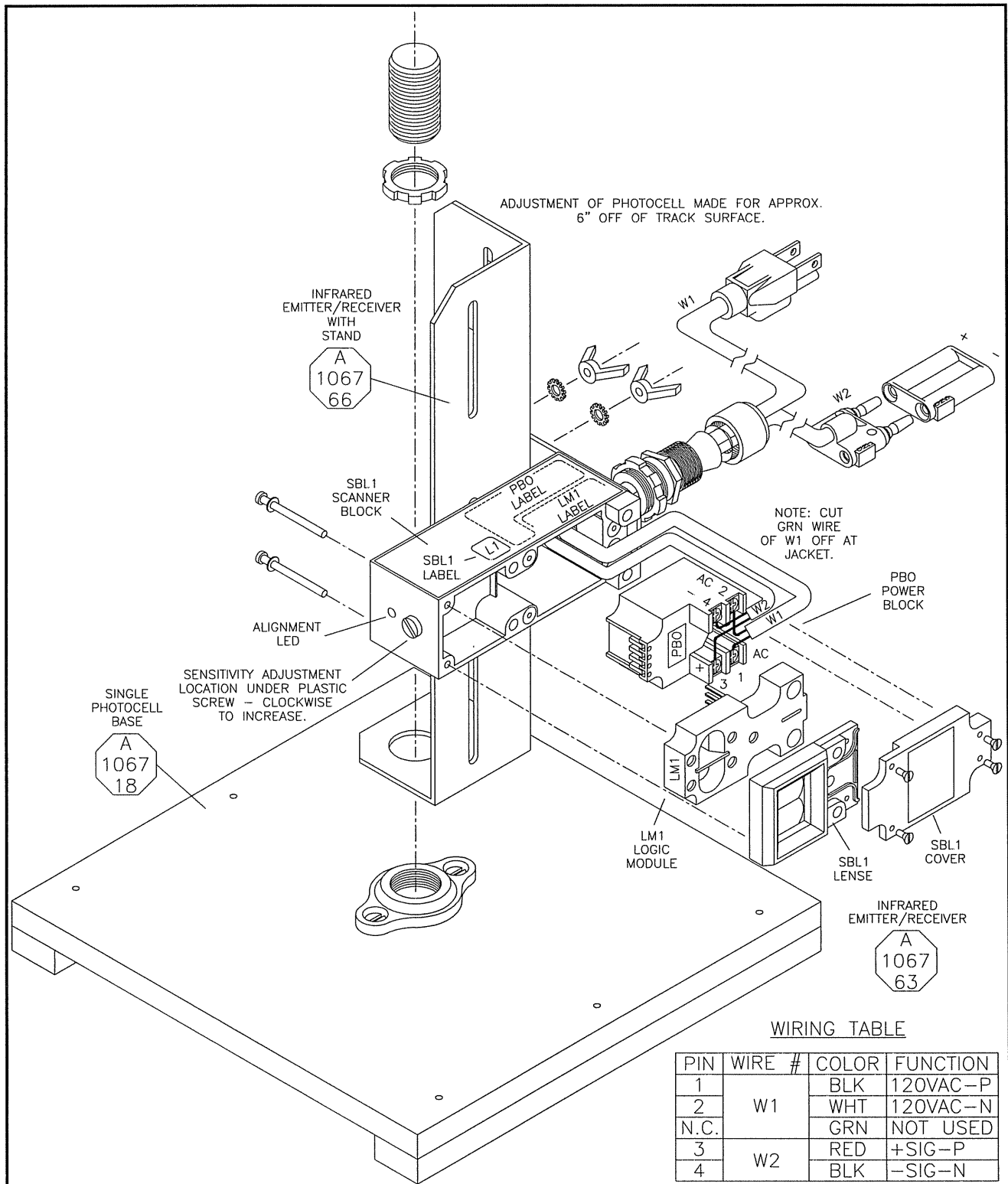

FIGURE A3.5

DAKTRONICS, INC. BROOKINGS, SD 57006	
PROJ: CHRONDEK, INC.	
TITLE: INFRARED PHOTOCELL; EMITTER/RECEIVER W/ STAND 6"	
DES. BY:	DRAWN BY: M. RICHARDSON DATE: 14 MAY 91
REVISION	APPR. BY:
	SCALE: 3=8
1067-R11A-47265	

REV.	DATE	DESCRIPTION	BY	APPR.

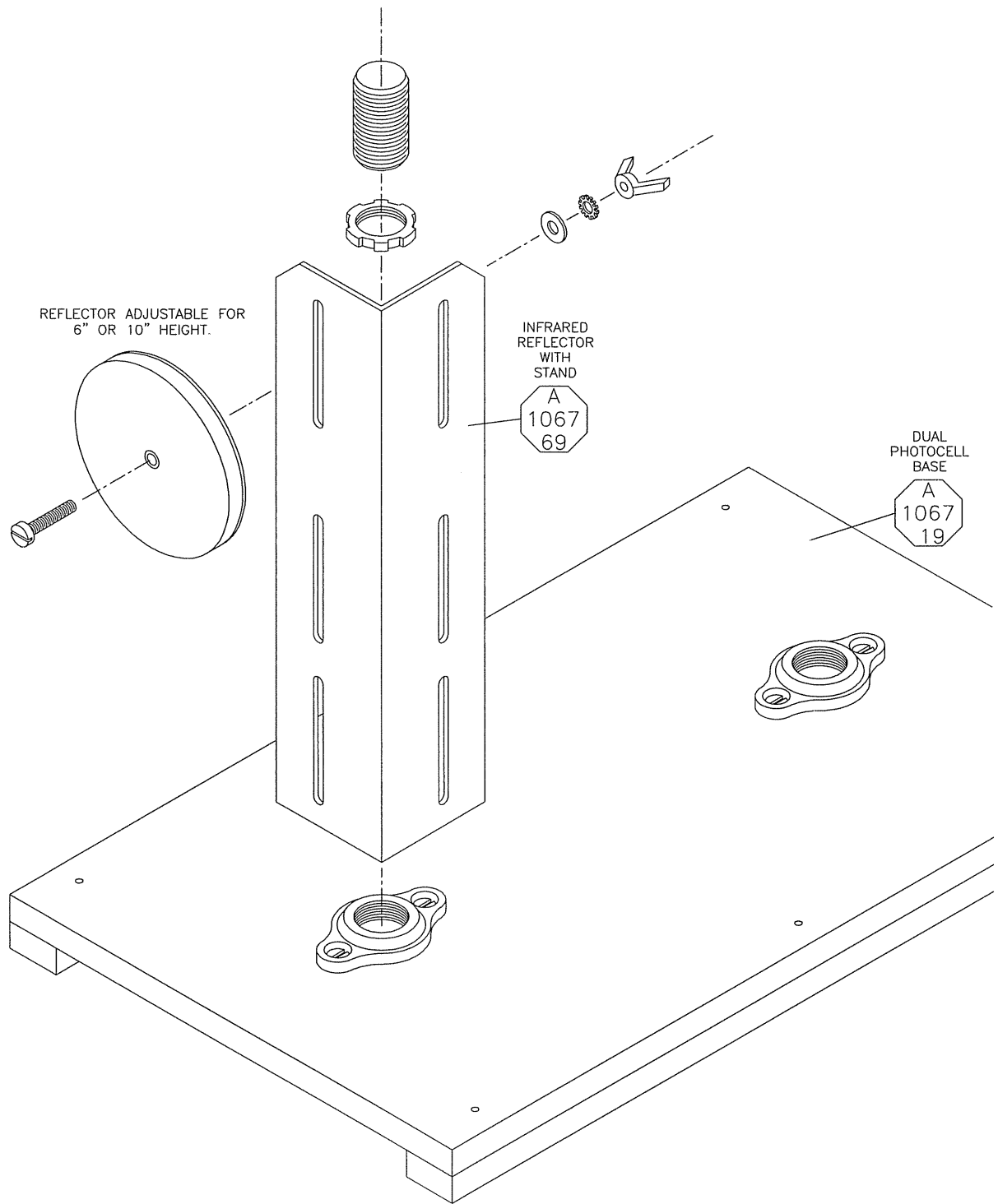
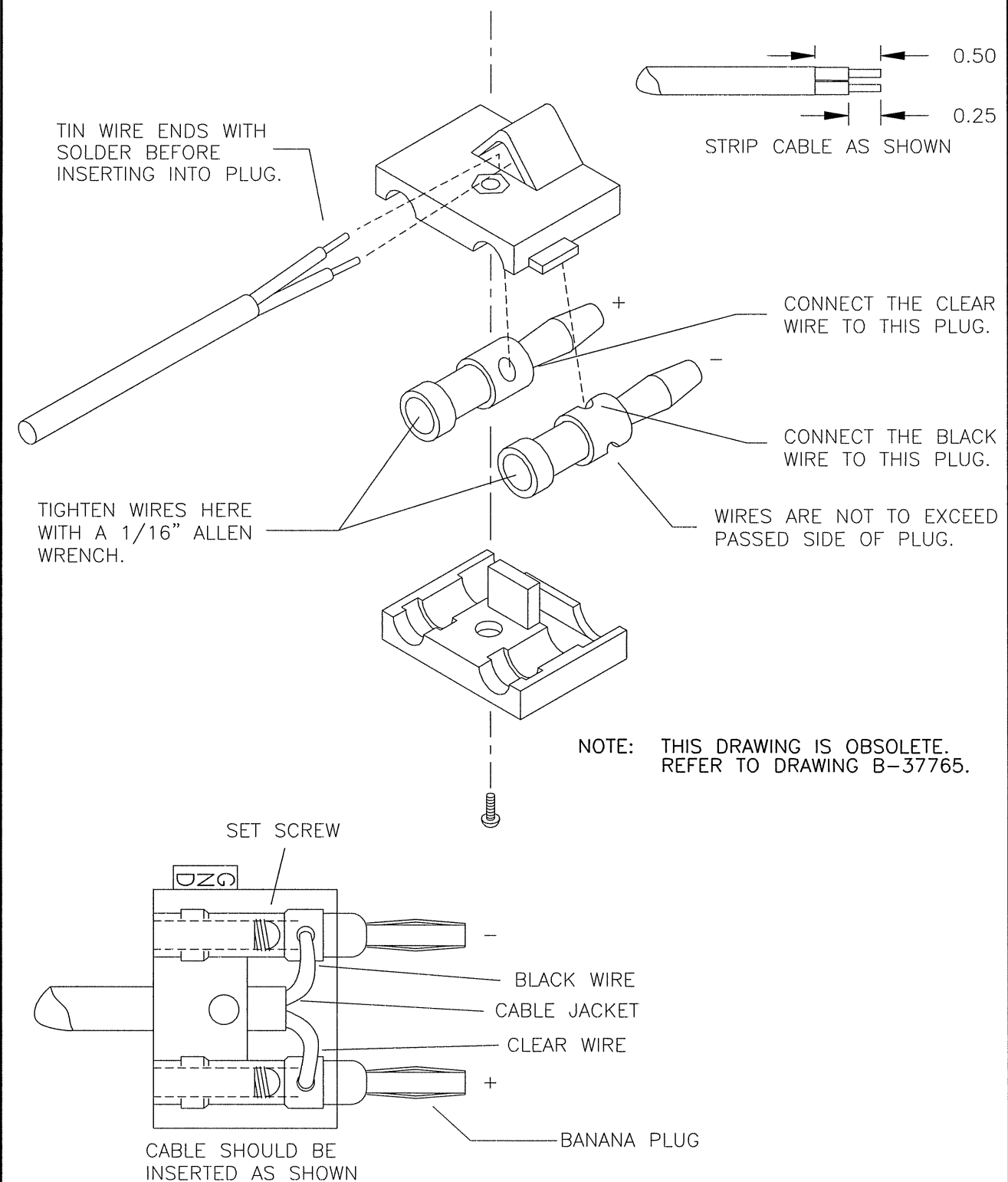

FIGURE A3.6

DAKTRONICS, INC. BROOKINGS, SD 57006	
PROJ: CHRONDEK, INC.	
TITLE: INFRARED PHOTOCELL; REFLECTOR W/ STAND	
DES. BY:	DRAWN BY: M. RICHARDSON DATE: 14 MAY 91
REVISION	APPR. BY:
	SCALE: 3=8
1067-R11A-47266	

REV.	DATE	DESCRIPTION	BY	APPR.



NOTE: THIS DRAWING IS OBSOLETE. REFER TO DRAWING B-37765.

FIGURE A3.7

DAKTRONICS, INC. BROOKINGS, SD 57006				
PROJ: CHRONDEK, INC.				
TITLE: ASSY; DUAL BANANA PLUG				
REV. 1		DATE 26 OCT 99		DESCRIPTION DRAWING OBSOLETE. USE DRAWING B-37765.
				BY HBB
				APPR.
				DES. BY: DRAWN BY: M. RICHARDSON DATE: 14 MAY 91
				REVISION APPR. BY: SCALE: NONE
				1067-R11A-47267