



Auto Racing Display Model CH-1036H

Installation & Maintenance Manual

ED 6616

**ED 6616
Project#1081
Rev. 2 - 06 August, 1998**

Copyright © 1992 Daktronics, Inc.

All rights reserved. While every precaution has been taken in the preparation of this manual, the publisher assumes no responsibility for errors or omissions. No part of this book covered by the copyrights hereon may be reproduced or copied in any form or by any means - graphic, electronic, or mechanical, including photocopying, taping, or information storage and retrieval systems - without written permission of the publisher.



**DA
KTRONICS, INC.**
Setting New Standards Worldwide

P.O. Box 5128 331 32nd Ave. Brookings, SD 57006
Phone (605)697-4400 or (800) 843-9879 Fax 697-4444



Table of Contents

1.	Introduction	1-1
1.1	How To Use This Manual	1-1
1.2	Display Overview.....	1-1
2.	Installation	2-1
2.1	General System.....	2-1
2.2	Beam and Footing Selection.....	2-1
2.3	Display Mounting.....	2-2
2.4	Electrical Installation.....	2-2
	2.4.1 Control Signal Cable	2-2
	2.4.2 Power Wiring	2-3
3.	Maintenance & Troubleshooting.....	3-1
3.1	Lamp Replacement.....	3-1
3.2	Lamp Driver	3-1
3.3	Digit Segmentation.....	3-1
3.4	Schematic	3-2
3.5	Troubleshooting	3-2
3.6	Replacement Parts	3-3
3.7	Unit Exchange/Replacement Procedure	3-3

Section 1: Introduction

1.1 How To Use This Manual

This manual explains the installation and maintenance of the CH-1036H auto racing display system. Setup of other control equipment or operation of the CHTS-300 timing console are not covered in this manual. For questions regarding the safety, installation, operation or service of this system, please refer to the telephone numbers listed on the cover page of this manual.

Important Safeguards:

1. Read and understand these instructions before installing.
2. Do not drop the control console or allow it to get wet.
3. Be sure the scoreboard is properly grounded with a ground rod at the display location.
4. *Disconnect power to the display when it is not in use.*
5. *Disconnect power when servicing the display.*
6. Do not modify the display structure or attach any panels or coverings to the display without the written consent of Daktronics, Inc.

The box below illustrates Daktronics drawing numbering system. The drawing number “7087-P08A-69945” is how Daktronics identifies individual drawings. This number is located in the lower-right corner of the drawing. This manual refers to drawings by listing the last set of digits and the letter preceding them. In the example below, the drawing would be referred to as **Drawing A-69945**. Referenced drawings are inserted at the *end of the first section which references them*.

1.2 Display Overview

Reference Drawing: Display, CH-1036H..... **Drawing A-51724**

Drawing A-51724 shows a Daktronics CH-1036H auto racing display. The CH-1036H display along with the use of the Daktronics CHTS-300 timing console will display the lap number and lap time on the display.

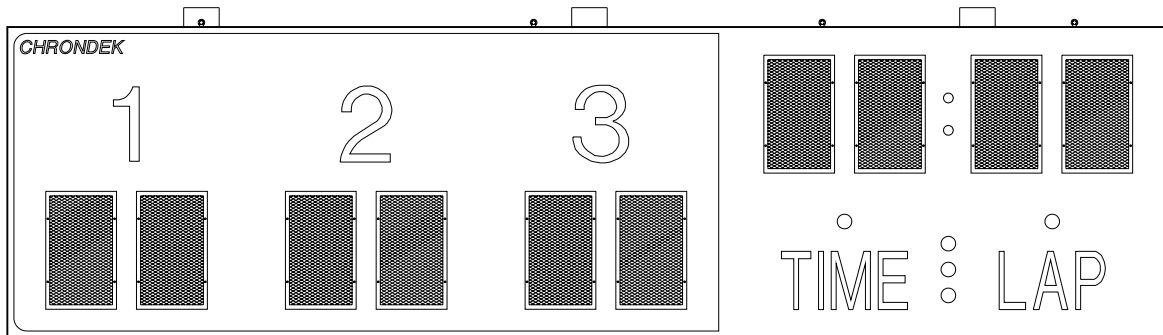

OVERALL DIMENSIONS: 96" H x 360" W x 6" D

WEIGHT: 1125 LBS

POWER REQUIREMENTS: 120/240 VAC, 40 AMPS PER LINE

MAXIMUM POWER DEMAND: 5415 WATTS WITH 25W FROSTED LAMPS.
6425 WATTS WITH 30W FROSTED, 30R20 REFLECTOR LAMPS.

DIGITS ARE 36" HIGH, 4 x 7 LAMP MATRICES, WITH 25W OR 30W FROSTED MEDIUM BASE OR 30W FROSTED, 30R20 REFLECTOR LAMPS.

DAKTRONICS, INC. BROOKINGS, SD 57006

PROJ: CHRONDEK

TITLE: DISPLAY, CH-1036H

DES. BY:

DRAWN BY: C FICKBOHM

DATE: 27 MAY 92

REVISION

APPR. BY:

SCALE: 1=55

1081-R08A-51724

REV.	DATE	DESCRIPTION	BY	APPR.

Section 2: Installation

2.1 General System

Reference Drawings: Pwr/Sig Entrance, 1 Driver Display **Drawing A-46755**
 Connector Plate, CH-836H **Drawing A-47128**
 Color Code, 25-Pin J-Box **Drawing A-47207**
 Installation Specifications..... **Drawing A-50136**
 Display Splice Mounting..... **Drawing A-51576**
 Display Mounting, CH-XX36H..... **Drawing A-51757**
 Component Locations, CH-1036H **Drawing A-51804**

Refer to **Drawing A-51728** for a general system layout.

The general procedure for installing the CH-1018H display is as follows:

1. Select beam and footing recommendations from the table below.
2. Dig the footing holes and install beams and footings.
3. Route power and signal cables to the display and control locations.
4. Mount the displays to the beams as described in **Section 2.3** and **Drawings A-50136, A-51756** and **A-51757**.
5. Route power and signal wires into the displays as described in **Section 2.4** and **Drawings A-46755, A-47128, A-47207, and A-51804**.

2.2 Beam and Footing Selection

Reference Drawing: Installation Specifications, CH-1036H **Drawing A-50136**

The table below contains recommendations for W-shape beams and footings to support the display as shown in **Drawing A-50136**. The first column is wind velocity in miles per hour. The distance in the second column is from the ground to the bottom of the display. The choice from these columns depends upon the display location.

The beams listed below are beams which provide maximum wind load strength for the weight and cost of the beams.

Wind Speed	Height (ft)	Beam Section	Footing Depth x Dia.
70 mph	10	W8 x 15	4 ¾ ft x 3 ft
	15	W6 x 20	5 ½ ft x 3 ft
80 mph	10	W8 x 15	5 ½ ft x 3 ft
	15	W8 x 20	6 ¾ ft x 3 ft
90 mph	10	W8 x 17	6 ¼ ft x 3 ft
	15	W8 x 24	7 ft x 3 ft

The calculations for footing diameters and depths are based on the assumption that footings are in undisturbed soils, *not fill soils*. Lateral bearing capacity of 300 psf per foot of depth in natural grade was used to derive these figures.

The footing recommendations are based on the allowable soil bearing pressure of 3000 psf vertically and 300 psf/ft of depth horizontally. However, these recommendations *are suggestions only* and soil bearing pressure at the site must be determined by a sample test prior to specifying actual footings. Be sure that the installation complies with local codes and is suitable for the particular soil and wind conditions. *Daktronics assumes no responsibility for structures installed by others.* Daktronics recommends that W-sections of grade 35 steel be used for beams, and that 28-day (strength 3000 psi) concrete be used for footings.

A note about beam nomenclature: For a typical beam, W6 x 12 for example "W" stands for "Wide-Flange Beam". The first number (6) is the approximate front to rear dimension of the beam in inches. The second number (12) is the weight per foot in pounds. This numbering is a standard in the steel industry. Widths are from 6.00 to 8.00 inches in the chart above.

2.3 Display Mounting

Reference Drawings: Display Splice Mounting **Drawing A-51576**
Display Mounting, CH-XX36H..... **Drawing A-51757**

Drawing A-51757 shows the typical mounting for the display.

Note: The bolts that secure the display sections do not go through the beams, but run along both sides of the beam to clamp the display to the beams.

A mounting kit consisting of 9 mounting angles 3 splice channels and 1/2" hardware are provided to mount the display.

1. Position the display against the mounting beams and secure the bottom of the display to both beams as shown in **Drawing A-51757**.
2. Next, secure the top of the display. Once mounting angles are attached, the display may be slid up or down to the desired height.
3. Once positioned as desired, tighten all bolts.
4. Position the right display section next to the left display section and secure to the beam the same way as the left display section was mounted.
5. Secure remaining mounting angles.
6. Attach the 3 splice channels at the top, bottom and center of the display where the two display sections meet to secure the two sections together as shown in **Drawing A-51756**.

2.4 Electrical Installation

2.4.1 Control Signal Cable

Reference Drawings: Pwr/Sig Entrance, 1 Driver Display.. **Drawing A-46755**
Color Code, 25-Pin J-Box **Drawing A-47207**
Component Locations,CH-1036H ... **Drawing A-51804**

For the display, two conductors of 24 AWG are needed. For distances up to 600 ft. or 22 AWG, up to 1000 ft. are required. Daktronics has 24 AWG direct burial cable, Daktronics part no. W-1105 with 6 conductors, and 22 AWG cable that must be pulled through the conduit before burial, Daktronics part no. W-1077 with 2 conductors.

At the control location, mount the signal J-box to a convenient location. Route the cables and connect to the wires leading from the connector in the cover according to the table below and **Drawing A-47207**.

At the display, open the bottom hinged panel covering the entrance enclosure as shown on **Drawing A-51804**. Remove the cover from the entrance enclosure. Refer to **Drawing A-46755** for an illustration of the components inside the entrance enclosure. Connect the signal wires to TB31 as indicated in the table below.

Control End			Display End
J-box Terminal No.	Wire Color	Output No.	TB31 Terminal No.
14	Red/Wht	1*	1 (+)
15	Grn/Wht		2 (-)

*Auxiliary display(s) require(s) a different output no.(s). Consult your CHTS-300 console manual.

2.4.2 Power Wiring

Reference Drawing: Pwr/Sig Entrance, 1 Driver Display.... **Drawing A-46755**

The CH-1036H display requires a 120/240 VAC, 40 amp circuit per line. When equipped with 25W lamps, the maximum current draw is 45 amps. When equipped with 30W, 30R20 reflector lamps, the maximum current draw is 54 amps.

Route power wires into the display and connect to TB41 in the entrance enclosure, as shown in **Drawing A-46755**.

Connect the ground wire to E41 and to a ground rod near the display, according to local codes.

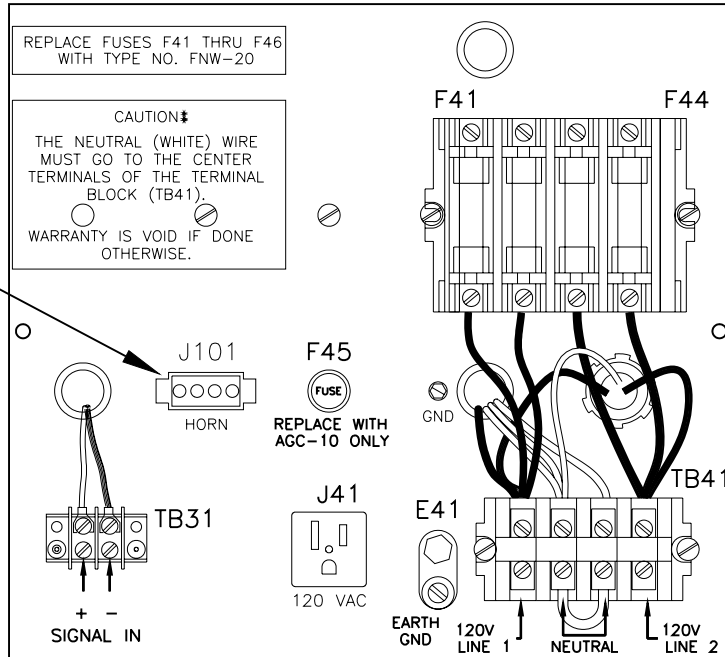

FRONT VIEW

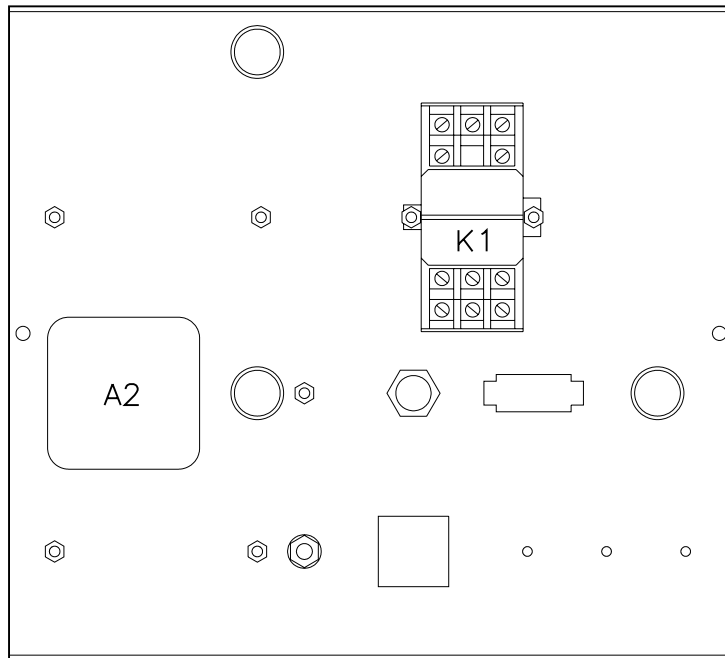

REAR VIEW

3	4 MAR 93	REMOVED LIST OF MODEL NO.'S	C FICK		DAKTRONICS, INC. BROOKINGS, SD 57006	
2	27 MAY 92	ADDED CH-1036H TO LIST OF MODEL NO.'S.	C FICK		PROJ: CHRONDEK DISPLAYS	
1	25 APR 91	CHANGED DWG TITLE AND ADDED MODEL NO.'S.	CF		TITLE: PWR/SIG ENTRANCE, 1 DRIVER DISPLAY	
REV.	DATE	DESCRIPTION	BY	APPR.	DES. BY:	DRAWN BY: CF DATE: 27 MAR 91
					REVISION	APPR. BY:
					SCALE: 1=3	1081-R04A-46755

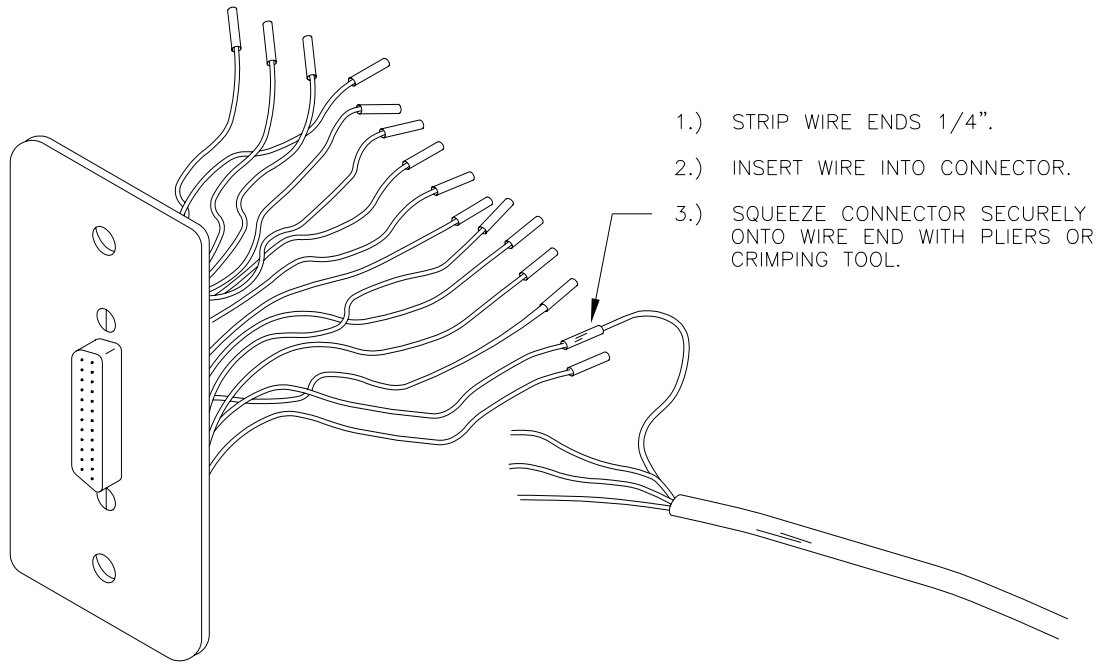

- 1.) STRIP WIRE ENDS 1/4".
- 2.) INSERT WIRE INTO CONNECTOR.
- 3.) SQUEEZE CONNECTOR SECURELY ONTO WIRE END WITH PLIERS OR CRIMPING TOOL.

PIN NO.	WIRE COLOR	FUNCTION	
1	BLACK	PHOTO 1-N	PHOTOCELL POWER INPUTS
2	WHITE	PWR 1-P	
3	RED	GND 1-N	
4	GREEN	PHOTO 2-N	
5	ORANGE	PWR 2-P	
6	BLUE	GND 2-N	
7	WHITE/BLACK	PHOTO 3-N	
8	RED/BLACK	PWR 3-P	
9	GREEN/BLACK	GND 3-N	
10	ORANGE/BLACK	PHOTO 4-N	
11	BLUE/BLACK	PWR 4-P	
12	BLACK/WHITE	GND 4-N	
14	RED/WHITE	1 SIG-P	SCOREBOARD SIGNAL OUTPUTS
15	GREEN/WHITE	1 SIG-N	
16	BLUE/WHITE	2 SIG-P	
17	BLACK/RED	2 SIG-N	
18	WHITE/RED	3 SIG-P	
19	ORANGE/RED	3 SIG-N	
22	BLUE/RED	4 SIG-P	
23	RED/GREEN	4 SIG-N	
13	ORANGE/GREEN	NOT USED	THESE PINS TYPICALLY NOT USED BY CHTS TIMER
20	BLK/WHT/RED	NOT USED	
21	WHT/BLK/RED	NOT USED	
24	RED/BLK/WHT	12 VAC	
25	GRN/BLK/WHT	12 VAC	

DAKTRONICS, INC. BROOKINGS, SD 57006																										
2	10MAR97	ADDED WIRES TO PINS 13,20,21,24,25	EB																							
1	4 JUN 92	CHANGED "SIGNAL INPUTS" TO "SIGNAL OUTPUTS"	C FICK																							
REV.	DATE	DESCRIPTION	BY	APPR.																						
<table border="1" style="width: 100%;"> <tr> <td colspan="5" style="text-align: center;">PROJ: CHRONDEK</td> </tr> <tr> <td colspan="5" style="text-align: center;">TITLE: COLOR CODE, 25-PIN J-BOX</td> </tr> <tr> <td colspan="2">DES. BY: CF</td> <td colspan="2">DRAWN BY: CF</td> <td>DATE: 1 MAY 91</td> </tr> <tr> <td>REVISION</td> <td>APPR. BY: AVB</td> <td colspan="3" rowspan="2" style="text-align: center; vertical-align: middle;">1067-R10A-47207</td> </tr> <tr> <td></td> <td>SCALE: 1=2</td> </tr> </table>					PROJ: CHRONDEK					TITLE: COLOR CODE, 25-PIN J-BOX					DES. BY: CF		DRAWN BY: CF		DATE: 1 MAY 91	REVISION	APPR. BY: AVB	1067-R10A-47207				SCALE: 1=2
PROJ: CHRONDEK																										
TITLE: COLOR CODE, 25-PIN J-BOX																										
DES. BY: CF		DRAWN BY: CF		DATE: 1 MAY 91																						
REVISION	APPR. BY: AVB	1067-R10A-47207																								
	SCALE: 1=2																									

9-PIN JACK
(TYP)

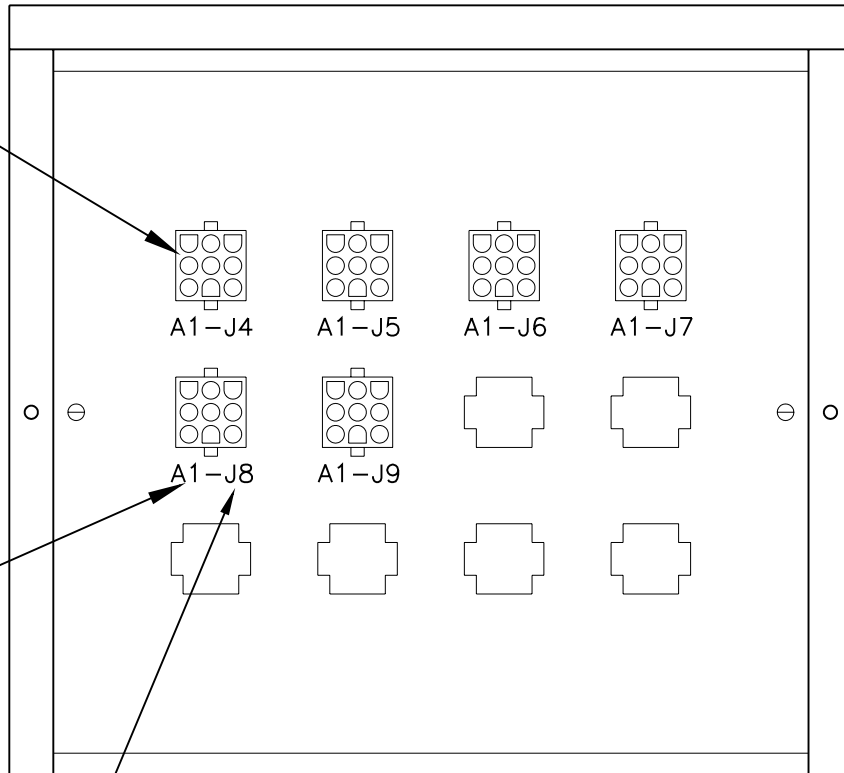

DRIVER NO.

DRIVER PLUG/DIGIT NO.
THAT PLUGS INTO THIS
9-PIN JACK.

FRONT VIEW

TYPICAL FOR MODELS:

CH-1036H
CH-1336H

DAKTRONICS, INC. BROOKINGS, SD 57006

2	18 MAY 93	ADDED MODEL CH-1036H	C FICK	
1	20 JAN 91	ADDED CH-1336H NOTE	CFICK	
REV.	DATE	DESCRIPTION	BY	APPR.

PROJ: CHRONDEK DISPLAYS	
TITLE: CONNECTOR PLATE, CH-836H	
DES. BY: CF	DRAWN BY: CF
DATE: 25 APR 91	
REVISION	APPR. BY: AVB
SCALE: 1=3	1081-R04A-47128

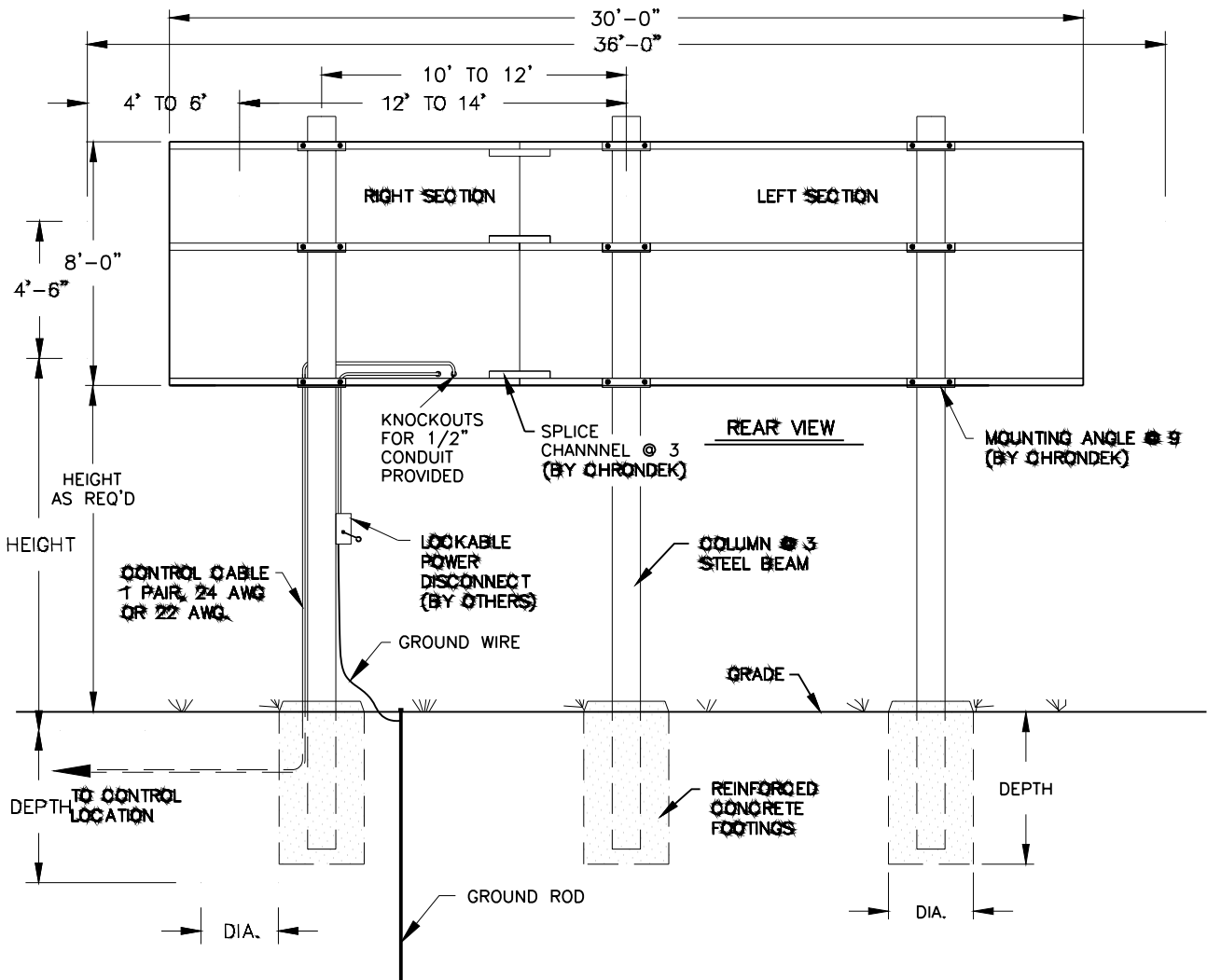

SCOREBOARD MUST BE CONNECTED TO A GROUND ROD AT SCOREBOARD LOCATION

DAKTRONICS, INC. BROOKINGS, SD 57006

PROJ: CHRONDEK

TITLE: INSTALLATION SPECIFICATIONS, CH-1036H

DES. BY:

DRAWN BY: C FICKBOHM

DATE: 29 MAY 92

REVISION

APPR. BY:

SCALE: 1=65

1081-R10A-50136

REV.	DATE	DESCRIPTION	BY	APPR.

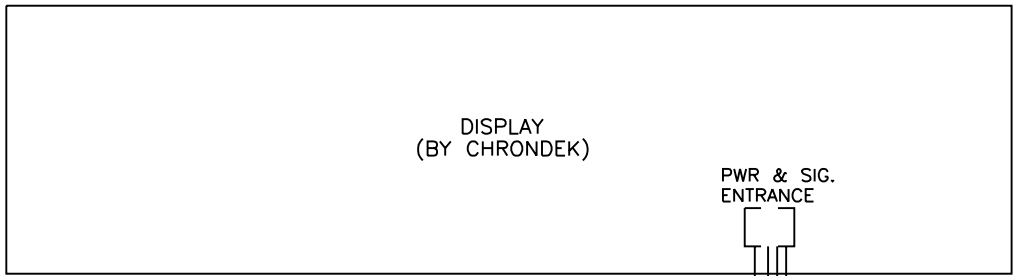

LOCKABLE DISCONNECT SWITCH, (BY OTHERS)

120/230 VAC, 40 AMPS PER LINE

EARTH GND

DISPLAY LOCATION

CONTROL SIGNAL CABLE,
1 PAIR, 24 AWG OR 22 AWG.
24 AWG UP TO 600 FT.
22 AWG UP TO 1000 FT.
IN CONDUIT BY OTHERS OR
DIRECT BURIAL.



SIGNAL BOX

SIGNAL CABLE

CONTROL LOCATION

120 VAC

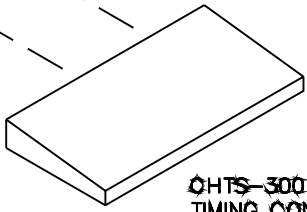
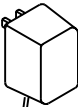

CHTS-300
TIMING CONSOLE

DAKTRONICS, INC. BROOKINGS, SD 57006	
PROJ: CHRONDEK DISPLAYS	
TITLE: SYSTEM LAYOUT, CH-1036H	
DES. BY:	DRAWN BY: C FICKBOHM DATE: 27 MAY 92
REVISION	APPR. BY:
	SCALE: 1=1
1081-R04A-51728	

REV.	DATE	DESCRIPTION	BY	APPR.

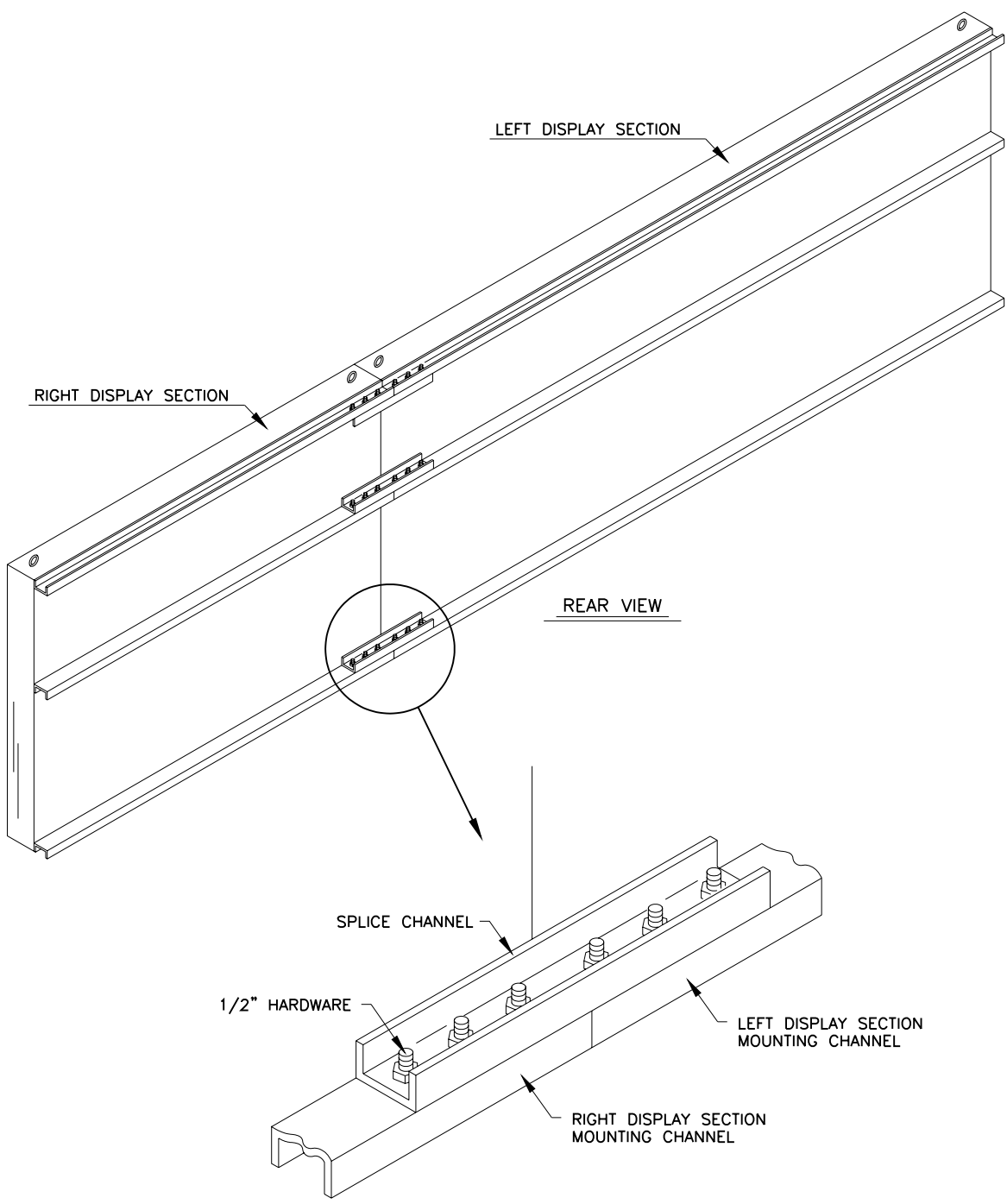

MOUNTING TYPICAL FOR MODELS:
 CH-1036H
 CH-1336H

DAKTRONICS, INC. BROOKINGS, SD 57006	
PROJ: CHRONDEK	
TITLE: DISPLAY SPLICE MTG DETAIL, CH-XX36H	
DES. BY:	DRAWN BY: C FICKBOHM DATE: 29 MAY 92
REVISION	APPR. BY:
	SCALE: NONE

1081-R08A-51756

REV.	DATE	DESCRIPTION	BY	APPR.

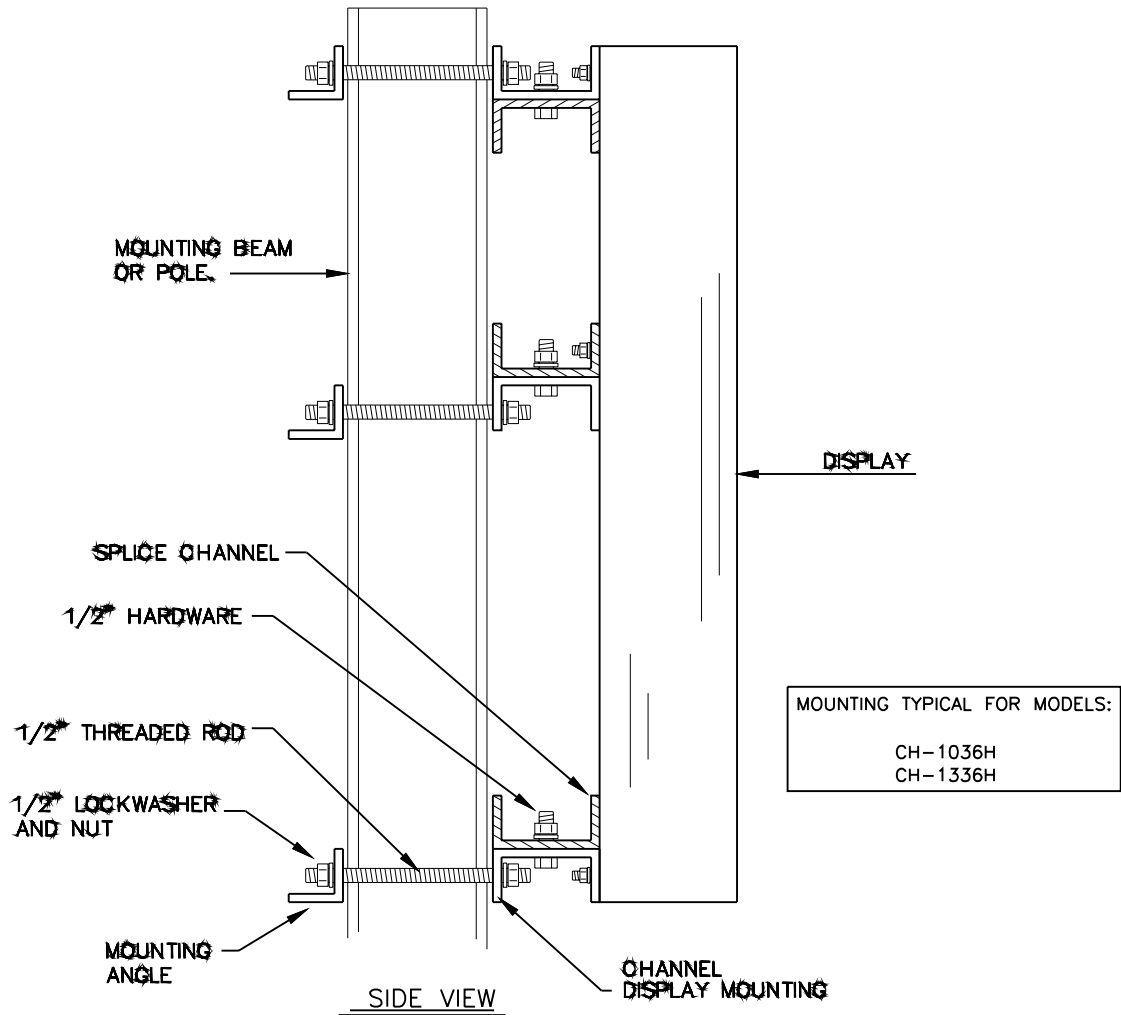

MOUNTING INSTRUCTIONS:

- 1.) LOCATE WHERE THE CENTER OF THE BEAMS WILL BE ON THE BACK OF EACH DISPLAY SECTION.
- 2.) DRILL $9/16$ " HOLES IN THE MTO CHANNELS ON THE BACK OF EACH DISPLAY SECTION AT A DISTANCE OF ± 3.50 " TO 4.50 " FROM CENTER OF EACH BEAM.
- 3.) LIFT THE LEFT DISPLAY SECTION IN PLACE FIRST.
- 4.) ATTACH MOUNTING ANGLES AND $1/2$ " THREADED RODS AS SHOWN ABOVE.
- 5.) DISPLAY CAN BE SLID UP OR DOWN TO THE HEIGHT REQUIRED.
- 6.) TIGHTEN ALL MOUNTING HARDWARE SECURELY.
- 7.) LIFT THE RIGHT DISPLAY SECTION IN PLACE NEXT TO THE LEFT DISPLAY SECTION AND ATTACH MOUNTING ANGLES AND $1/2$ " THREADED RODS AS SHOWN ABOVE.
- 8.) ATTACH (3) SPLICE CHANNELS AT TOP, BOTTOM AND MIDDLE OF DISPLAY TO MOUNTING CHANNELS ON BACK OF DISPLAY.
- 9.) TIGHTEN ALL MOUNTING HARDWARE SECURELY.

DAKTRONICS, INC. BROOKINGS, SD 57006			
PROJ: CHRONDEK DISPLAYS			
TITLE: DISPLAY MOUNTING, CH-XX36H			
DES. BY:		DRAWN BY: C FICKBOHM	
DATE: 29 MAY 92			
REVISION	APPR. BY:	1081-R08A-51757	
	SCALE: 1=1		

REV.	DATE	DESCRIPTION	BY	APPR.

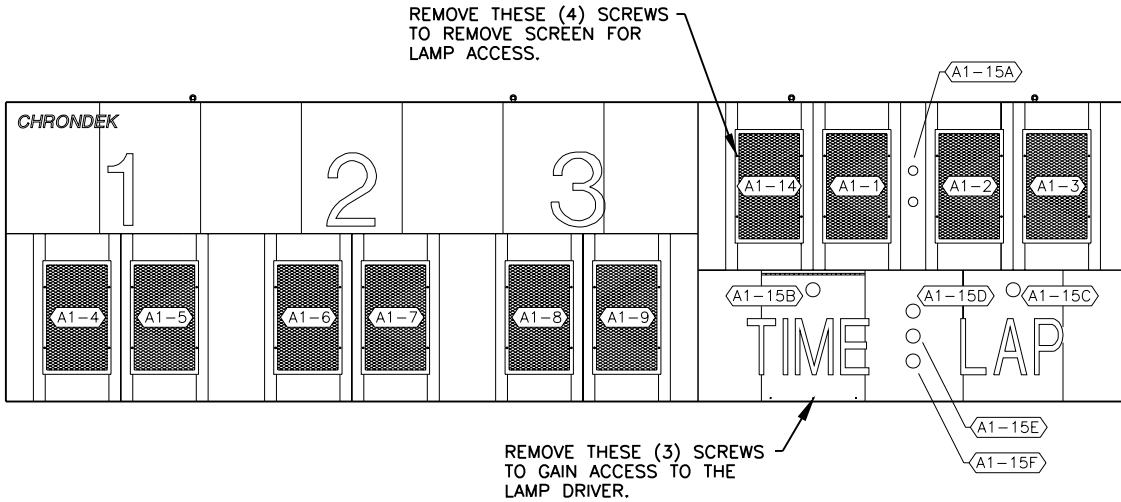

LAMP DRIVER NO. → **A1-8** = LAMP DRIVER CONNECTOR NO. WIRED TO THAT DIGIT.
 DRIVER OUTPUT CONNECTOR NO. →

LAMP DRIVER NO. → **A1-15B** = LAMP DRIVER CONNECTOR AND PIN NO.
 DRIVER OUTPUT CONNECTOR NO. AND SEGMENT NO. →

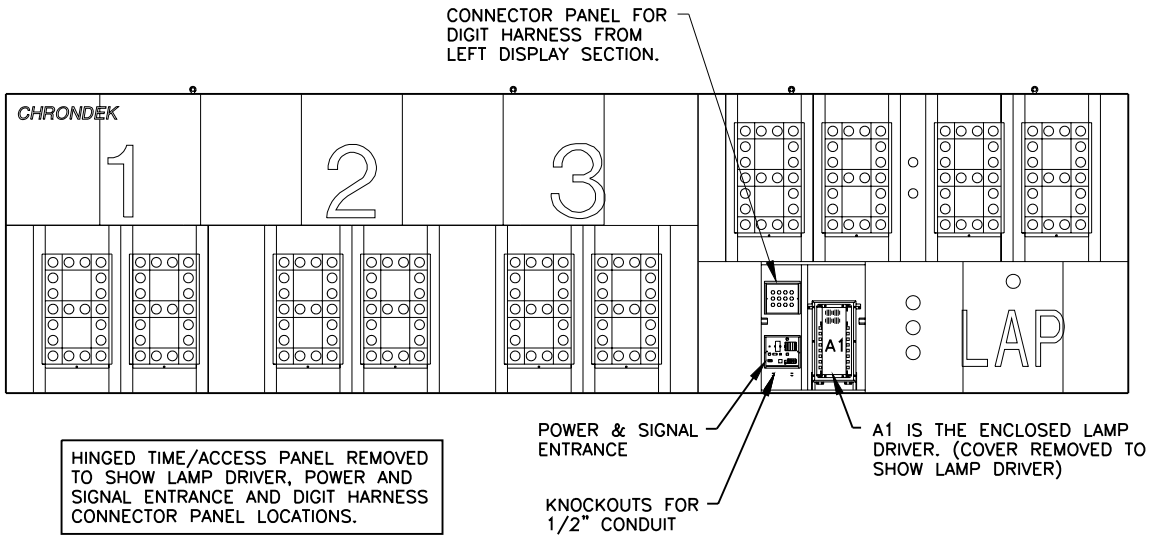

DAKTRONICS, INC. BROOKINGS, SD 57006			
PROJ: CHRONDEK			
TITLE: COMPONENT LOCATIONS, CH-1036H			
DES. BY:	DRAWN BY: C FICKBOHM	DATE: 3 JUN 92	
REVISION	APPR. BY:	1081-R08A-51804	
	SCALE: 1=55		

REV.	DATE	DESCRIPTION	BY	APPR.

Section 3: Maintenance & Troubleshooting



IMPORTANT NOTES:

1. Disconnect power before any repair or maintenance work is done on the display!
2. Any access to internal display electronics must be made by qualified service personnel.
3. Disconnect power when the display is not in use.

3.1 Lamp Replacement

Reference Drawing: Digit Service **Drawing A-27674**

The primary service required by the CH-1036H display is to replace burned-out lamps. Refer to **Drawing A-27674** for an illustration of how to access the digit lamps for replacement. Standard replacement lamps for the digits are 120V, 25W frosted medium base and may be obtained at your local store or directly from Daktronics, part number DS-1029. Some displays may be equipped with 120V, 30W reflector type 30R20 lamps, Daktronics part number DS-1126.

Do not use lamps larger than those originally installed in the display. Using higher power lamps will likely cause fuse failures in the display and could exceed the current levels that the display's circuits can safely handle.

3.2 Lamp Driver

Reference Drawings: Lamp Driver, 16 col. w/ Fan..... **Drawing A-37070**
Component Locations **Drawing A-51804**

In the display, the task of switching lamps on and off is performed by the lamp driver. **Drawing A-51804** in **Section 2** shows the location of the lamp driver in the display. **Drawing A-37070** is an illustration of the lamp driver and the fuses located in it. The lamp driver has 21 connectors, providing power and signal inputs and outputs to digits. The functions of these connectors are as follows:

Connector Number	Function
1-16	Outputs to digits
17	Signal Input
18	Power input for outputs 1-8 (120 V)
19	Power input for driver logic and fan (120V)
20	Power input for outputs 9-16 (120V)
24	Dim option selector

In **Drawing A-51804**, the numbers on the digits refer to the lamp driver output connector wired to each digit.

3.3 Digit Segmentation

Reference Drawing: Segments, 4x7 Lamp Matrix Digit..... **Drawing A-37685**

In a digit certain lamp always go on and off together. These groupings of lamps are known as "segments". Each digit has eight segments, referred by letters A through H. **Drawing A-37685** illustrates these segments and shows which connector pin and wire color is wired to each segment.

3.4 Schematic

Reference Drawings: Schematic, 1 Driver Display **Drawing A-46754**
Pwr/Sig Entrance, 1 Driver Display **Drawing A-46755**
Component Locations **Drawing A-51804**

The schematic diagram in **Drawing A-46754** shows the power and signal inputs into the display and to the lamp driver. The component numbers correspond to those shown in **Drawings A-46755** and **A-51804**.

3.5 Troubleshooting

Observed Problem	Possible Cause
One lamp won't light	<ul style="list-style-type: none">• Burned-out lamp• Broken wire behind digit
Digit segment won't light	<ul style="list-style-type: none">• Broken wire• Poor contact at driver connector• Internal driver malfunction
Entire digit won't light	<ul style="list-style-type: none">• Broken wire (black)• Poor contact at connector, pin 7• Fuse blown in driver
Half the display won't light	<ul style="list-style-type: none">• Service breaker tripped• Main fuse blown• Poor contact at main power connection• P18 disconnected
Entire display won't light	<ul style="list-style-type: none">• Power disruptions• Poor signal connection• Driver logic fuse blown• Control not connected to display• P20 disconnected
Segment stays lit	<ul style="list-style-type: none">• Broken wire behind digit• Internal driver malfunction
Garbled display	<ul style="list-style-type: none">• Control malfunction• Internal driver malfunction

If a problem is observed in one digit, the cause may be isolated by swapping plugs on the driver (connect the plug from the digit into a different jack). If the same digit shows the same problem, the cause may be in the digit or the wiring. If the problem moves to another digit, then the cause is probably an internal driver problem.

Use a volt meter at driver inputs to determine if power is being supplied to the driver. An ohmmeter can be helpful in finding broken wires and bad connections. Internal electronic problems must be correct by Daktronics or an authorized service center.

3.6 Replacement Parts

Part Name or Description	Type	Part Number
Lamp Driver		0A-1033-0122
J-Box, CHTS-300 Timer		0A-1033-0056
Fuse, Lamp Driver, 10A	AGC-10	F-1006
Fuse, Driver Logic, 1/2A	AGC-1/2	F-1000
Digit Lampbank, 36" 4x7		0A-1081-0073
Digit Screen, 36" 4x7		0S-1081-0038
Socket, Med. Base		X-1046
Lamp, 25W Frosted		DS-1029
Lamp, 30W Reflector	30R20	DS-1126
Lamp, 55W Clear Flood	55PAR38	DS-1101
Lamp, 85W Amber Flood	85PAR38	DS-1184
Lamp, 85W Green Flood	85PAR38	DS-1185
Lamp, 85W Red Flood	85PAR38	DS-1186

3.7 Unit Exchange/Replacement Procedure

Daktronics unique exchange program offers our clients the quickest, most economical way of receiving product repairs. If a component fails, Daktronics will send the customer a replacement. The customer, in turn, sends the failed component to Daktronics. This not only saves money but decreases the time the display is inoperable. Daktronics offers repair and return on a timely basis; in urgent situations, every attempt is made to ship by the fastest transit method available.

1. **Packaging for Return:** Package and pad the item well to prevent damage during shipment. Electronic components, such as printed circuit boards, should either be installed in an enclosure or placed in an anti-static bag before boxing.

Please enclose your name and address along with a list of all the symptoms. Please be as specific as possible.

2. **Driver Packaging Instructions:** Drivers should be placed in a static-free enclosure for return shipping. An anti-static convoluted foam packing is available from Daktronics (part number PK-1135). The shipping box (Daktronics part number PK-1006) should be used along with the foam.
3. **Where to Send:** Contact your local representative prior to shipment to acquire a Return Material Authorization Number (RMA#). This will speed up the repair of your unit.

When returning defective items under the exchange program, please use the UPS Blue Return Tags found in the package containing the exchange unit sent from Daktronics. This will speed up the transaction and help avoid confusion when the part is returned to Daktronics. **The defective item must be returned within 15 days of receiving a replacement part.** Using the UPS Blue Return Tag immediately will eliminate the possibility of late charges being assessed against your account.

Mail: Daktronics, Inc., Customer Service

PO Box 5128
331 32nd Avenue
Brookings, SD 57006

Phone: Toll Free: 1-800-843-9879
or 1-605-697-4400

Customer Service Fax: 1-605-697-4444

E-Mail: helpdesk@daktronics.com

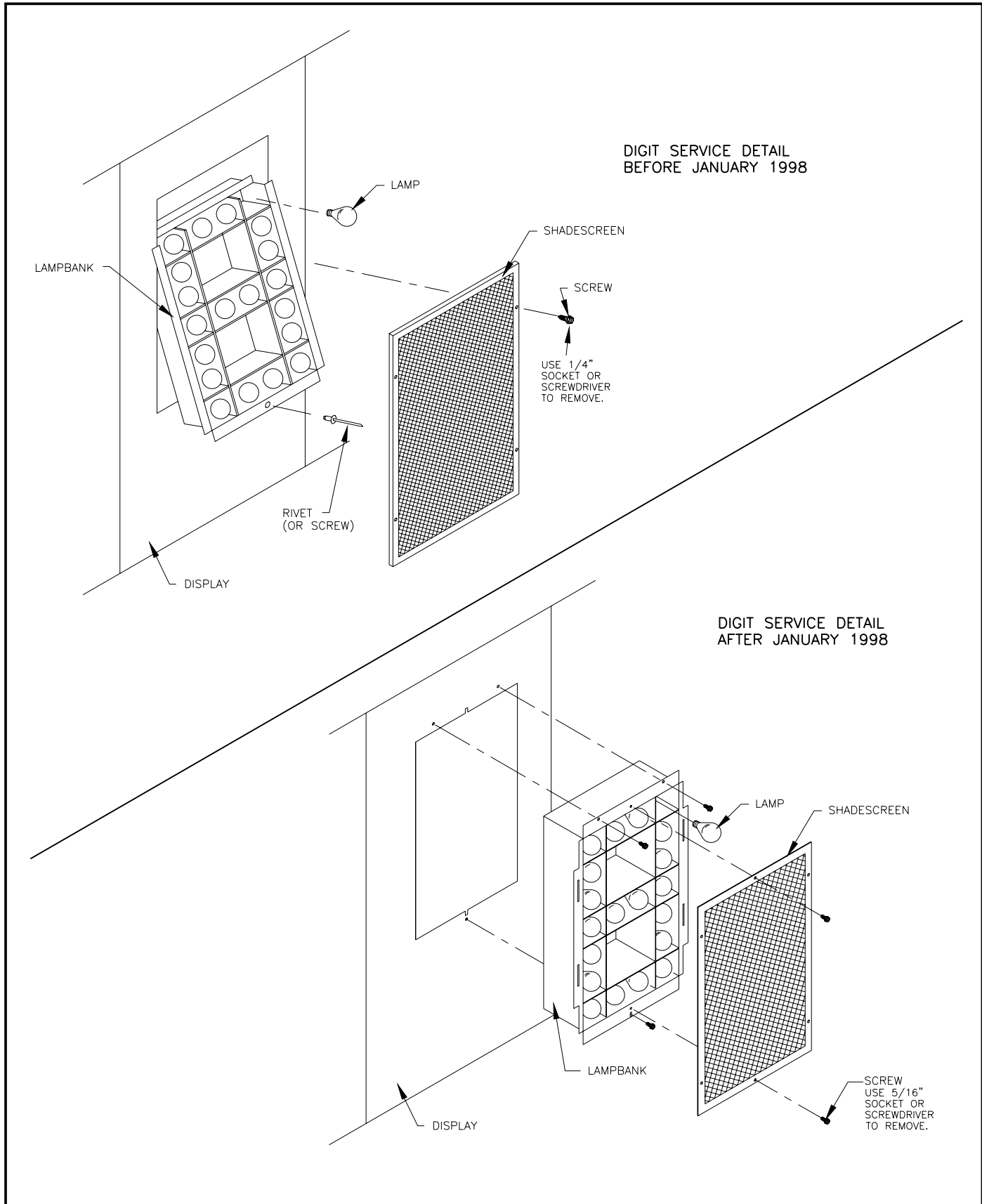

DAKTRONICS, INC. BROOKINGS, SD 57006				
PROJ: OUTDOOR SCOREBOARDS				
TITLE: DIGIT SERVICE				
DES. BY:		DRAWN BY: TERRY P.		DATE: 31 JULY 86
REVISION	APPR. BY:	1064-E10A-27674		
SCALE: 1=15				
2	10 NOV 97	ADDED DIGIT SERVICE AFTER JANUARY 1998 CHANGED SCALE FROM 1=10 TO 1=15	BDP	
1	5 MAR 91	CHANGED FROM "B" TO "A" SIZE DWG.	CF	
REV.	DATE	DESCRIPTION	BY	APPR.

DRIVER FRONT VIEW WITH COVER

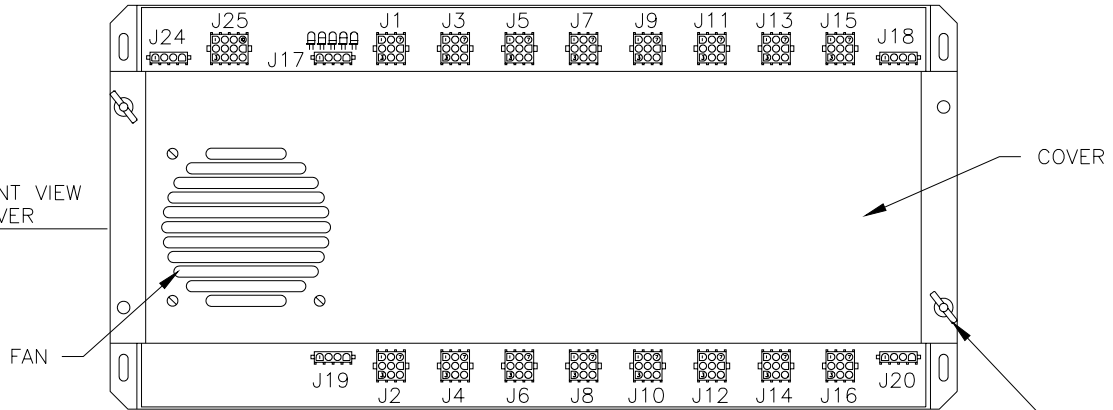

REMOVE TWO WING NUTS TO REMOVE COVER AND GAIN ACCESS TO FUSES.

J24

PIN	FUNCTION	PIN	FUNCTION
1	NETWORK+	7	ADDR 3 -
2	NETWORK-	8	NTW GND -
3	NTWREF-P	9	NTW GND -
4	ADDR 0 -	10	FAN SW HOT
5	ADDR 1 -	11	FAN HOT
6	ADDR 2 -	12	NEUT

J17

PIN	FUNCTION
1	SIGNAL +
2	SIGNAL -
3	N.C.
4	N.C.

J1 - J16

PIN	FUNCTION
1	SEG C
2	SEG B
3	SEG A
4	SEG F
5	SEG E
6	SEG D
7	COMMON
8	SEG H
9	SEG G

J18

PIN	FUNCTION
1	LAMP NEUT
2	LAMP NEUT
3	LAMP HOT 1, 3, 5, 7
4	LAMP HOT 2, 4, 6, 8

DRIVER FRONT VIEW WITH COVER REMOVED

J24

PIN	FUNCTION
1	-5V
2	DIM SEL 1
3	-5V
4	DIM SEL 2

J23

PIN	FUNCTION
1	FAN SW HOT
2	N.C.
3	FAN HOT
4	NEUT

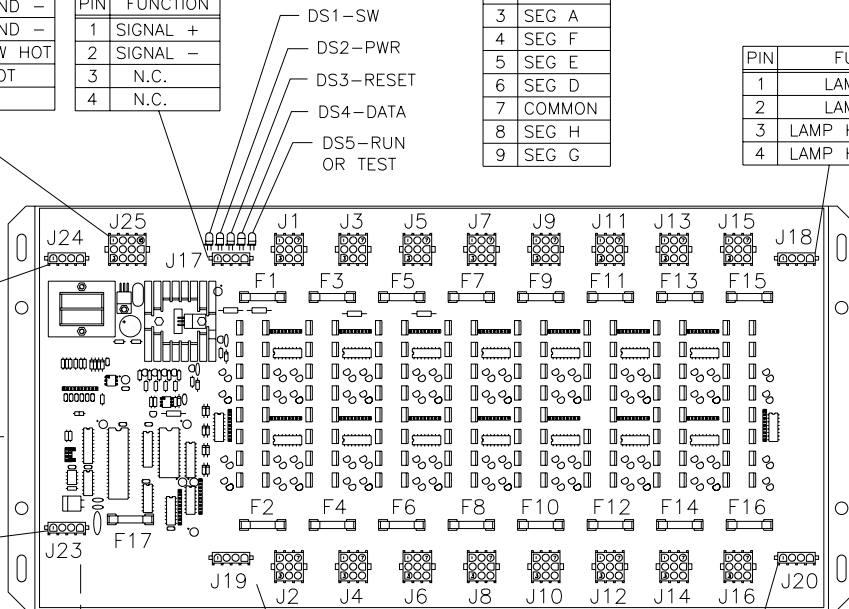

J19

PIN	FUNCTION
1	NEUTRAL
2	NEUTRAL
3	120V HOT
4	120V HOT

J20

PIN	FUNCTION
1	LAMP NEUT
2	LAMP NEUT
3	LAMP HOT 9,11,13,15
4	LAMP HOT 10,12,14,16

PLUG FROM FAN IN COVER CONNECTS TO J23

F1 THRU F16 ARE TYPE AGC-10, DAKTRONICS PART NUMBER F-1006. F17 IS TYPE AGC-1/2, DAKTRONICS PART NUMBER F-1000

REV.	DATE	DESCRIPTION	BY	APPR.
2	29 APR 97	ADDED TABLES OF PINS AND FUNCTIONS.	AVB	AVB
1	5 MAR 91	CHANGED FROM "B" TO "A" SIZE DWG.	CF	

DAKTRONICS, INC. BROOKINGS, SD 57006				
PROJ:	MULTIPLEX CONTROLLERS			
TITLE:	LAMP DRIVER, 16 COL., W/FAN			
DES. BY:	JLH	DRAWN BY:	JLH	DATE: 20 FEB 89
REVISION	APPR. BY:	1033-R04A-37070		
	SCALE: 1=5			

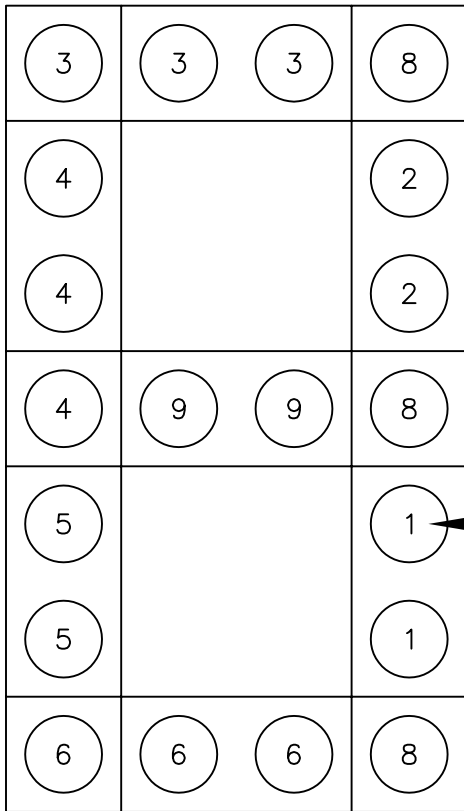

4 x 7 LAMP MATRIX DIGIT

CONNECTOR PIN NUMBER WIRED TO THAT SEGMENT

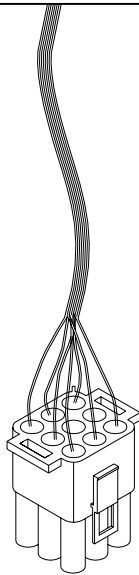

LAMP DRIVER CONNECTOR

COLOR CODE		
PIN NO.	WIRE COLOR	DRIVER SEGMENT
1	ORANGE	C
2	RED	B
3	BROWN	A
4	BLUE	F
5	GRN OR PNK	E
6	YEL OR TAN	D
7	BLACK	COMMON
8	GRAY	H
9	VIOLET	G

DAKTRONICS, INC. BROOKINGS, SD 57006		
PROJ: OUTDOOR SCOREBOARDS		
TITLE: SEGMENTS, 4 x 7 LAMP MATRIX DIGIT		
DES. BY:	DRAWN BY: AVB	DATE: 18 APR 89
REVISION	APPR. BY:	1064-R04A-37685
	SCALE: 1=1	

1	5 MAR 91	CHANGED FROM "B" TO "A" SIZE DWG.	CF	
REV.	DATE	DESCRIPTION	BY	APPR.

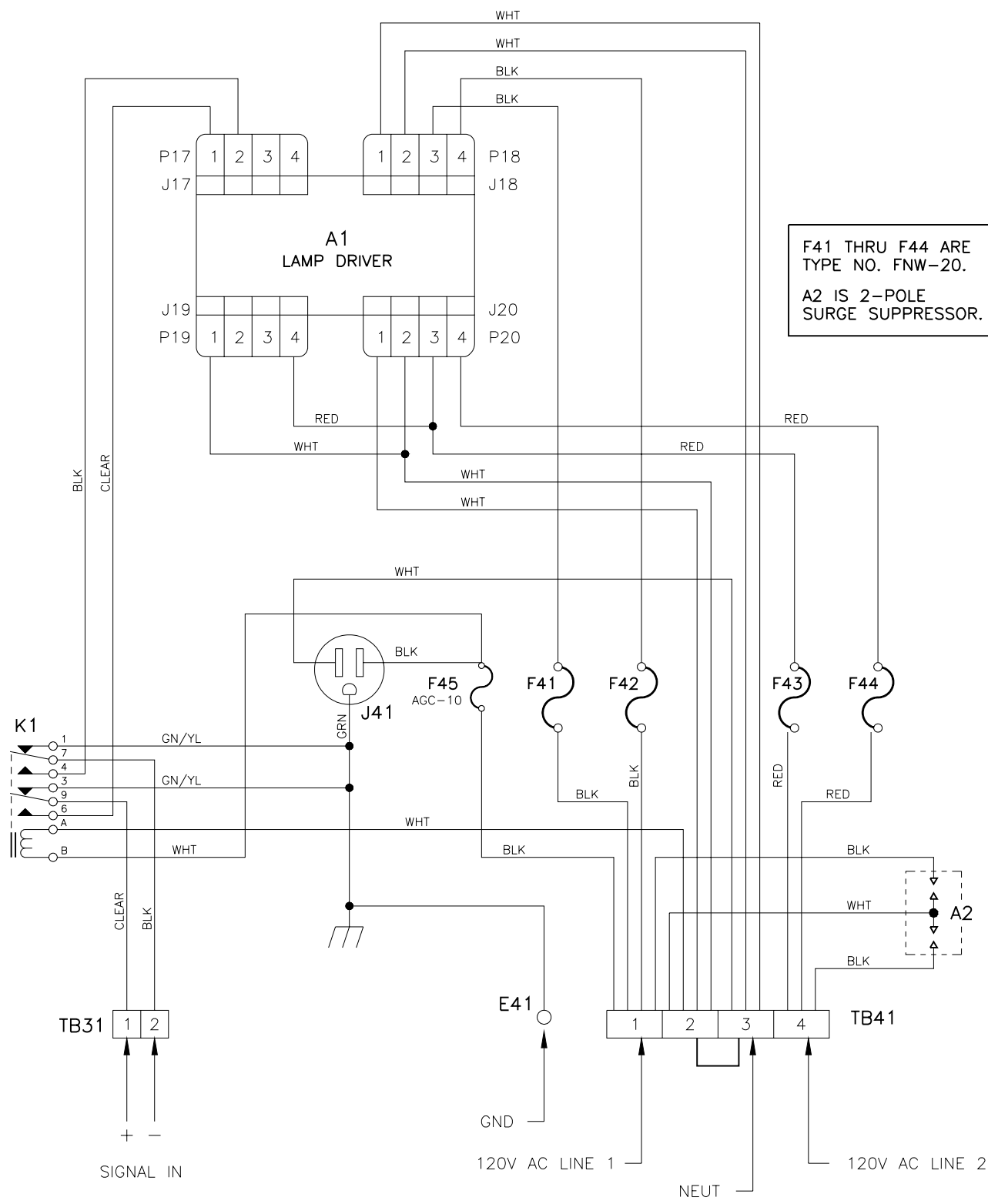

F41 THRU F44 ARE
TYPE NO. FNW-20.
A2 IS 2-POLE
SURGE SUPPRESSOR.

3	4 MAR 93	REMOVED MODEL NO.'S LIST.	C FICK	DAKTRONICS, INC. BROOKINGS, SD 57006	
2	26 MAY 92	ADDED MODEL CH-1036H TO LIST OF MODEL NO.'S.	C FICK	PROJ: CHRONDEK DISPLAYS	
1	25 APR 91	CHANGED DWG TITLE AND ADDED MODEL NO.'S	CF	TITLE: SCHEMATIC, 1 DRIVER DISPLAY	
REV.	DATE	DESCRIPTION	BY	APPR.	DES. BY: DRAWN BY: CF DATE: 27 MAR 91
					REVISION APPR. BY: SCALE: NONE 1081-R03A-46754